

Installation Manual

Installation and Appliance Setup

INSTALLER: Leave this manual with party responsible for use and operation.

OWNER: Retain this manual for future reference.

NOTICE: DO NOT discard this manual!

QUADRA-FIRE®

Models:

GARN-MBK-IPI

GARN-D-PMH-IPI

GARN-D-MBK-IPI

GARN-D-CSB-IPI

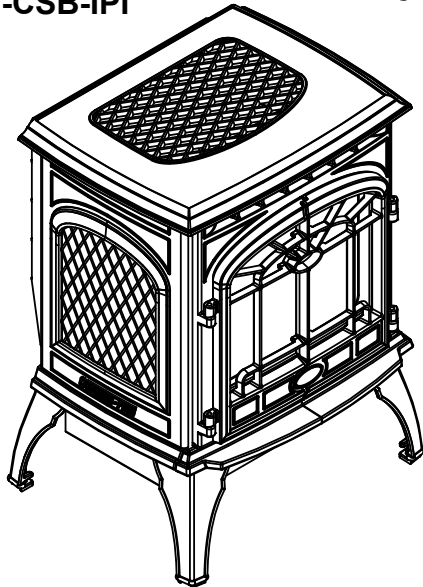

This appliance may be installed as an OEM installation in manufactured home (USA only) or mobile home and must be installed in accordance with the manufacturer's instructions and the manufactured home construction and safety standard, *Title 24 CFR, Part 3280* or *Standard for Installation in Mobile Homes, CAN/CSA Z240MH*, in Canada.

This appliance is only for use with the type(s) of gas indicated on the rating plate.

WARNING: If the information in these instructions is not followed exactly, a fire or explosion may result causing property damage, personal injury, or death.

- **DO NOT** store or use gasoline or other flammable vapors and liquids in the vicinity of this or any other appliance.
- **What to do if you smell gas**
 - **DO NOT** try to light any appliance.
 - **DO NOT** touch any electrical switch. **DO NOT** use any phone in your building.
 - Immediately call your gas supplier from a neighbor's phone. Follow the gas supplier's instructions.
 - If you cannot reach your gas supplier, call the fire department.
- Installation and service must be performed by a qualified installer, service agency, or the gas supplier.

WARNING



HOT GLASS WILL CAUSE BURNS.

DO NOT TOUCH GLASS UNTIL COOLED.

NEVER ALLOW CHILDREN TO TOUCH GLASS.

In the Commonwealth of Massachusetts installation must be performed by a licensed plumber or gas fitter.

See Table of Contents for location of additional Commonwealth of Massachusetts requirements.

▲ Safety Alert Key:

- **DANGER!** Indicates a hazardous situation which, if not avoided will result in death or serious injury.
- **WARNING!** Indicates a hazardous situation which, if not avoided could result in death or serious injury.
- **CAUTION!** Indicates a hazardous situation which, if not avoided, could result in minor or moderate injury.
- **NOTICE:** Used to address practices not related to personal injury.

Table of Contents

Installation Standard Work Checklist	3
--	---

1 Product Specific and Important Safety Information

A. Appliance Certification	4
B. Glass Specifications	4
C. BTU Specifications	4
D. High Altitude Installations	4
E. Non-Combustible Materials Specification	4
F. Combustible Materials Specification	4
G. Electrical Codes	4
H. Requirements for the Commonwealth of Massachusetts	5

2 Getting Started

A. Design and Installation Considerations	6
B. Tools and Supplies Needed	6
C. Inspect Appliance and Components	6

3 Framing and Clearances

A. Appliance Dimension Diagram	7
B. Clearances to Combustibles	8
C. Hearth Extension/Floor Protection	8

4 Termination Location and Vent Information

A. Vent Termination Minimum Clearances	9
B. Chimney Diagram	10
C. Approved Pipe	11
D. Use of Elbows	12
E. Measuring Standards	12
F. Venting Guidelines for Horizontal Runs	13
G. Vent Diagrams	13

5 Vent Clearances and Framing

A. Pipe Clearances to Combustibles	24
B. Wall Penetration Framing/Firestops	24
C. Ceiling Firestop/Floor Penetration Framing	25
D. Install Attic Insulation Shield	25

6 Appliance Preparation

A. Leveling the Appliance	26
-------------------------------------	----

7 Venting and Chimneys

A. Assemble Vent Sections	27
B. Assemble Slip Sections	28
C. Secure the Vent Sections	29
D. Disassemble Vent Sections	29
E. Vertical Termination Requirements	31
F. Horizontal Termination Requirements	33

8 Electrical Information

A. General Information	35
B. Wiring Requirements	36

9 Gas Information

A. Fuel Conversion	40
B. Gas Pressure	40
C. Gas Connection	40
D. High Altitude Installations	40
E. Air Shutter Setting	41

10 Appliance Setup

A. Remove Fixed Glass Assembly	42
B. Remove the Shipping Materials	42
C. Clean the Appliance	42
D. Install the Log Assembly	43
E. Install Fixed Glass Assembly	44

11 Reference Materials

→ A. Vent Components Diagrams	45
B. Accessories	50

→ = Contains updated information.

Installation Standard Work Checklist

ATTENTION INSTALLER: Follow this Standard Work Checklist

This standard work checklist is to be used by the installer in conjunction with, not instead of, the instructions contained in this installation manual.

Customer: _____
Lot/Address: _____

Date Installed: _____
Location of Stove: _____
Installer: _____
Dealer/Distributor Phone # _____
Serial #: _____

Model (circle one): **GARN-MBK-IPI**
GARN-D-PMH-IPI
GARN-D-MBK-IPI
GARN-D-CSB-IPI

 **WARNING! Risk of Fire or Explosion!** Failure to install appliance according to these instructions can lead to a fire or explosion.

Appliance Install

Verified combustible or non-combustible clearances to walls. (Pg. 8)	<input type="checkbox"/>	IF NO, WHY?
Stove is installed level. (Pg. 26)	<input type="checkbox"/>	_____

Venting/Chimney Section 7 (Pg 27-34)

Venting configuration complies with allowable vent requirements.	<input type="checkbox"/>	_____
Venting installed, locked and secured in place with proper clearance.	<input type="checkbox"/>	_____
Interior/Exterior firestops installed and sealed.	<input type="checkbox"/>	_____
Attic insulation shield installed.	<input type="checkbox"/>	_____
Exterior wall/Roof flashing installed and sealed.	<input type="checkbox"/>	_____
Terminations/Roof flashing installed and sealed.	<input type="checkbox"/>	_____

Electrical Section 8 (Pg 35-39)

Unswitched power (110-120 VAC) provided for the appliance.	<input type="checkbox"/>	_____
Switch wires properly installed.	<input type="checkbox"/>	_____

Gas Section 9 (Pg 40-41)

Appliance configuration matches fuel type.	<input type="checkbox"/>	_____
Was a conversion performed?	<input type="checkbox"/>	_____
Leak check performed and inlet/outlet pressure verified.	<input type="checkbox"/>	_____
Set air shutter for optimal flame appearance.	<input type="checkbox"/>	_____

Appliance Setup Section 10 (Pg 42-44)

All packaging and protective materials are from removed inside/under/on the appliance).	<input type="checkbox"/>	_____
Logs and embers installed correctly.	<input type="checkbox"/>	_____
Glass assembly installed and secured.	<input type="checkbox"/>	_____
Accessories installed properly.	<input type="checkbox"/>	_____
Manual bag and all of its contents are removed from inside/under the appliance and given to party responsible for use and operation.	<input type="checkbox"/>	_____
Started appliance and verified no gas leaks exist.	<input type="checkbox"/>	_____

Hearth & Home Technologies recommends the following:

- Photographing the installation and copying this checklist for your file.
- That this checklist remain visible at all times on the appliance until the installation is complete.

Comments: Further description of the issues, who is responsible (Installer/ Builder/ Other Trades, etc) and corrective action needed _____

Comments Communicated to party responsible _____ by _____ on _____
 (Builder / Gen. Contractor/) (Installer) (Date)

➔ = Contains updated information.

1 Product Specific and Important Safety Information

A. Appliance Certification

MODELS: GARN-MBK-IPI, GARN-D-PMH-IPI, GARN-D-MBK-IPI, GARN-D-CSB-IPI

LABORATORY: Underwriters Laboratories, Inc. (UL)

TYPE: Direct Vent Heater

STANDARD: ANSI Z21.88-2009/CSA 2.33-2009

This product is listed to ANSI standards for “Vented Gas Fireplace Heaters” and applicable sections of “Gas Burning Heating Appliances for Manufactured Homes and Recreational Vehicles”, and “Gas Fired Appliances for Use at High Altitudes”.

NOTICE: This installation must conform with local codes. In the absence of local codes you must comply with the National Fuel Gas Code, ANSI Z223.1- latest edition in the U.S.A. and the CAN/CGA B149 Installation Codes in Canada.

NOT INTENDED FOR USE AS A PRIMARY HEAT SOURCE.

This appliance is tested and approved as either supplemental room heat or as a decorative appliance. It should not be factored as primary heat in residential heating calculations.

B. Glass Specifications

This appliance is equipped with 5 mm ceramic glass. Replace glass only with 5 mm ceramic glass. Please contact your dealer for replacement glass.

C. BTU Specifications

Models (U.S. or Canada)		Maximum Input BTU/h	Minimum Input BTU/h	Orifice Size (DMS)
GARN-MBK-IPI GARN-D-PMH-IPI GARN-D-MBK-IPI GARN-D-CSB-IPI (NG)	(0-2000 FT)	14,500	10,500	49
GARN-MBK-IPI GARN-D-PMH-IPI GARN-D-MBK-IPI GARN-D-CSB-IPI (LP)	(0-2000 FT)	13,000	9750	57

D. High Altitude Installations

NOTICE: If the heating value of the gas has been reduced, these rules do not apply. Check with your local gas utility or authorities having jurisdiction.

When installing above 2000 feet elevation:

- In the USA: Reduce input rate 4% for each 1000 feet above 2000 feet.
- In CANADA: Input ratings are certified without a reduction of input rate for elevations up to 4500 feet (1370 m) above sea level. Please consult provincial and/or local authorities having jurisdiction for installations at elevations above 4500 feet (1370 m).

Check with your local gas utility to determine proper orifice size.

E. Non-Combustible Materials Specification

Material which will not ignite and burn. Such materials are those consisting entirely of steel, iron, brick, tile, concrete, slate, glass or plasters, or any combination thereof.

Materials that are reported as passing **ASTM E 136, Standard Test Method for Behavior of Materials in a Vertical Tube Furnace at 750 °C** shall be considered non-combustible materials.

F. Combustible Materials Specification

Materials made of or surfaced with wood, compressed paper, plant fibers, plastics, or other material that can ignite and burn, whether flame proofed or not, or plastered or unplastered shall be considered combustible materials.

G. Electrical Codes

NOTICE: This appliance must be electrically wired and grounded in accordance with local codes or, in the absence of local codes, with **National Electric Code ANSI/NFPA 70-latest edition or the Canadian Electric Code CSA C22.1.**

- A 110-120 VAC circuit for this product must be protected with ground-fault circuit-interrupter protection, in compliance with the applicable electrical codes, when it is installed in locations such as in bathrooms or near sinks.

Note: The following requirements reference various Massachusetts and national codes not contained in this document.

H. Requirements for the Commonwealth of Massachusetts

For all side wall horizontally vented gas fueled equipment installed in every dwelling, building or structure used in whole or in part for residential purposes, including those owned or operated by the Commonwealth and where the side wall exhaust vent termination is less than seven (7) feet above finished grade in the area of the venting, including but not limited to decks and porches, the following requirements shall be satisfied:

Installation of Carbon Monoxide Detectors

At the time of installation of the side wall horizontal vented gas fueled equipment, the installing plumber or gas fitter shall observe that a hard wired carbon monoxide detector with an alarm and battery back-up is installed on the floor level where the gas equipment is to be installed. In addition, the installing plumber or gas fitter shall observe that a battery operated or hard wired carbon monoxide detector with an alarm is installed on each additional level of the dwelling, building or structure served by the side wall horizontal vented gas fueled equipment. It shall be the responsibility of the property owner to secure the services of qualified licensed professionals for the installation of hard wired carbon monoxide detectors.

In the event that the side wall horizontally vented gas fueled equipment is installed in a crawl space or an attic, the hard wired carbon monoxide detector with alarm and battery back-up may be installed on the next adjacent floor level.

In the event that the requirements of this subdivision can not be met at the time of completion of installation, the owner shall have a period of thirty (30) days to comply with the above requirements; provided, however, that during said thirty (30) day period, a battery operated carbon monoxide detector with an alarm shall be installed.

Approved Carbon Monoxide Detectors

Each carbon monoxide detector as required in accordance with the above provisions shall comply with NFPA 720 and be ANSI/UL 2034 listed and IAS certified.

Signage

A metal or plastic identification plate shall be permanently mounted to the exterior of the building at a minimum height of eight (8) feet above grade directly in line with the exhaust vent terminal for the horizontally vented gas fueled heating appliance or equipment. The sign shall read, in print size no less than one-half (1/2) in. in size, **“GAS VENT DIRECTLY BELOW. KEEP CLEAR OF ALL OBSTRUCTIONS”**.

Inspection

The state or local gas inspector of the side wall horizontally vented gas fueled equipment shall not approve the installation unless, upon inspection, the inspector observes carbon monoxide detectors and signage installed in accordance with the provisions of 248 CMR 5.08(2)(a)1 through 4.

Exemptions

The following equipment is exempt from 248 CMR 5.08(2)(a)1 through 4:

- The equipment listed in Chapter 10 entitled “Equipment Not Required To Be Vented” in the most current edition of NFPA 54 as adopted by the Board; and
- Product Approved side wall horizontally vented gas fueled equipment installed in a room or structure separate from the dwelling, building or structure used in whole or in part for residential purposes.

MANUFACTURER REQUIREMENTS

Gas Equipment Venting System Provided

When the manufacturer of Product Approved side wall horizontally vented gas equipment provides a venting system design or venting system components with the equipment, the instructions provided by the manufacturer for installation of the equipment and the venting system shall include:

- Detailed instructions for the installation of the venting system design or the venting system components; and
- A complete parts list for the venting system design or venting system.

Gas Equipment Venting System NOT Provided

When the manufacturer of a Product Approved side wall horizontally vented gas fueled equipment does not provide the parts for venting the flue gases, but identifies “special venting systems”, the following requirements shall be satisfied by the manufacturer:

- The referenced “special venting system” instructions shall be included with the appliance or equipment installation instructions; and
- The “special venting systems” shall be Product Approved by the Board, and the instructions for that system shall include a parts list and detailed installation instructions.

A copy of all installation instructions for all Product Approved side wall horizontally vented gas fueled equipment, all venting instructions, all parts lists for venting instructions, and/or all venting design instructions shall remain with the appliance or equipment at the completion of the installation.

See Gas Connection section for additional Commonwealth of Massachusetts requirements.

2 Getting Started

A. Design and Installation Considerations

Heat & Glo direct vent gas appliances are designed to operate with all combustion air siphoned from outside of the building and all exhaust gases expelled to the outside. No additional outside air source is required.

Installation MUST comply with local, regional, state and national codes and regulations. Consult insurance carrier, local building inspector, fire officials or authorities having jurisdiction over restrictions, installation inspection and permits.

Before installing, determine the following:

- Where the appliance is to be installed.
- The vent system configuration to be used.
- Gas supply piping requirements.
- Electrical wiring requirements.
- Whether optional accessories—devices such as a fan or remote control—are desired.



Installation and service of this appliance should be performed by qualified personnel. Hearth & Home Technologies suggests NFI certified or factory trained professionals, or technicians supervised by an NFI certified professional (www.nficertified.org).

Improper installation, adjustment, alteration, service or maintenance can cause injury or property damage. For assistance or additional information, consult a qualified service technician, service agency or your dealer.

B. Tools and Supplies Needed

Before beginning the installation be sure that the following tools and building supplies are available.

- | | |
|---|-----------------------------------|
| Tape measure | Framing material |
| Pliers | Hammer |
| Phillips screwdriver | Manometer |
| Gloves | Framing square |
| Voltmeter | Electric drill and bits (1/4 in.) |
| Plumb line | Safety glasses |
| Level | Reciprocating saw |
| Flat blade screwdriver | |
| Non-corrosive leak check solution | |
| 1/2 - 3/4 in. length, #6 or #8 Self-drilling screws | |
| Caulking material (300 °F minimum continuous exposure rating) | |
| One 1/4 in. female connection (for optional fan). | |

C. Inspect Appliance and Components

- Carefully remove the appliance and components from the packaging.
- The vent system components and optional accessories may be shipped in separate packages.
- If packaged separately, the log set must be installed.
- Report to your dealer any parts damaged in shipment, particularly the condition of the glass.
- **Read all of the instructions before starting the installation. Follow these instructions carefully during the installation to ensure maximum safety and benefit.**

WARNING! Risk of Fire or Explosion! Damaged parts could impair safe operation. DO NOT install damaged, incomplete or substitute components. Keep appliance dry.

Hearth & Home Technologies disclaims any responsibility for, and the warranty will be voided by, the following actions:

- Installation and use of any damaged appliance or vent system component.
- Modification of the appliance or vent system.
- Installation other than as instructed by Hearth & Home Technologies.
- Improper positioning of the gas logs or the glass door.
- Installation and/or use of any component part not approved by Hearth & Home Technologies.

Any such action may cause a fire hazard.

WARNING! Risk of Fire, Explosion or Electric Shock! DO NOT use this appliance if any part has been under water. Call a qualified service technician to inspect the appliance and to replace any part of the control system and/or gas control which has been under water.

3 Framing and Clearances

A. Appliance Dimension Diagram

Dimensions are actual appliance dimensions. Use for reference only.

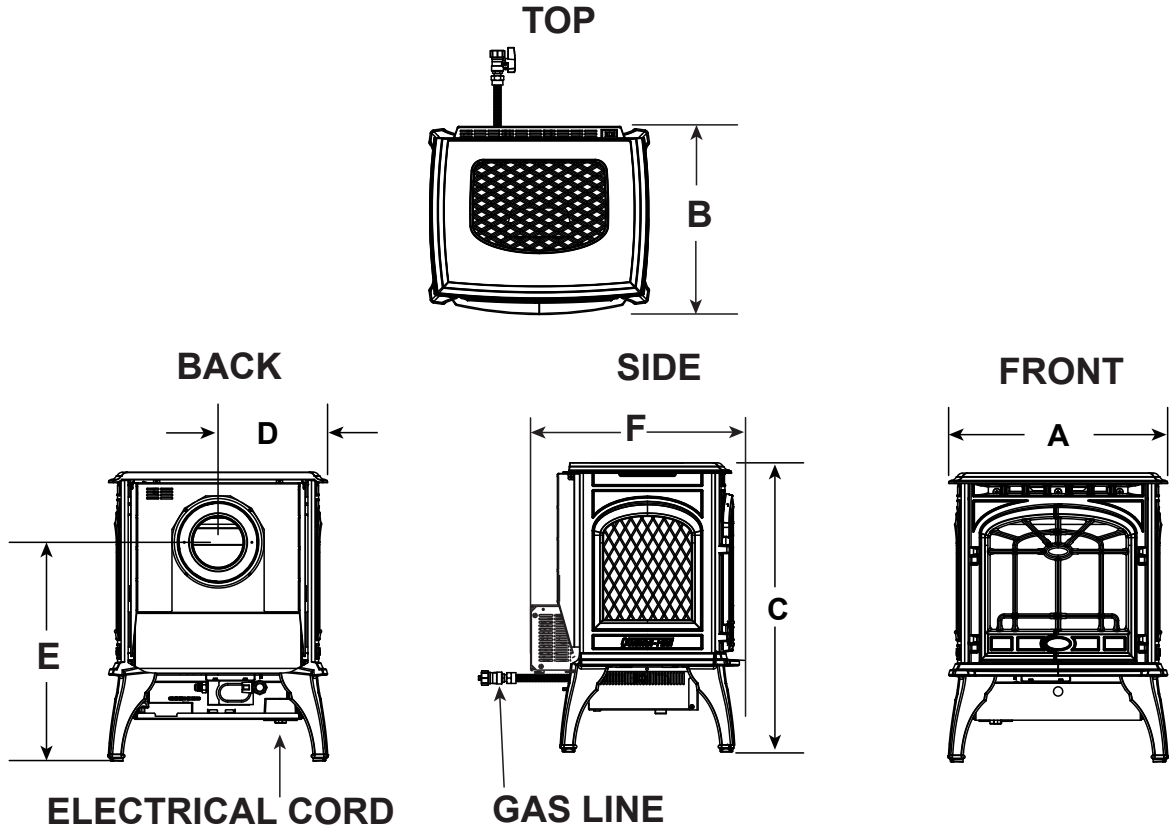

Location	Inches	Millimeter	Location	Inches	Millimeter
A	17-7/8	454	D	8-15/16	227
B	15-3/8	391	E	18-1/8	451
C	23-5/8	600	F	17-3/8	441

NOTE: Diagrams show gas appliance equipped without optional Blower, Part #GFK-160A.

Figure 3.1 Appliance Dimensions

B. Clearances to Combustibles

When selecting a location for the appliance it is important to consider the required clearances to walls. See Figure 3.2.

WARNING! Risk of Fire or Burns! Provide adequate clearance around air openings and for service access. Due to high temperatures, the appliance should be located out of traffic and away from furniture and draperies.

NOTICE: Illustrations reflect typical installations and are FOR DESIGN PURPOSES ONLY. Illustrations/diagrams are not drawn to scale. Actual installation may vary due to individual design preference.

NOTICE: Some carpet materials may be sensitive to radiant heat from the appliance causing discoloration or odor.

C. Hearth Extension/Floor Protection

CAUTION! Risk of Fire or Injury! Install appliance on a stable, level, platform or floor strong enough to support appliance without tipping.

A non-combustible hearth pad is not required. However, the floor beneath the appliance must be stable, level, and strong enough to support the appliance without a tipping hazard. It is permissible to place the appliance on carpet.

NOTE: Flooring beneath appliance may reach 90 degrees plus room ambient temperature. Check with flooring manufacturer for maximum temperature allowed on flooring surfaces.

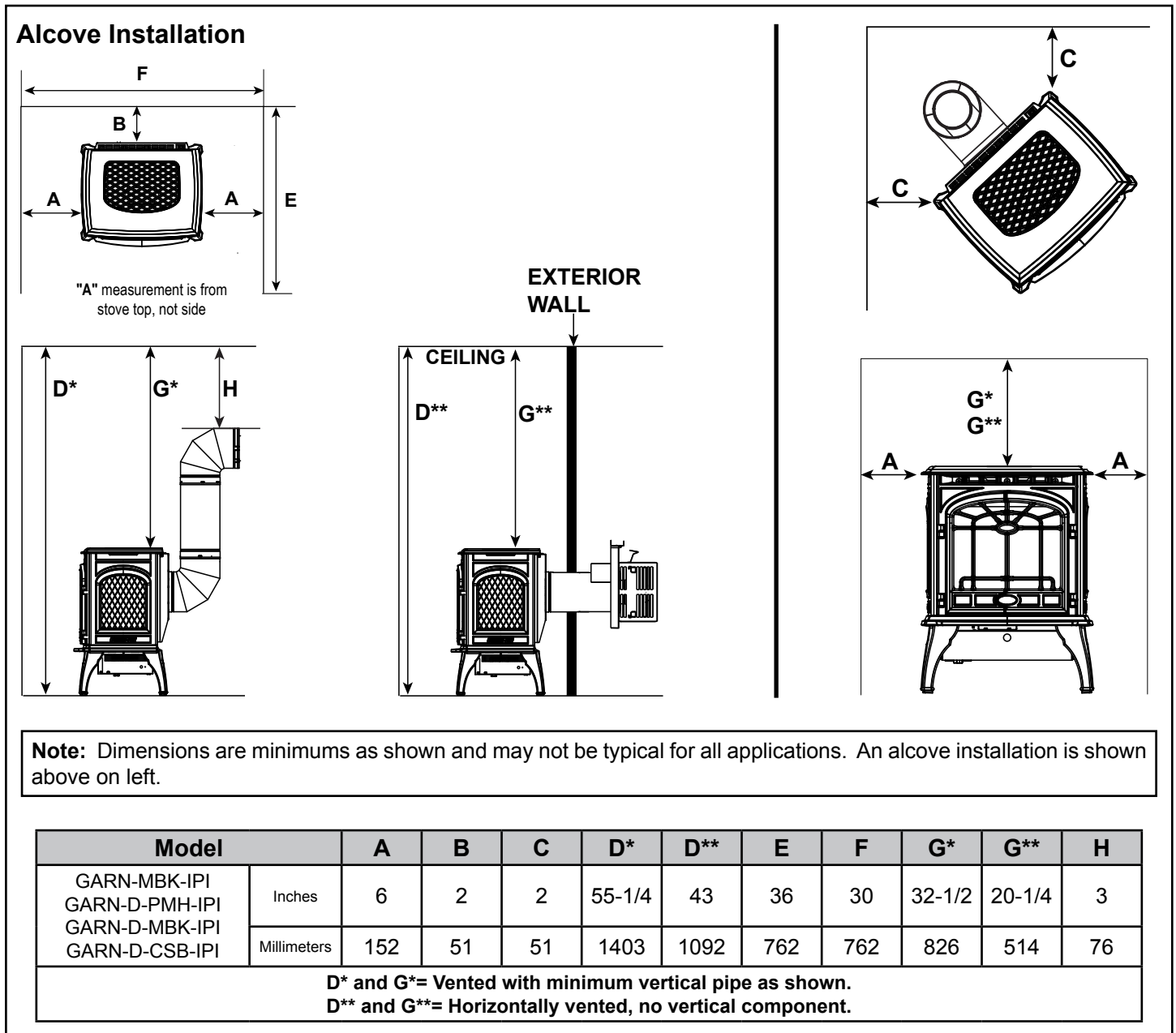



Figure 3.2 Appliance Locations

4 Termination Location and Vent Information

A. Vent Termination Minimum Clearances

WARNING



Fire Risk.

Maintain vent clearance to combustibles as specified.

- **DO NOT** pack air space with insulation or other materials.

Failure to keep insulation or other materials away from vent pipe may cause overheating and fire.

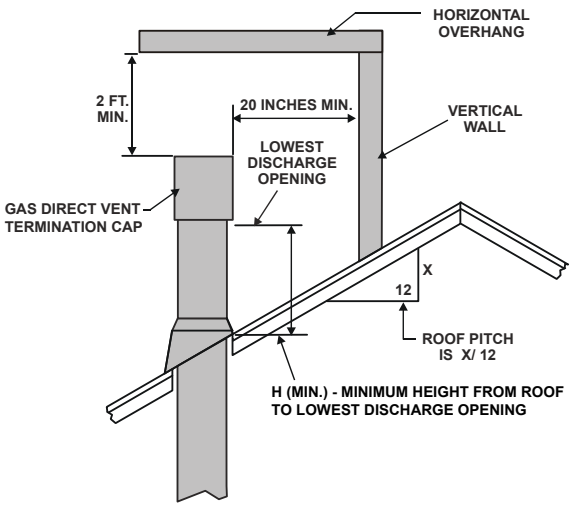

Roof Pitch	H (Min.) Ft.
Flat to 6/12.....	1.0*
Over 6/12 to 7/12.....	1.25*
Over 7/12 to 8/12.....	1.5*
Over 8/12 to 9/12.....	2.0*
Over 9/12 to 10/12.....	2.5*
Over 10/12 to 11/12.....	3.25
Over 11/12 to 12/12.....	4.0
Over 12/12 to 14/12.....	5.0
Over 14/12 to 16/12.....	6.0
Over 16/12 to 18/12.....	7.0
Over 18/12 to 20/12.....	7.5
Over 20/12 to 21/12.....	8.0

* 3 foot minimum in snow regions

Figure 4.1 Minimum Height From Roof To Lowest Discharge Opening

A	B
6 in. (minimum) up to 20 in. <i>152 mm/508 mm</i>	18 in. minimum <i>457 mm</i>
20 in. and over	0 in. minimum

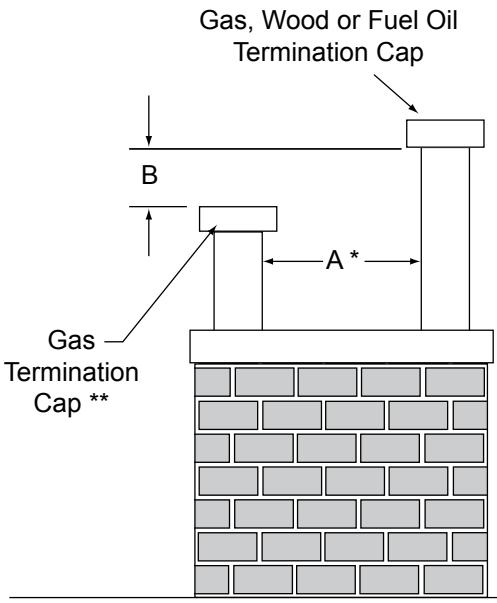

* If using decorative cap cover(s), this distance may need to be increased. Refer to the installation instructions supplied with the decorative cap cover.

** In a staggered installation with both gas and wood or fuel oil terminations, the wood or fuel oil termination cap must be higher than the gas termination cap.

Figure 4.2 Staggered Termination Caps

B. Chimney Diagram

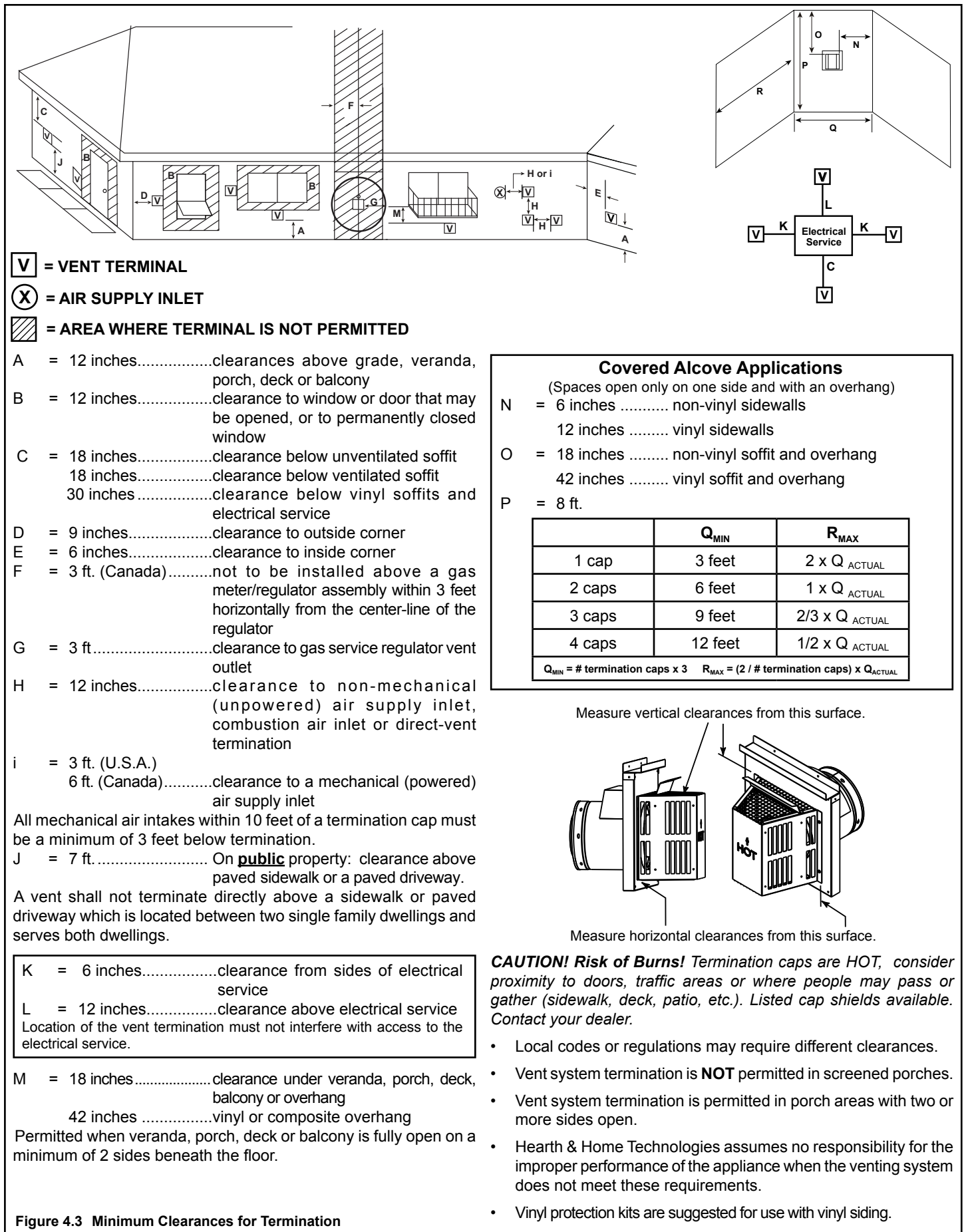

C. Approved Pipe

This appliance is approved for use with Hearth & Home Technologies SLP venting systems. Refer to Section 11.A for vent component information and dimensions.

DO NOT mix pipe, fittings or joining methods from different manufacturers.

The pipe is tested to be run inside an enclosed wall. There is no requirement for inspection openings at each joint within the wall.

WARNING! Risk of Fire or Asphyxiation. *This appliance requires a separate vent. DO NOT vent to a pipe serving a separate solid fuel burning appliance.*

DO NOT USE FIELD-FABRICATED VENTING COMPONENTS.

This product is approved to be vented either horizontally, through the side wall or vertically through the roof. You may vent through a Class A or masonry chimney if an approved adapter is used.

This appliance is a direct vent heater. All combustion air must come directly from the outside of the building. The vent pipe for this unit consists of an inner and an outer pipe. The inner pipe carries the appliance exhaust out of the system, and the outer pipe brings fresh combustion air into the appliance.

- A round support box/wall thimble or heat shield is required when the venting passes through a combustible wall.
- A support box or ceiling firestop is required when the venting passes through a ceiling.
- Roof flashing and a storm collar are required when venting passes through the roof.
- Follow instructions provided with the venting for installation of these items.

D. Use of Elbows

Diagonal runs have both vertical and horizontal vent aspects when calculating the effects. Use the rise for the vertical aspect and the run for the horizontal aspect. See Figure 4.4.

Two 45° elbows may be used in place of one 90° elbow. On 45° runs, one foot of diagonal is equal to 8-1/2 in. (216 mm) horizontal run and 8-1/2 in. (216 mm) vertical run. A length of straight pipe is allowed between two 45° elbows. See Figure 4.4.

Figure 4.5 shows the vertical and horizontal offsets for SLP elbows.

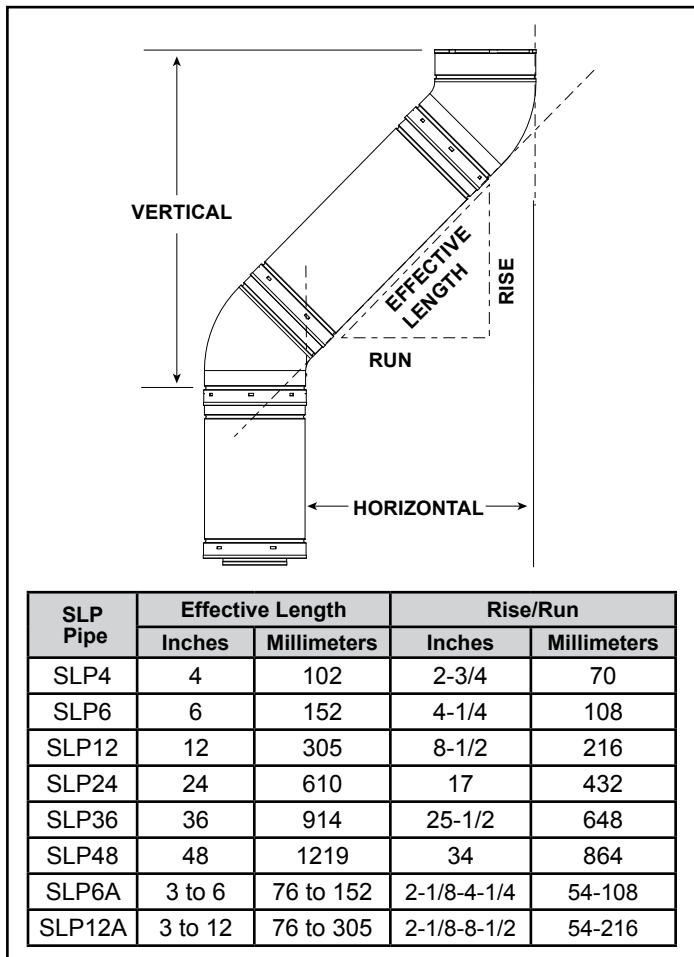

Figure 4.4

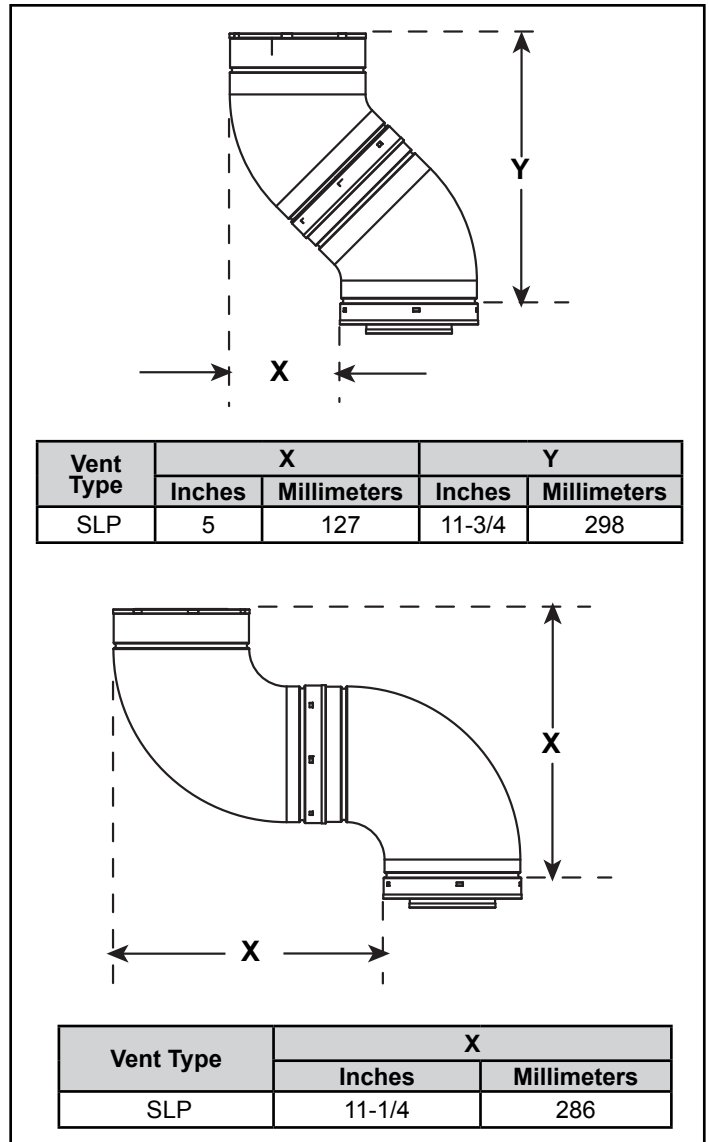

Figure 4.5 Vertical and Horizontal Offset for SLP Elbows

E. Measuring Standards

Vertical and horizontal measurements listed in the vent diagrams were made using the following standards:

- Pipe measurements are shown using the effective length of pipe. See Figure 11.1 for SLP for information on effective length of pipe components.
- Horizontal terminations are measured to the outside mounting surface (flange of termination cap) (see Figure 4.3).
- Vertical terminations are measured to bottom of termination cap.
- Horizontal pipe installed level with 1/4 inch rise per foot.

F. Venting Guidelines for Horizontal Runs

Max Horizontal Run, Rear Vent (No Rise)	8 in. (203 mm) See Figure 4.6.
Max Horizontal Run	8 ft (2.4 m) when vertical rise is 8 ft (2.4 m)
Rear Vent with Vertical Rise	Min of 2 ft vertical (610 mm) must be used prior to any horizontal run. See Figure 4.6.
Horizontal Run requires a non-combustible support every 3 ft (914 mm), i.e., plumbing tape	

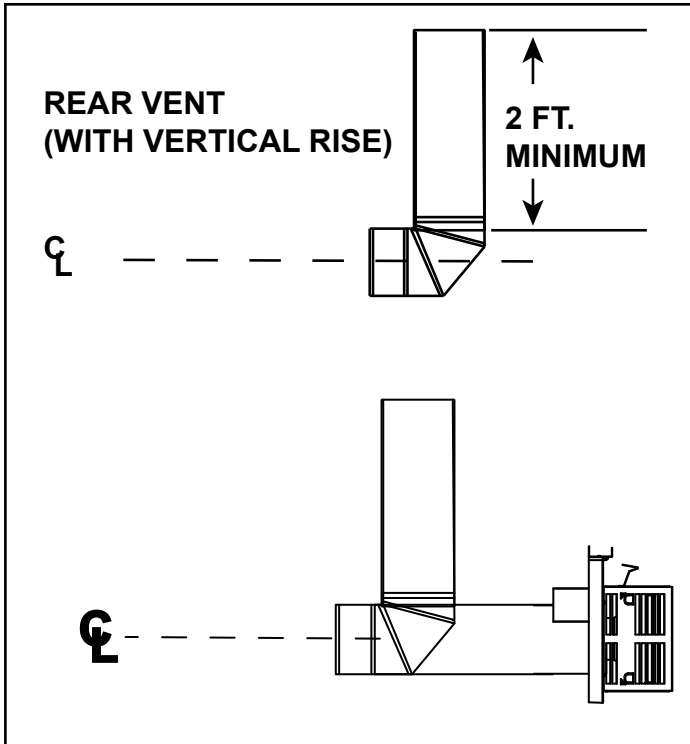

Figure 4.6

G. Vent Diagrams

General Rules:

- SUBTRACT 3 ft. from the total H measurement for each 90° elbow installed horizontally.
- SUBTRACT 1 ft. from the total H measurement for each 45° elbow installed horizontally.
- A maximum of three 90° elbows (or six 45° elbows) may be used in any vent configuration. Some elbows may be installed horizontally. See specific vent diagrams.
- When penetrating a combustible wall, a wall shield firestop must be installed.
- When penetrating a combustible ceiling, a ceiling firestop must be installed.

Rear Vent - Horizontal Termination

$H_1 = 8 \text{ in. (203 mm) Maximum}$

No Elbow

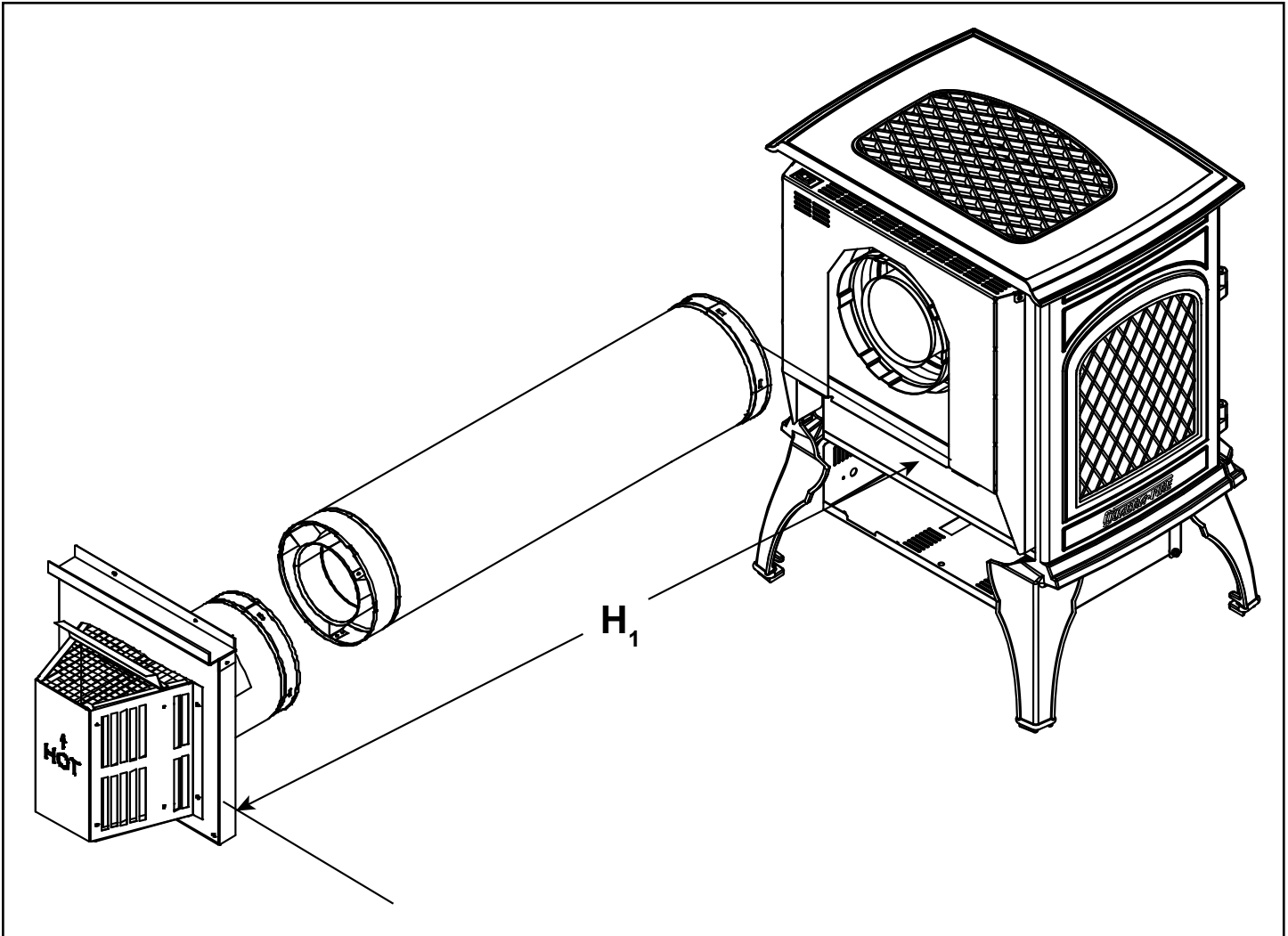

Figure 4.7

Rear Vent - Horizontal Termination - (continued)

Two Elbows

2 Elbows to Max. Horizontal					
V_1 Minimum		H_1 Maximum		$H_1 + H_2$ Maximum	
2 ft.	.61 m	8 in.	203 mm	18 in.	.46 m
4 ft.	1.2 m	8 in.	203 mm	3 ft., 3 in.	1 m
6 ft.	1.8 m	8 in.	203 mm	6 ft.	1.8 m
8 ft.	2.4 m	8 in.	203 mm	8 ft.	2.4 m
10 ft.	3.1 m	8 in.	203 mm	7 ft., 3 in.	2.2 m
12 ft.	3.7 m	8 in.	203 mm	6 ft., 4 in.	1.9 m
14 ft.	4.3 m	8 in.	203 mm	5 ft., 5 in.	1.6 m
16 ft.	4.9 m	8 in.	203 mm	4 ft., 6 in.	1.4 m
18 ft.	5.5 m	8 in.	203 mm	3 ft., 7 in.	1.0 m
20 ft.	6.1 m	8 in.	203 mm	2 ft., 8 in.	813 mm
22 ft.	6.7 m	8 in.	203 mm	1ft., 10 in.	559 mm

Note: Flue restrictor may need to be adjusted as vertical dimension increases.

Note: For optimum flame appearance, air shutter may need to be adjusted as vertical dimension increases.

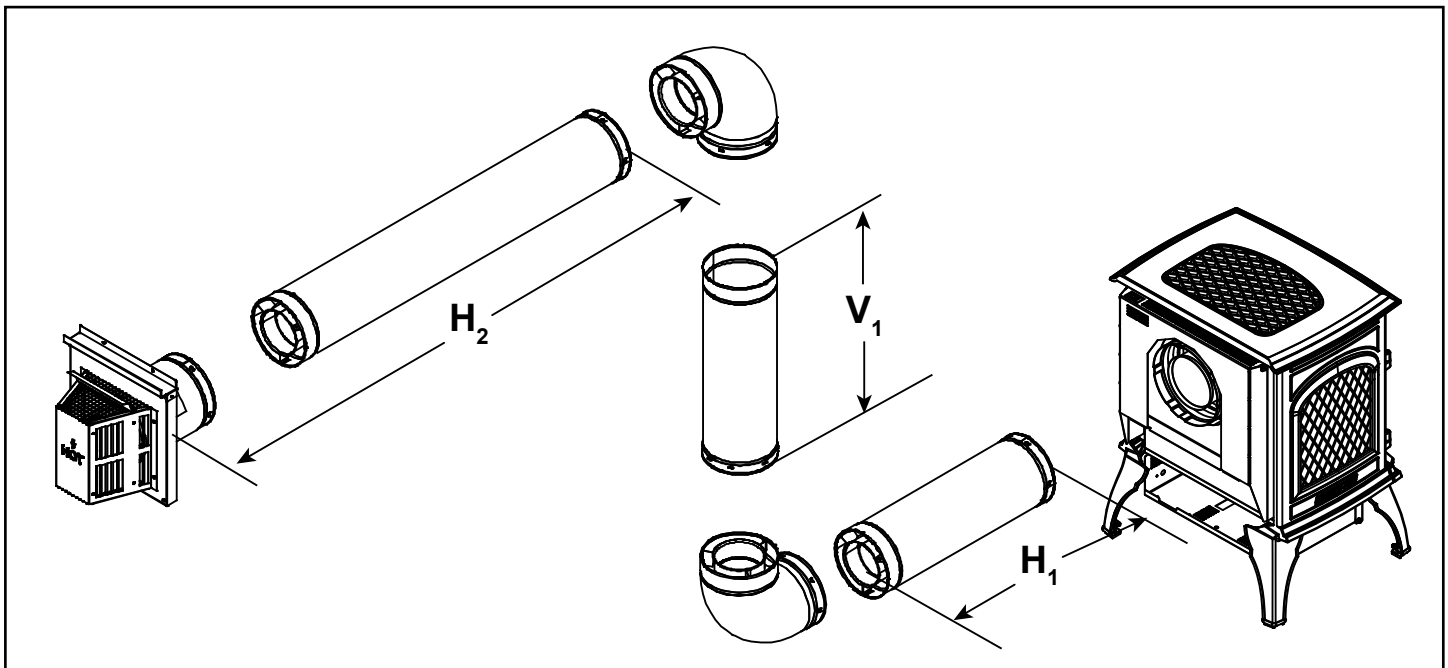

Figure 4.8

Three Elbows

3 Elbows to Max. Horizontal					
V_1 Minimum		H_1 Maximum		H_{Total}	
6 ft.	1.8 m	8 in.	203 mm	3 ft.	914 mm
8 ft.	2.4 m	8 in.	203 mm	5 ft.	1.5 m
10 ft.	3.1 m	8 in.	203 mm	4ft., 3 in.	1.3 m
12 ft.	3.7 m	8 in.	203 mm	3 ft., 4 in.	1.0 m
14 ft.	4.3 m	8 in.	203 mm	2 ft., 5 in.	737 mm
16 ft.	4.9 m	8 in.	203 mm	1ft., 6 in.	457 mm

Note: Flue restrictor may need to be adjusted as vertical dimension increases.

Note: For optimum flame appearance, air shutter may need to be adjusted as vertical dimension increases.

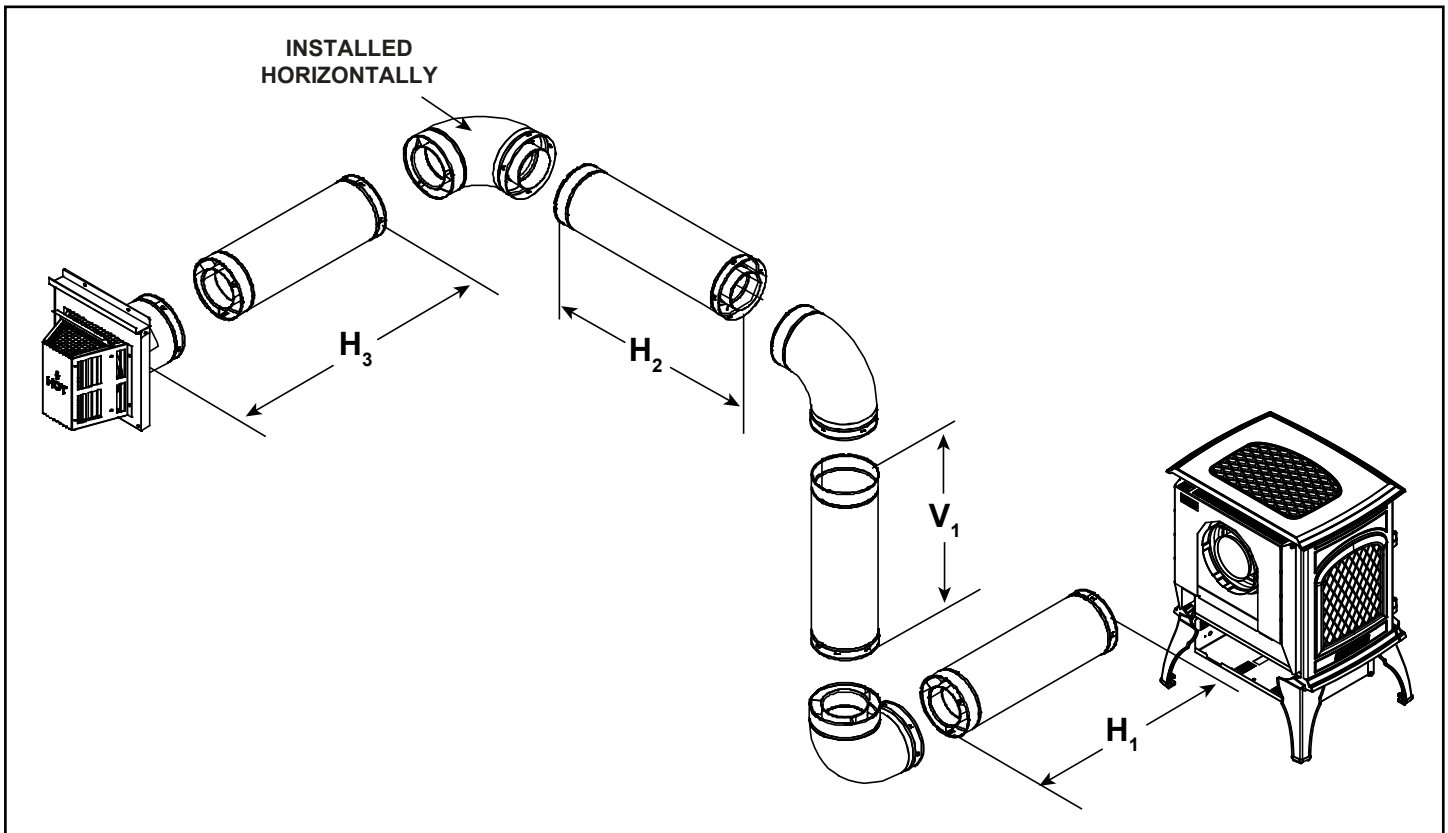

Figure 4.9

Rear Vent - Vertical Termination

One Elbow

H ₁ Minimum		H ₁ Maximum		V ₁ Minimum		V ₁ Maximum	
6 in.	152 mm	14 in.	357 mm	6 ft.	1.8 m	25 ft.	7.6 m

Note: Flue restrictor may need to be adjusted as vertical dimension increases.

Note: For optimum flame appearance, air shutter may need to be adjusted as vertical dimension increases.

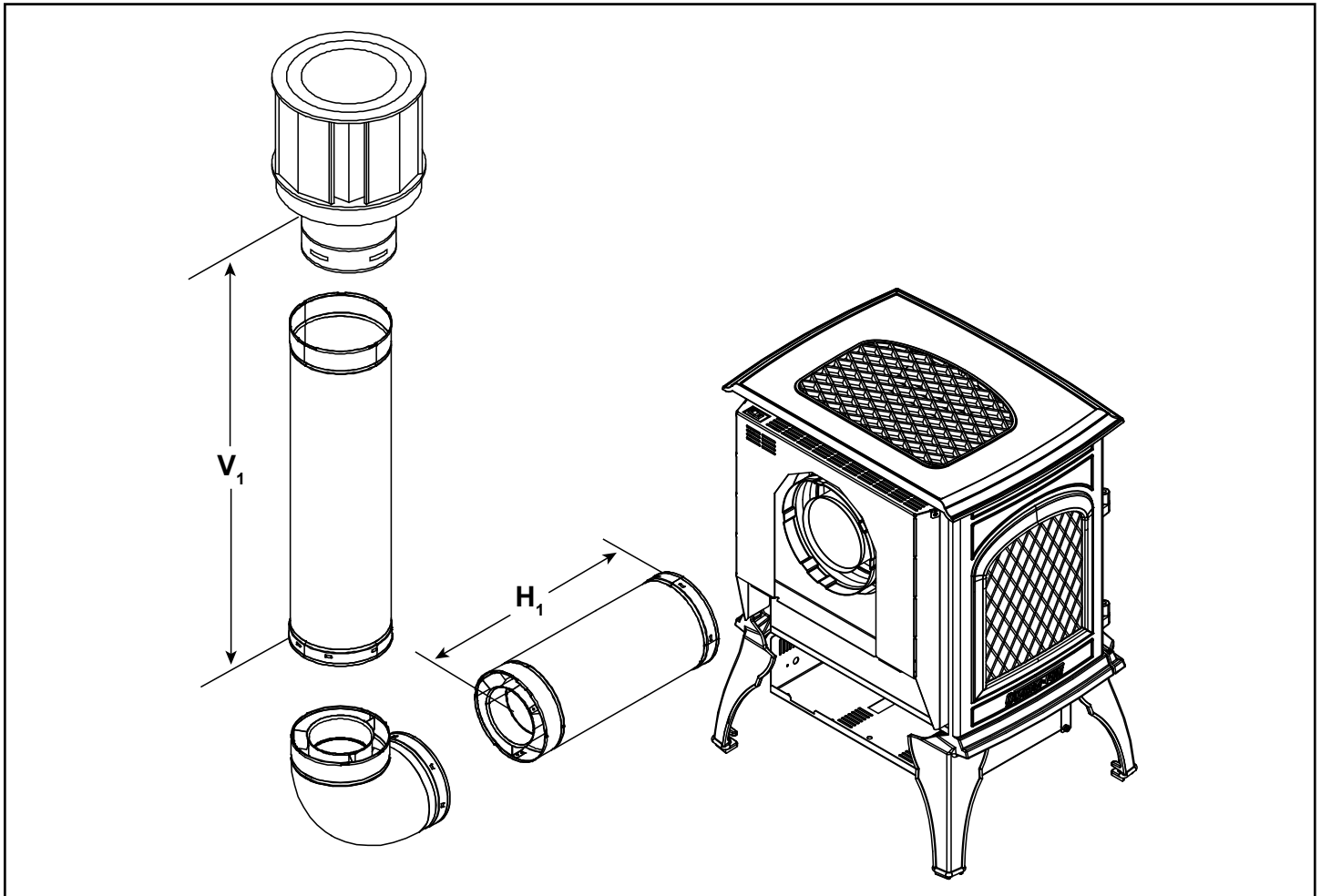

Figure 4.10

Rear Vent - Vertical Termination - (continued)

Three Elbows

3 Elbows to Maximum Vertical							
V_1 Minimum		H_1 Maximum		H_{Total}		$V_1 + V_2$ MAXIMUM	
6 ft.	1.8 m	8 in.	203 mm	3 ft.	914 mm	19 ft., 7 in.	6.0 m
8 ft.	2.4 m	8 in.	203 mm	5 ft.	1.5 m	14 ft., 11 in.	4.5 m
10 ft.	3.1 m	8 in.	203 mm	4 ft., 3 in.	1.3 m	16 ft., 10 in.	5.1 m
12 ft.	3.7 m	8 in.	203 mm	3 ft., 4 in.	1.0 m	19 ft.	5.8 m
14 ft.	4.3 m	8 in.	203 mm	2 ft. 5 in.	737 mm	20 ft., 9 in.	6.3 m
16 ft.	4.9 m	8 in.	203 mm	1 ft., 6 in.	457 mm	23 ft., 2 in.	7.1 m

Note: Flue restrictor may need to be adjusted as vertical dimension increases.

Note: For optimum flame appearance, air shutter may need to be adjusted as vertical dimension increases.

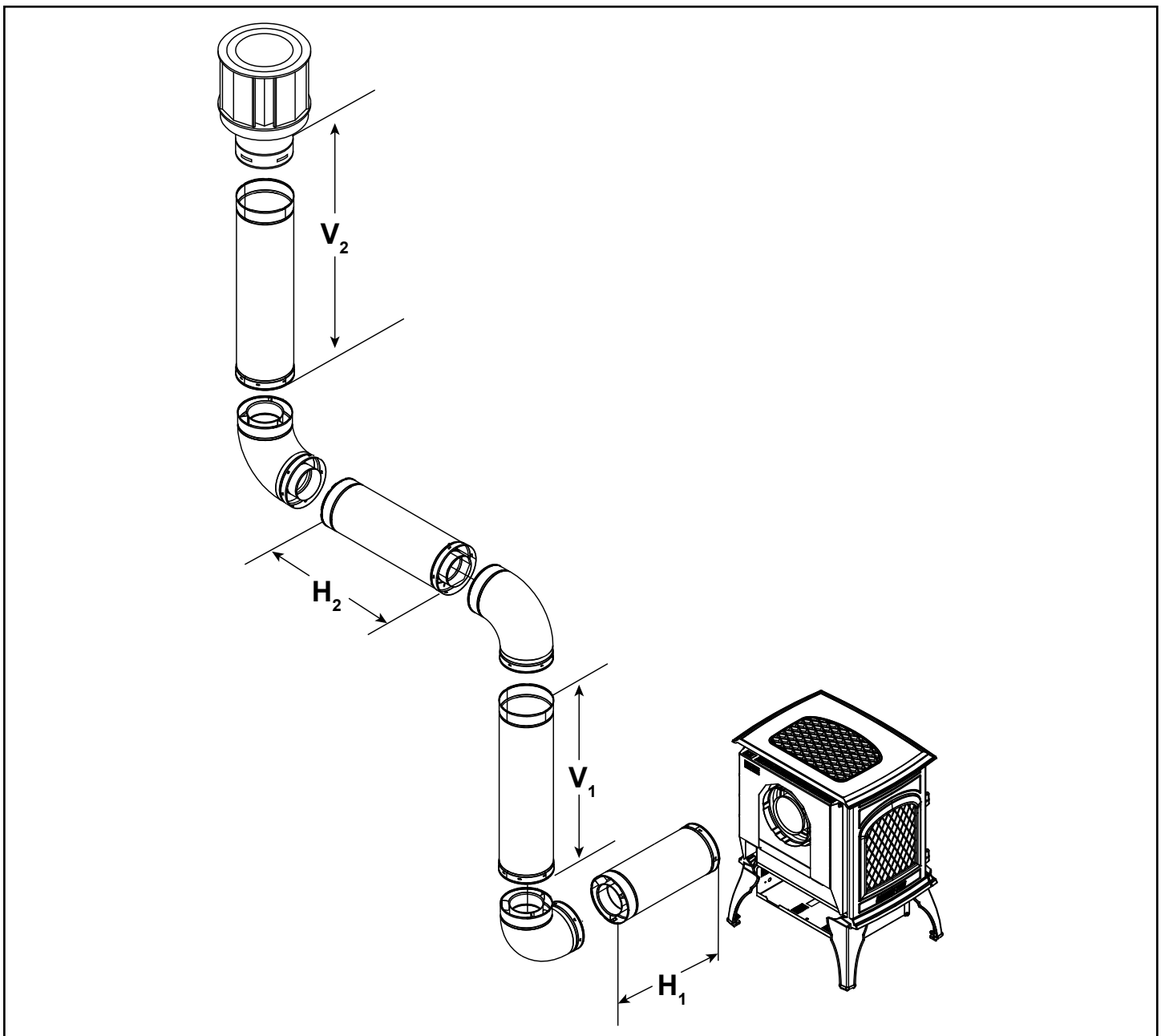

Figure 4.11

Class A Metal Chimney

Prior to installing the gas stove, ensure that the existing chimney is functionally sound and clean.

- Have the chimney and adjacent structure inspected and cleaned by qualified professionals. Hearth & Home Technologies recommends that NFI or CSIA certified professionals, or technicians under the direction of certified professionals, conduct a minimum of a NFPA 211 Level 2 inspection of the chimney.
- Replace component parts of the chimney and fireplace as specified by the professionals.

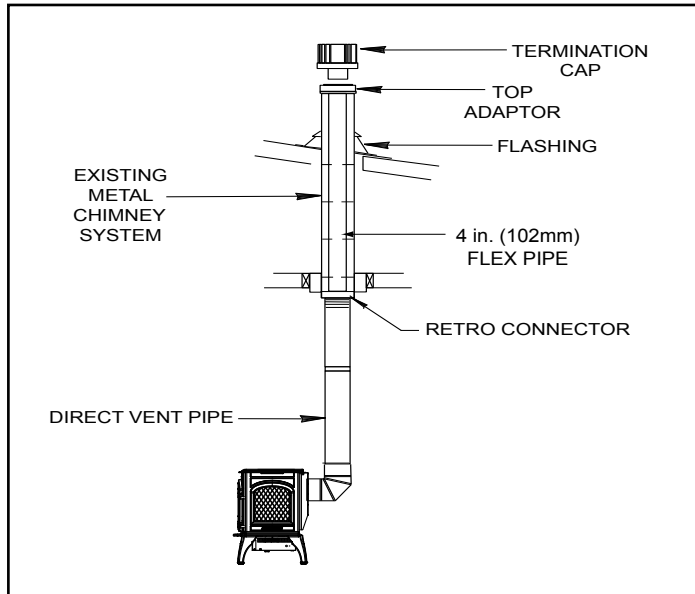

Figure 4.12

1. Remove existing chimney cap.
2. Measure the distance from the top of the chimney to the bottom of the ceiling support box, add 3 in. (76mm) to this measurement, and cut a section of 4 in. (101mm) flex pipe to that length (the flex should be fully extended).
3. Connect the end of the flex pipe section to the underside of the top adaptor, using four sheet metal screws. See Figure 4.13.
4. Pass the flex pipe down through the center of the chimney system, and center the top adaptor on the top of the chimney pipe. Drill four 1/8 in. (3mm) diameter holes through the top adaptor, and into the chimney top, preferably from the side of the top adaptor. Ensure that you are drilling into the metal on the chimney. Twist lock the high wind termination cap onto the top adaptor. See Figure 4.14 and Figure 4.15.

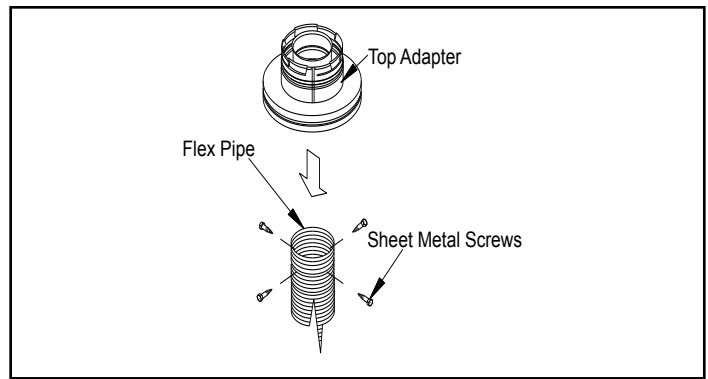

Figure 4.13

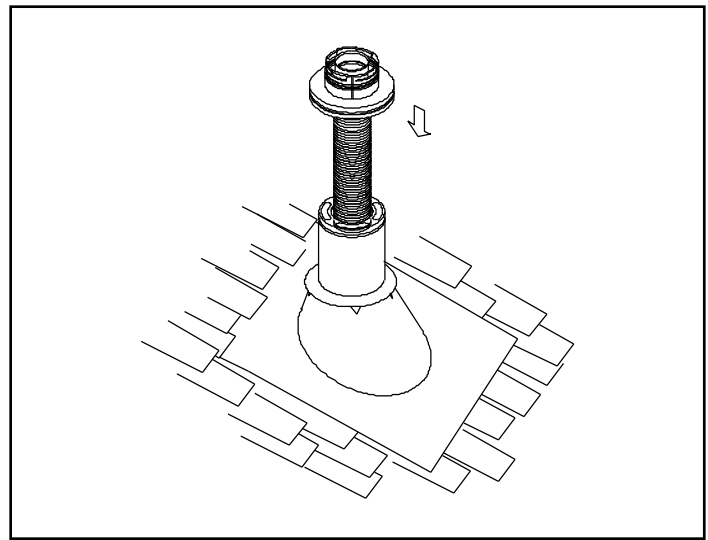

Figure 4.14

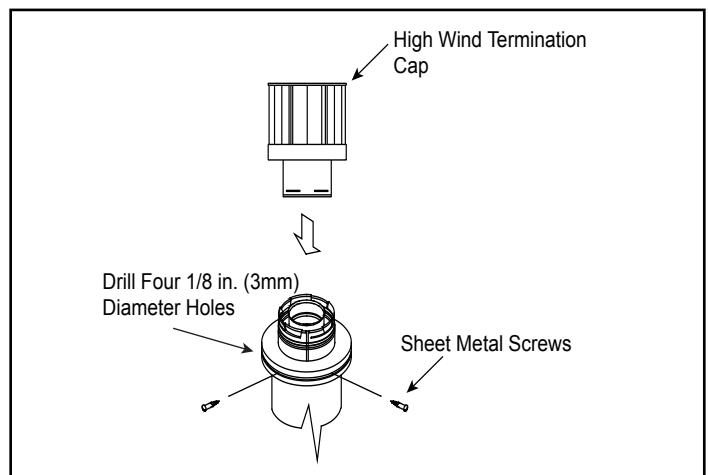

Figure 4.15

5. Pull the flex pipe down through the ceiling support box, until it protrudes approximately 3 in. (76mm). Connect the flex pipe to the retro connector, and attach with sheet metal screws.
6. Push the flex pipe back up into the ceiling support box, center the retro connector, and attach it to the support box with sheet metal screws.
7. The connection between the appliance and the retro connector may be completed with sections of direct vent pipe.

Existing Masonry Chimney

Prior to installing the gas stove, ensure that the existing chimney is functionally sound and clean.

- Have the chimney and adjacent structure inspected and cleaned by qualified professionals. Hearth & Home Technologies recommends that NFI or CSIA certified professionals, or technicians under the direction of certified professionals, conduct a minimum of a NFPA 211 Level 2 inspection of the chimney.
- Replace component parts of the chimney and fireplace as specified by the professionals.

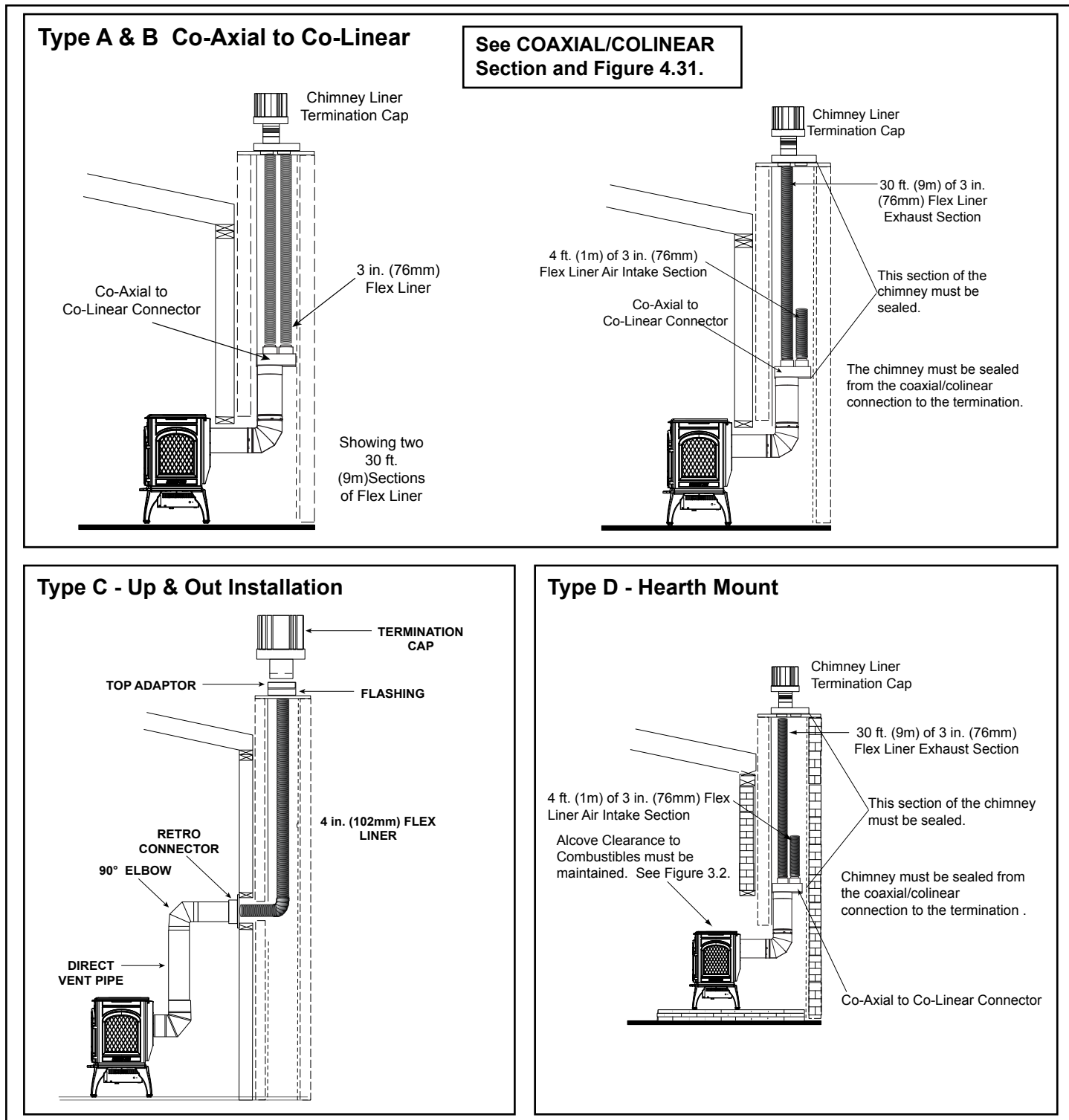

Figure 4.16

1. Before cutting any holes, assemble the desired sections of direct vent pipe to determine the center of the masonry penetration.
2. Once the center point of the penetration has been determined, cut a 6 in. (152mm) diameter hole in the masonry. If the hole is too large, the retro connector might not mount properly; if the hole is too small, the appliance might starve for intake air. If there is a frame wall in front of the masonry wall, cut and frame a 10 in. (254mm) square opening in the wall (centered around the 6 in. (152mm) masonry opening). If there is sheet rock only (no studs) in front of the masonry the 10 in. (254mm) opening is still needed, but does not need to be framed. If the hole is framed a wall thimble is required. This allows the retro connector to mount directly on the masonry and provide the correct clearances to combustibles. See Figure 4.17.

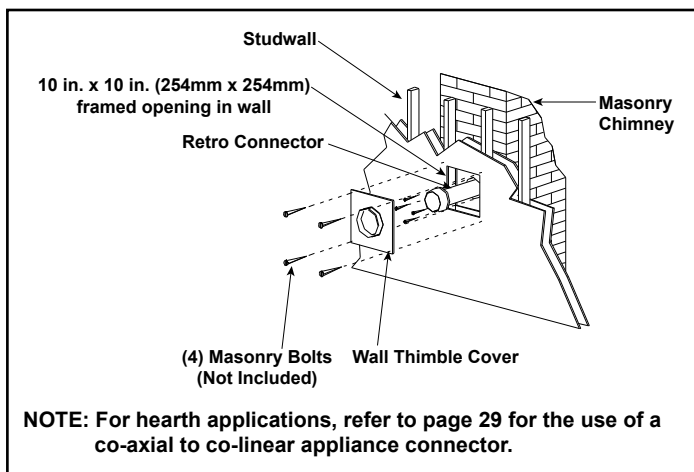

Figure 4.17

3. Secure the flashing to the top of the masonry chimney using a bead of non-hardening sealant-adhesive. If the flashing is larger than the top of the chimney, cut and fold flashing as needed to fit chimney. See Figure 4.18.

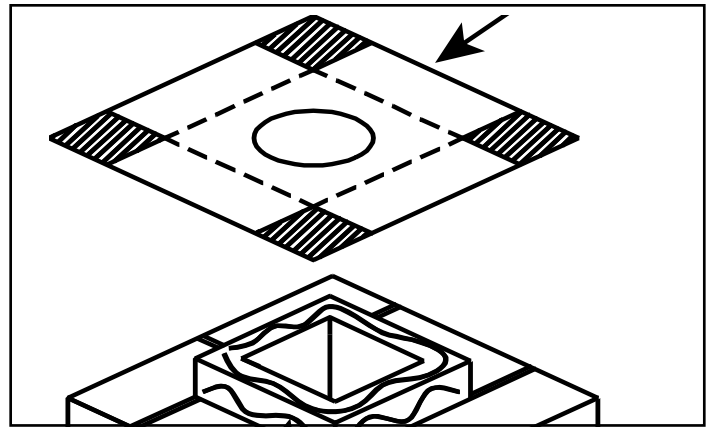

Figure 4.18

4. To determine the length of flex needed, measure from 3 in. (76mm) above the top of the flashing down to the level of the opening. Add the distance from the center of the chimney out through the wall. Cut a piece of 4 in. (102mm) flex to this length (extended to its nominal length). Be sure to leave 2-3 in. (51-76mm) of flex above the existing chimney to allow for connection to the termination kit.
5. Connect the flex liner to the top adapter using three sheet metal screws. See Figure 4.13.
6. Feed the flex liner through the flashing into the chimney. Carefully feed the flex liner down the chimney to the bottom and out the opening in the masonry wall, forming an angle to line up the flex liner with the vent opening on the appliance.

WARNING! Risk of Fire, Explosion or Asphyxiation! Improper support may allow vent to sag and separate. Use vent run supports and connect vent sections per installation instructions. **DO NOT** allow vent to sag below connection point to appliance.

7. If additional lengths of flex liner are needed to span the chimney height, use a flex coupler to connect the pieces of flex liner together. Connect the flex to the coupler by using four sheet metal screws for each side. See Figure 4.19.

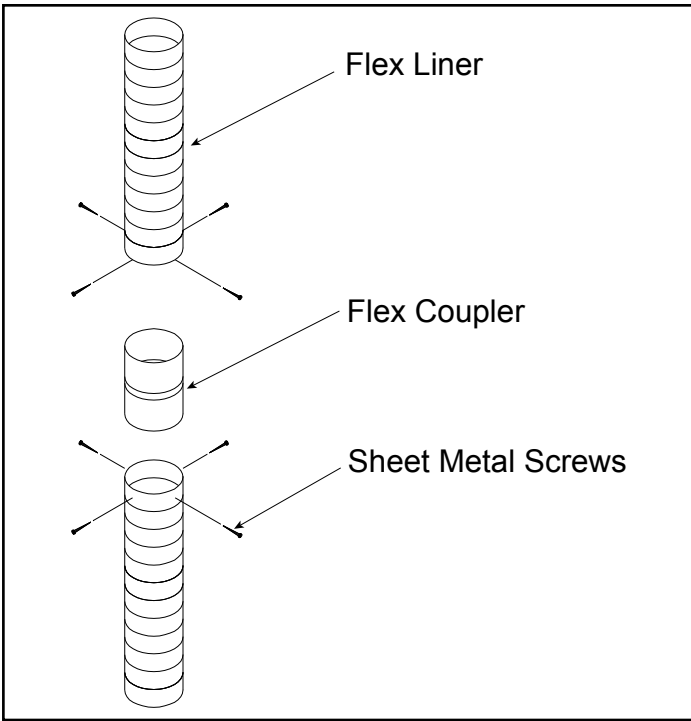

Figure 4.19

8. Secure the top adapter to the flashing. Use three sheet metal screws through the side of the top adapter into the flange on the flashing. See Figure 4.20. Twist lock the high wind termination cap on to the top adapter.

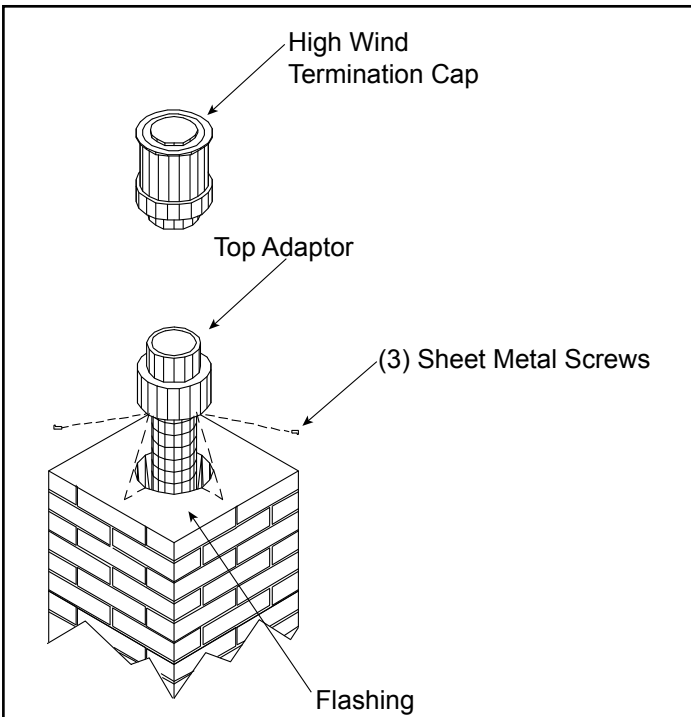

Figure 4.20

9. Attach the flex to the retro connector. Use three sheet metal screws to attach the flex liner to the connector. Mount the retro connector to the masonry wall using masonry bolts. See Figure 4.21. Redrill larger holes on connector as needed. Be careful to ensure that the connector is centered in the opening and the mounting holes line up with the masonry wall.

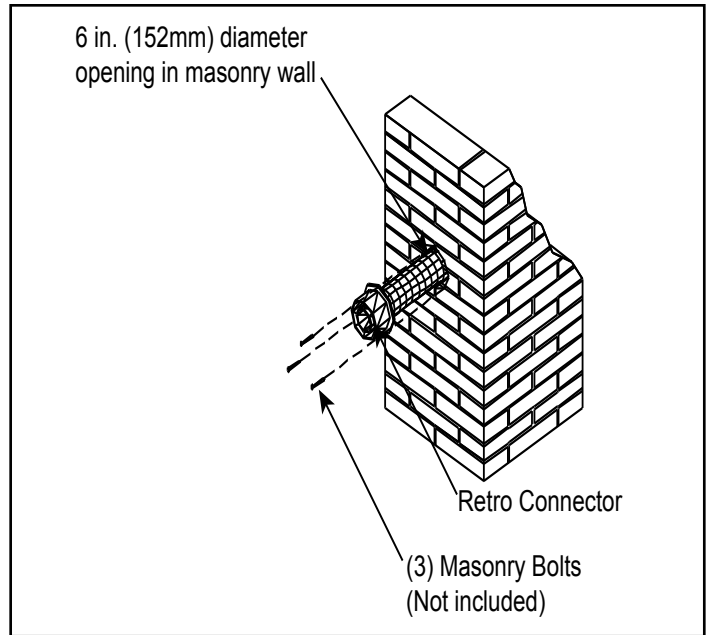

Figure 4.21

10. Slide wall thimble cover over retro connector and secure with masonry bolts. See Figure 4.22. If you have a framed wall in front of the masonry, use wood screws to mount wall thimble cover to framed wall, over retro connector and 10 in. (254mm) square framed opening. See Figure 4.17. If needed, add a section of direct vent pipe to the retro connector in order to extend through the opening in the wall thimble cover.
11. The connection between the appliance and the retro connector may be completed with sections of direct vent pipe.

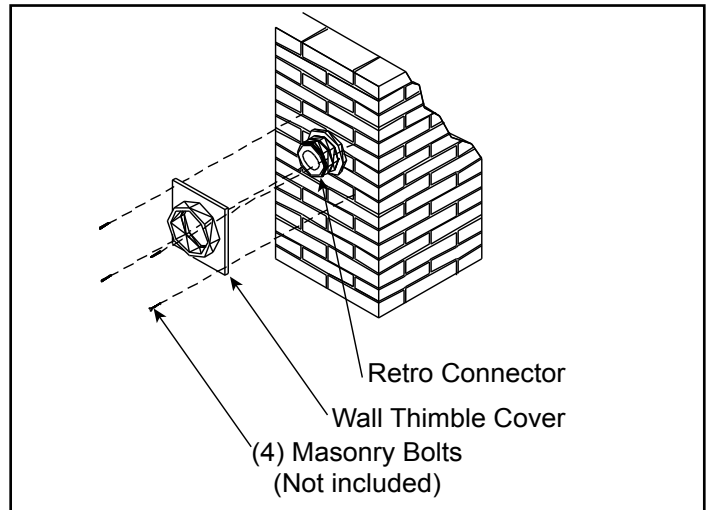

Figure 4.22

Coaxial to Colinear Venting

The coaxial to colinear adapter (DV-46DVA-GCL) is approved for installations into solid fuel masonry or factory built fireplaces that have been installed in accordance with the National, Provincial, State and local building codes.

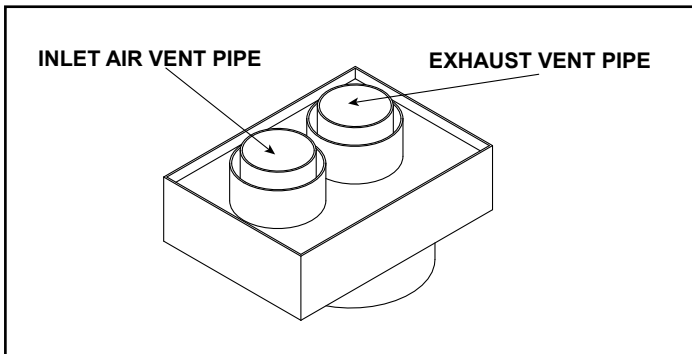

Figure 4.23 Coaxial/Colinear Appliance Connector

WARNING! Risk of Fire! Coaxial to colinear venting configuration may only be used in existing non-combustible chimney. Installation in any other venting application could cause fire.

CAUTION! DO NOT use any flue restrictor when venting with the DV-46DVA-GCL adapter and LINK-DV30B kit. This may result in poor flame appearance, sooting, pilot malfunction, or overheating.

WARNING! Risk of Fire, Explosion or Asphyxiation! Do NOT connect this gas appliance to a chimney flue serving a separate solid fuel or gas burning appliance.

- May impair safe operation of this appliance or other appliances connected to the flue.
- Vent this appliance directly outside.
- Use separate vent system for this appliance.

5 Vent Clearances and Framing

A. Pipe Clearances to Combustibles

WARNING! Risk of Fire! Maintain air space clearance to vent. DO NOT pack insulation or other combustibles:

- Between ceiling firestops
- Between wall shield firestops
- Around vent system

Failure to keep insulation or other material away from vent pipe may cause overheating and fire.

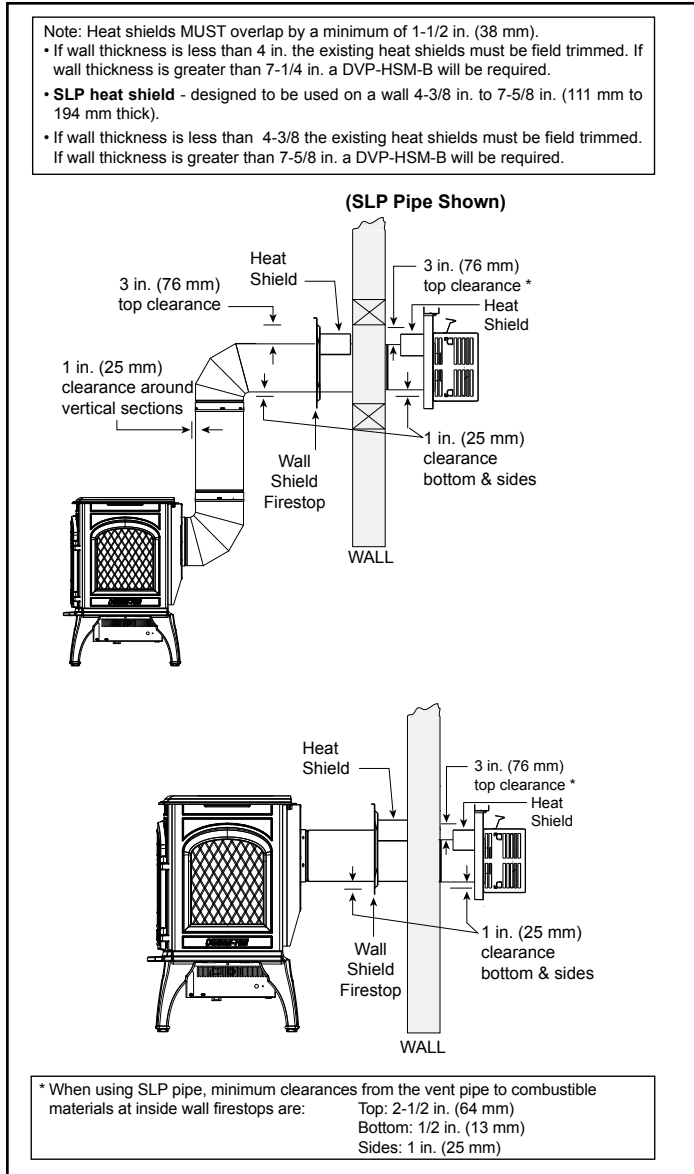

Figure 5.1 Horizontal Venting Clearances To Combustible Materials

B. Wall Penetration Framing/Firestops

Combustible Wall Penetration

Whenever a combustible wall is penetrated, you must frame a hole for the wall shield firestop(s). The wall shield firestop maintains minimum clearances and prevents cold air infiltration.

- The opening must be framed on all four sides using the same size framing materials as those used in the wall construction.
- SLP pipe - A wall shield firestop must be placed on each side of an interior wall. A minimum 1-1/2 in. (38 mm) overlap of attached heat shields must be maintained.
- See Section 7-F for information for regarding the installation of a horizontal termination cap.

Non-Combustible Wall Penetration

If the hole being penetrated is surrounded by non-combustible materials such as concrete, a hole with diameter one inch greater than the pipe is acceptable.

Whenever a non-combustible wall is penetrated, the wall shield firestop is only required on one side and no heat shield is necessary.

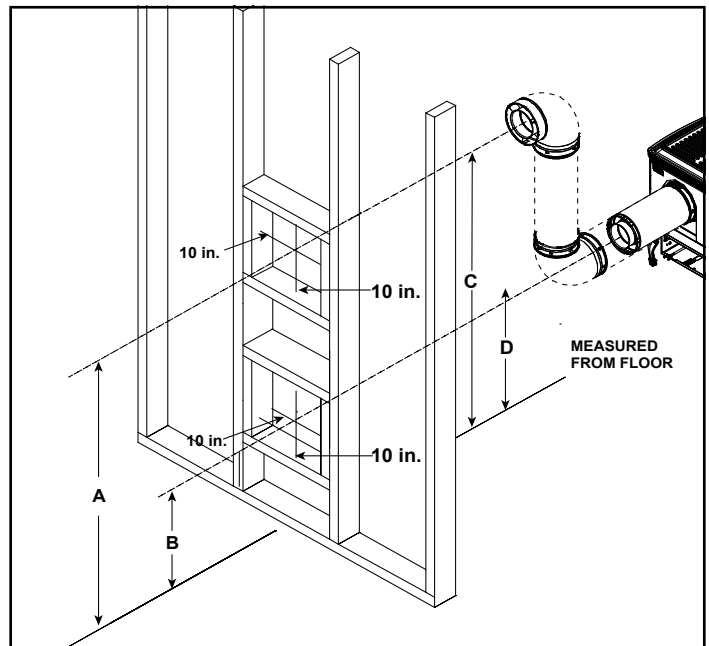

	A	B	C	D
Inches	53-3/4	17-3/4	53-3/4	17-3/4
mm	1365	451	1365	451

Figure 5.2 Wall Penetration

C. Ceiling Firestop/Floor Penetration Framing

A ceiling firestop **MUST** be used between floors and attics.

- **SLP Pipe** - Frame opening 9 in. x 9 in. (229 mm x 229 mm) whenever the vent penetrates a ceiling/floor (see Figure 5.3).
- Frame the area with the same sized lumber as used in ceiling/floor joist.
- The ceiling firestop may be installed above or below the ceiling joists when installed with an attic insulation shield. It must be under joists between floors that are not insulated. Refer to Figure 5.4.
- Secure with three fasteners on each side.

WARNING! Risk of Fire! DO NOT pack insulation around the vent. Insulation must be kept back from the pipe to prevent overheating.

D. Install Attic Insulation Shield

WARNING! Fire Risk. DO NOT allow loose materials or insulation to touch vent. Hearth & Home Technologies requires the use of an attic shield.

The International Fuel Gas Code requires an attic shield constructed of 26 gauge minimum steel that extends at least 2 in. (51 mm) above insulation.

- Attic insulation shields must meet specified clearances to combustible materials and be secured in place.
- An attic insulation shield kit is available from Hearth & Home Technologies. Contact your dealer to order. Install attic insulation shield according to instructions included with kit.

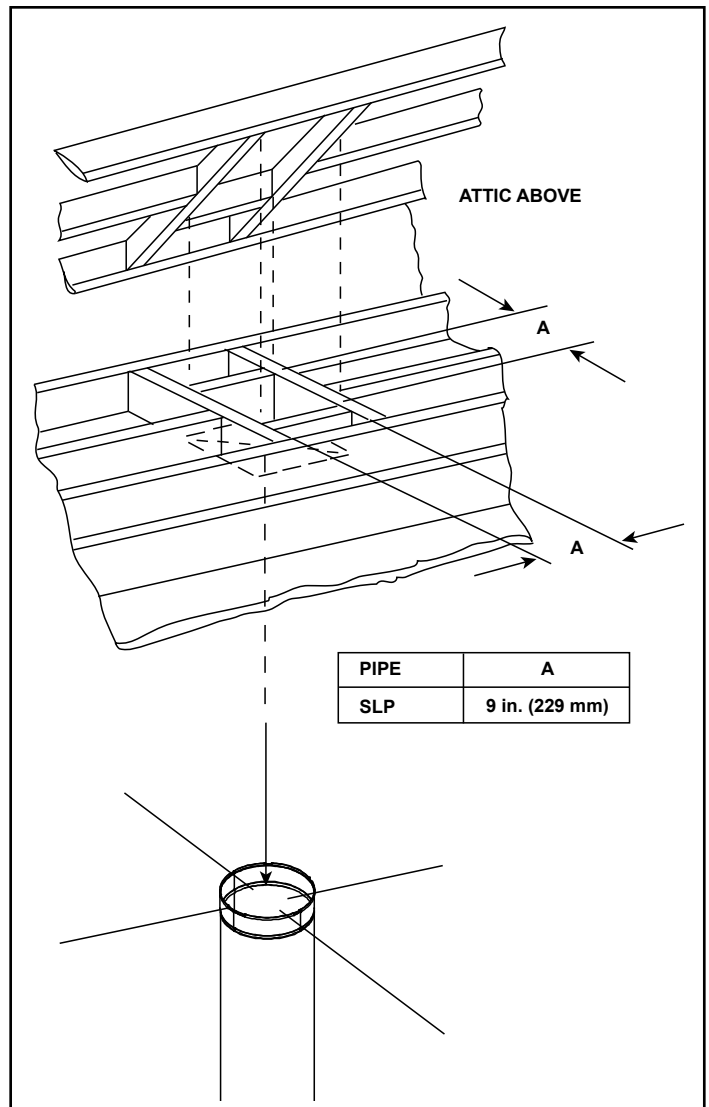

Figure 5.3 Installing Ceiling Firestop

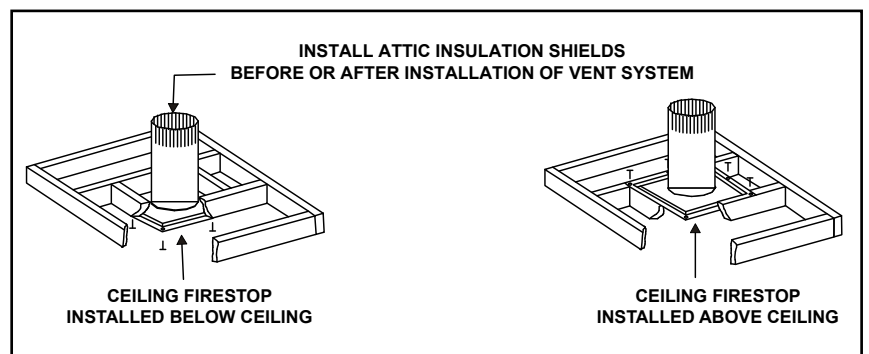

Figure 5.4 Installing the Attic Shield

6 Appliance Preparation

A. Leveling the Appliance

WARNING! Risk of Fire! Prevent contact with combustible materials.

WARNING! Risk of Fire! Failure to maintain air space clearance may cause overheating and fire.

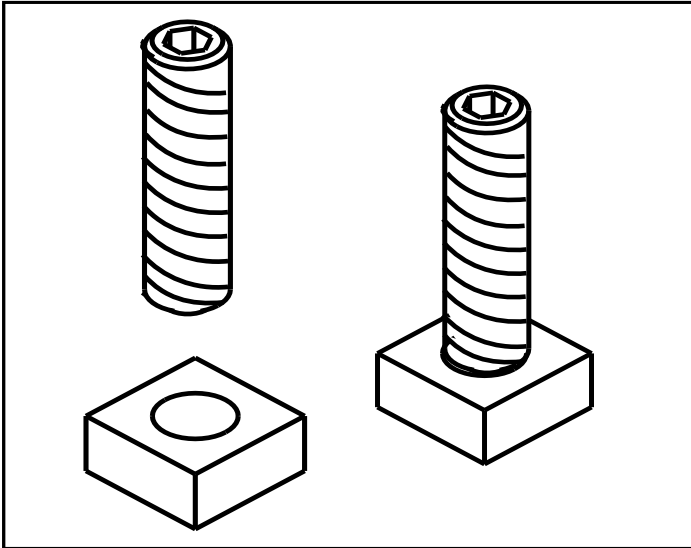

Figure 6.1

1. Thread Allen bolts through nuts until flush.

NOTE: Two Allen bolts and two nuts are included in the component bag. Normally, only one is required on the leg not touching the floor.

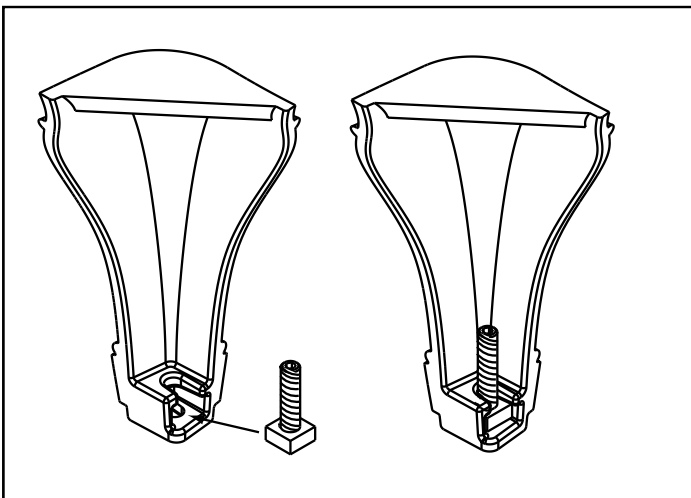

Figure 6.2

2. Slide assembled nuts and bolts into slots on legs with the nuts on the bottom.

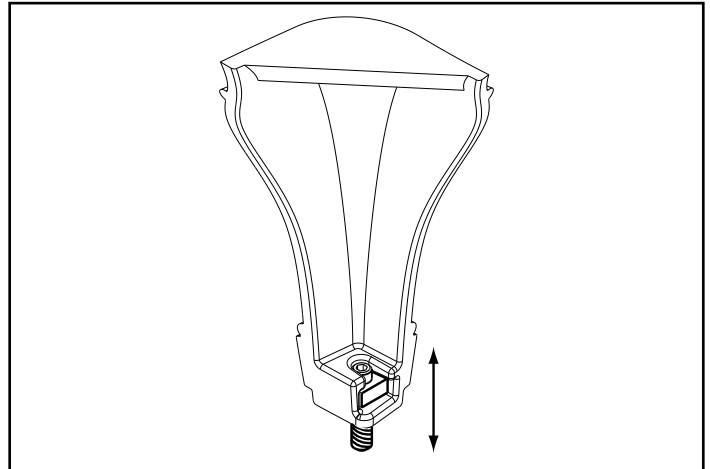

Figure 6.3

3. Use a 5/32 in. (4mm) Allen wrench to adjust legs up and down to desired level.

7 Venting and Chimneys

A. Assemble Vent Sections

To attach the first vent component to the starting collars of the appliance:

- Lock the vent components into place by sliding the pipe section onto the collar.
- Align the seam of the pipe and seam of collar to allow engagement. Rotate the vent component to lock into place. Use this procedure for all vent components. See Figure 7.2.
- Slide the gasket over the first vent section and place it flush to the appliance. This will prevent cold air infiltration. Caulk with a minimum of 300°F continuous exposure rating may be used to hold the part in place.
- Continue adding vent components, locking each succeeding component into place.
- Ensure that each succeeding vent component is securely fitted and locked into the preceding component.

Required Commercial, Multi-family (Multi-level exceeding two stories), or High-Rise Applications

For Installation into a commercial, multi-family (multi-level exceeding two stories) or high-rise applications: All outer pipe joints must be sealed with high temperature silicone (300° F minimum continuous exposure rating), including the slip section that connects directly to the horizontal termination cap.

- Apply a bead of silicone sealant (300° F minimum continuous exposure rating) inside the female outer pipe joint prior to joining sections. See Figure 7.1.
- Only outer pipes need to be sealed. All unit collar, pipe, slip section, elbow and cap outer flues shall be sealed in this manner, unless otherwise stated.

WARNING! Risk of Fire or Explosion! DO NOT break silicone seals on slip sections. Use care when removing termination cap from slip pipe. If slip section seals are broken during removal of the termination cap, vent may leak.

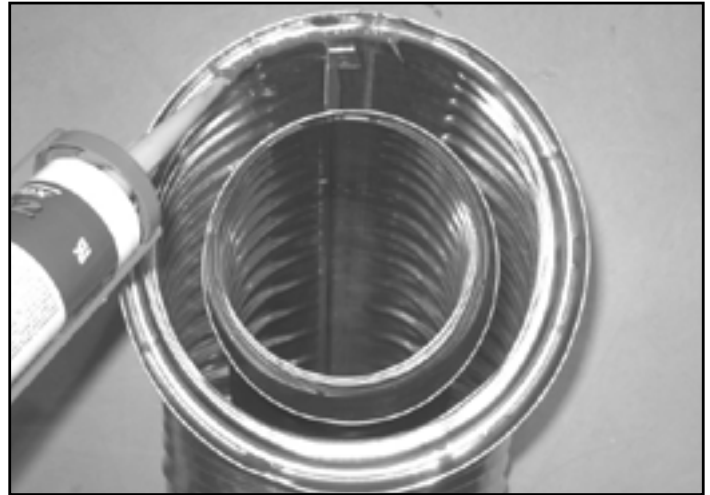

Figure 7.1 High Temperature Silicone Sealant

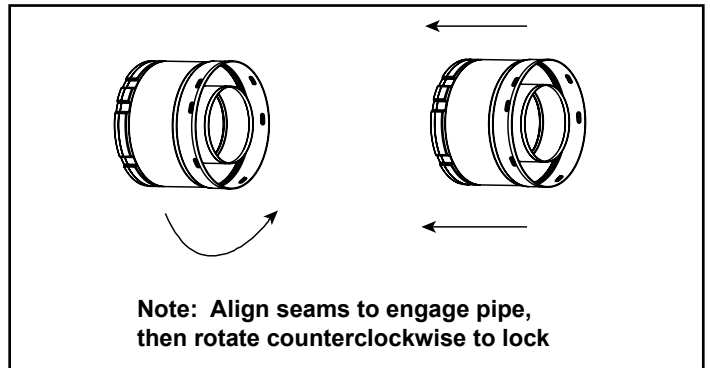

Figure 7.2 Adding Venting Components

B. Assemble Slip Sections

- Slide the inner flue of the slip section into the inner flue of the pipe section and the outer flue of the slip section over the outer flue of the pipe section. See Figure 7.3.
- Slide together to the desired length.



Figure 7.3 Slip Section Pilot Holes

- Maintain a 1-1/2 in. (38 mm) overlap between the slip section and the pipe section.
- Secure the pipe and slip section with two screws no longer than 1/2 in. (13 mm), using the pilot holes in the slip section. See Figure 7.4.



Figure 7.4 Screws into Slip Section

- Continue adding pipe as necessary following instructions in “Assembling Pipe Sections.”

NOTICE: If slip section is too long, the inner and outer flues of the slip section can be cut to the desired length.

- Apply a bead of silicone sealant (300° F minimum continuous exposure rating) inside the female outer pipe joint prior to joining sections.
- Only outer pipes are sealed, sealing the inner flue is not required.
- All unit collar, pipe, slip section, elbow and cap outer flues shall be sealed.

C. Secure the Vent Sections

- Vertical runs originating off the top of the appliance, with no offsets, must be supported every 8 ft. (2.44 m) after the maximum allowed 25 ft. (7.62 m) of unsupported rise.
- Vertical runs originating off the rear of the appliance, or after any elbow, must be supported every 8 ft. (2.44 m).
- Horizontal runs must be supported every 5 feet (1.52 m).
- Vent supports or plumbers strap (spaced 120° apart) may be used to support vent sections. See Figures 7.5 and 7.6.
- Wall shield firestops may be used to provide horizontal support to vent sections.
- SLP ceiling firestops have tabs that may be used to provide vertical support.

WARNING! Risk of Fire, Explosion or Asphyxiation! Improper support may allow vent to sag and separate. Use vent run supports and connect vent sections per installation instructions. **DO NOT** allow vent to sag below connection point to appliance.

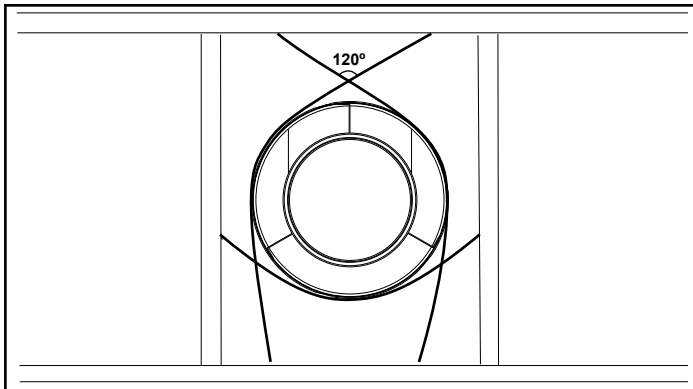

Figure 7.5 Securing Vertical Pipe Sections

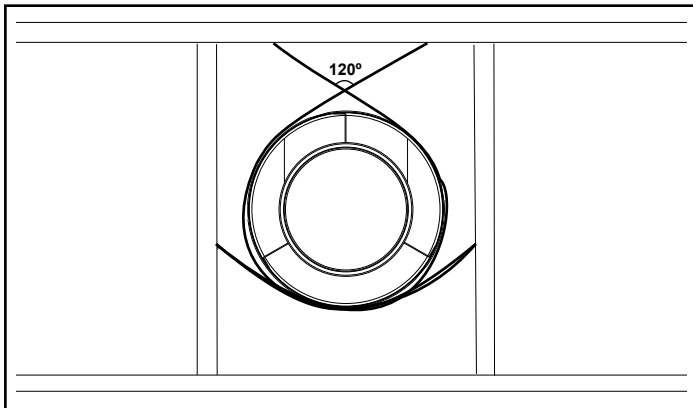

Figure 7.6 Securing Horizontal Pipe Sections

D. Disassemble Vent Sections

- Rotate either section (see Figure 7.7) so the seams on both pipe sections are aligned as shown in Figure 7.8.
- Pull carefully to separate the pieces of pipe.

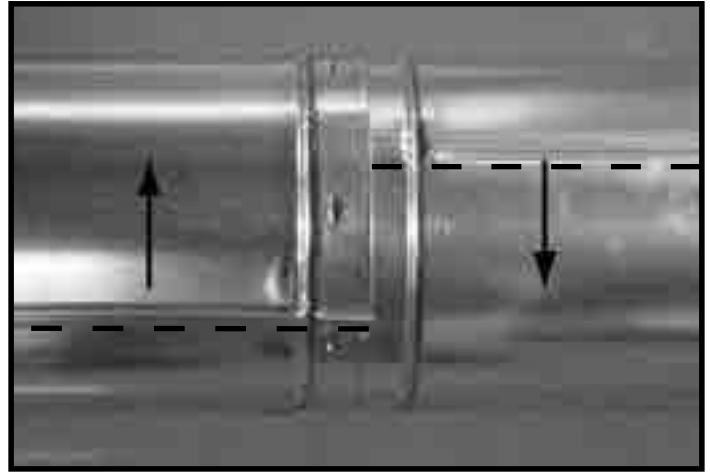

Figure 7.7 Rotate Seams for Disassembly

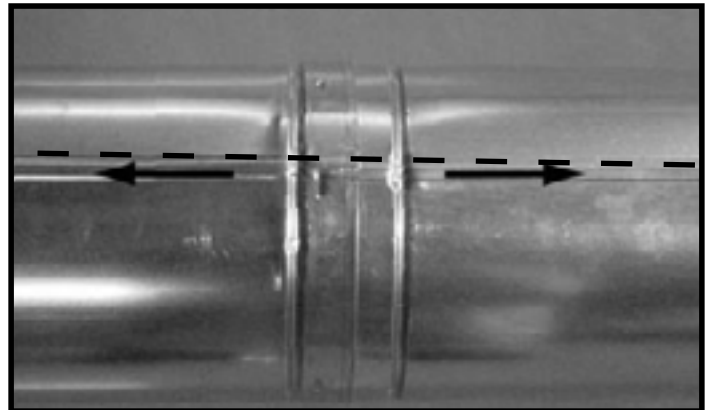

Figure 7.8 Align and Disassemble Vent Sections

Install Decorative Ceiling Components

A decorative ceiling thimble can be installed on a flat ceiling through which the vent passes. The decorative ceiling thimble is used to cover the firestop.

- Seal the gap between the vent pipe and firestop using high temperature silicone (300° F minimum continuous exposure rating) to prevent cold air infiltration.
- Install the decorative ceiling thimble by sliding it up to the ceiling and attaching it using the provided screws.

A decorative cathedral ceiling support box can be installed on a cathedral ceiling through which the vent passes.

- Use a plumb-bob to mark the center line of the venting system on the ceiling and drill a small hole through the ceiling and roof at this point. Locate the hole and mark the outline of the cathedral ceiling support box on the outside roof.
- Remove shingles or other roof covering as necessary to cut the rectangular hole for the support box. Cut the hole 1/8 in. (3 mm) larger than the support box outline.
- Lower the support box through the hole in the roof until its bottom is at least 2 in. (51 mm) below the ceiling (Figure 7.9).
- Level the support box both vertically and horizontally and temporarily tack it in place through the inside walls into the roof sheathing.
- Use tin snips to cut the support box from the top corners down to the roof line and fold the resulting flaps to the roof. See Figure 7.10.
- Nail the flaps to the roof AFTER running a bead of non hardening sealant between the flaps and the roof.

WARNING! Risk of Fire! Clean out ALL materials from inside the support box and complete the vertical vent run and termination.

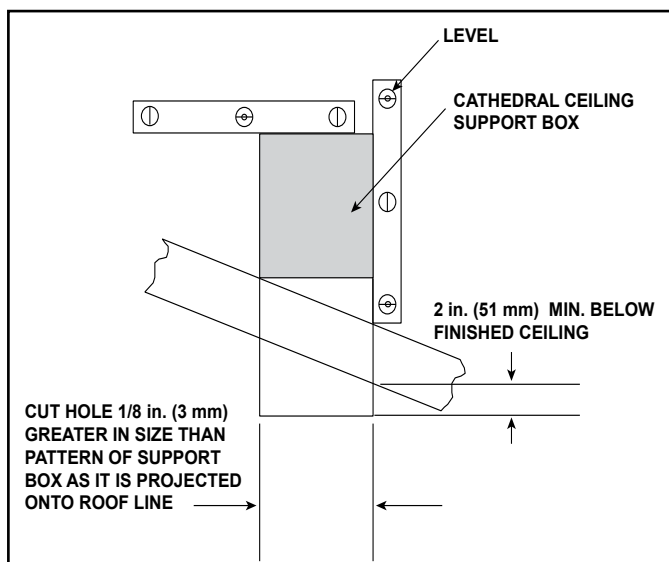

Figure 7.9

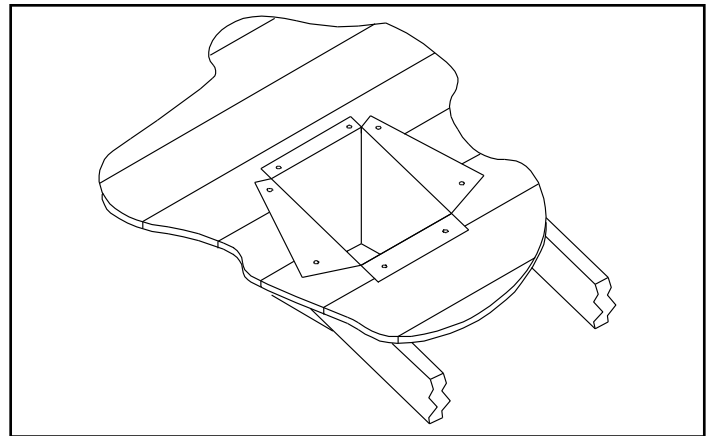

Figure 7.10

E. Vertical Termination Requirements

Install Metal Roof Flashing

- See minimum vent heights for various pitched roofs (Figure 7.11) to determine the length of pipe to extend through the roof.
- Slide the roof flashing over the pipe sections extending through the roof as shown in Figure 7.12.

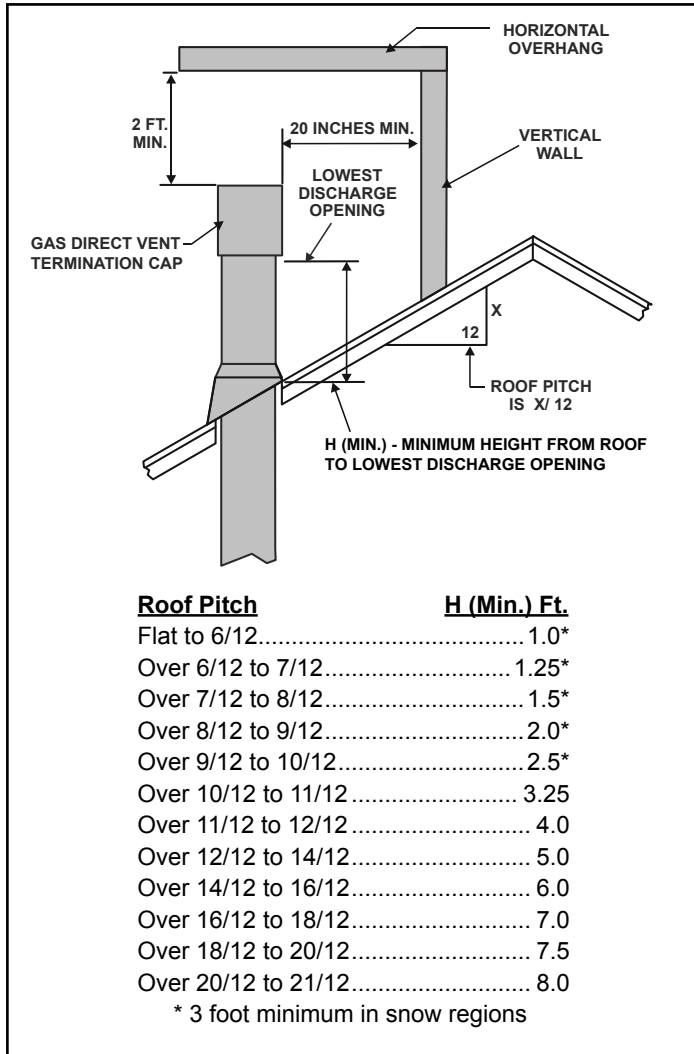

Figure 7.11 Minimum Height From Roof To Lowest Discharge Opening

NOTICE: Failure to properly caulk the roof flashing and pipe seams may permit entry of water.

- Caulk the gap between the roof flashing and the outside diameter of the pipe.
- Caulk the perimeter of the flashing where it contacts the roof surface. See Figure 7.15.
- Caulk the overlap seam of any exposed pipe sections that are located above the roof line.

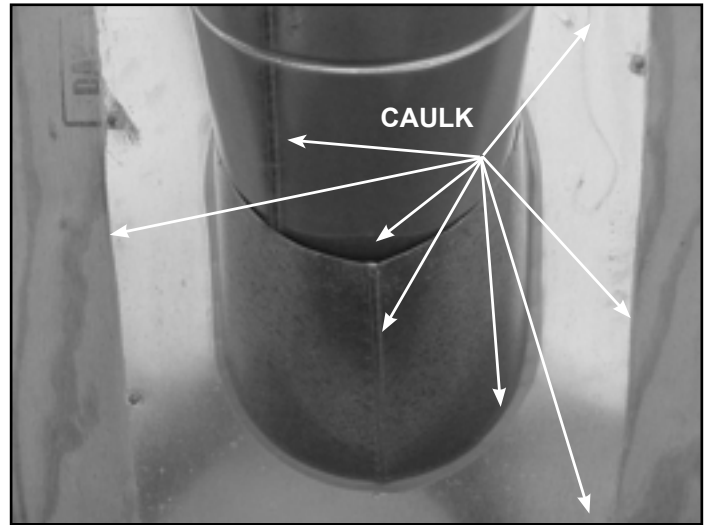

Figure 7.12

- Any occupied areas above the first floor, including closets and storage spaces, which the vertical vent passes through must be enclosed. See Figure 7.13 for required clearances between vent and enclosure.

WARNING! Risk of Fire! Maintain air space clearance to vent. **DO NOT** pack insulation or other combustibles around vent system. Failure to keep insulation or other material away from vent pipe may cause overheating and fire.

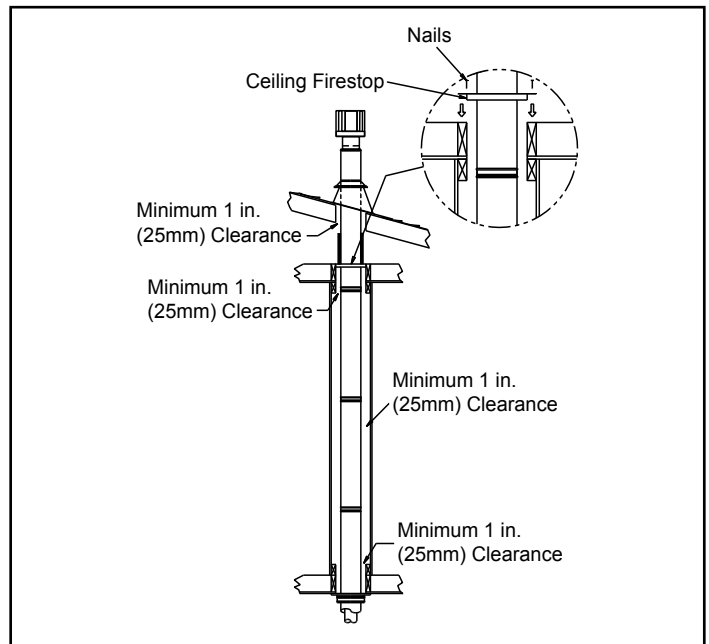

Figure 7.13

Assemble and Install Storm Collar

CAUTION! Risk of Cuts, Abrasions or Flying Debris. Wear protective gloves and safety glasses during installation. Sheet metal edges are sharp.

- Slide the storm collar onto the exposed pipe section and align brackets.
- Insert a bolt (provided) through the brackets and install nut. Do not completely tighten. See Figure 7.14.



Figure 7.14 Insert Bolt into Brackets

- Slide the assembled storm collar down the pipe section until it rests on the roof flashing.
- Tighten nut and make sure the collar is tight against the pipe section.
- Caulk around the top of the storm collar. See Figure 7.15.

Install Vertical Termination Cap

- Attach the vertical termination cap by sliding the inner collar of the cap into the inner flue of the pipe section while placing the outer collar of the cap over the outer flue of the pipe section.
- Secure the cap by driving three self-tapping screws (supplied) through the pilot holes in the outer collar of the cap into the outer flue of the pipe (see Figure 7.15).



Figure 7.15

F. Horizontal Termination Requirements

Install Decorative Wall Components (SLP only)

A decorative wall thimble can be installed on wall through which the vent passes. The decorative wall thimble is used to cover the wall shield firestop.

- Slide the decorative wall thimble over the last section of horizontal pipe before connecting the termination cap to the pipe.
- Once the pipe section and the termination cap have been connected, slide the wall thimble up to the interior wall surface and attach with screws provided. See Figure 7.16.

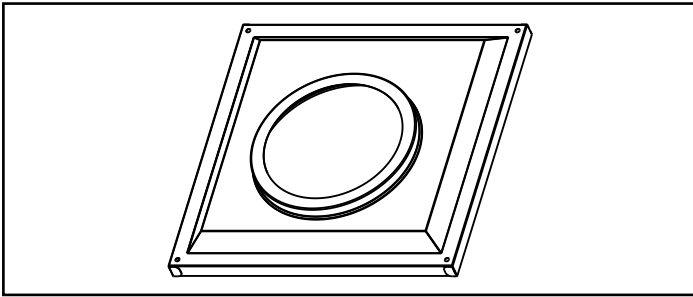

Figure 7.16 Wall Thimble

Heat Shield Requirements for Horizontal Termination

WARNING! Risk of Fire! To prevent overheating and fire, heat shields must extend through the entire wall thickness.

- **DO NOT** remove the heat shields attached to the wall shield firestop and the horizontal termination cap (shown in Figure 7.17).
- Heat shields must overlap 1-1/2 in. (38 mm) minimum.

There are two sections of the heat shield. One section is factory-attached to the wall shield firestop. The other section is factory-attached to the cap. See Figure 7.17.

If the wall thickness does not allow the required 1-1/2 in. (38 mm) heat shield overlap when installed, an extended heat shield must be used.

- If the wall thickness is less than 4-3/8 in./ 111 mm, the heat shields on the cap and wall shield firestop must be trimmed. A minimum 1-1/2 in. (38 mm) overlap **MUST** be maintained.
- Use an extended heat shield if the finished wall thickness is greater than 7-1/4 in. (184 mm).
- The extended heat shield may need to be cut to length maintaining sufficient length for a 1-1/2 in. (38 mm) overlap between heat shields.
- Attach the extended heat shield to either of the existing heat shields using the screws supplied with the extended heat shield. Refer to vent components diagrams in the back of this manual.
- Rest the small leg on the extended heat shield on top of the pipe section to properly space it from the pipe section.

Important Notice: Heat shields may not be field constructed.

Install Horizontal Termination Cap

WARNING! Risk of Fire! The telescoping flue section of the termination cap **MUST** be used when connecting vent.

- 1-1/2 (38 mm) minimum overlap of flue telescoping section is required.

Failure to maintain overlap may cause overheating and fire.

- Vent termination must not be recessed in the wall. Siding may be brought to the edge of the cap base.
- Flash and seal as appropriate for siding material at outside edges of cap.
- When installing a horizontal termination cap, follow the cap location guidelines as prescribed by current **ANSI Z223.1** and **CAN/CGA-B149** installation codes and refer to Section 6 of this manual.

CAUTION! Risk of Burns! Local codes may require installation of a cap shield to prevent anything or anyone from touching the hot cap.

NOTICE: For certain exposures which require superior resistance to wind-driven rain penetration, a flashing kit and HRC caps are available. When penetrating a brick wall, a brick extension kit is available for framing the brick.

Note: When using termination caps with factory-supplied heat shield attached, no additional wall shield firestop is required on the exterior side of a combustible wall.

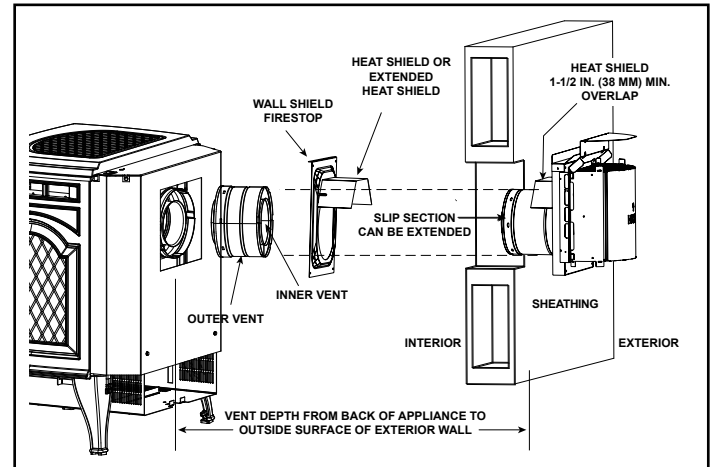

Figure 7.17 Venting through the wall

8 Electrical Information

A. General Information

WARNING! Risk of Shock or Explosion! DO NOT wire 110-120 VAC to the valve or to the appliance wall switch. Incorrect wiring will damage controls.

NOTICE: This appliance must be electrically wired and grounded in accordance with local codes or, in the absence of local codes, with **National Electric Code ANSI/NFPA 70-latest edition** or the **Canadian Electric Code CSA C22.1**.

- Plug the cord from the appliance junction box to unswitched 110-120 VAC. This is required for proper operation of the appliance.
- A 110-120 VAC circuit for this product must be protected with ground-fault circuit-interrupter protection, in compliance with the applicable electrical codes, when it is installed in locations such as in bathrooms or near sinks.
- Low voltage and 110-120 VAC voltage cannot be shared within the same wall box.

WARNING! Risk of Shock! Plug 3-pronged (grounding) plug directly into a properly grounded 3-pronged receptacle. DO NOT cut or remove grounding prong from plug.

Accessories Requirements

- This appliance may be used with a wall switch, wall mounted thermostat and/or a remote control.

Wiring for optional Hearth & Home Technologies approved accessories should be done now to avoid reconstruction. Follow instructions that come with those accessories.

Electrical Service and Repair

WARNING! Risk of Shock! Label all wires prior to disconnection when servicing controls. Wiring errors can cause improper and dangerous operation. Verify proper operation after servicing.

WARNING! Risk of Shock! Replace damaged wire with type 105° C rated wire. Wire must have high temperature insulation.

B. Wiring Requirements

Intellifire Plus Ignition System Wiring

- Plug the cord from the appliance junction box to 110-120 VAC for proper operation of the appliance.

WARNING! Risk of Shock or Explosion! DO NOT wire IPI controlled appliance junction box to a switched circuit. Incorrect wiring will override IPI safety lockout.

- Refer to Figure 8.1, IPI Wiring Diagram.
- This appliance is equipped with an IntelliFire Plus™ control valve which operates on a 6 volt/1.5 AMP system.
- Plug the 6 volt transformer plug into the appliance junction box to supply power to the unit OR install 4 AA cell batteries (not included) into the battery pack before use.

NOTICE: Batteries should only be used as a power source in the event of an emergency power outage. Batteries should not be used as a primary long-term power source. Battery polarity must be correct when installing batteries.

Do not store batteries in the battery pack when the appliance is powered by the 6 volt transformer connected to permanent electrical service.

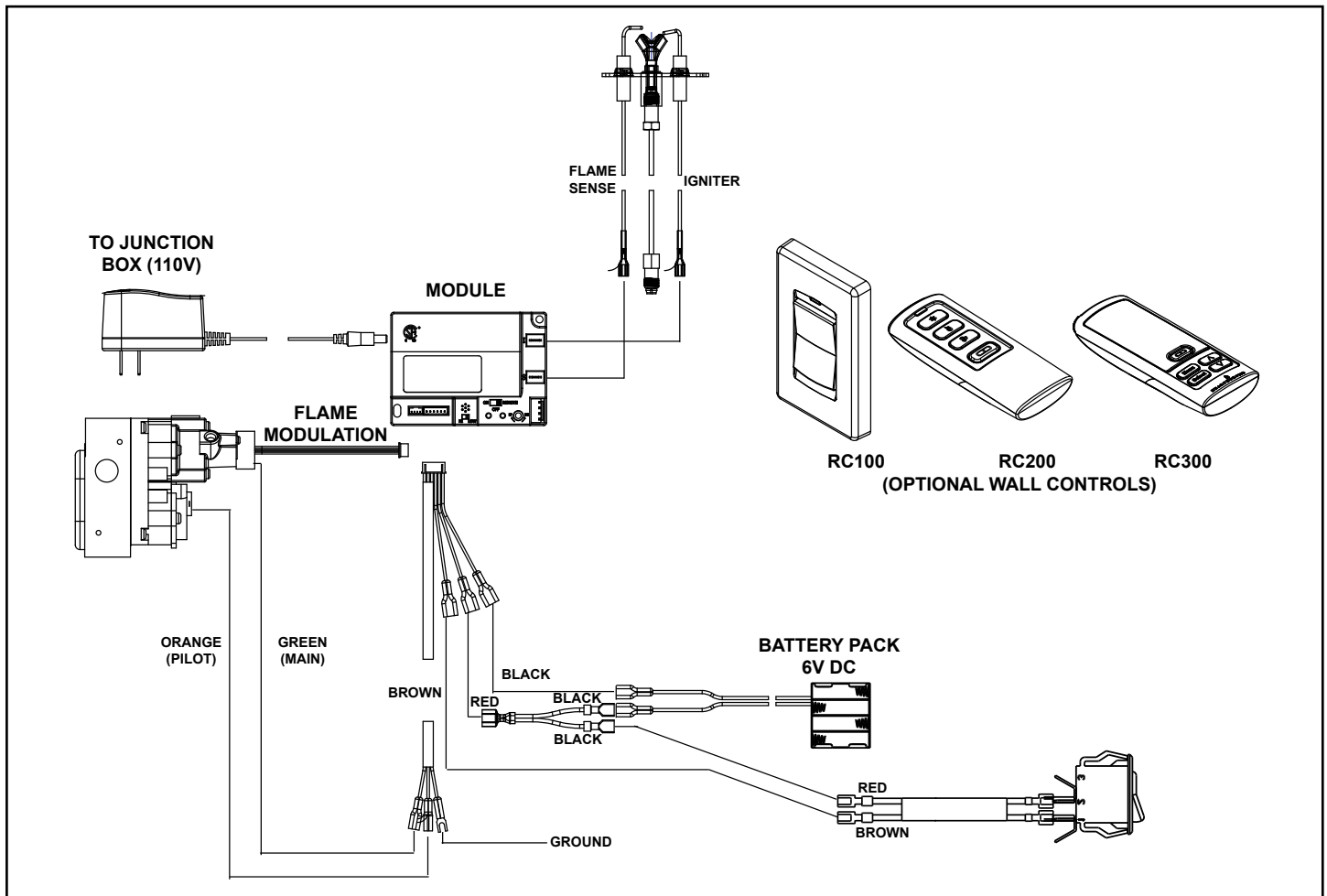

Figure 8.1 IPI Wiring Diagram

Wall Switch Installation for Fan (Optional)

If the box is being wired to a wall mounted switch for use with a fan (See Figure 8.2):

- The power supply for the appliance must be brought into a switch box.
- The power can then be supplied from the switch box to the appliance using a minimum of 14-3 with ground wire.
- At the switch box connect the black (hot) wire and red (switch leg) wire to the wall switch as shown.
- At the appliance connect the black (hot), white (neutral) and green (ground) wires to the junction box as shown.
- Add a 1/4 in. insulated female connector to the red (switch leg) wire, route it through the knockout in the face of the junction box, and connect to the top fan switch connector (1/4 in. male) as shown.

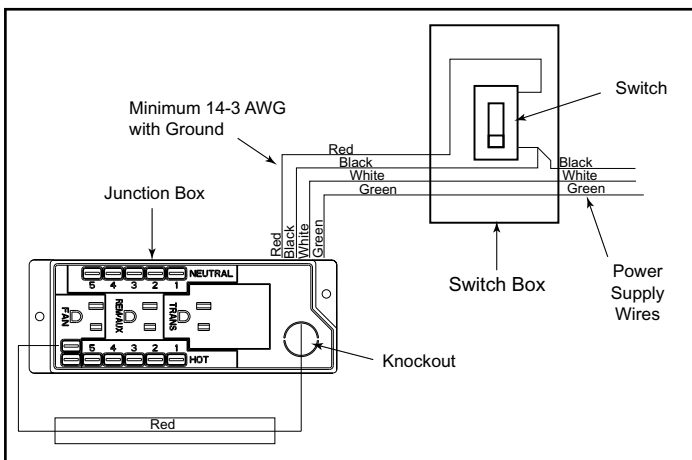

Figure 8.2 Junction Box Wired to Wall Switch or BC10

Optional Fan Installation

KIT CONTENTS:

- 1 - Blower Mounted in Housing
- 2 - Speed Control Knob
- 3 - Pal Nut
- 4 - Ceramic Snap Disk
- 5 - Speed Control (Rheostat)
- 6 - Wire Harness (attached to Blower)
- 7 - 12 Screws
- 8 - 12 inch Glass Tape
- 9 - 1 Zip Tie
- 10 - Bracket #1
- 11 - Thermostat Bracket

TOOLS REQUIRED: Short #2 Philips screwdriver; 11/16 in. wrench, 3/8 in. wrench.

Installation

1. Open and inspect contents of the blower kit. The contents of the kit are listed above and shown below in Figure 8.3. If any of the parts are missing or damaged, please contact your dealer for replacements.

NOTE: Not all parts will be used for this install.

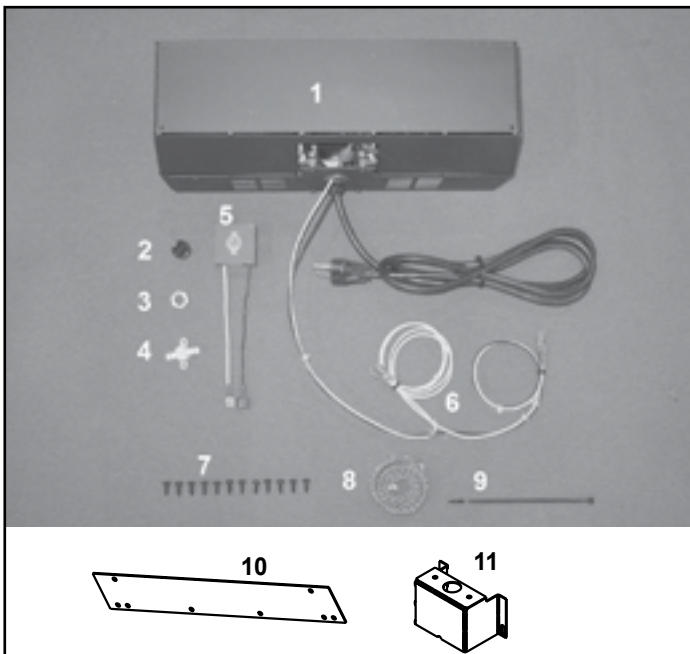

Figure 8.3 Fan Kit Contents

2. Lift off the appliance top and place it on a flat surface, with the porcelain side up to prevent damage. Remove the back shield by removing the two screws along the top of the shield. See Figure 8.4. Place the blower on the floor behind the appliance and route the ends of the wiring harness through the rubber grommet on the underside.
3. Holding the blower in place, attach it to the appliance with four of the screws provided. See Figure 8.5.

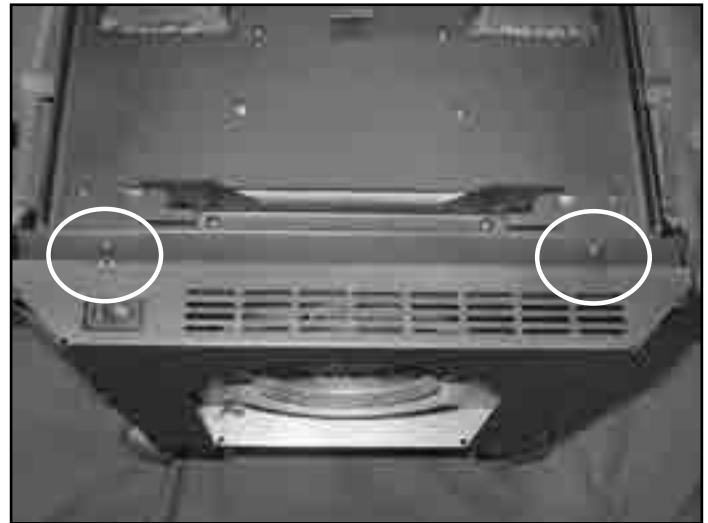

Figure 8.4 Remove Back Shield

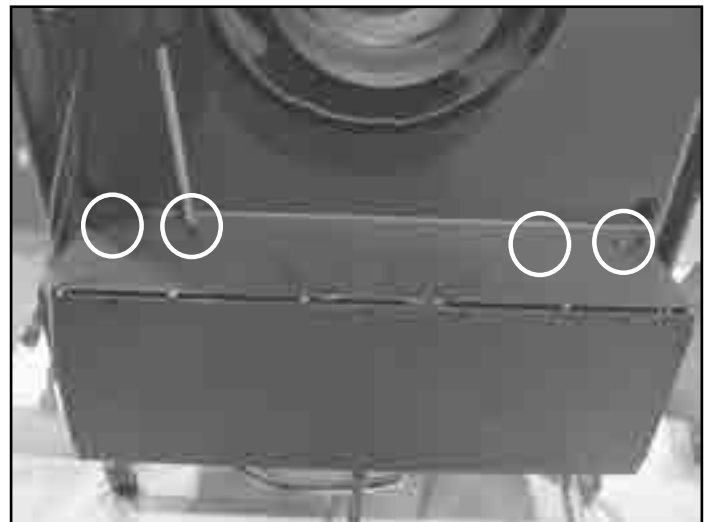

Figure 8.5 Attach Blower with Four Screws

4. Install the snap disc. A snap disc bracket is located in the appliance's component bag. Bend the two spade terminals on the snap disc from a horizontal to a vertical position. Insert the snap disc through the hole in the snap disc bracket and attach the two white wires from the wiring harness to the snap disc. See Figure 8.6.

NOTE: The mounting flange is on top of the bracket.

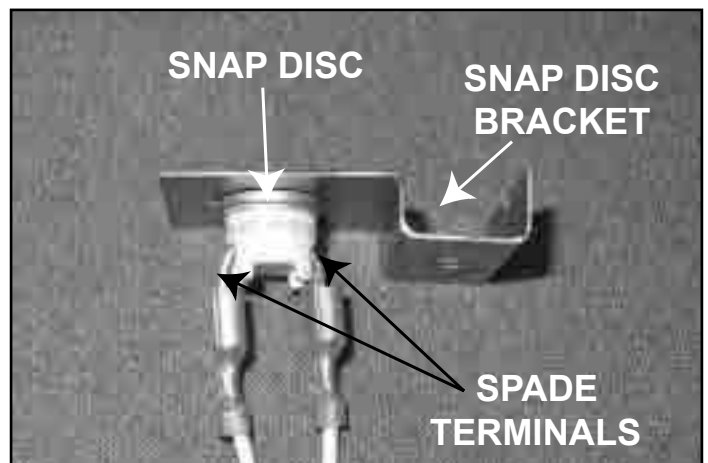

Figure 8.6 Install Snap Disc

- Attach the snap disc bracket to the stud located under the left side of the appliance using the 10-32 nut also located in the appliance component bag. Tighten until snug using the 3/8 in. wrench. See Figure 8.7 and Figure 8.8.

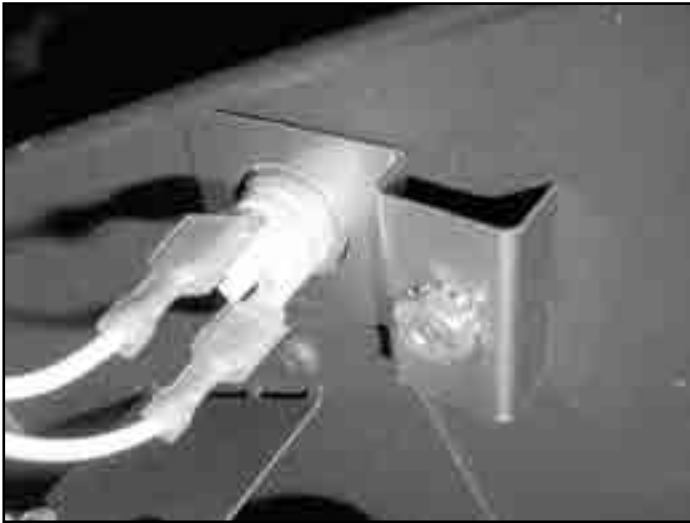

Figure 8.7 Attach Snap Disc Bracket



Figure 8.8 Mount Speed Control Using Pal Nut

- Install the speed control (rheostat). The speed control mounts to the right rear corner of the component tray. Insert the stem of the speed control through the hole located on the right side of the cover. Secure with the pal nut using an 11/16 in. (17.5 mm) wrench. Attach the black and white wires routed under the appliance indicated in Figure 8.9 (wiring diagram), to the variable speed switch wires. Use the blue jumper wire provided in the appliance component bag to make the connection on junction box terminals as shown in Figure 8.9. Push the speed control knob onto the stem. Secure any extra wire up and out of the way using the zip tie provided.
- Plug the fan into the receptacle labeled "FAN" on the junction box. See Figure 8.9. The blower will not run until the appliance has heated up enough to activate the snap disc. This can take up to 15 minutes depending on the temperature of the room. Likewise, the blower will not automatically turn off until the appliance has cooled off enough to turn off the snap disc.

Turning the control knob to the left (counterclockwise) until you hear an audible click will turn the blower "OFF". Turning the control knob to the right (clockwise) until you hear a click will turn the blower "ON". Turning the control knob further to the right will reduce the speed of the blower.

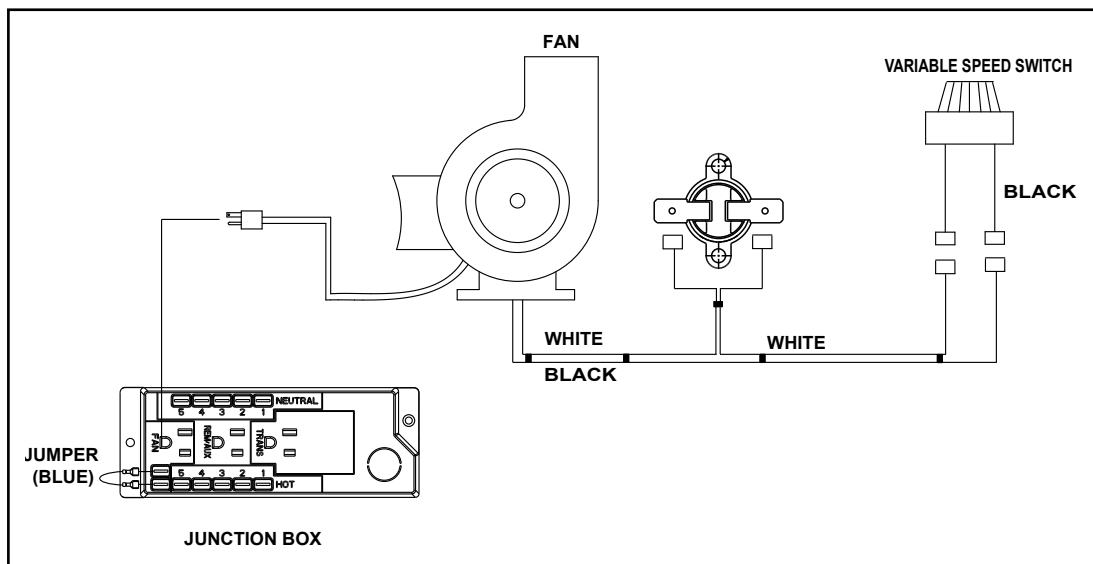

Figure 8.9 Fan Wiring Diagram

9 Gas Information

A. Fuel Conversion

- Make sure the appliance is compatible with available gas types.
- Conversions must be made by a qualified service technician using Hearth & Home Technologies specified and approved parts.



B. Gas Pressure

- Optimum appliance performance requires proper input pressures.
- Gas line sizing requirements will be determined in ANSI Z223.1 National Fuel Gas Code in the USA and CAN/CGA B149 in Canada.
- Pressure requirements are:

Gas Pressure	Natural Gas	Propane
Minimum inlet pressure	5.0 in. w.c.	11.0 in. w.c.
Maximum inlet pressure	10.0 in. w.c.	13.0 in. w.c.
Manifold pressure	3.5 in. w.c.	10.0 in. w.c.

WARNING! Risk of Fire or Explosion! High pressure will damage valve. Low pressure may cause explosion.

- Verify inlet pressures. Verify minimum pressures when other household gas appliances are operating.
- Install regulator upstream of valve if line pressure is greater than 1/2 psig.

 WARNING	
	Fire Risk. Explosion Hazard. High pressure will damage valve.
	<ul style="list-style-type: none">• Disconnect gas supply piping BEFORE pressure testing gas line at test pressures above 1/2 psig.• Close the manual shutoff valve BEFORE pressure testing gas line at test pressures equal to or less than 1/2 psig.

Note: Have the gas supply line installed in accordance with local codes, if any. If not, follow ANSI 223.1. Installation should be done by a qualified installer approved and/or licensed as required by the locality. (In the Commonwealth of Massachusetts installation must be performed by a licensed plumber or gas fitter).

Note: A listed (and Commonwealth of Massachusetts approved) 1/2 in. (13 mm) T-handle manual shut-off valve and flexible gas connector are connected to the 1/2 in. (13 mm) control valve inlet.

- **If substituting for these components, please consult local codes for compliance.**

C. Gas Connection

- Refer to Reference Section 3 for location of gas line access in appliance.
- Ensure that gas line does not come in contact with outer wrap of the appliance. Follow local codes.
- Connect incoming gas line to the 1/2 in. (13 mm) connection on manual shutoff valve.

WARNING! Risk of Fire or Explosion! Support control when attaching pipe to prevent bending gas line.

- A small amount of air will be in the gas supply lines.

WARNING! Risk of Fire or Explosion! Gas build-up during line purge could ignite.

- Purge should be performed by qualified service technician.
- Ensure adequate ventilation.
- Ensure there are no ignition sources such as sparks or open flames.

Light the appliance. It will take a short time for air to purge from lines. When purging is complete the appliance will light and operate normally.

WARNING! Risk of Fire, Explosion or Asphyxiation! Check all fittings and connections with a non-corrosive commercially available leak-check solution. **DO NOT** use open flame. Fittings and connections could have loosened during shipping and handling.

WARNING! Risk of Fire! **DO NOT** change valve settings. This valve has been preset at the factory.

D. High Altitude Installations

NOTICE: If the heating value of the gas has been reduced, these rules do not apply. Check with your local gas utility or authorities having jurisdiction.

When installing above 2000 feet elevation:

- In the USA: Reduce input rate 4% for each 1000 feet above 2000 feet.
- In CANADA: Input ratings are certified without a reduction of input rate for elevations up to 4500 feet (1370 m) above sea level. Please consult provincial and/or local authorities having jurisdiction for installations at elevations above 4500 feet (1370 m).

Check with your local gas utility to determine proper orifice size.

E. Air Shutter Setting

Air shutter settings should be adjusted by a qualified service technician at the time of installation. The air shutter is set fully open at the factory for minimum vertical vent run. Adjust air shutter for longer vertical runs. See Figure 9.1.

- Loosen the wing nuts.
- Slide the wing nut to the right to close the air shutter.
- Slide the wing nut to the left to open the air shutter.
- Tighten the wing nuts.

NOTICE: *If sooting occurs, provide more air by opening the air shutter.*

WING NUTS FOR SHUTTER ADJUSTMENT

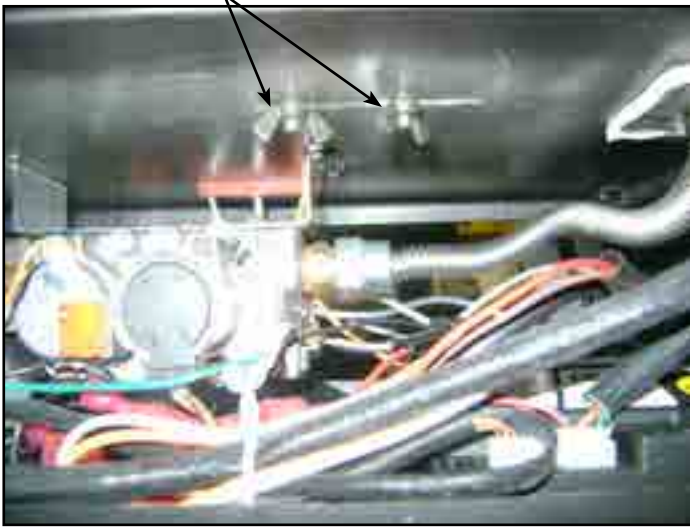

Figure 9.1 Air Shutter

10 Appliance Setup

A. Remove Fixed Glass Assembly

WARNING! Risk of Asphyxiation! Handle fixed glass assembly with care. Inspect the gasket to ensure it is undamaged and inspect the glass for cracks, chips or scratches.

- **DO NOT** strike, slam or scratch glass.
 - **DO NOT** operate fireplace with glass removed, cracked, broken or scratched.
 - Replace as a complete assembly.
1. Remove front casting by grasping it at the top and lifting up. If the stove is already installed in a top vented configuration, the top casting will need to be lifted slightly to accommodate removal of the front casting. See Figure 10.1. Set front casting aside on prepared work surface.
 2. Using a Phillips screwdriver, remove the three screws on the front glass assembly and take the glass off the appliance. See Figure 10.2.

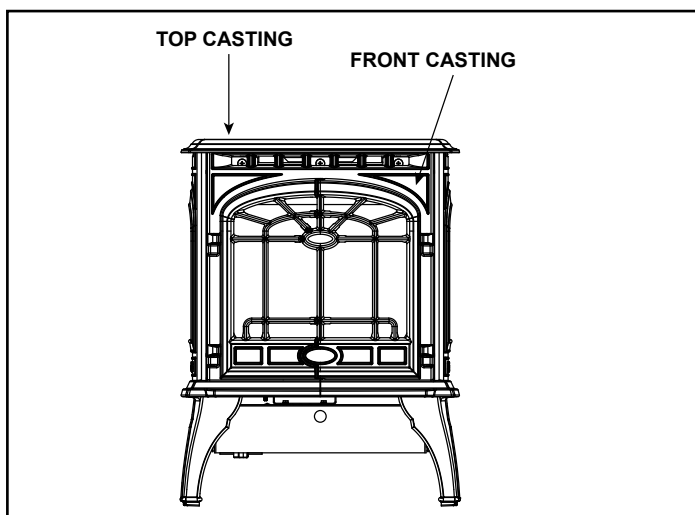

Figure 10.1 Remove Casting

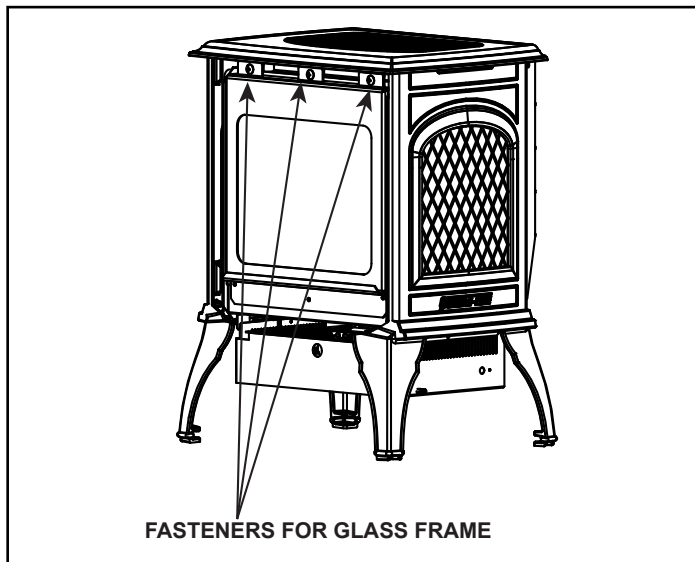

Figure 10.2 Remove Glass Frame

B. Remove the Shipping Materials

Remove shipping materials from inside or underneath the firebox.

C. Clean the Appliance

Clean/vacuum any sawdust that may have accumulated inside the firebox or underneath in the control cavity.

D. Install the Log Assembly

LOG PLACEMENT INSTRUCTIONS

Log Set Assembly: LOGS-GARNET

CAUTION: Logs are fragile, handle with care. **Log #1 (7016-172):** Gently remove top of unit and set aside. Remove cast face by sliding straight up and set aside. Remove the glass by removing the three Phillips head fasteners at the top of the glass frame assembly. Lean glass frame forward and lift out. Place the notch in the Rear Log over the pilot assembly. Push the log all the way to the rear of the firebox and center the log from left to right. See Figure 10.3.



Figure 10.3.

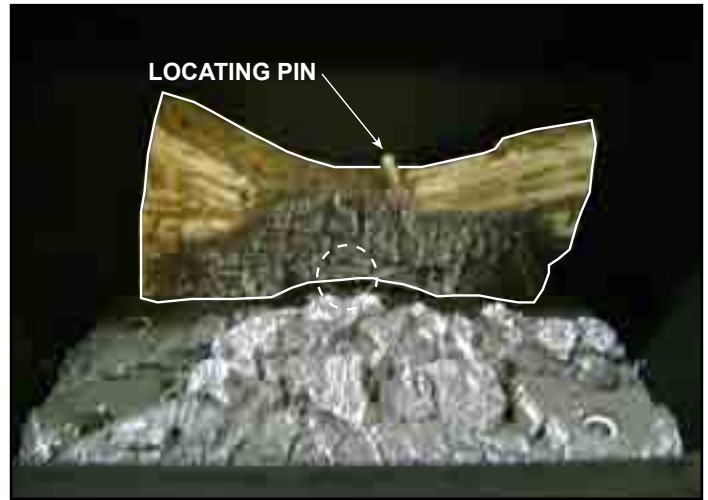

Figure 10.4

Log #2 (7016-171): Align hole on bottom of Log #2 with locating pin on Log #1. Position bottom of Log #2 into notch on left front of burner. See Figure 10.4.

Log #3 (7016-170): Align hole on bottom of Log #3 with locating pin on Log #2. Position bottom of Log #3 into the notch on the right front of burner. See Figure 10.5.

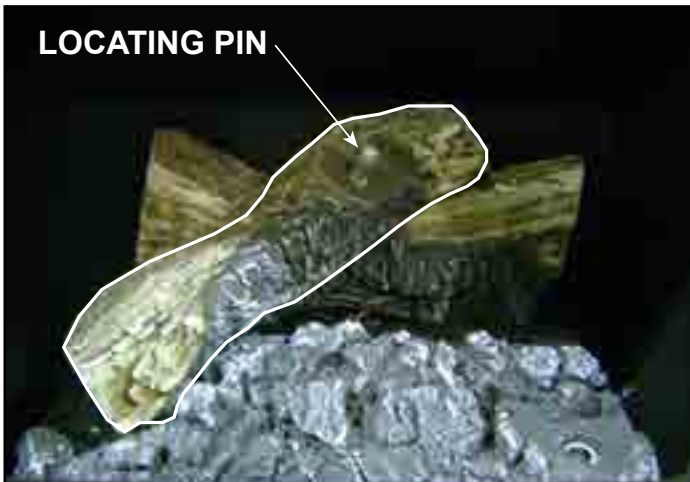

Figure 10.4



Figure 10.5

E. Install Fixed Glass Assembly

WARNING! Risk of Asphyxiation! Handle fixed glass assembly with care. Inspect the gasket to ensure it is undamaged and inspect the glass for cracks, chips or scratches.

- **DO NOT** strike, slam or scratch glass.
- **DO NOT** operate fireplace with glass removed, cracked, broken or scratched.
- Replace as a complete assembly.

Reinstall the glass frame by engaging the latches at the bottom corners of the firebox with the glass frame tabs. See Figure 10.1 and 10.2 for reference. Reinstall front casting.

11 Reference Materials

A. Vent Components Diagrams

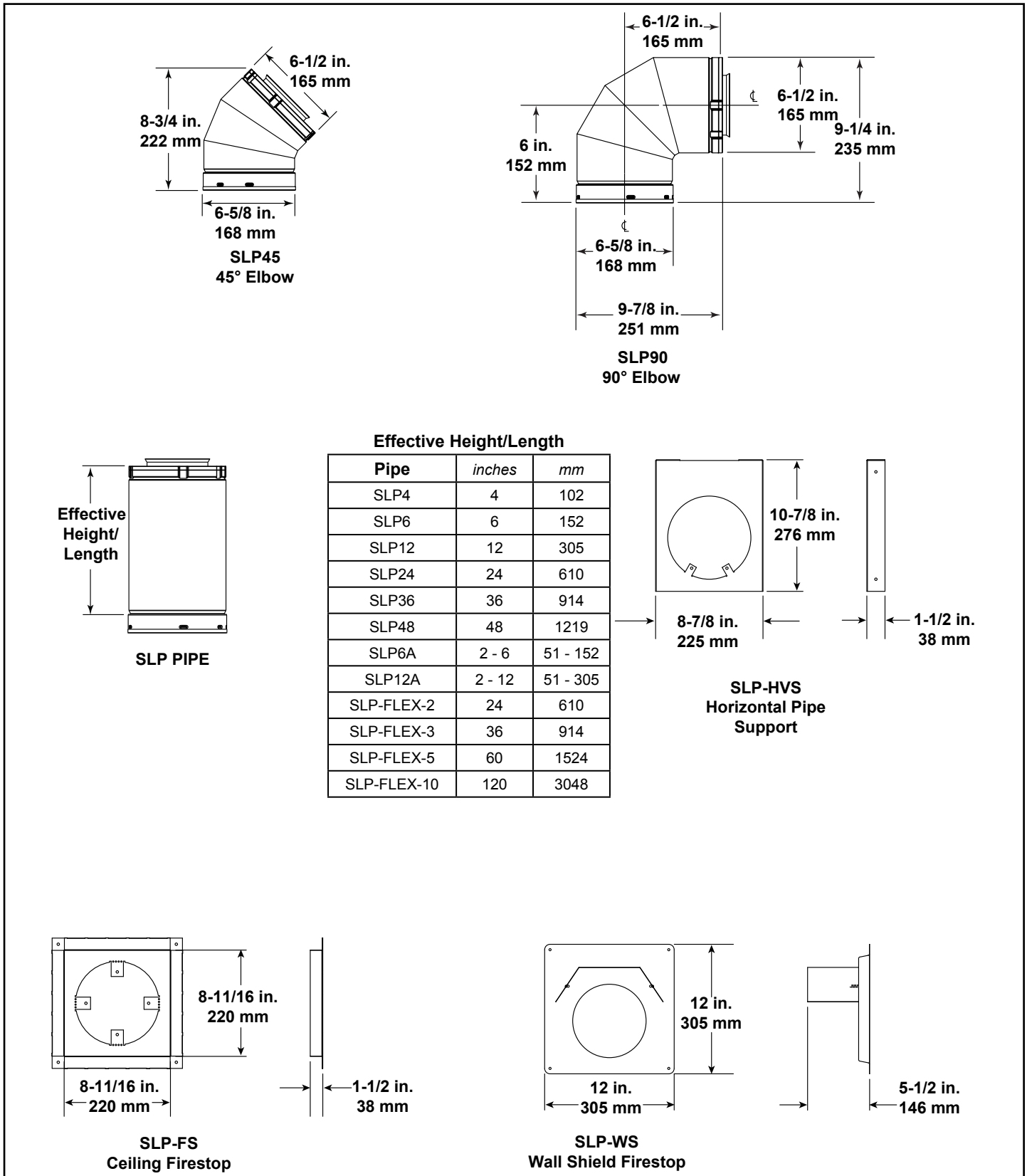
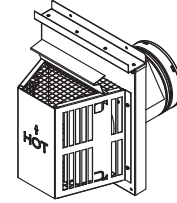
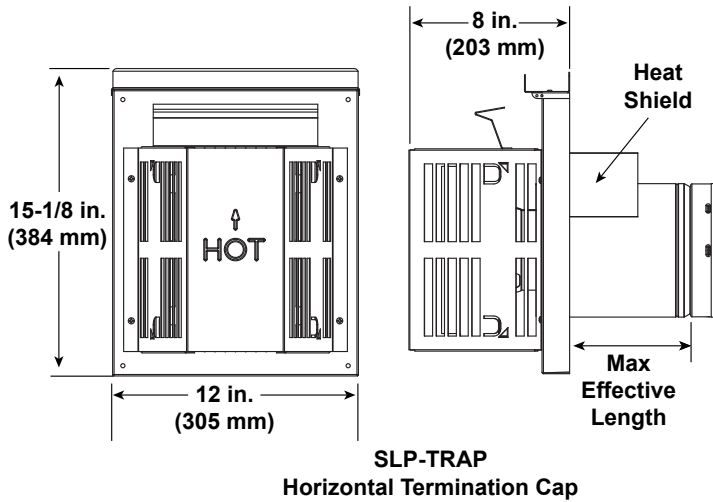

Figure 11.1 SLP Series Vent Components

A. Vent Components Diagrams (continued)

Note: Heat shields MUST overlap by a minimum of 1-1/2 in. (38 mm). The heat shield is designed to be used on a wall 4 in. to 7-1/4 in. (102 mm to 184 mm) thick. If wall thickness is less than 4 in. (102 mm) the existing heat shields must be field trimmed. If wall thickness is greater than 7-1/4 in. (184 mm) a DVP-HSM-B will be required.



Term Cap	Minimum Effective Length	Maximum Effective Length
Trap1	3-1/8 in.	4-3/4 in.
	79 mm	121 mm
Trap2	5-1/4 in.	9-1/4 in.
	133 mm	235 mm

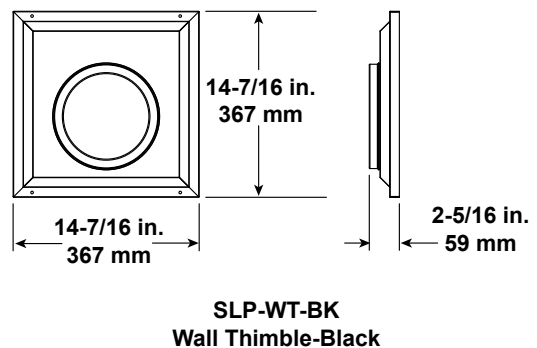
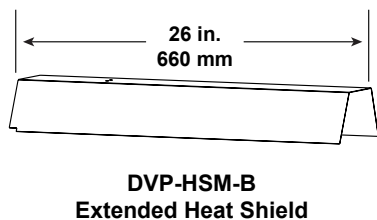
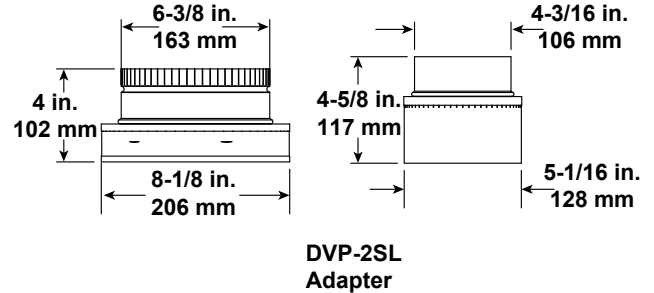
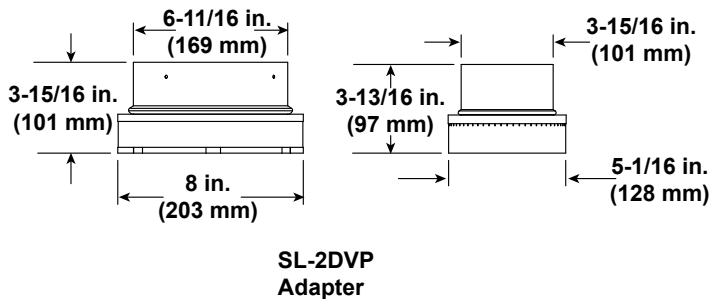

Figure 11.2 SLP Series Vent Components

→ A. Vent Components Diagrams (continued)

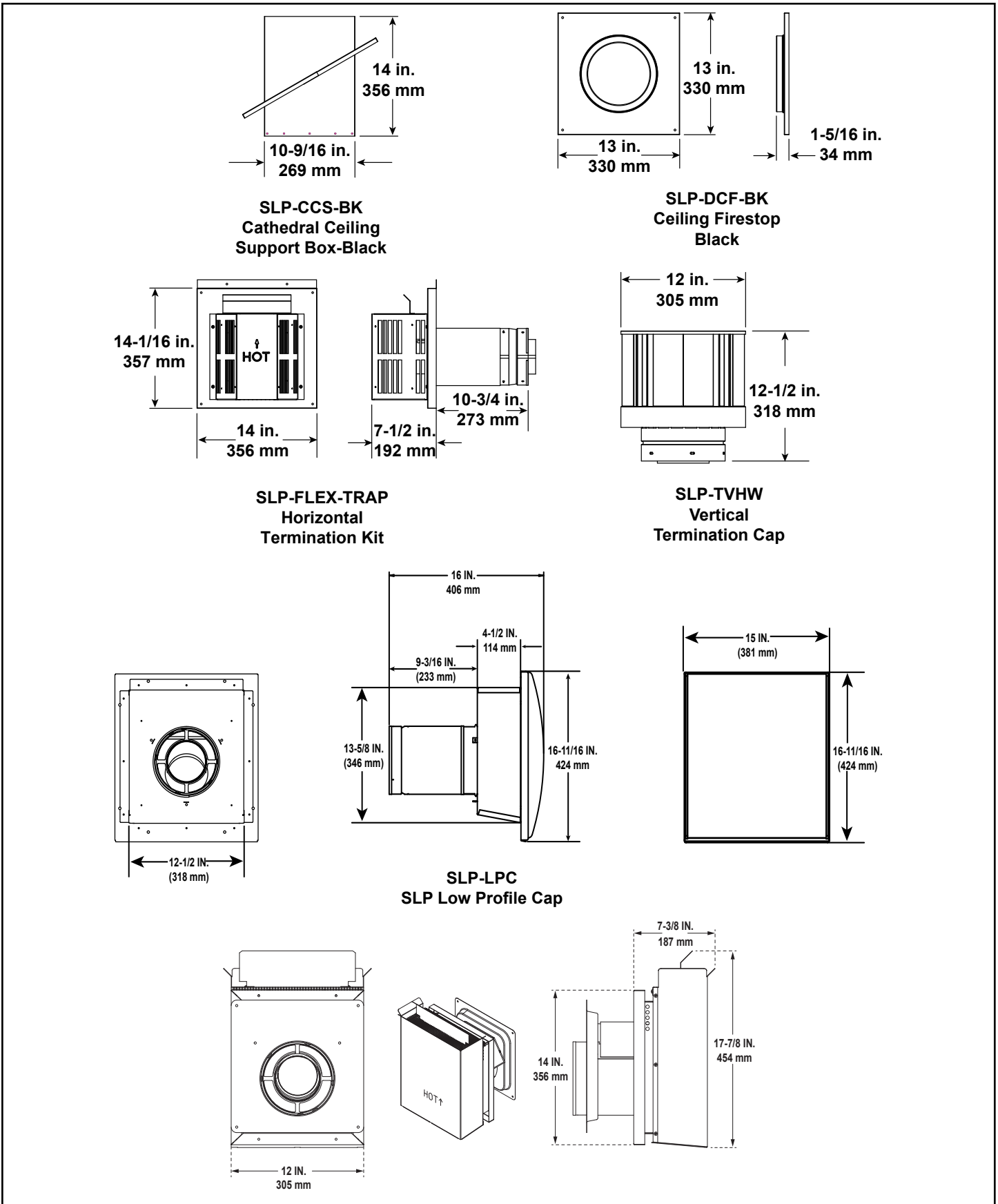
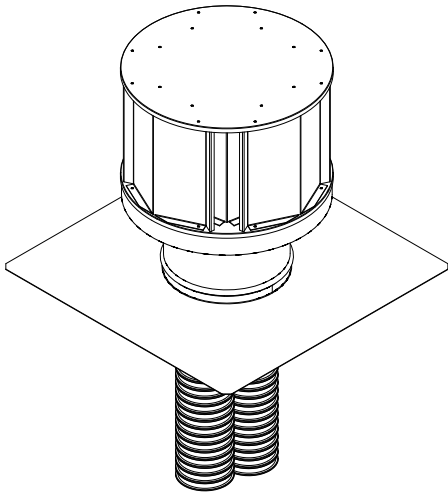

Figure 11.3 SLP Series Vent Components

A. Vent Components Diagrams (continued)

COAXIAL to COLINEAR VENTING



LINK-DV30B
Flex Liner Kit



768-380A
Stainless Steel Flex Pipe

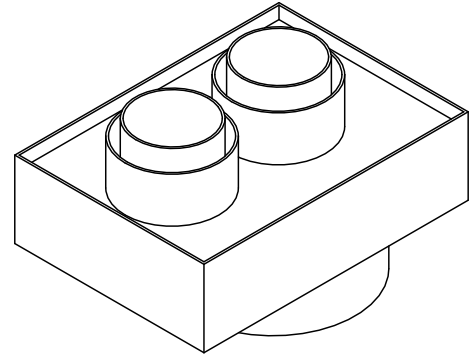

DV-46DVA-GCL
Coaxial/Colinear Appliance Connector

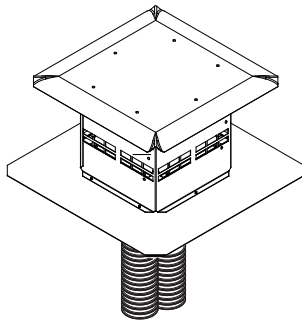

LINKSQC-DV30 (COPPER)
LINKSQB-DV30 (BLACK)

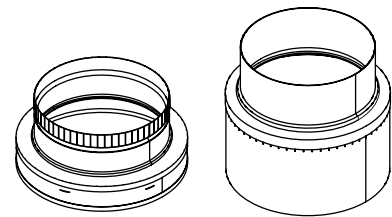

DVP-2SL
Adapter

Figure 11.4 SLP Series Vent Components

B. Accessories

Install approved accessories per instructions included with accessories. Contact your dealer for a list of approved accessories.

WARNING! Risk of Fire and Electric Shock! Use ONLY Hearth & Home Technologies-approved optional accessories with this appliance. Using non-listed accessories could result in a safety hazard and will void the warranty.

Remote Controls, Wall Controls and Wall

Switches

Follow the instructions supplied with the control installed to operate your fireplace:

For safety:

- Install a switch lock or a wall/remote control with child protection lockout feature.
- Keep remote controls out of reach of children.

See your dealer if you have questions.

Fan

Follow the instructions supplied with the fan kit to operate your fan. See your dealer if you have questions.

Refractory

Follow the instructions supplied with the refractory. See your dealer if you have questions.

Quadra-Fire, a brand of Hearth & Home Technologies
352 Mountain Huse Road, Halifax, PA 17032
www.quadrafire.com

Please contact your Quadra-Fire dealer with any questions or concerns.

For the location of your nearest Quadra-Fire dealer, please visit www.quadrafire.com.

Printed in U.S.A. - Copyright 2014