

# Owner's Manual

## Care and Operation

**INSTALLER:** Leave this manual with party responsible for use and operation.

**OWNER:** Retain this manual for future reference.

Contact your dealer with questions regarding installation, operation or service.

**NOTICE: DO NOT** discard this manual!

# QUADRA-FIRE®

### Models:

TOPAZ-MBK-IPI  
TOPAZD-PMH-IPI  
TOPAZD-MBK-IPI  
TOPAZD-CSB-IPI

**GAS-FIRED**

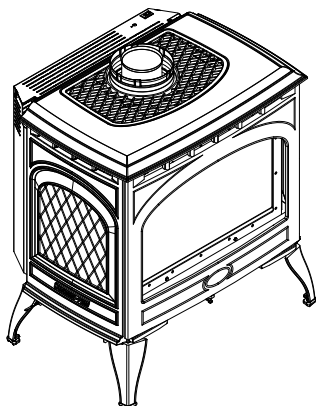

**Solitaire**

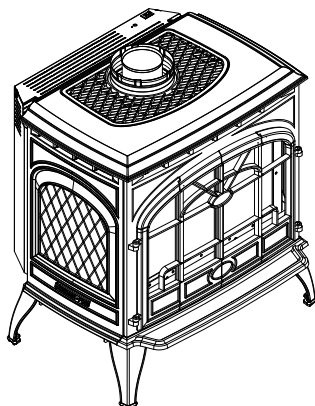

**Cabinet Style**

This appliance may be installed as an OEM installation in manufactured home (USA only) or mobile home and must be installed in accordance with the manufacturer's instructions and the manufactured home construction and safety standard, *Title 24 CFR, Part 3280* or *Standard for Installation in Mobile Homes, CAN/CSA Z240MH, in Canada*.

*This appliance is only for use with the type(s) of gas indicated on the rating plate.*

Installation and service of this appliance should be performed by qualified personnel. Hearth & Home Technologies recommends HHT Factory Trained or NFI certified professionals.



**⚠ WARNING:** If the information in these instructions is not followed exactly, a fire or explosion may result causing property damage, personal injury, or death.

- **DO NOT** store or use gasoline or other flammable vapors and liquids in the vicinity of this or any other appliance.
- **What to do if you smell gas**
  - **DO NOT** try to light any appliance.
  - **DO NOT** touch any electrical switch; do not use any phone in your building.
  - Immediately call your gas supplier from a neighbor's phone. Follow the gas supplier's instructions.
  - If you cannot reach your gas supplier, call the fire department.
- Installation and service must be performed by a qualified installer, service agency, or the gas supplier.

# ! DANGER



**HOT GLASS WILL CAUSE BURNS.**

**DO NOT TOUCH GLASS UNTIL COOLED.**

**NEVER ALLOW CHILDREN TO TOUCH GLASS.**

A barrier designed to reduce the risk of burns from the hot viewing glass is provided with this appliance and shall be installed for the protection of the children and other at-risk individuals.

In the Commonwealth of Massachusetts installation must be performed by a licensed plumber or gas fitter.

See Table of Contents for location of additional Commonwealth of Massachusetts requirements.

# 1 Welcome

Read this manual before operating this appliance.  
Please retain this Owner's Manual for future reference.

Read the Installation Manual before making any installation or finishing changes.

## A. Congratulations

Congratulations on selecting a Quadra-Fire gas stove, an elegant and clean alternative to wood burning stoves. The Quadra-Fire gas stove you have selected is designed to provide the utmost in safety, reliability, and efficiency.

As the owner of a new stove, you'll want to read and carefully follow all of the instructions contained in this owner's manual. Pay special attention to all cautions and warnings.

This owner's manual should be retained for future reference. We suggest that you keep it with your other important documents and product manuals.

The information contained in this owner's manual, unless noted otherwise, applies to all models and gas control systems.

Your new Quadra-Fire gas stove will give you years of durable use and trouble-free enjoyment. Welcome to the Quadra-Fire family of stove products!

### Local Dealer Information

**DEALER:** Fill in your name, address, phone and email information here and appliance information below.

Dealer Name: \_\_\_\_\_  
 Address: \_\_\_\_\_  
 \_\_\_\_\_  
 Phone: \_\_\_\_\_  
 Email: \_\_\_\_\_

#### Appliance Information:

Brand: \_\_\_\_\_ Model Name: \_\_\_\_\_  
 Serial Number: \_\_\_\_\_ Date Installed: \_\_\_\_\_

**Listing Label Information/Location** The model information regarding your specific stove can be found on the rating plate usually located in the control area of the stove.

**Model Name** points to: **Model/(Modèle): TOPAZ-IPI**

**Serial Number** points to: **Serial No. HF**

**Gas and Electric Information** points to the bottom left section containing electrical requirements.

**Type of Gas** points to the **NATURAL GAS** section.

The label includes the following information:

- QUADRA-FIRE** NOTHING BURNS LIKE A QUADRA
- Model/(Modèle): TOPAZ-IPI**
- Serial No. HF**
- Barcode Label**
- Quadra-Fire** a brand of Hearth & Home Technologies, 352 Mountain House Road Halifax
- VENTED GAS FIREPLACE HEATER MH61818**
- ANSI Z21.88-2014 • CSA 2.33-2014**
- CAN/CSA - P.4.1-15 • FE 69.7% NG / 68.9% LP**
- Type of Gas (SorteDeGaz): NATURAL GAS**
- Vented gas fireplace heater - Not for use with solid fuel.**
- Appareil de chauffage de foyer avec conduit d'évacuation des gaz - n'utilisez pas avec des combustibles solides.**
- OWNER'S MANUAL** and **INSTALLATION MANUAL** QR codes
- Minimum Permissible Gas Supply for Purposes of Input Adjustment:**
  - Approved Minimum (De Gaz) Acceptable: 5.0 in. w.c. (Po. Col. d'eau)
  - Maximum Pressure (Pression): 10.0 in. w.c. (Po. Col. d'eau)
  - Maximum Manifold Pressure (Pression): 3.5 in. w.c. (Po. Col. d'eau)
  - Minimum Manifold Pressure (Pression): 1.7 in. w.c. (Po. Col. d'eau)
  - Minimum rate with variable regulator on control valve
  - Total Electrical Requirements: 120Vac, 60Hz, less than 12 Amperes
- USA** and **CANADA** specifications:
 

ALTITUDE:	0-2000 FT	0-4500 FT
MAX. INPUT BTU/h	37,000	37,000
MIN. INPUT BTU/h	26,000	26,000
ORIFICE SIZE:	#32 DMS	#32 DMS
- MADE IN USA**
- Date of Manufacture / Date de fabrication** (2018-2020)
- Manufactured by/Fabriqué par: Hearth and Home Technologies**
- Energy Verified / Rendement Énergétique Vérifié** and **UL LISTED MH61818** logos
- 2341-990\_R7

## ▲ Safety Alert Key:

- **DANGER!** Indicates a hazardous situation which, if not avoided will result in death or serious injury.
- **WARNING!** Indicates a hazardous situation which, if not avoided could result in death or serious injury.
- **CAUTION!** Indicates a hazardous situation which, if not avoided, could result in minor or moderate injury.
- **NOTICE:** Used to address practices not related to personal injury.

# Table of Contents

## 1 Welcome

- A. Congratulations . . . . . 2
- B. Limited Lifetime Warranty. . . . . 4

## 2 Product Specific Information

- A. Appliance Certification . . . . . 7
- B. Glass Specifications (Ceramic) . . . . . 7
- C. BTU Specifications. . . . . 7

## 3 Important Safety and Operating Information

- A. Appliance Safety . . . . . 8
- B. California Safety Warning. . . . . 8
- C. General Operating Parts . . . . . 9
- D. Fuel Specifications. . . . . 9
- E. Before Lighting Appliance. . . . . 9
- F. Lighting Instructions (IPI) . . . . . 10
- G. Appliance Break-In. . . . . 11
- H. Heat Management . . . . . 11
- I. Operation During A Power Outage (IPI Plus) . . . . . 12
- J. Detailed Component Operating Instructions
  - IntelliFire Plus . . . . . 13

## 4 Maintenance and Service

- A. Maintenance: Frequency and Tasks. . . . . 14
- B. Maintenance Tasks - Homeowner . . . . . 14
- C. Maintenance Tasks - Qualified Service Technician . . . . . 16

## 5 Frequently Asked Questions and Troubleshooting

- A. Frequently Asked Questions . . . . . 17
- B. Troubleshooting . . . . . 18

## 6 Reference Materials

- A. Accessories . . . . . 20
- B. Service Parts List . . . . . 21
- B. Contact Information . . . . . 28

➔ = Contains updated information.

## B. Limited Lifetime Warranty

### Hearth & Home Technologies LIMITED LIFETIME WARRANTY

Hearth & Home Technologies, on behalf of its hearth brands (“HHT”), extends the following warranty for HHT gas, wood, pellet and electric hearth appliances that are purchased from an HHT authorized dealer.

#### **WARRANTY COVERAGE:**

HHT warrants to the original owner of the HHT appliance at the site of installation, and to any transferee taking ownership of the appliance at the site of installation within two years following the date of original purchase, that the HHT appliance will be free from defects in materials and workmanship at the time of manufacture. After installation, if covered components manufactured by HHT are found to be defective in materials or workmanship during the applicable warranty period, HHT will, at its option, repair or replace the covered components. HHT, at its own discretion, may fully discharge all of its obligations under such warranties by replacing the product itself or refunding the verified purchase price of the product itself. The maximum amount recoverable under this warranty is limited to the purchase price of the product. This warranty is subject to conditions, exclusions and limitations as described below.

#### **WARRANTY PERIOD:**

Warranty coverage for consumers begins at the date of installation. In the case of new home construction, warranty coverage begins on the date of first occupancy of the dwelling or six months after the sale of the product by an independent, authorized HHT dealer/distributor, whichever occurs earlier. However, the warranty shall commence no later than 24 months following the date of product shipment from HHT, regardless of the installation or occupancy date. The warranty period for parts and labor for covered components is produced in the following table.

The term “Limited Lifetime” in the table below is defined as: 20 years from the beginning date of warranty coverage for gas appliances, and 10 years from the beginning date of warranty coverage for wood and pellet appliances. These time periods reflect the minimum expected useful lives of the designated components under normal operating conditions.

Warranty Period		HHT Manufactured Appliances and Venting					
Parts	Labor	Gas	Pellet	Wood	Electric	Venting	Components Covered
1 Year		X	X	X	X	x	All parts and material except as covered by Conditions, Exclusions, and Limitations listed
2 years			X	X			Igniters, auger motors, electronic components, and glass
		X	X	X			Factory-installed blowers
				X			Molded refractory panels
		X					Ignition Modules
3 years			X				Firepots, burnpots, mechanical feeders/auger assemblies
5 years	1 year	X					Vent Free burners, Vent Free ceramic fiber logs, Aluminized Burners
			X	X			Castings and Baffles
6 years	3 years			X			Catalyst - limitations listed
7 years	3 years		X	X			Manifold tubes, HHT chimney and termination
10 years	1 year	X					Burners, logs and refractory
Limited Lifetime	3 years	X	X	X			Firebox and heat exchanger, Grate and Stainless Steel Burners, FlexBurn® System (engine, inner cover, access cover and fireback)
90 Days		X	X	X	X	X	All replacement parts beyond warranty period

**WARRANTY CONDITIONS:**

- This warranty only covers HHT appliances that are purchased through an HHT authorized dealer or distributor. A list of HHT authorized dealers is available on the HHT branded websites.
- This warranty is only valid while the HHT appliance remains at the site of original installation.
- This warranty is only valid in the country in which the HHT authorized dealer or distributor that sold the appliance resides.
- Contact your installing dealer for warranty service. If the installing dealer or distributor is unable to provide necessary parts, contact the nearest HHT authorized dealer or supplier. Additional service fees may apply if you are seeking warranty service from a dealer other than the dealer from whom you originally purchased the product.
- Check with your dealer in advance for any costs to you when arranging a warranty call. Travel and shipping charges for parts are not covered by this warranty.
- Limited Catalyst Warranty
  - o For wood burning products containing a catalyst, the catalyst will be warranted for a six-year period as follows: if the original catalyst or a replacement catalyst proves defective or ceases to maintain 70% of its particulate emission reduction activity (as measured by an approved testing procedure) within 36 months from the purchase date, the catalyst will be replaced for free.
  - o From 37 to 72 months a pro-rated credit will be allowed against a replacement catalyst and labor credit necessary to install the replacement catalyst. The proration rate is as follows:

Amount of Time Since Purchase	Credit Towards Replacement Cost
0 - 36 Months	100%
37 - 48 Months	30%
49 - 60 Months	20%
61 - 72 Months	10%

- o Any replacement catalyst will be warranted under the terms of the catalyst warranty for the remaining term of the original warranty. The purchaser must provide the name, address, and telephone number of the location where the product is installed, proof of original purchase date, date of failure, and any relevant information regarding the failure of the catalyst.

**WARRANTY EXCLUSIONS:**

This warranty does not cover the following:

- Changes in surface finishes as a result of normal use. As a heating appliance, some changes in color of interior and exterior surface finishes may occur. This is not a flaw and is not covered under warranty.
- Damage to printed, plated, or enameled surfaces caused by fingerprints, accidents, misuse, scratches, melted items, or other external sources and residues left on the plated surfaces from the use of abrasive cleaners or polishes.
- Repair or replacement of parts that are subject to normal wear and tear during the warranty period are not covered. These parts include: paint, wood and pellet gaskets, firebricks, grates, flame guides, batteries and the discoloration of glass.
- Minor expansion, contraction, or movement of certain parts causing noise. These conditions are normal and complaints related to this noise are not covered by this warranty.
- Damages resulting from: (1) failure to install, operate, or maintain the appliance in accordance with the installation instructions, operating instructions, and listing agent identification label furnished with the appliance; (2) failure to install the appliance in accordance with local building codes; (3) shipping or improper handling; (4) improper operation, abuse, misuse, continued operation with damaged, corroded or failed components, accident, or improperly/incorrectly performed repairs (5) environmental conditions, inadequate ventilation, negative pressure, or drafting caused by tightly sealed constructions, insufficient make-up air supply, or handling devices such as exhaust fans or forced air furnaces or other such causes; (6) use of fuels other than those specified in the operation instructions; (7) installation or use of components not supplied with the appliance or any other components not expressly authorized and approved by HHT; (8) modification of the appliance not expressly authorized and approved by HHT in writing; and/or (9) interruptions or fluctuations of electrical power supply to the appliance.
- Non-HHT venting components, hearth connections or other accessories used in conjunction with the appliance.
- Any part of a pre-existing fireplace system in which an insert or a decorative gas appliance is installed.
- HHT's obligation under this warranty does not extend to the appliance's capability to heat the desired space. Information is provided to assist the consumer and the dealer in selecting the proper appliance for the application. Consideration must be given to the appliance location and configuration, environmental conditions, insulation and air tightness of the structure.

**This warranty is void if:**

- The appliance has been over-fired, operated in atmospheres contaminated by chlorine, fluorine, or other damaging chemicals. Over-firing can be identified by, but not limited to, warped plates or tubes, deformation/warping of interior cast iron structure or components, rust colored cast iron, bubbling, cracking and discoloration of steel or enamel finishes.
- The appliance is subjected to prolonged periods of dampness or condensation.
- There is any damage to the appliance or other components due to water or weather damage which is the result of, but not limited to, improper chimney or venting installation.

**LIMITATIONS OF LIABILITY**

- The owner's exclusive remedy and HHT's sole obligation under this warranty, under any other warranty, express or implied, or in contract, tort or otherwise, shall be limited to replacement, repair, or refund, as specified above. In no event will HHT be liable for any incidental or consequential damages caused by defects in the appliance. Some states do not allow exclusions or limitation of incidental or consequential damages, so these limitations may not apply to you. This warranty gives you specific rights; you may also have other rights, which vary from state to state. EXCEPT TO THE EXTENT PROVIDED BY LAW, HHT MAKES NO EXPRESS WARRANTIES OTHER THAN THE WARRANTY SPECIFIED HEREIN. THE DURATION OF ANY IMPLIED WARRANTY IS LIMITED TO DURATION OF THE EXPRESSED WARRANTY SPECIFIED ABOVE.

# 2 Product Specific Information

## A. Appliance Certification

**MODELS:** TOPAZ-MBK-IPI, TOPAZD-PMH-IPI, TOPAZD-MBK-IPI, TOPAZD-CSB-IPI

**LABORATORY:** Underwriters Laboratories, Inc. (UL)

**TYPE:** Direct Vent Heater

**STANDARD:** ANSI Z21.88-2017/CSA 2.33-2017

This product is listed to ANSI standards for “Vented Gas stove Heaters” and applicable sections of “Gas Burning Heating Appliances for Manufactured Homes and Recreational Vehicles”, and “Gas Fired Appliances for Use at High Altitudes”.

**NOTICE:** This installation must conform with local codes. In the absence of local codes you must comply with the National Fuel Gas Code, ANSI Z223.1-latest edition in the U.S.A. and the CAN/CGA B149 Installation Codes in Canada.

**NOT INTENDED FOR USE AS A PRIMARY HEAT SOURCE.**

This appliance is tested and approved as either supplemental room heat or as a decorative appliance. It should not be factored as primary heat in residential heating calculations.



Installation and service of this appliance should be performed by qualified personnel. Hearth & Home Technologies suggests NFI certified or factory trained professionals, or technicians supervised by an NFI certified professional ([www.nficertified.org](http://www.nficertified.org)).

## B. Glass Specifications (Ceramic)

This appliance is equipped with 5 mm ceramic glass. Replace glass only with 5 mm ceramic glass. Please contact your dealer for replacement glass.

## C. BTU Specifications



Models (U.S. or Canada)	Maximum Input BTU/h	Minimum Input BTU/h	Orifice Size (DMS)	AFUE	State Steady Efficiency %	P4 %
TOPAZ-MBK-IPI TOPAZD-PMH-IPI TOPAZD-MBK-IPI TOPAZD-CSB-IPI (Natural Gas)	(0-2000 FT) 37,000	26,000	32	68.6%	69%	70%
TOPAZ-MBK-IPI TOPAZD-PMH-IPI TOPAZD-MBK-IPI TOPAZD-CSB-IPI (Propane)	(0-2000 FT) 34,000	26,000	50	69.4%	69%	69%



# 3 Important Safety and Operating Information

## A. Appliance Safety

**WARNING! DO NOT operate stove before reading and understanding operating instructions.** Failure to operate stove according to operating instructions could cause fire or injury.

 <b>WARNING</b>

<b>HOT GLASS WILL CAUSE BURNS. DO NOT TOUCH GLASS UNTIL COOLED. NEVER ALLOW CHILDREN TO TOUCH GLASS.</b>
<ul style="list-style-type: none"><li>• Keep children away.</li><li>• CAREFULLY SUPERVISE children in same room as stove.</li><li>• Alert children and adults to hazards of high temperatures.</li></ul>
<b>High temperatures may ignite clothing or other flammable materials.</b>
<ul style="list-style-type: none"><li>• Clothing, furniture, draperies, and other flammable materials must not be placed on or near the appliance.</li></ul>

Young children should be carefully supervised when they are in the same room as the appliance. Toddlers, young children and others may be susceptible to accidental contact burns.

- A physical barrier is recommended if there are at risk individuals in the house.
- To restrict access to a stove or stove, install an adjustable safety gate to keep toddlers, young children and other at risk individuals out of the room and away from hot surfaces.
- Install a switch lock or a wall/remote control with child protection lockout feature.
- Keep remote controls out of reach of children.
- Never leave children alone near a hot stove, whether operating or cooling down.
- Teach children to NEVER touch the stove.
- Consider not using the stove when children will be present.

Contact your dealer for more information, or visit: [www.hpba.org/safety-information](http://www.hpba.org/safety-information).

To prevent unintended operation when not using your stove for an extended period of time (summer months, vacations, trips, etc):

- Remove batteries from remote controls.
- Turn off wall controls.
- Unplug 6 volt adapter plug and remove batteries.

## Clear Space

**WARNING! DO NOT place combustible objects in front of the stove or block louvers.** High temperatures may start a fire. Figure 3.1.

Avoid placing candles and other heat-sensitive objects on top of appliance or in clear space. Figure 3.1. Heat may damage these objects. See appliance installation manual for additional clearance information.

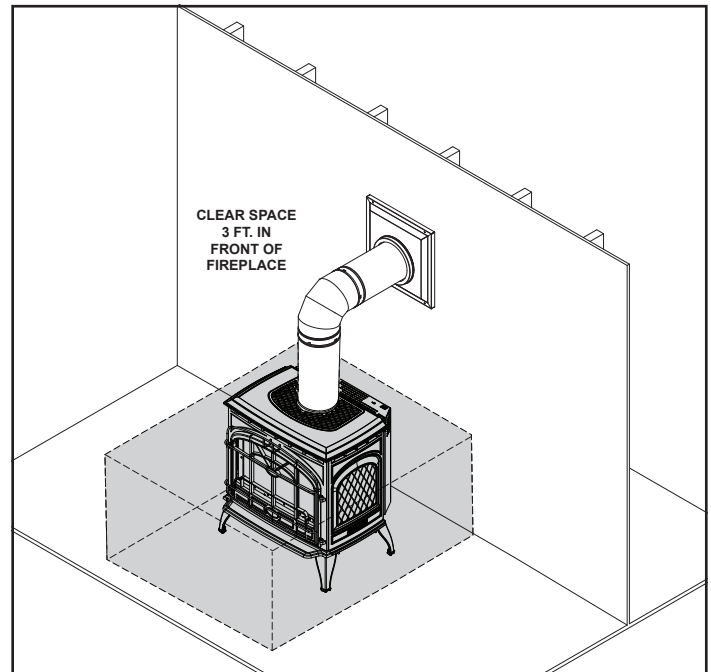



Figure 3.1 - Clear Space

## Over Firing

The appliance is considered to be over firing if the flames are contacting the top of the firebox. Call a qualified service technician to service the appliance.

## B. California Safety Warning

 <b>WARNING</b>
This product and the fuels used to operate this product (liquid propane or natural gas), and the products of combustion of such fuels, can expose you to chemicals including benzene, which is known to the State of California to cause cancer and reproductive harm. For more information go to: <a href="http://www.P65Warnings.ca.gov">www.P65Warnings.ca.gov</a> .



## C. General Operating Parts

Figure 3.2 references the general operating parts of the appliance and the section of this manual in which they are discussed.

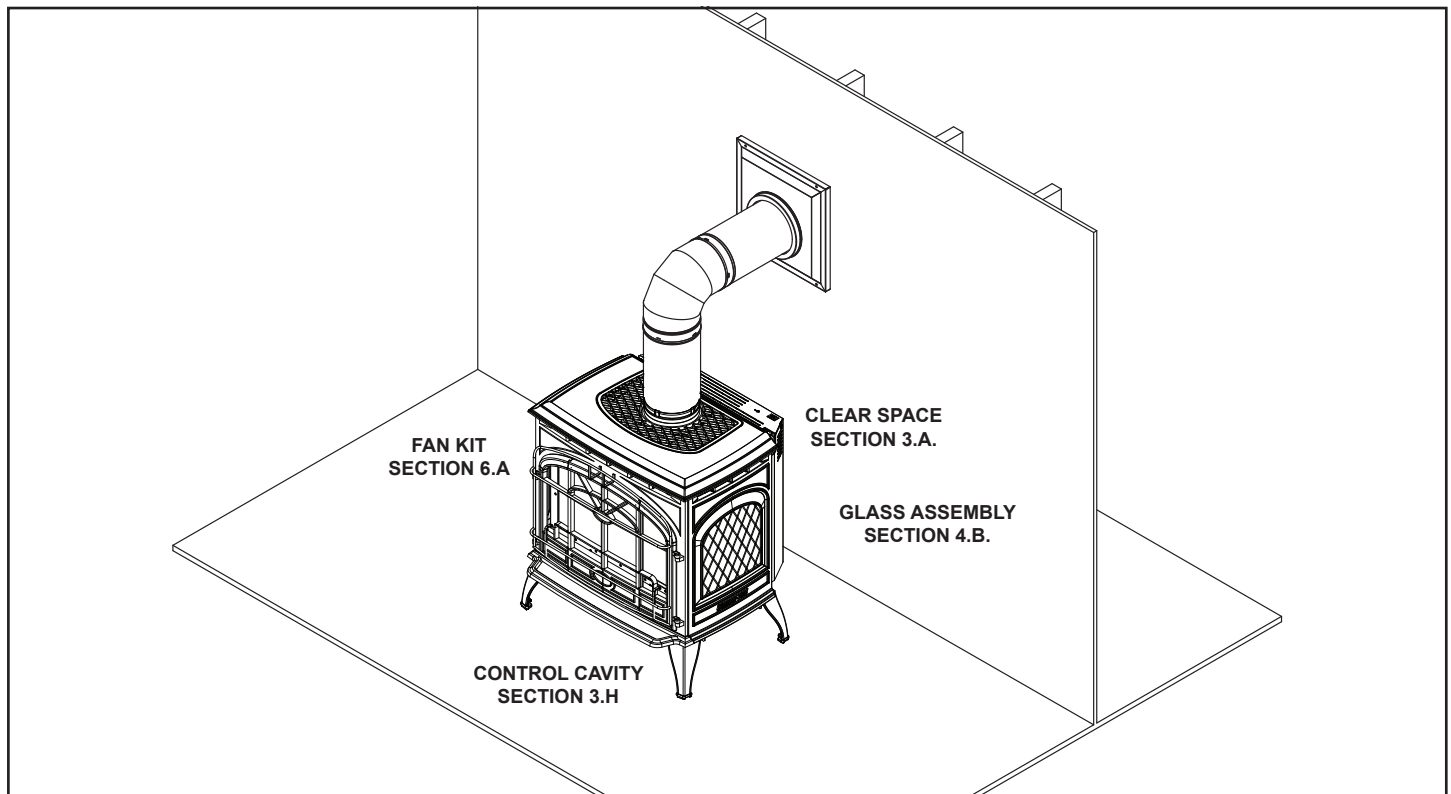

Figure 3.2 General Operating Parts

## D. Fuel Specifications



### WARNING



**RISK OF FIRE OR EXPLOSION!** *Appliance must be set up for compatible gas type!*

- This appliance is designed to operate on either natural gas or propane. Make sure the appliance is compatible with gas type selected for installation site.
- Conversions must be made by a qualified service technician using Hearth & Home Technologies specified and approved parts.

## E. Before Lighting Appliance

Before operating this stove for the first time, **have a qualified service technician:**

- Verify all shipping materials have been removed from inside and/or underneath the firebox.
- Review proper placement of logs, ember material and/or other decorative materials.
- Check the wiring.
- Check the air shutter adjustment.
- Ensure that there are no gas leaks.
- Ensure that the glass is sealed and in the proper position and that the integral barrier is in place.



### WARNING



**RISK OF FIRE OR ASPHYXIATION! DO NOT** operate stove with fixed glass assembly removed.

## F. Lighting Instructions (IPI)

### FOR YOUR SAFETY READ BEFORE LIGHTING

**WARNING:** If you do not follow these instructions exactly, a fire or explosion may result causing property damage, personal injury or loss of life.

- A. This appliance is equipped with an intermittent pilot ignition (IPI) device which automatically lights the burner. **DO NOT** try to light the burner by hand.
- B. **BEFORE LIGHTING**, smell all around the appliance area for gas. Be sure to smell next to the floor because some gas is heavier than air and will settle on the floor.
- WHAT TO DO IF YOU SMELL GAS**
- **DO NOT** try to light any appliance.
  - **DO NOT** touch any electric switch; do not use any phone in your building.
  - Immediately call your gas supplier from a neighbor's phone. Follow the gas supplier's instructions.
  - If you cannot reach your gas supplier, call the fire department.
- C. Use only your hand to push in or turn the gas control knob. Never use Tools. If the knob will not push in or turn by hand, **DO NOT** try to repair it, call a qualified service technician. Force or attempted repair may result in a fire or explosion.
- D. **DO NOT** use this appliance if any part has been under water. Immediately call a qualified service technician to inspect the appliance and to replace any part of the control system and any gas control which has been under water.

### LIGHTING INSTRUCTIONS (IPI)

1. This appliance is equipped with an ignition device which automatically lights the burner. **DO NOT** try to light the burner by hand.
2. Wait five (5) minutes to clear out any gas. Then smell for gas, including near the floor. If you smell gas, STOP! Follow "B" in the Safety Information located on the left side of this label. If you do not smell gas, go to next step.
3. To light the burner:  
Equipped with wall switch: Turn ON/OFF switch to ON.  
Equipped with remote or wall control: Press ON or FLAME button.  
Equipped with thermostat: Set temperature to desired setting.
4. If the appliance does not light after three tries, call your service technician or gas supplier.

**GAS VALVE**

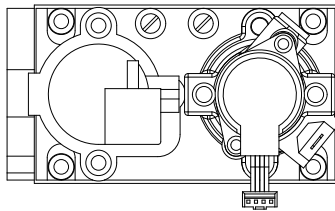

### TO TURN OFF GAS TO APPLIANCE

1. Equipped with wall switch: Turn ON/OFF switch to OFF.  
Equipped with remote or wall control: Press OFF button.  
Equipped with thermostat: Set temperature to lowest setting.
2. Service technician should turn off electric power to the control when performing service.

**! DANGER**



**HOT GLASS WILL CAUSE BURNS.  
DO NOT TOUCH GLASS UNTIL COOLED.  
NEVER ALLOW CHILDREN TO TOUCH GLASS.**

A barrier designed to reduce the risk of burns from the hot viewing glass is provided with this appliance and shall be installed for the protection of children and other at-risk individuals.

### WARNING:

**DO NOT CONNECT LINE VOLTAGE (110/120 VAC OR 220/240 VAC) TO THE CONTROL VALVE.**

Improper installation, adjustment, alteration, service or maintenance can cause injury or property damage. Refer to the owner's information manual provided with this appliance.

This appliance needs fresh air for safe operation and must be installed so there are provisions for adequate combustion and ventilation air.

If not installed, operated, and maintained in accordance with the manufacturer's instructions, this product could expose you to substances in fuel or fuel combustion which are known to the State of California to cause cancer, birth defects, or other reproductive harm.

Keep burner and control compartment clean. See installation and operating instructions accompanying appliance.

### CAUTION:

Hot while in operation. **DO NOT** touch. Keep children, clothing, furniture, gasoline and other liquids having flammable vapors away.

**DO NOT** operate the appliance with fixed glass assembly removed, cracked or broken. Replacement of the fixed glass assembly should be done by a licensed or qualified service person.

### NOT FOR USE WITH SOLID FUEL

For use with natural gas and propane. A conversion kit, as supplied by the manufacturer, shall be used to convert this appliance to the alternate fuel.

**Also Certified for Installation in a Bedroom or a Bedsitting Room.**

For assistance or additional information, consult a qualified installer, service agency or the gas supplier.

For additional information on operating your  
Hearth & Home Technologies stove, please refer to [www.fireplaces.com](http://www.fireplaces.com).

593-913i

## G. Appliance Break-In

### Initial Break-in Procedure

- The stove should be run three to four hours continuously on high.
- Turn the stove off and allow it to completely cool.
- Remove fixed glass assembly. Section 4.B.
- Clean fixed glass assembly. Section 4.
- Replace the fixed glass assembly and run continuously on high an additional 12 hours.

This cures the materials used to manufacture the stove.

***NOTICE! Open windows for air circulation during stove break-in.***

- *Some people may be sensitive to smoke and odors.*
- *Smoke detectors may activate.*

## H. Heat Management

### Heat Output

This model has a variable burn rate which is controlled by the HI/LO switch on the control module. Therefore the flame height is adjustable. The HI/LO switch is shown in Figure 3.6. It is located in the control cavity of the appliance.

If a remote control is installed, the flame height may also be controlled by the remote, if flame height is a function of that particular model of remote control.

If an optional fan is installed, the fan speed is controlled by adjusting the speed control knob. Turn the knob clockwise to increase the fan speed and counterclockwise to decrease the fan speed.

## I. Operation During A Power Outage (IPI Plus)

The IntelliFire™ Plus intermittent pilot ignition system comes with a battery backup system that enables the system to operate in a power outage. The system offers seamless transition from household AC power to battery backup. A factory-installed battery pack is located in the control cavity of the appliance. Figure 3.6. Battery longevity and performance will be affected by long term exposure to the service temperatures of this appliance.

**NOTICE:** Batteries should only be used as a power source in the event of an emergency power outage. Batteries should not be used as a primary long-term power source.

### To Operate stove Using Battery Power (DC):

1. Access the control cavity of the appliance. See Figure 3.5 for location.
2. Locate the battery tray and insert four AA cell batteries. Battery polarity must be correct or module damage will occur. Figure 3.6. A complete wiring diagram is included in the Electrical section of the appliance Installation Manual.
3. Turn the appliance on according to the instructions below for the appropriate type of control:

### Factory-Installed ON/OFF Switch:

- Toggle the switch as you would under normal circumstances. Figure 3.5

### Wireless Remote:

- Remote receiver is integrated into the ignition module
- Use the remote to turn the appliance on.
- To preserve battery life, do not use the HI/LO flame or THERMOSTAT options.

### Ignition Module:

- Locate the ignition module in the control cavity. Figure 3.6
- Slide the ON/OFF/REMOTE switch to the ON position.

**NOTICE:** Some functionality will be lost when using battery backup including remote control, fan, or any other auxiliary functions that require household 110-120 VAC power.

## To Return to Operation Using Electrical (AC) Power

### Factory-Installed ON/OFF Switch:

- Toggle the switch to OFF and remove the batteries from the battery tray.

### Wireless Remote:

- Slide the ON/OFF/REMOTE switch to the REMOTE position. Remove the batteries from the battery tray.

### Ignition Module:

- Slide the ON/OFF/REMOTE switch to the REMOTE position.

Remove the batteries from the battery tray.

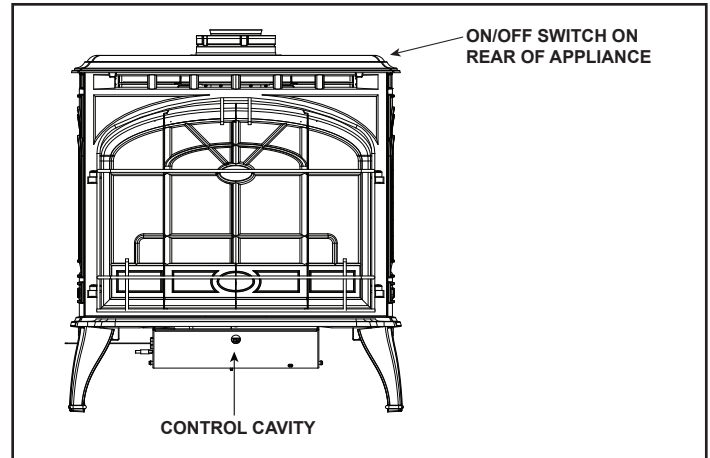

Figure 3.5 - ON/OFF Switch/Control Cavity Location

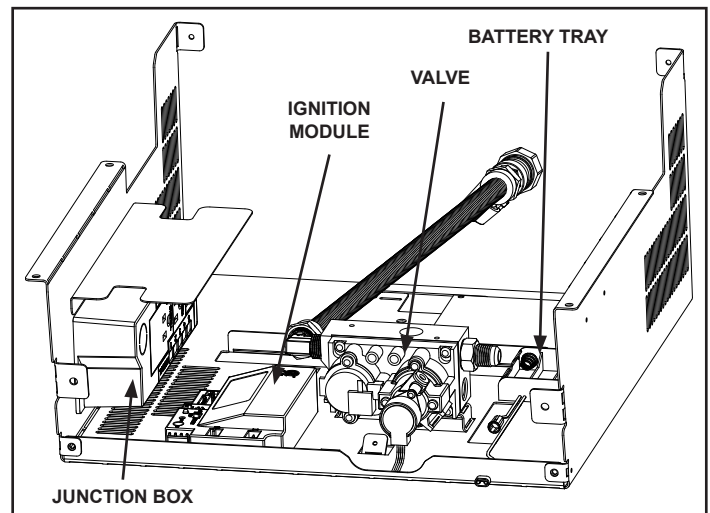

Figure 3.6

## J. Detailed Component Operating Instructions - IntelliFire Plus

### Control Module Operation

1. The control module has an ON/OFF/REMOTE selector switch that must be set. Figure 3.7.

OFF Position: Appliance will ignore all power inputs and will not respond to any commands from a wall switch or remote. The unit should be in the OFF position during installation, service, battery installation, fuel conversion, and in the event that the control goes into LOCK-OUT mode as a result of an error code.

ON Position: Appliance will ignite and run continuously in the HI flame setting, with no adjustment in flame output. This mode of operation is primarily used for initial installation or power outage operation with battery backup.

REMOTE Position: Appliance will initiate commands from an optional wired wall switch and/or the wireless remote (RC100, RC200, RC300).

2. If using the wired switch in the control cavity with the module in REMOTE mode, the flame output can be adjusted with the HI/LO selector switch on the module. Figure 3.7. Note that the flame HI/LO selector switch will become inactive once an optional remote control (RC200/RC300) is programmed to the control module. Note that the control module will always ignite the stove on HI and remain so for the initial 10 seconds of operation. If the HI/LO is switched to the LO position, the flame output will automatically drop to the lowest setting after the flame has been established for 10 sec. After this 10 second period, the flame can be adjusted from HI to LO with the switch.
3. The control module has safety feature that automatically shuts down the stove after 9 hours of continuous operation without receiving a command from the RC300 remote.
4. If you intend to use both the wired appliance switch and the RC300 remote control to operate your stove, the appliance switch will override any commands given by the remote.

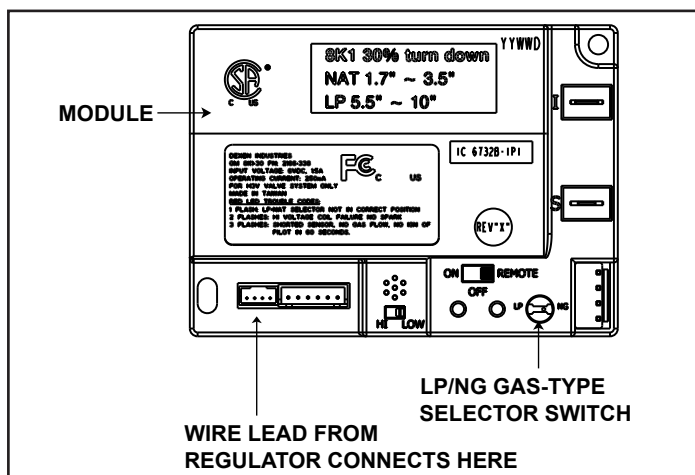

Figure 3.7 - Control Module

### 5. Module Reset

This module may lock-out under certain conditions. When this occurs, the appliance will not ignite or respond to commands. The module will go into lock-out mode by emitting three audible beeps, then continuously displaying a RED/GREEN error code at its status indicator LED.

- Check battery tray. Remove batteries if installed. Batteries should only be installed for use during power outages. See Section H.
- Locate the module selector switch. (Figure 3.7).
- Set the module selector switch to the OFF position.
- Wait five (5) minutes to allow possible accumulated gas to clear.
- Set the module selector switch to ON or REMOTE position.
- Start the appliance.

**WARNING! Risk of Explosion! DO NOT press the module reset switch more than one time within a five minute time period. Gas may accumulate in firebox. Call a qualified service technician.**

#### Nine Hour Safety Shutdown Feature

The appliance has a safety feature that automatically shuts down the stove after nine hours of continuous operation without receiving a command from the wall switch or optional remote.

### Appliance ON/OFF

If an optional remote control or wall control is installed, it should be used to control the ON/OFF function of the appliance. Follow instructions included with the installed control.

To operate the appliance without a wall control or remote control, use the ON/OFF switch located on the front panel of the control cavity of the appliance. Figure 3.5.

**CAUTION! Risk of Electric Shock! Avoid touching wires and electrical components in appliance control cavity.**

### Optional Fan Operation

If desired, a fan kit may be added. Contact your dealer to order the correct fan kit. Heat management for the fan is discussed in Section 3.G. Detailed instructions are included with the fan kit.

# 4 Maintenance and Service

Any safety screen or guard removed for servicing must be replaced prior to operating the stove.

When properly maintained, your stove will give you many years of trouble-free service. **Contact your dealer** to answer questions regarding proper operation, troubleshooting and service for your appliance. Visit [www.quadra-fire.com](http://www.quadra-fire.com) to locate a dealer. We recommend annual service by a qualified service technician.

## A. Maintenance: Frequency and Tasks

Task	Frequency	To be completed by
Glass Cleaning	Seasonally	Homeowner
Remote Control	Seasonally	
Venting	Seasonally	
Gasket Seal and Glass Inspection	Annually	Qualified Service Technician
Log Inspection	Annually	
Firebox Inspection	Annually	
Control Compartment & firebox Top	Annually	
Burner Ignition & Operation	Annually	

## B. Maintenance Tasks - Homeowner

Installation and repair should be done by a qualified service technician only. The stove should be inspected before use and at least annually by a professional service person.

The following tasks may be performed annually by the homeowner. If you are uncomfortable performing any of the listed tasks, please call your dealer for a service appointment.

More frequent cleaning may be required due to lint from carpeting or other factors. Control compartment, burner and circulating air passageway of the stove must be kept clean.

**CAUTION! Risk of Burns!** The stove should be turned off and cooled before servicing.

### Glass Cleaning

**Frequency:** Seasonally

**By:** Homeowner

**Tools Needed:** Protective gloves, glass cleaner, drop cloth and a stable work surface.

**CAUTION! Handle fixed glass assembly with care.**

### GLASS IS BREAKABLE.

- Avoid striking, scratching or slamming glass.
  - Avoid abrasive cleaners.
  - **DO NOT** clean glass while it is hot.
  - Prepare a work area large enough to accommodate fixed glass assembly and door frame by placing a drop cloth on a flat, stable surface.
- Note:** Fixed glass assembly and gasketing may have residue that can stain carpeting or floor surfaces.
- Remove safety barrier
  - Remove front casting by loosening thumb screw at bottom of casting. Slide bottom of casting away from appliance.

**CAUTION! Risk of Injury!** Casting is very heavy. Handle with care.

See Figure 4.1. Set front casting aside on prepared work surface.

- Remove glass from appliance. Figure 4.2.
- Using a #2 Phillips bit, remove three fasteners from the top of the glass frame assembly.

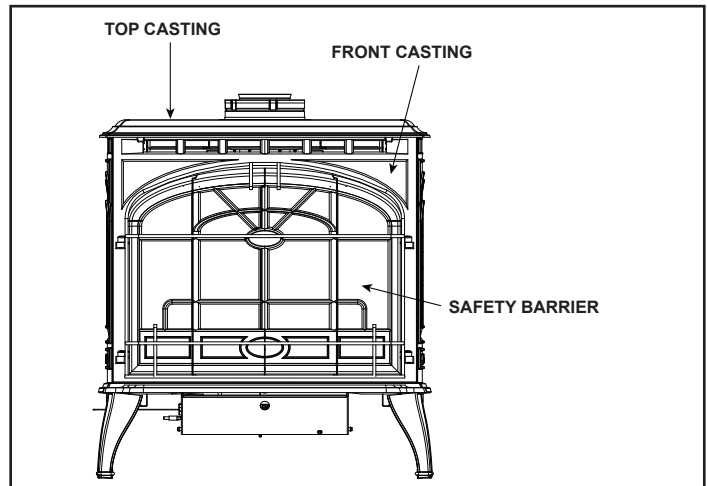

Figure 4.1 Remove Casting

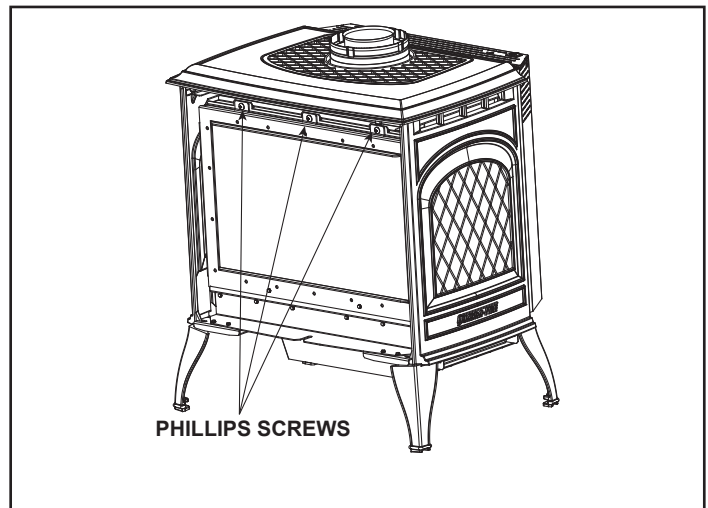

Figure 4.2 Remove Glass Frame



- Clean glass with a non-abrasive commercially available cleaner.
  - Light deposits: Use a soft cloth with soap and water.
  - Heavy deposits: Use commercial stove glass cleaner (consult with your dealer).
- Reinstall the glass frame by reattaching the three Phillips head fasteners. Tighten until snug. Do not overtighten.
- Reinstall front casting.
- Reinstall safety barrier

## Remote Control

**Frequency:** Seasonally

**By:** Homeowner

**Tools needed:** Replacement batteries and remote control instructions.

- Locate remote control transmitter and receiver.
- Verify operation of remote. Refer to remote control operation instructions for proper calibration and setup procedure.
- Place batteries as needed in remote transmitters and battery-powered receivers.
- Place remote control out of reach of children.

If not using your stove for an extended period of time (summer months, vacations/trips, etc), to prevent unintended operation:

- Remove batteries from remote controls.
- Unplug 6 volt adapter plug on IPI models.

## Venting

**Frequency:** Seasonally

**By:** Homeowner

**Tools needed:** Protective gloves and safety glasses.

- Inspect venting and termination cap for blockage or obstruction such plants, bird nests, leaves, snow, debris, etc.
- Verify termination cap clearance to subsequent construction (building additions, decks, fences, or sheds).
- Inspect for corrosion or separation.
- Verify weather stripping, sealing and flashing remains intact.
- Inspect draft shield to verify it is not damaged or missing.



## C. Maintenance Tasks - Qualified Service Technician

The following tasks must be performed by a qualified service technician.

### Gasket Seal and Glass Assembly Inspection

**Frequency:** Annually

**By:** Qualified Service Technician

**Tools needed:** Protective gloves, drop cloth and a stable work surface.

- Inspect gasket seal and its condition.
- Inspect fixed glass assembly for scratches and nicks that can lead to breakage when exposed to heat.
- Confirm there is no damage to glass or glass frame. Replace as necessary.
- Verify that fixed glass assembly is properly retained and attachment components are intact and not damaged. Replace as necessary.

### Logs

**Frequency:** Annually

**By:** Qualified Service Technician

**Tools needed:** Protective gloves.

- Inspect for damaged or missing logs. Replace as necessary. Refer to Installation Manual for log placement instructions.
- Verify correct log placement and no flame impingement causing sooting. Correct as necessary.

### Firebox

**Frequency:** Annually

**By:** Qualified Service Technician

**Tools needed:** Protective gloves, sandpaper, steel wool, cloths, mineral spirits, primer and touch-up paint.

- Inspect for paint condition, warped surfaces, corrosion or perforation. Sand and repaint as necessary.
- Replace stove if firebox has been perforated.

### Control Compartment and Firebox Top

**Frequency:** Annually

**By:** Qualified Service Technician

**Tools needed:** Protective gloves, vacuum cleaner, dust cloths

- Vacuum and wipe out dust, cobwebs, debris or pet hair. Use caution when cleaning these areas. Screw tips that have penetrated the sheet metal are sharp and should be avoided.
- Remove all foreign objects.
- Verify unobstructed air circulation.

## Burner Ignition and Operation

**Frequency:** Annually

**By:** Qualified Service Technician

**Tools needed:** Protective gloves, vacuum cleaner, whisk broom, flashlight, voltmeter, indexed drill bit set, and a manometer.

- Verify burner is properly secured and aligned with pilot or igniter.
- Clean off burner top, inspect for plugged ports, corrosion or deterioration. Replace burner if necessary.
- Replace Glowing embers with new dime-size pieces. **DO NOT** block ports or obstruct lighting paths. Refer to Installation Manual for proper ember placement.
- Verify batteries have been removed from battery back-up IPI systems to prevent premature battery failure or leaking.
- Check for smooth lighting and ignition carryover to all ports. Verify that there is no ignition delay.
- Inspect for lifting or other flame problems.
- Verify air shutter setting is correct. See Installation Manual for required air shutter setting. Verify air shutter is clear of dust and debris.
- Inspect orifice for soot, dirt and corrosion. Verify orifice size is correct. See Service Parts List for proper orifice sizing.
- Verify manifold and inlet pressures. Adjust regulator as required.
- Inspect pilot flame pattern and strength. See Figure 4.3 for proper pilot flame pattern. Clean or replace orifice spud as necessary.
- Inspect IPI flame sensing rod for soot, corrosion and deterioration. Polish with fine steel wool or replace as required.
- Verify that there is not a short in flame sense circuit by checking continuity between pilot hood and flame sensing rod. Replace pilot as necessary.



Figure 4.3 IPI Pilot Flame Patterns

# 5 Frequently Asked Questions and Troubleshooting

## A. Frequently Asked Questions

ISSUE	SOLUTIONS
Condensation on the glass	This is a result of gas combustion and temperature variations. As the appliance warms, this condensation will disappear.
Blue flames	This is a result of normal operation and the flames will begin to yellow as the appliance is allowed to burn for 20 to 40 minutes.
Odor from appliance	When first operated, this appliance may release an odor for the first several hours. This is caused by the curing of the paint and the burning off of any oils remaining from manufacturing. If appliance has not been used for some time, dust can build up and cause an odor.
Film on the glass	This is a normal result of the curing process of the paint and logs. Glass should be cleaned within 3 to 4 hours of initial burning to remove deposits left by oils from the manufacturing process. A non-abrasive cleaner such as gas appliance cleaner may be necessary. See your dealer.
Metallic noise	Noise is caused by metal expanding and contracting as it heats up and cools down, similar to the sound produced by a furnace or heating duct. This noise does not affect the operation or longevity of the appliance.

**Contact your dealer** for additional information regarding operation and troubleshooting. Visit [www.quadra-fire.com](http://www.quadra-fire.com) to locate a dealer.

## B. Troubleshooting

### IntelliFire Plus™ Ignition System

Symptom	Possible Cause	Corrective Action
1. Pilot won't light. The ignitor/module makes noise, but no spark.	A. Incorrect wiring.	Verify "S" wire (white) for sensor and "I" wire (orange) for ignitor are connected to correct terminals on module and pilot assembly.
	B. Loose connections or electrical shorts in the wiring.	Verify no loose connections or electrical shorts in wiring from module to pilot assembly. Verify connections underneath pilot assembly are tight; also verify igniter and flame sense wires are not grounding out to metal chassis, pilot burner, pilot enclosure, mesh screen if present, or any other metal object.
	C. Ignitor gap is too large.	Verify gap of igniter to right side of pilot hood. The gap should be approximately .17 in. or 1/8 in. (3 mm).
2. Pilot won't light, there is no noise or spark.	A. No power, transformer installed incorrectly, or depleted batteries.	Verify that transformer is installed and plugged into module. Check voltage of transformer at connection to module. Acceptable readings of a good transformer are between 6.4 and 6.6 volts DC. Battery power supply voltage must be at least 4 volts. If less than 4 volts, replace batteries.
	B. A shorted or loose connection in wiring configuration or wiring harness.	Remove and reinstall the wiring harness that plugs into module. Verify there is a tight fit. Verify pilot assembly wiring to module. Remove and verify continuity of each wire in wiring harness. Replace any damaged components.
	C. Improper wall switch wiring.	Verify that 110-120 VAC power is "ON" to junction box.
	D. Module not grounded.	Verify black ground wire from module wire harness is grounded to metal chassis of appliance.
3. Pilot sparks, but Pilot will not light.	A. Gas supply.	Verify that incoming gas line ball valve is "open". Verify that inlet pressure reading is within acceptable limits.
	B. Ignitor gap is too large.	Verify gap of igniter to right side of pilot hood. The gap should be approximately .17 in. or 1/8 in. (3 mm).
	C. Module is not grounded.	Verify module is securely grounded to metal chassis of appliance.
	D. Pilot valve solenoid.	Verify that 1.5 to 1.8 VDC is supplied to pilot solenoid from module. If below 1.5 volts, replace module. If 1.5 volts or greater, replace valve.

## Intellifire Plus™ Ignition System - (continued)

Symptom	Possible Cause	Corrective Action
4. Pilot lights but continues to spark, and main burner will not ignite. (If the pilot continues to spark after the pilot flame has been lit, flame rectification has not occurred.)	A. A shorted or loose connection in flame sensing rod.	Verify all connections to wiring diagram in manual. Verify connections underneath pilot assembly are tight. Verify flame sense or igniter wires are not grounding out to metal chassis, pilot burner, pilot enclosure or screen if present, or any other metal object.
	B. Poor flame rectification or contaminated flame sensing rod.	With fixed glass assembly in place, verify that flame is engulfing flame sensing rod on left side of pilot hood. Flame sensing rod should glow shortly after ignition. With a multi-meter, verify that current in series between module and sense lead is at least 0.14 microamps. Verify correct pilot orifice is installed and gas inlet is set to pressure specifications. Polish flame sensing rod with fine steel wool to remove any contaminants that may have accumulated on flame sensing rod.
	C. Module is not grounded.	Verify module is securely grounded to metal chassis of appliance. Verify that wire harness is firmly connected to the module.
	D. Damaged pilot assembly or contaminated flame sensing rod.	Verify that ceramic insulator around the flame sensing rod is not cracked, damaged, or loose. Verify connection from flame sensing rod to white sensor wire. Polish flame sensing rod with fine steel wool to remove any contaminants that may have accumulated on flame sensing rod. Verify continuity with a multi-meter with ohms set at lowest range. Replace pilot if any damage is detected.
5. Appliance lights and runs for a few minutes and then shuts down and/or appliance cycles on and off.	A. A shorted or loose connection in flame sensing rod.	Verify all connections to wiring diagram in manual. Verify connections underneath pilot assembly are tight. Verify flame sense or igniter wires are not grounding out to metal chassis, pilot burner, pilot enclosure or screen if present, or any other metal object.
	B. Poor flame rectification or contaminated flame sensing rod.	With fixed glass assembly in place, verify that flame is engulfing flame sensing rod on left side of pilot hood. Flame sensing rod should glow shortly after ignition. With a multi-meter, verify that current in series between module and sense lead is at least 0.14 microamps. Verify correct pilot orifice is installed and gas inlet is set to pressure specifications. Polish flame sensing rod with fine steel wool to remove any contaminants that may have accumulated on flame sensing rod.
	C. Logs are set up incorrectly.	Remove and reinstall logs per the log placement instructions.
	D. Damaged pilot assembly or contaminated flame sensing rod.	Verify that ceramic insulator around the flame sensing rod is not cracked, damaged, or loose. Verify connection from flame sensing rod to white sensor wire. Polish flame sensing rod with fine steel wool to remove any contaminants that may have accumulated on flame sensing rod. Verify continuity with a multi-meter with ohms set at lowest range. Replace pilot if any damage is detected.

# 6 Reference Materials

---

## A. Accessories

Install approved accessories per instructions included with accessories. Contact your dealer for a list of approved accessories.

***WARNING! Risk of Fire and Electric Shock! Use ONLY Hearth & Home Technologies-approved optional accessories with this appliance. Using non-listed accessories could result in a safety hazard and will void the warranty.***

### Remote Controls Switches

After a qualified service technician has installed the remote control, follow the instructions supplied with the control installed to operate your stove:

For safety:

- Install a switch lock or a remote control with child protection lockout feature.
- Keep remote controls out of reach of children.

See your dealer if you have questions.

### Optional Fan

If an optional fan is purchased, have it installed by a qualified service technician. Section 3 discusses using the fan to manage the heat output. Follow the instructions supplied with the fan kit to operate your fan.

See your dealer if you have questions.

TOPAZ-MBK-IPI, TOPAZD-CSB-IPI, TOPAZD-MBK-IPI, TOPAZD-PMH-IPI

**Log Set Assembly**

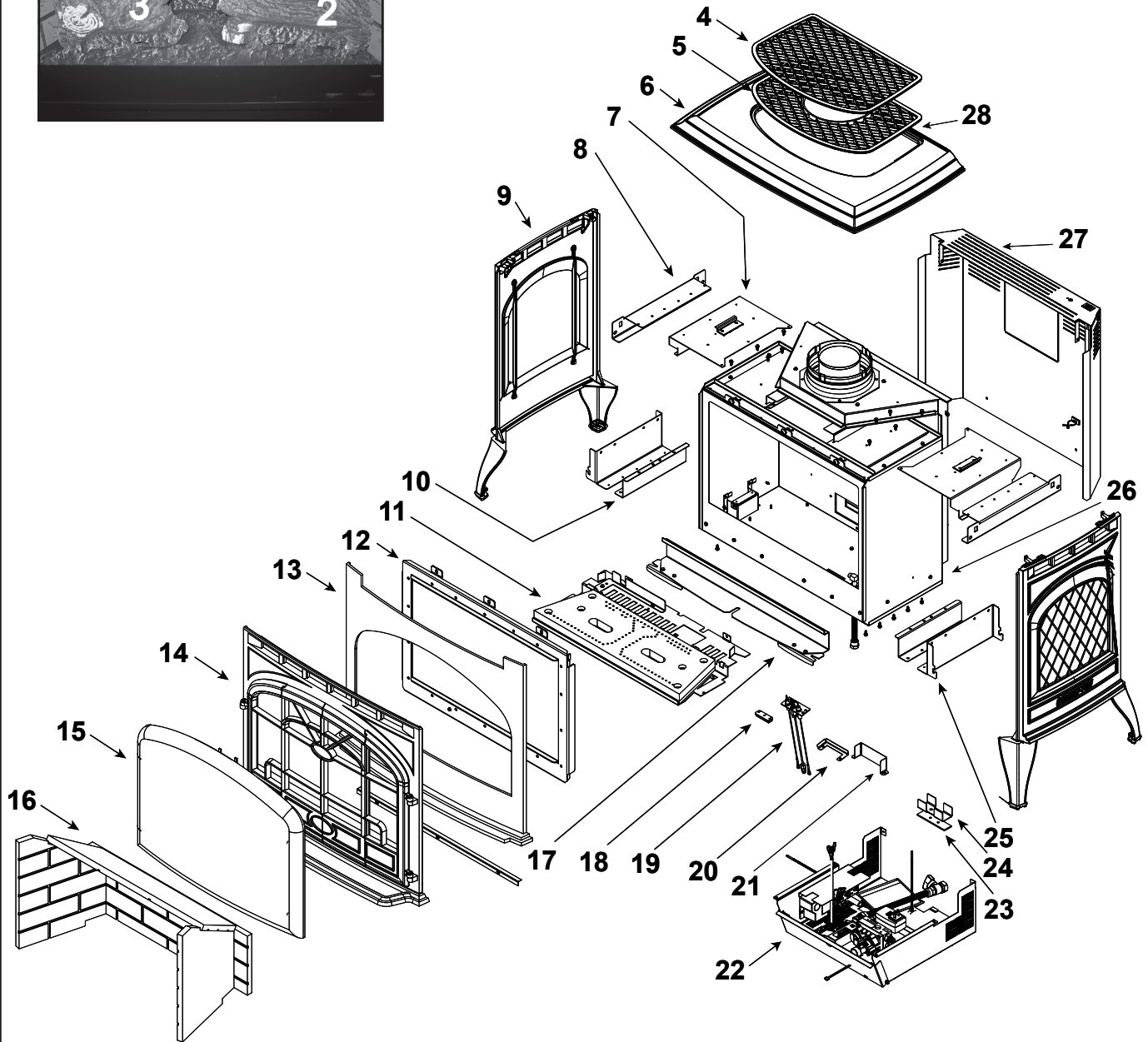

Part number list on following page.

07/19

IMPORTANT: THIS IS DATED INFORMATION. Parts must be ordered from a dealer or distributor. **Hearth and Home Technologies does not sell directly to consumers.** Provide model number and serial number when requesting service parts from your dealer or distributor.



**Stocked  
at Depot**

ITEM	DESCRIPTION	COMMENTS	PART NUMBER	Stocked at Depot
	Log Set Assembly		LOGS-T2	Y
1	Log #1	Rear	SRV7011-147	
2	Log #2	Right Front	SRV7011-145	
3	Log #3	Left Front	SRV7011-146	
4	Grill, Rear Vent	Black	RV-TPZ-MBK-IPI	
		Mahogany	RV-TPZ-PMH-IPI	
		Sienna Bronze	RV-TPZ-CSB-IPI	
5	Grill Top Vent	Black	468-0040MBK	
		Mahogany	468-0040PMH	
		Sienna Bronze	468-0040CSB	
6	Top	Black	468-0010MBK	
		Mahogany	468-0010PMH	
		Sienna Bronze	468-0010CSB	
7	Shroud, Upper Fan	Qty 2 req	2340-130	
8	Bracket, Top Mounting	Qty 2 req	2341-131	
9	Side Kit - Side Replacement	Black	SIDE-TPZ-MBK	
		Mahogany	SIDE-TPZ-PMH	
		Sienna Bronze	SIDE-TPZ-CSB	
10	Bracket, Bottom Mounting Inner	Qty 2 req	2341-107	
11	Burner Assembly		2340-007	Y
12	Glass Assembly		GLA2340-019	Y
	Button Head, 1/4-20x5/8 Black	Pkg of 10	1201529-10	
13	Face Assembly, Solitaire	Solitaire Face Black	7009-007MBK	
14	Face Assembly, Quartet	Black	466-5000MBK	
		Mahogany	466-5000PMH	
		Sienna Bronze	466-5000CSB	
	Ashlip	Black	466-0060MBK	
		Mahogany	466-0060PMH	
		Sienna Bronze	466-0060CSB	
	Door Assembly Left	Black	466-5030MBK	
		Mahogany	466-5030PMH	
		Sienna Bronze	466-5030CSB	
	Door Assembly Right, Quartet	Black	466-5020MBK	
		Mahogany	466-5020PMH	
		Sienna Bronze	466-5020CSB	
	Face	Black	466-0010MBK	
		Mahogany	466-0010PMH	
		Sienna Bronze	466-0010CSB	

Additional service part numbers appear on following page.





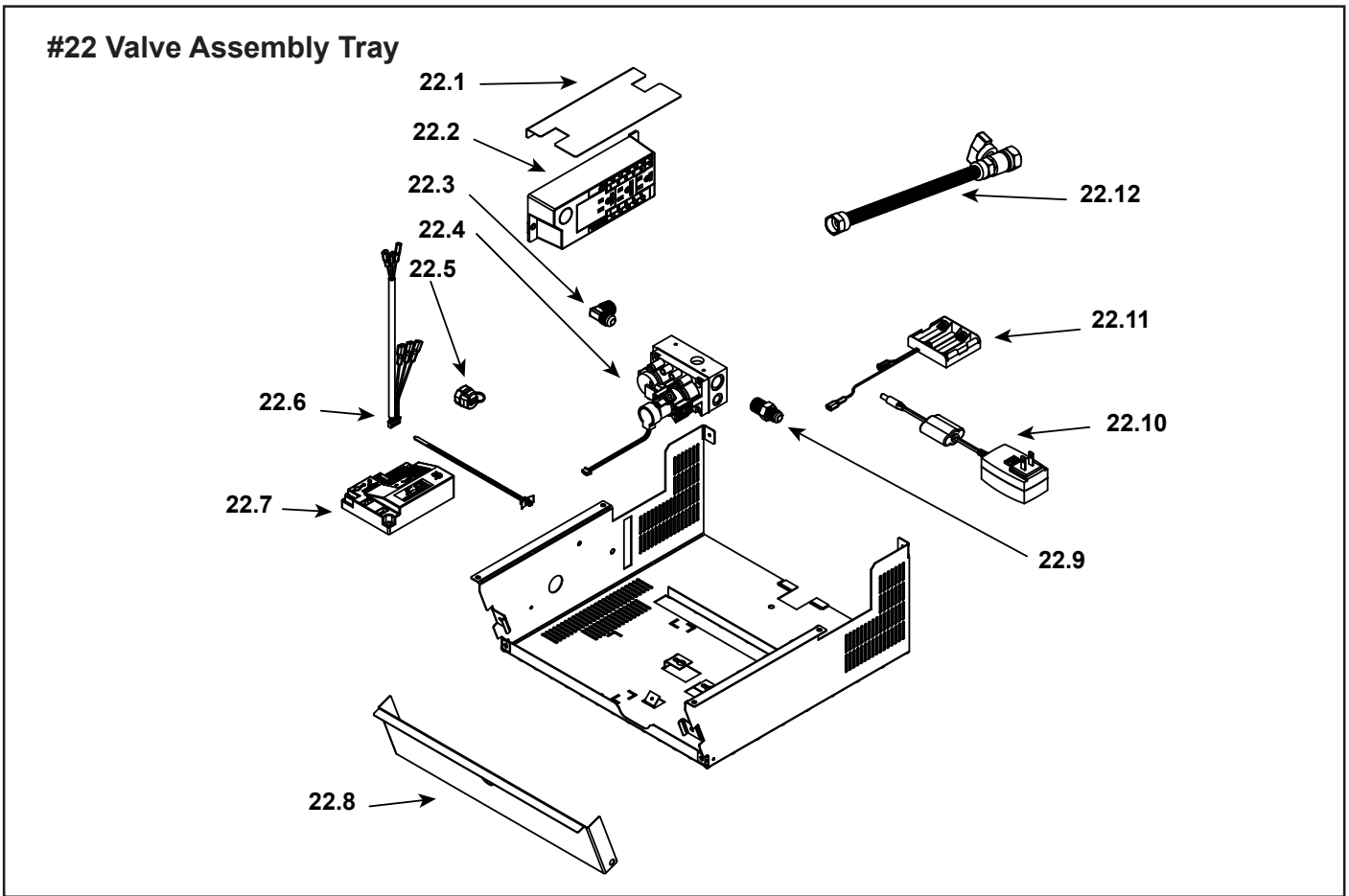

IMPORTANT: THIS IS DATED INFORMATION. Parts must be ordered from a dealer or distributor. **Hearth and Home Technologies does not sell directly to consumers.** Provide model number and serial number when requesting service parts from your dealer or distributor.



**Stocked at Depot**

ITEM	DESCRIPTION	COMMENTS	PART NUMBER	
22.1	Heat Shield, J-box		2342-132	
22.2	Junction Box		SRV4021-013	Y
22.3	Elbow, 3/8" OD Flare x 3/8" NPT		SRV4021-045	
22.4	Valve, IPI	<b>NG</b>	2166-302	Y
		<b>Propane</b>	2166-303	Y
22.5	Cord Clamp		3-20-12402	
22.6	Wire Harness		2166-304	Y
22.7	Module		2166-338	Y
22.8	Access Door		2342-112	
22.9	Male Connector	Pkg of 5	303-315/5	Y
22.10	Transformer, 6V		SRV2326-131	Y
22.11	Battery Pack**		SRV2166-323	Y
22.12	Ball Valve Assembly, 24"		3-40-2098034	Y
	<b>Power Cord</b>		832-2410	

\*\*Fuse for battery pack can be sourced locally, not a warranty item. Specs are 250v, 1A fuse, 3/4" long

Additional service part numbers appear on following page.

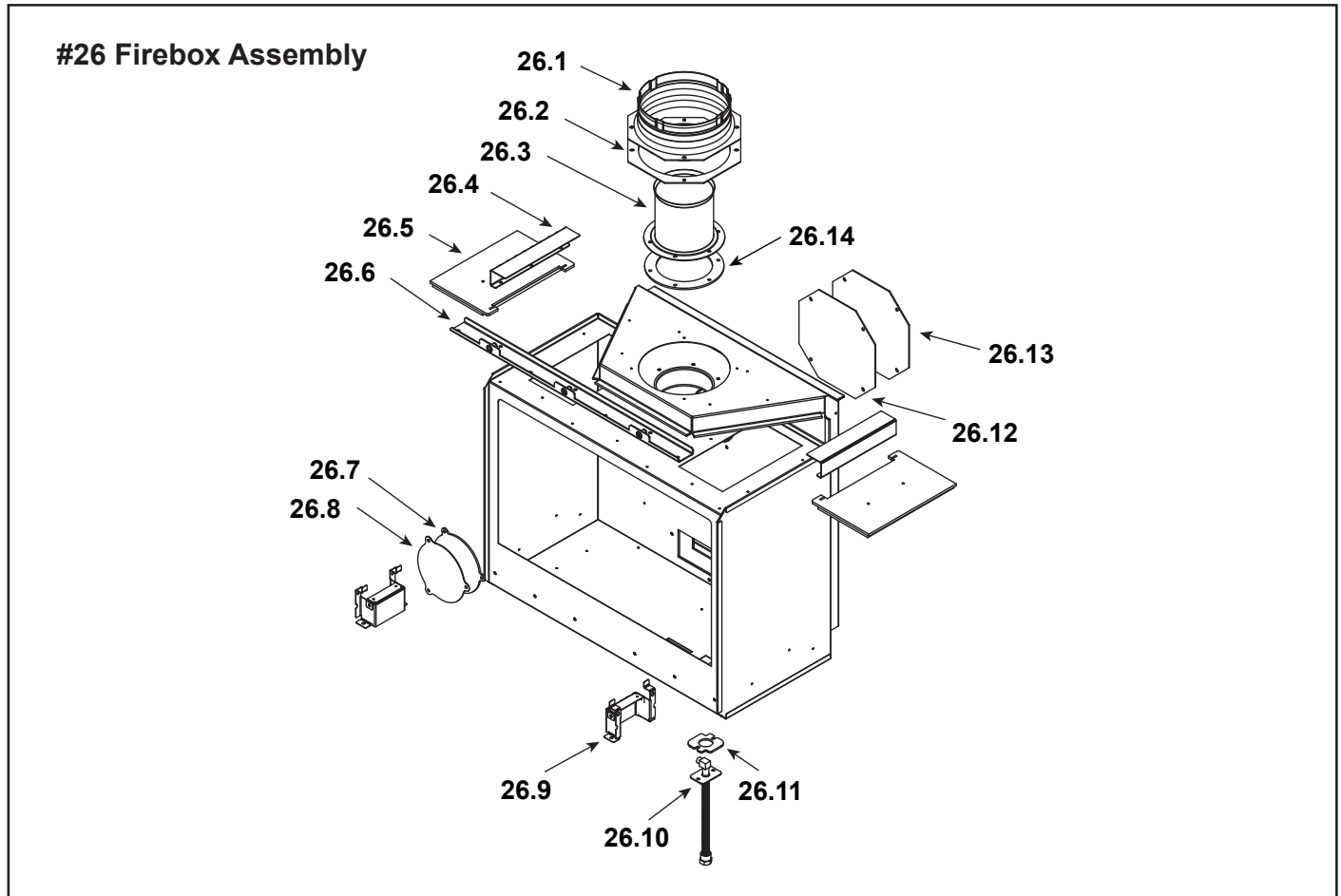

IMPORTANT: THIS IS DATED INFORMATION. Parts must be ordered from a dealer or distributor. **Hearth and Home Technologies does not sell directly to consumers.** Provide model number and serial number when requesting service parts from your dealer or distributor.



**Stocked  
at Depot**

ITEM	DESCRIPTION	COMMENTS	PART NUMBER	
26.1	Starting Collar		2189-002	
26.2	Gasket, Adaptor		460-0610	
26.3	Flue Assembly		2340-025	
26.4	Relief Door Guide		2340-133	
26.5	Relief Door Assembly		2340-020	
26.6	Firebox Support		2340-115	
26.7	Gasket, Flue Cover		2340-135	
26.8	Flue Cover		2340-134	
26.9	Bracket, Burner Mounting		2342-110	
26.10	Bulkhead		SRV7000-156	<b>Y</b>
26.11	Gasket, Burner Neck		2025-407	
26.12	Cover Plate		7010-159	
26.13	Gasket, Cover Plate		7010-160	
26.14	Gasket Spacer		2340-203	

Additional service part numbers appear on following page.





