

This appliance has been retired.  
For replacement parts, please refer to the individual  
service parts list located on the brand websites.

# Installation Manual

## Installation and Appliance Setup

**INSTALLER:** Leave this manual with party responsible for use and operation.

**OWNER:** Retain this manual for future reference.

**NOTICE:** DO NOT discard this manual!

**heatilator**  
*The first name in fireplaces*

**Models:**

CRAVE4836

CRAVE4836ST

CRAVE6048

CRAVE6048ST

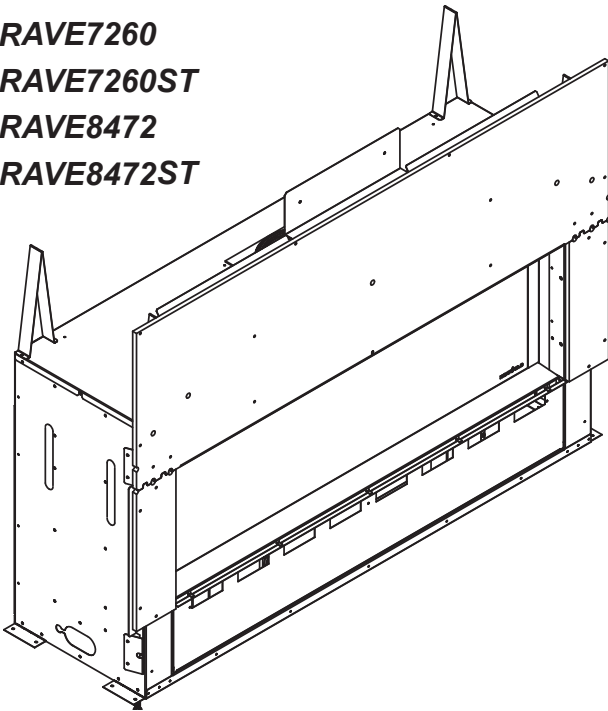
CRAVE7260

CRAVE7260ST

CRAVE8472

CRAVE8472ST

GAS-FIRED



This appliance may be installed as an OEM installation in manufactured home (USA only) or mobile home and must be installed in accordance with the manufacturer's instructions and the *Manufactured Home Construction and Safety Standard, Title 24 CFR, Part 3280* in the United States, or the *Standard for Installation in Mobile Homes, CAN/CSA Z240 MH Series*, in Canada.

This appliance is only for use with the type(s) of gas indicated on the rating plate. This appliance is not convertible for use with other gases, unless a certified kit is used.

**▲ WARNING:**  
**FIRE OR EXPLOSION HAZARD**  
Failure to follow safety warnings exactly could result in serious injury, death, or property damage.

- **DO NOT** store or use gasoline or other flammable vapors and liquids in the vicinity of this or any other appliance.
- **What to do if you smell gas**
  - **DO NOT** try to light any appliance.
  - **DO NOT** touch any electrical switch. **DO NOT** use any phone in your building.
  - Leave the building immediately.
  - Immediately call your gas supplier from a neighbor's phone. Follow the gas supplier's instructions.
  - If you cannot reach your gas supplier, call the fire department.
- Installation and service must be performed by a qualified installer, service agency, or the gas supplier.

**! DANGER**



**HOT GLASS WILL  
CAUSE BURNS.**

**DO NOT TOUCH GLASS  
UNTIL COOLED.**

**NEVER ALLOW CHILDREN  
TO TOUCH GLASS.**

A barrier designed to reduce the risk of burns from the hot viewing glass is provided with this appliance and shall be installed for the protection of children and other at-risk individuals.

In the Commonwealth of Massachusetts installation must be performed by a licensed plumber or gas fitter.

See Table of Contents for location of additional Commonwealth of Massachusetts requirements.

## ▲ Safety Alert Key:

- **DANGER!** Indicates a hazardous situation which, if not avoided will result in death or serious injury.
- **WARNING!** Indicates a hazardous situation which, if not avoided could result in death or serious injury.
- **CAUTION!** Indicates a hazardous situation which, if not avoided, could result in minor or moderate injury.
- **NOTICE:** Used to address practices not related to personal injury.

## Table of Contents

→ Installation Standard Work Checklist . . . . .	3
--	---

### 1 Product Specific and Important Safety Information

A. Appliance Certification . . . . .	4
B. Glass Specifications . . . . .	4
C. BTU Specifications . . . . .	4
D. High Altitude Installations . . . . .	5
E. Non-Combustible Materials Specification . . . . .	5
F. Combustible Materials Specification . . . . .	5
G. Electrical Codes . . . . .	5
H. Requirements for the Commonwealth of Massachusetts . . . . .	6

### 2 Getting Started

A. Design and Installation Considerations . . . . .	7
→ B. Good Faith Wall Surface/TV Guidelines . . . . .	7
C. Tools and Supplies Needed . . . . .	8
D. Inspect Appliance and Components . . . . .	8

### 3 Framing and Clearances

A. Appliance/Decorative Front Dimension Diagrams . . . . .	9
B. Clearances to Combustibles . . . . .	16
C. Constructing the Appliance Chase . . . . .	17
D. Floor Protection . . . . .	20

### 4 Termination Location and Vent Information

A. Vent Termination Minimum Clearances . . . . .	21
B. Chimney Diagram . . . . .	22
C. Approved Pipe . . . . .	23
D. Use of Elbows . . . . .	23
E. Measuring Standards . . . . .	23
F. Vent Diagrams . . . . .	23

### 5 Vent Clearances and Framing

A. Pipe Clearances to Combustibles . . . . .	31
B. Wall Penetration Framing/Firestops . . . . .	31
C. Install the Ceiling Firestop . . . . .	32
D. Install Attic Insulation Shield . . . . .	32
E. Installing the Optional Heat-Zone® Gas Kit . . . . .	33

### 6 Appliance Preparation

A. Vent Collar Preparation . . . . .	34
B. Securing and Leveling the Appliance . . . . .	35
C. Installing Non-Combustible Facing Material . . . . .	36

### 7 Venting and Chimneys

A. Assemble Vent Sections . . . . .	37
B. Assemble Slip Sections . . . . .	38
C. Secure The Vent Sections . . . . .	38
D. Disassemble Vent Sections . . . . .	39
E. Vertical Termination Requirements . . . . .	40
F. Horizontal Termination Requirements . . . . .	41

### 8 Electrical Information

A. General Information . . . . .	43
B. Wiring Requirements . . . . .	44

### 9 Gas Information

A. Fuel Conversion . . . . .	45
B. Gas Pressure . . . . .	45
C. Gas Service Access . . . . .	45
D. Gas Connection . . . . .	47
E. High Altitude Installations . . . . .	47
F. Air Shutter Setting . . . . .	48

### 10 Finishing

A. Facing and Finishing Instructions . . . . .	49
B. Mantel and Wall Projections . . . . .	56
C. Decorative Front Dimensions for Finishing . . . . .	58

### 11 Appliance Setup

A. Fixed Glass Assembly . . . . .	59
B. Remove the Shipping Materials/Install Vanity Panel . . . . .	59
C. Clean the Appliance . . . . .	59
D. Install Media . . . . .	60
E. Install Log Set . . . . .	62

### 12 Reference Materials

A. Vent Components Diagrams . . . . .	63
B. Accessories . . . . .	69

→ = Contains updated information.

→ Installation Standard Work Checklist

**ATTENTION INSTALLER:**  
**Follow this Standard Work Checklist**

This standard work checklist is to be used by the installer in conjunction with, not instead of, the instructions contained in this installation manual.

**Customer:** \_\_\_\_\_ **Date Installed:** \_\_\_\_\_  
**Lot/Address:** \_\_\_\_\_ **Location of Fireplace:** \_\_\_\_\_  
 \_\_\_\_\_ **Installer:** \_\_\_\_\_  
**Model (circle one):** CRAVE4836 CRAVE6048 CRAVE 7260 CRAVE8472 **Dealer/Distributor Phone #** \_\_\_\_\_  
 CRAVE4836ST CRAVE6048ST CRAVE 7260ST CRAVE8472ST **Serial #:** \_\_\_\_\_

 **WARNING! Risk of Fire or Explosion!** Failure to install appliance according to these instructions can lead to a fire or explosion.

**Appliance Install Sections 3 and 6**

	YES	IF NO, WHY?
Verified that the chase is insulated and sealed. (Pg. 17)	<input type="checkbox"/>	_____
Required factory included non-combustible board is in place. (Pg. 36)	<input type="checkbox"/>	_____
Verified clearances to combustibles. (Pg. 16-17)	<input type="checkbox"/>	_____
Fireplace is leveled and secured. (Pg. 35)	<input type="checkbox"/>	_____
Pipe heat shield is attached to header. Header no wider than 3.5 in.(2x4) (Pg. 18, 19, 34)	<input type="checkbox"/>	_____

**Venting/Chimney Sections 4,5 and 7**

Venting configuration complies to vent diagrams. (Pg 23-30)	<input type="checkbox"/>	_____
Venting installed, locked, and secured in place with proper clearance.	<input type="checkbox"/>	_____
Firestops installed. (Section 5)	<input type="checkbox"/>	_____
Attic insulation shield installed. (Pg 32)	<input type="checkbox"/>	_____
Exterior wall/Roof flashing installed and sealed. (Section 7)	<input type="checkbox"/>	_____
Terminations installed and sealed. (Section 7)	<input type="checkbox"/>	_____

**Electrical Section 8 (Pg 43-44)**

Unswitched power (110-120 VAC) provided to the appliance.	<input type="checkbox"/>	_____
Switch wires properly installed.	<input type="checkbox"/>	_____

**Gas Section 9 (Pg 45-48)**

Proper appliance for fuel type.	<input type="checkbox"/>	_____
Was a conversion performed?	<input type="checkbox"/>	_____
Leak check performed and inlet pressure verified.	<input type="checkbox"/>	_____
Verified proper air shutter setting for installation type.	<input type="checkbox"/>	_____

**Finishing Section 10 (Pg 49-58)**

Combustible materials not installed in non-combustible areas.	<input type="checkbox"/>	_____
Verified all clearances meet installation manual requirements.	<input type="checkbox"/>	_____
Finishing done correctly using inside fit or overlap fit method.	<input type="checkbox"/>	_____
Finishing template removed.	<input type="checkbox"/>	_____
Mantels and wall projections comply with installation manual requirements.	<input type="checkbox"/>	_____

**Appliance Setup Section 11 (Pg 59-62)**

All packaging and protective materials removed (inside & outside of appliance).	<input type="checkbox"/>	_____
Refractories and media installed correctly.	<input type="checkbox"/>	_____
Glass assembly installed and secured.	<input type="checkbox"/>	_____
Accessories installed properly.	<input type="checkbox"/>	_____
Decorative front properly installed.	<input type="checkbox"/>	_____
Manual bag and all of its contents are removed from inside/under the appliance and given to party responsible for use and operation.	<input type="checkbox"/>	_____
Started appliance and verified no gas leaks exist.	<input type="checkbox"/>	_____
Lights work in all switched positions (if so equipped).	<input type="checkbox"/>	_____
Component heat shield is installed. (Pg. 43.)	<input type="checkbox"/>	_____

**Hearth & Home Technologies recommends the following:**

- Photographing the installation and copying this checklist for your file.
- That this checklist remain visible at all times on the appliance until the installation is complete.

**Comments:** Further description of the issues, who is responsible (Installer/ Builder/ Other Trades, etc) and corrective action needed \_\_\_\_\_

Comments Communicated to party responsible \_\_\_\_\_ by \_\_\_\_\_ on \_\_\_\_\_  
 (Builder / Gen. Contractor/) (Installer) (Date)

→ = Contains updated information.

# 1 Product Specific and Important Safety Information

## A. Appliance Certification

**MODEL:** CRAVE4836, CRAVE4836ST  
 CRAVE6048, CRAVE6048ST, CRAVE6048ST-LP  
 CRAVE7260, CRAVE7260ST  
 CRAVE8472, CRAVE8472ST  
**LABORATORY:** Underwriters Laboratories, Inc. (UL)  
**TYPE:** Direct Vent Heater  
**STANDARD:** ANSI Z21.88-2014/CSA 2.33-2014

This product is listed to ANSI standards for “Vented Gas Fireplace Heaters” and applicable sections of “Gas Burning Heating Appliances for Manufactured Homes and Recreational Vehicles”, and “Gas Fired Appliances for Use at High Altitudes”.

**NOTICE:** This installation must conform with local codes. In the absence of local codes you must comply with the National Fuel Gas Code, ANSI Z223.1-latest edition in the U.S.A. and the CAN/CGA B149 Installation Codes in Canada.

**NOT INTENDED FOR USE AS A PRIMARY HEAT SOURCE.** This appliance is tested and approved as either supplemental room heat or as a decorative appliance. It should not be factored as primary heat in residential heating calculations.

CRAVE6048ST-LP available as a special order only. LP models not available in other sizes. Conversion kits available for all sizes.

## B. Glass Specifications

This appliance is equipped with 5 mm ceramic glass. Replace glass only with 5 mm ceramic glass. Please contact your dealer for replacement glass.

## C. BTU Specifications

Models (U.S. or Canada)		Maximum Input BTU/h	Minimum Input BTU/h	Orifice Size (DMS)
CRAVE4836 (NG)	(0-2000 FT)	30,000	17,500	#36
CRAVE4836 (Propane)	(0-2000 FT)	29,000	15,500	#52
CRAVE4836ST (NG)	(0-2000 FT)	30,000	17,500	#36
CRAVE4836ST (Propane)	(0-2000 FT)	29,000	15,500	#52
CRAVE6048 (NG)	(0-2000 FT)	40,000	21,000	.124
CRAVE6048 (Propane)	(0-2000 FT)	36,000	19,500	#49
CRAVE6048ST (NG)	(0-2000 FT)	40,000	21,000	.124
CRAVE6048ST (Propane)	(0-2000 FT)	36,000	19,500	#49
CRAVE7260 (NG)	(0-2000 FT)	50,000	26,000	#28
CRAVE7260 (Propane)	(0-2000 FT)	41,000	22,000	#48
CRAVE7260ST (NG)	(0-2000 FT)	50,000	26,000	#28
CRAVE7260ST (Propane)	(0-2000 FT)	41,000	22,000	#48
CRAVE8472 (NG)	(0-2000 FT)	58,000	30,000	#23
CRAVE8472 (Propane)	(0-2000 FT)	46,000	24,000	#45
CRAVE8472ST (NG)	(0-2000 FT)	58,000	30,000	#23
CRAVE8472ST (Propane)	(0-2000 FT)	46,000	24,000	#45

## D. High Altitude Installations

**NOTICE:** *If the heating value of the gas has been reduced, these rules do not apply. Check with your local gas utility or authorities having jurisdiction.*

When installing above 2000 feet elevation:

- In the USA: Reduce input rate 4% for each 1000 feet above 2000 feet.
- In CANADA: Input ratings are certified without a reduction of input rate for elevations up to 4500 feet (1370 m) above sea level. Please consult provincial and/or local authorities having jurisdiction for installations at elevations above 4500 feet (1370 m).

Check with your local gas utility to determine proper orifice size.

## E. Non-Combustible Materials Specification

Material which will not ignite and burn. Such materials are those consisting entirely of steel, iron, brick, tile, concrete, slate, glass or plasters, or any combination thereof.

Materials that are reported as passing **ASTM E 136, Standard Test Method for Behavior of Materials in a Vertical Tube Furnace at 750 °C** shall be considered non-combustible materials.

## F. Combustible Materials Specification

Materials made of or surfaced with wood, compressed paper, plant fibers, plastics, or other material that can ignite and burn, whether flame proofed or not, or plastered or unplastered shall be considered combustible materials.

## G. Electrical Codes

**NOTICE:** *This appliance must be electrically wired and grounded in accordance with local codes or, in the absence of local codes, with **National Electric Code ANSI/NFPA 70-latest edition** or the **Canadian Electric Code CSA C22.1**.*

- A 110-120 VAC circuit for this product must be protected with ground-fault circuit-interrupter protection, in compliance with the applicable electrical codes, when it is installed in locations such as in bathrooms or near sinks.

**Note:** The following requirements reference various Massachusetts and national codes not contained in this document.

## H. Requirements for the Commonwealth of Massachusetts

For all side wall horizontally vented gas fueled equipment installed in every dwelling, building or structure used in whole or in part for residential purposes, including those owned or operated by the Commonwealth and where the side wall exhaust vent termination is less than seven (7) feet above finished grade in the area of the venting, including but not limited to decks and porches, the following requirements shall be satisfied:

### Installation of Carbon Monoxide Detectors

At the time of installation of the side wall horizontal vented gas fueled equipment, the installing plumber or gas fitter shall observe that a hard wired carbon monoxide detector with an alarm and battery back-up is installed on the floor level where the gas equipment is to be installed. In addition, the installing plumber or gas fitter shall observe that a battery operated or hard wired carbon monoxide detector with an alarm is installed on each additional level of the dwelling, building or structure served by the side wall horizontal vented gas fueled equipment. It shall be the responsibility of the property owner to secure the services of qualified licensed professionals for the installation of hard wired carbon monoxide detectors.

In the event that the side wall horizontally vented gas fueled equipment is installed in a crawl space or an attic, the hard wired carbon monoxide detector with alarm and battery back-up may be installed on the next adjacent floor level.

In the event that the requirements of this subdivision can not be met at the time of completion of installation, the owner shall have a period of thirty (30) days to comply with the above requirements; provided, however, that during said thirty (30) day period, a battery operated carbon monoxide detector with an alarm shall be installed.

### Approved Carbon Monoxide Detectors

Each carbon monoxide detector as required in accordance with the above provisions shall comply with NFPA 720 and be ANSI/UL 2034 listed and IAS certified.

### Signage

A metal or plastic identification plate shall be permanently mounted to the exterior of the building at a minimum height of eight (8) feet above grade directly in line with the exhaust vent terminal for the horizontally vented gas fueled heating appliance or equipment. The sign shall read, in print size no less than one-half (1/2) in. in size, "**GAS VENT DIRECTLY BELOW. KEEP CLEAR OF ALL OBSTRUCTIONS**".

## Inspection

The state or local gas inspector of the side wall horizontally vented gas fueled equipment shall not approve the installation unless, upon inspection, the inspector observes carbon monoxide detectors and signage installed in accordance with the provisions of 248 CMR 5.08(2)(a)1 through 4.

## Exemptions

The following equipment is exempt from 248 CMR 5.08(2)(a)1 through 4:

- The equipment listed in Chapter 10 entitled "Equipment Not Required To Be Vented" in the most current edition of NFPA 54 as adopted by the Board; and
- Product Approved side wall horizontally vented gas fueled equipment installed in a room or structure separate from the dwelling, building or structure used in whole or in part for residential purposes.

## MANUFACTURER REQUIREMENTS

### Gas Equipment Venting System Provided

When the manufacturer of Product Approved side wall horizontally vented gas equipment provides a venting system design or venting system components with the equipment, the instructions provided by the manufacturer for installation of the equipment and the venting system shall include:

- Detailed instructions for the installation of the venting system design or the venting system components; and
- A complete parts list for the venting system design or venting system.

### Gas Equipment Venting System NOT Provided

When the manufacturer of a Product Approved side wall horizontally vented gas fueled equipment does not provide the parts for venting the flue gases, but identifies "special venting systems", the following requirements shall be satisfied by the manufacturer:

- The referenced "special venting system" instructions shall be included with the appliance or equipment installation instructions; and
- The "special venting systems" shall be Product Approved by the Board, and the instructions for that system shall include a parts list and detailed installation instructions.

A copy of all installation instructions for all Product Approved side wall horizontally vented gas fueled equipment, all venting instructions, all parts lists for venting instructions, and/or all venting design instructions shall remain with the appliance or equipment at the completion of the installation.

**See Gas Connection section for additional Commonwealth of Massachusetts requirements.**

# 2 Getting Started


## A. Design and Installation Considerations

Heat & Glo direct vent gas appliances are designed to operate with all combustion air siphoned from outside of the building and all exhaust gases expelled to the outside. No additional outside air source is required.


Installation MUST comply with local, regional, state and national codes and regulations. Consult insurance carrier, local building inspector, fire officials or authorities having jurisdiction over restrictions, installation inspection and permits.

Before installing, determine the following:

- Where the appliance is to be installed.
- The vent system configuration to be used.
- Gas supply piping.
- Electrical wiring requirements.
- Framing and finishing details.
- Whether optional accessories—devices such as a wall switch or remote control—are desired.



Installation and service of this appliance should be performed by qualified personnel. Hearth & Home Technologies recommends HHT Factory Trained or NFI certified professionals.



Improper installation, adjustment, alteration, service or maintenance can cause injury or property damage. For assistance or additional information, consult a qualified service technician, service agency or your dealer.

## B. Good Faith Wall Surface/TV Guidelines ←

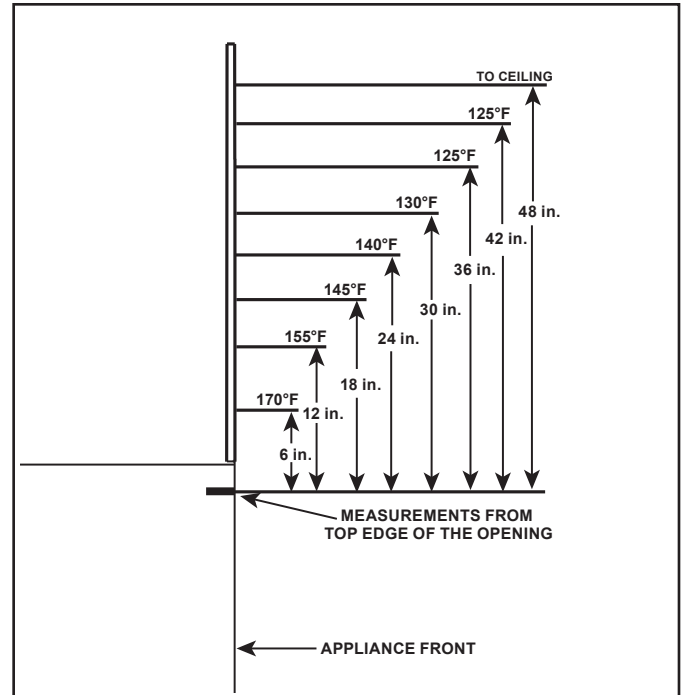


Figure 2.1. Wall Surface Temperatures Above Appliance (GRAVE4836/CRAVE4836ST/CRAVE6048/CRAVE6048ST)

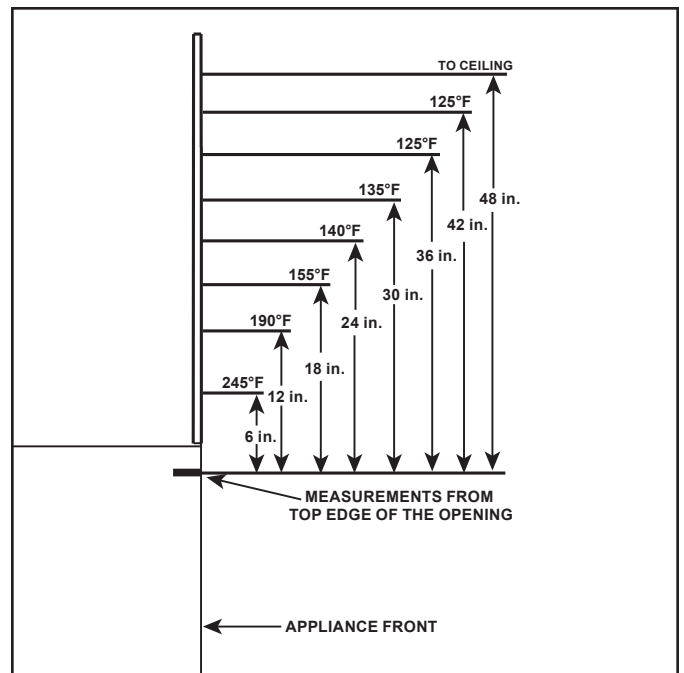


Figure 2.2. Wall Surface Temperatures Above Appliance (GRAVE7260/CRAVE7260ST/CRAVE8472/CRAVE8472ST)

**NOTICE:** Temperatures listed above are taken with a temperature measuring probe as prescribed by the test standard used for appliance certification. Temperatures on walls or mantels taken with an infrared thermometer may yield increased temperatures of up to 30 degrees or more depending on the thermometer settings and material characteristics being measured.

## C. Tools and Supplies Needed

Before beginning the installation be sure that the following tools and building supplies are available.

Tape measure	Framing material
Pliers	Non-corrosive leak check solution
Hammer	Phillips screwdriver
Gloves	Framing square
Voltmeter	Electric drill and bits (1/4 in. magnetic)
Plumb line	Safety glasses
Level	Reciprocating saw
Manometer	Flat blade screwdriver

1/2 - 3/4 in. length, #6 or #8 Self-drilling screws  
Caulking material (300°F minimum continuous exposure rating)

## D. Inspect Appliance and Components

- Carefully remove the appliance and components from the packaging.
- The vent system components and decorative doors and fronts may be shipped in separate packages.
- If packaged separately, the media, refractory, and/or optional log kits must be installed.
- Report to your dealer any parts damaged in shipment, particularly the condition of the glass.
- **Read all of the instructions before starting the installation. Follow these instructions carefully during the installation to ensure maximum safety and benefit.**

***WARNING! Risk of Fire or Explosion! Damaged parts could impair safe operation. DO NOT install damaged, incomplete or substitute components. Keep appliance dry.***

Hearth & Home Technologies disclaims any responsibility for, and the warranty will be voided by, the following actions:

- Installation and use of any damaged appliance or vent system component.
- Modification of the appliance or vent system.
- Installation other than as instructed by Hearth & Home Technologies.
- Improper positioning of the gas logs or the glass door.
- Installation and/or use of any component part not approved by Hearth & Home Technologies.

**Any such action may cause a fire hazard.**

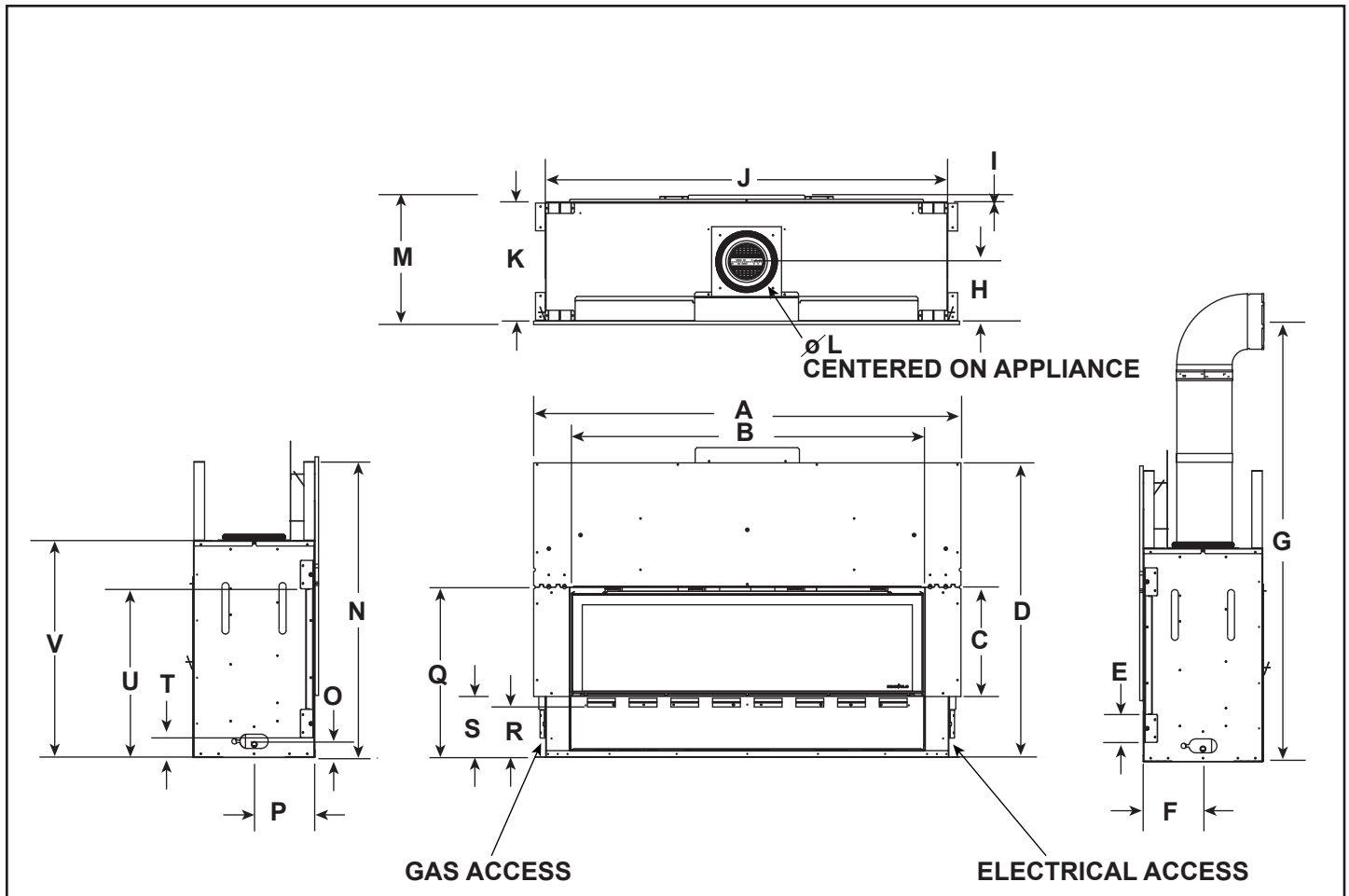
***WARNING! Risk of Fire, Explosion or Electric Shock! DO NOT use this appliance if any part has been under water. Call a qualified service technician to inspect the appliance and to replace any part of the control system and/or gas control which has been under water.***



# 3 Framing and Clearances

## A. Appliance/Decorative Front Dimension Diagrams

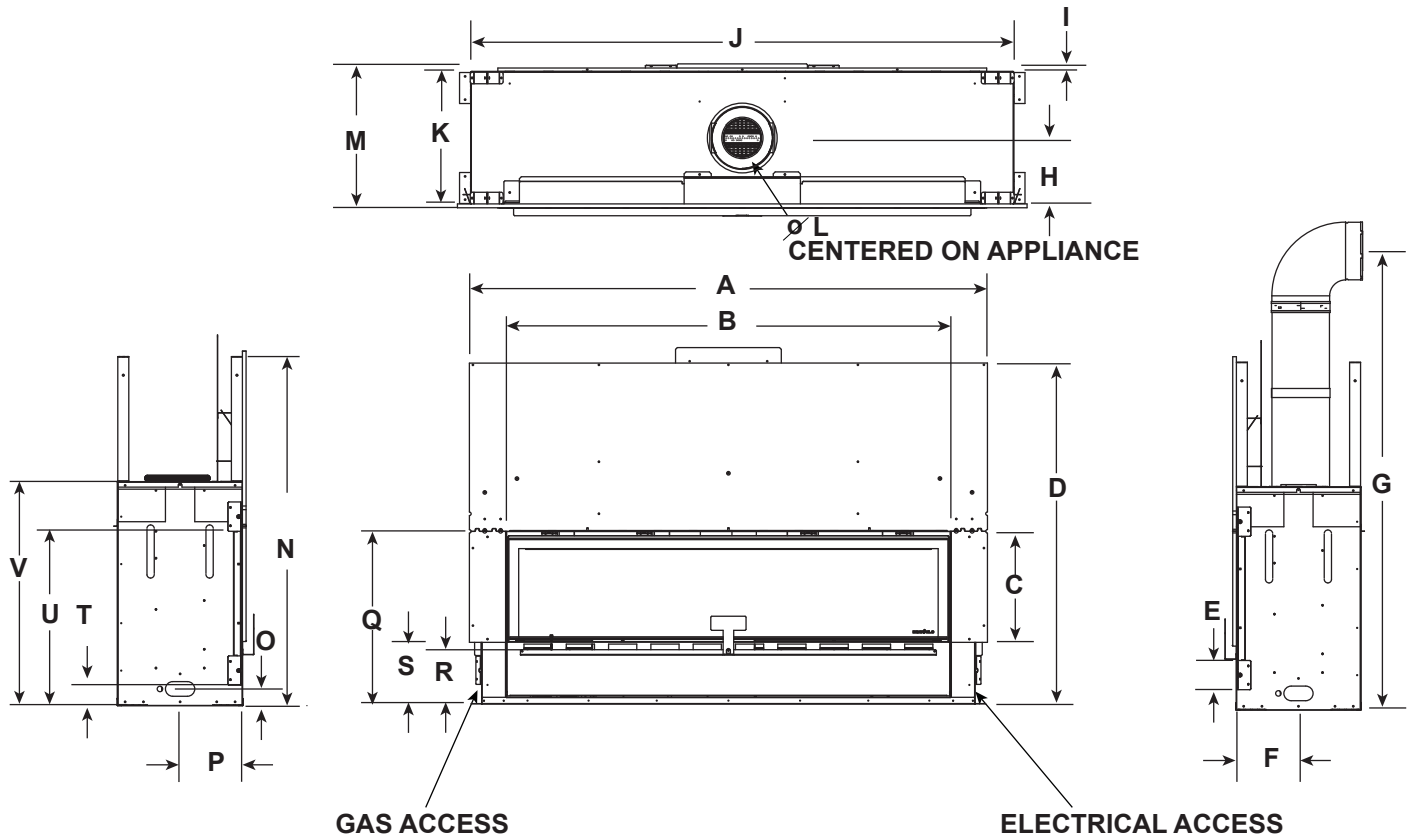
Dimensions are actual appliance dimensions. Use for reference only. For framing dimensions and clearances refer to Section 5.



Location	CRAVE4836		CRAVE6048	
	Inches	Millimeters	Inches	Millimeters
A	50	1270	62	1575
B	39-1/4	997	51-1/8	1299
C	15-5/8	397	15-5/8	397
D	42-1/2	1080	42-1/2	1080
E	4	102	4	102
F	8-9/16	217	8-9/16	217
G	63	1600	63	1600
H	8-9/16	217	8-9/16	217
I	1	25	1	25
J	46-3/16	1173	58	1473
K	17-1/8	435	17-1/8	435

Location	CRAVE4836		CRAVE6048	
	Inches	Millimeters	Inches	Millimeters
L	8	203	8	203
M	18-5/8	471	18-5/8	471
N	41-3/4	1060	41-3/4	1060
O	2-3/8	60	2-3/8	60
P	8-9/16	217	8-9/16	217
Q	24-1/2	622	24-1/2	622
R	7-1/4	184	7-1/4	184
S	8-7/8	225	8-7/8	225
T	2-3/4	70	2-3/4	70
U	23-3/4	603	23-3/4	603
V	30-1/2	775	30-1/2	775

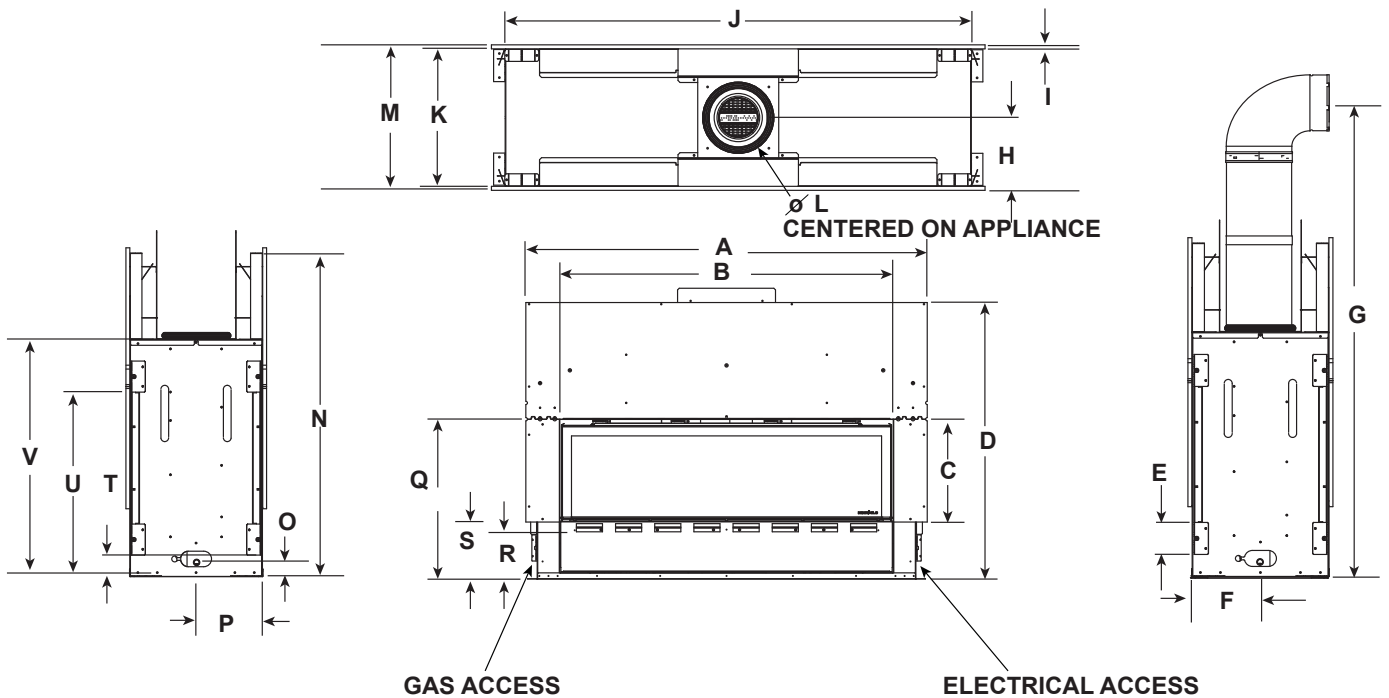
Figure 3.1 Appliance Dimensions - CRAVE4836,CRAVE6048



Location	CRAVE7260		CRAVE8472	
	Inches	Millimeters	Inches	Millimeters
A	74	1880	86	2184
B	63-1/8	1603	75-1/8	1908
C	15-5/8	397	15-5/8	397
D	48-1/2	1232	48-1/2	1232
E	4	102	4	102
F	8-9/16	217	8-9/16	217
G	63	1600	75	1905
H	8-9/16	217	8-9/16	217
I	1	25	1	25
J	70	1778	82	2083
K	17-1/8	435	17-1/8	435

Location	CRAVE7260		CRAVE8472	
	Inches	Millimeters	Inches	Millimeters
L	8	203	8	203
M	18-5/8	471	18-5/8	471
N	47-3/4	1213	47-3/4	1213
O	2-3/8	60	2-3/8	60
P	8-9/16	217	8-9/16	217
Q	24-1/2	622	24-1/2	622
R	7-1/4	184	7-1/4	184
S	8-7/8	225	8-7/8	225
T	2-3/4	70	2-3/4	70
U	23-3/4	603	23-3/4	603
V	30-1/2	775	30-1/2	775

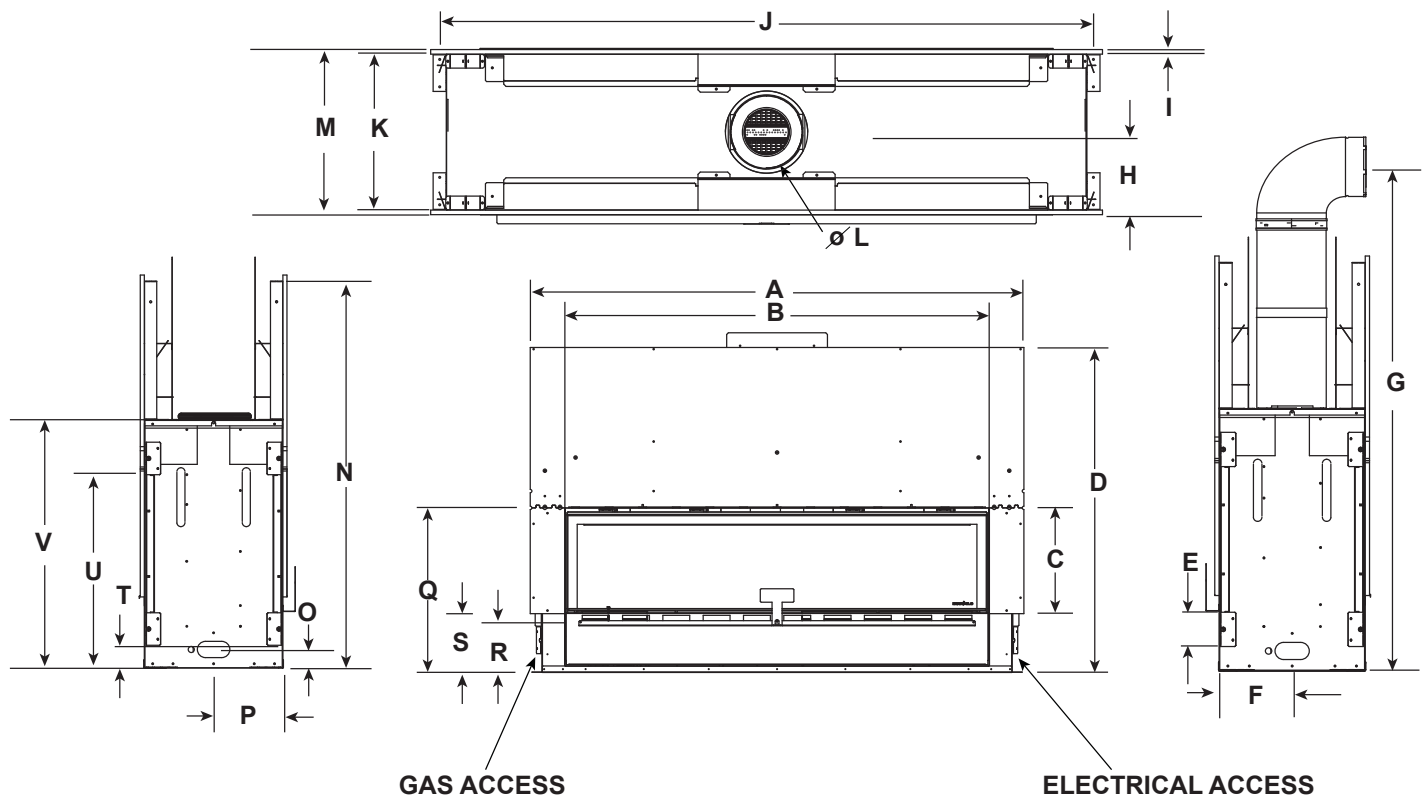
Figure 3.2 Appliance Dimensions - CRAVE7260, CRAVE8472



Location	CRAVE4836ST		CRAVE6048ST	
	Inches	Millimeters	Inches	Millimeters
A	50	1270	62	1575
B	39-1/4	997	51-1/8	1299
C	15-5/8	397	15-5/8	397
D	42-1/2	1080	42-1/2	1080
E	4	102	4	102
F	8-9/16	217	8-9/16	217
G	63	1600	63	1600
H	8-9/16	217	8-9/16	217
I	1/2	13	1/2	13
J	46-3/16	1173	58	1473
K	17-1/8	435	17-1/8	435

Location	CRAVE4836ST		CRAVE6048ST	
	Inches	Millimeters	Inches	Millimeters
L	8	203	8	203
M	18-1/8	460	18-1/8	460
N	41-3/4	1060	41-3/4	1060
O	2-3/8	60	2-3/8	60
P	8-9/16	217	8-9/16	217
Q	24-1/2	622	24-1/2	622
R	7-1/4	184	7-1/4	184
S	8-7/8	225	8-7/8	225
T	2-3/4	70	2-3/4	70
U	23-3/4	603	23-3/4	603
V	30-1/2	775	30-1/2	775

Figure 3.3 Appliance Dimensions - CRAVE4836ST, CRAVE6048ST



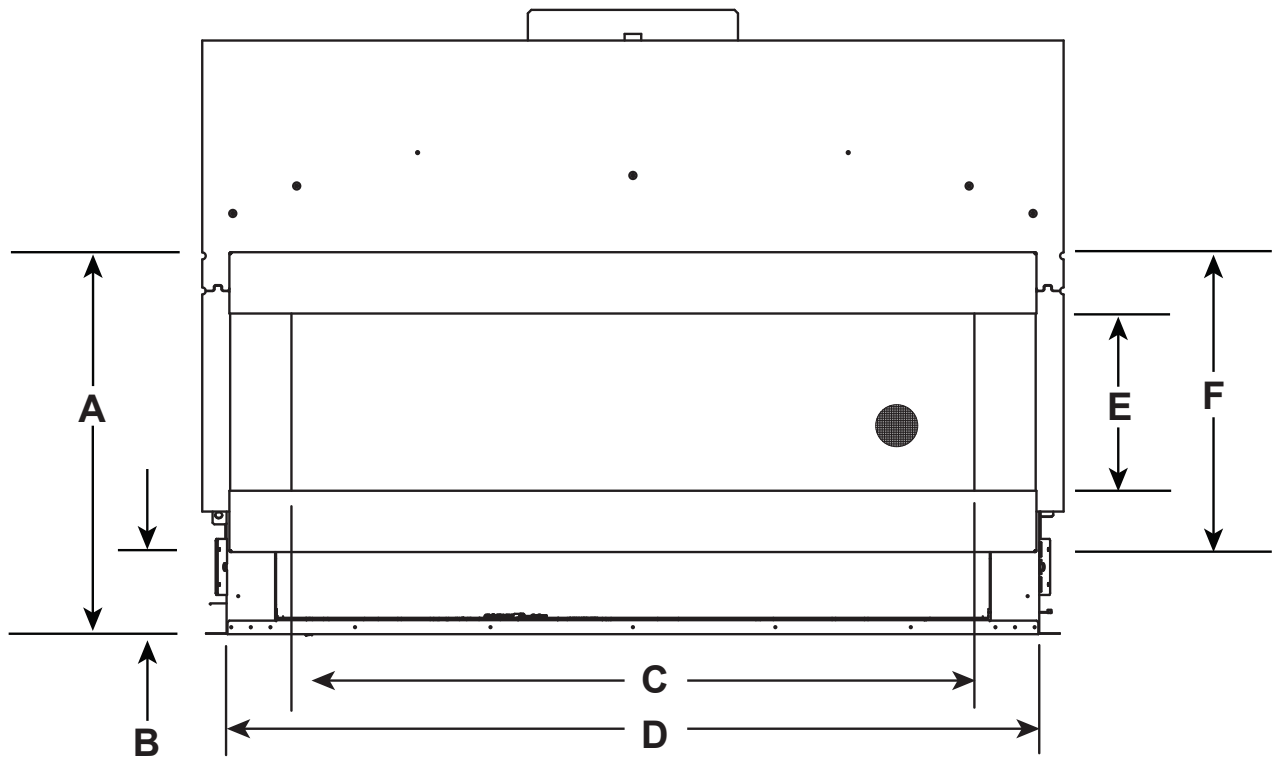
Location	CRAVE7260ST		CRAVE8472ST	
	Inches	Millimeters	Inches	Millimeters
A	74	1880	86	2184
B	63-1/8	1603	75-1/8	1908
C	15-5/8	397	15-5/8	397
D	48-1/2	1232	48-1/2	1232
E	4	102	4	102
F	8-9/16	217	8-9/16	217
G	63	1600	75	1905
H	8-9/16	217	8-9/16	217
I	1/2	13	1/2	13
J	70	1778	82	2083
K	17-1/8	435	17-1/8	435

Location	CRAVE7260ST		CRAVE8472ST	
	Inches	Millimeters	Inches	Millimeters
L	8	203	8	203
M	18-1/8	460	18-1/8	460
N	47-3/4	1213	47-3/4	1213
O	2-3/8	60	2-3/8	60
P	8-9/16	217	8-9/16	217
Q	24-1/2	622	24-1/2	622
R	7-1/4	184	7-1/4	184
S	8-7/8	225	8-7/8	225
T	2-3/4	70	2-3/4	70
U	23-3/4	603	23-3/4	603
V	30-1/2	775	30-1/2	775

Figure 3.4 Appliance Dimensions - CRAVE7260ST, CRAVE8472ST

# FOUR SQUARE DECORATIVE FRONT

Note: See Section 10 for hearth, mantel and finishing requirements.



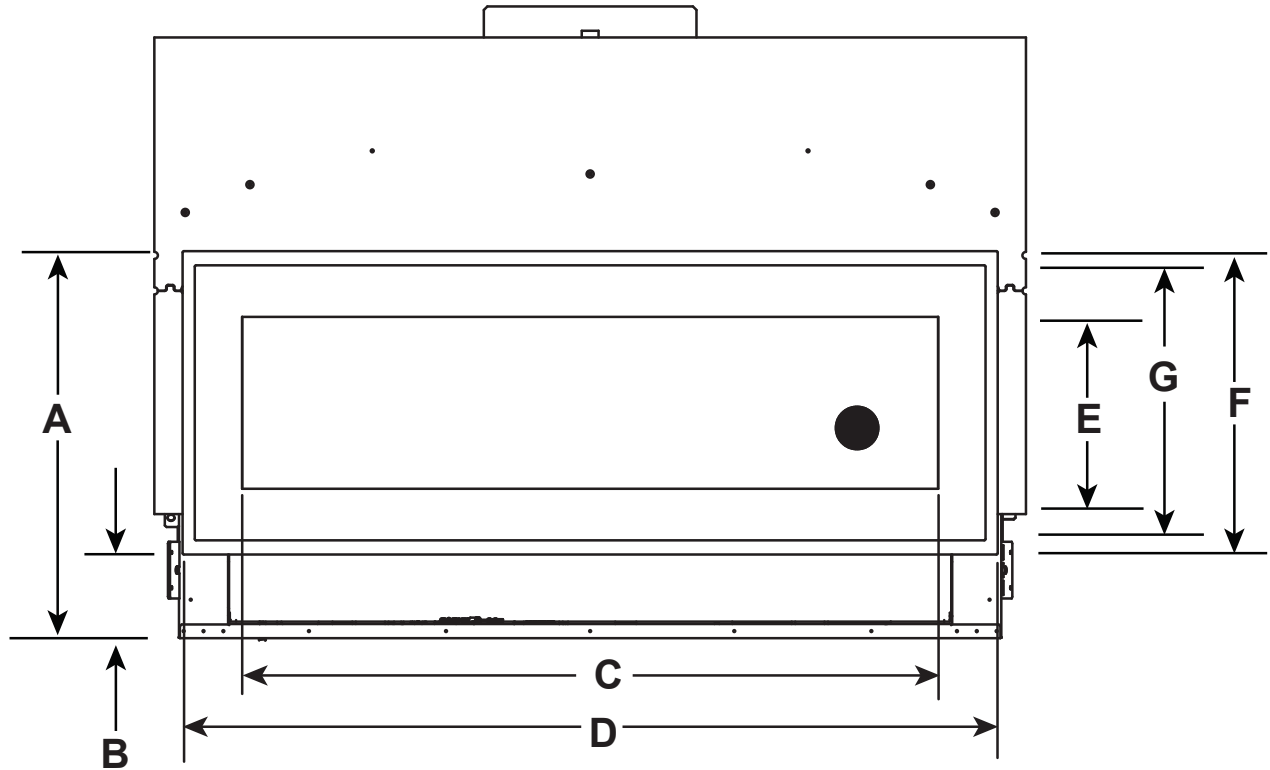
Location	CRAVE4836		CRAVE6048		CRAVE7260	
	Inches	Millimeters	Inches	Millimeters	Inches	Millimeters
A	27-5/16	692	27-5/16	692	27-5/16	692
B	5-7/8	149	5-7/8	149	5-7/8	149
C	36-3/4	933	48-3/4	1238	60-3/4	1543
D	45-5/8	1159	57-5/8	1463	69-5/8	1769
E	12-5/8	321	12-5/8	321	12-5/8	321
F	21-3/8	543	21-3/8	543	21-3/8	543

The Four Square decorative front has an installed depth of 2-1/8 in. (54 mm), measured from the front of the non-combustible finishing material to the front of the decorative front.

Figure 3.5 Four Square (Overlap Fit) Decorative Front Dimensions

# ILLUSION DECORATIVE FRONTS

Note: See Section 10 for hearth, mantel and finishing requirements.



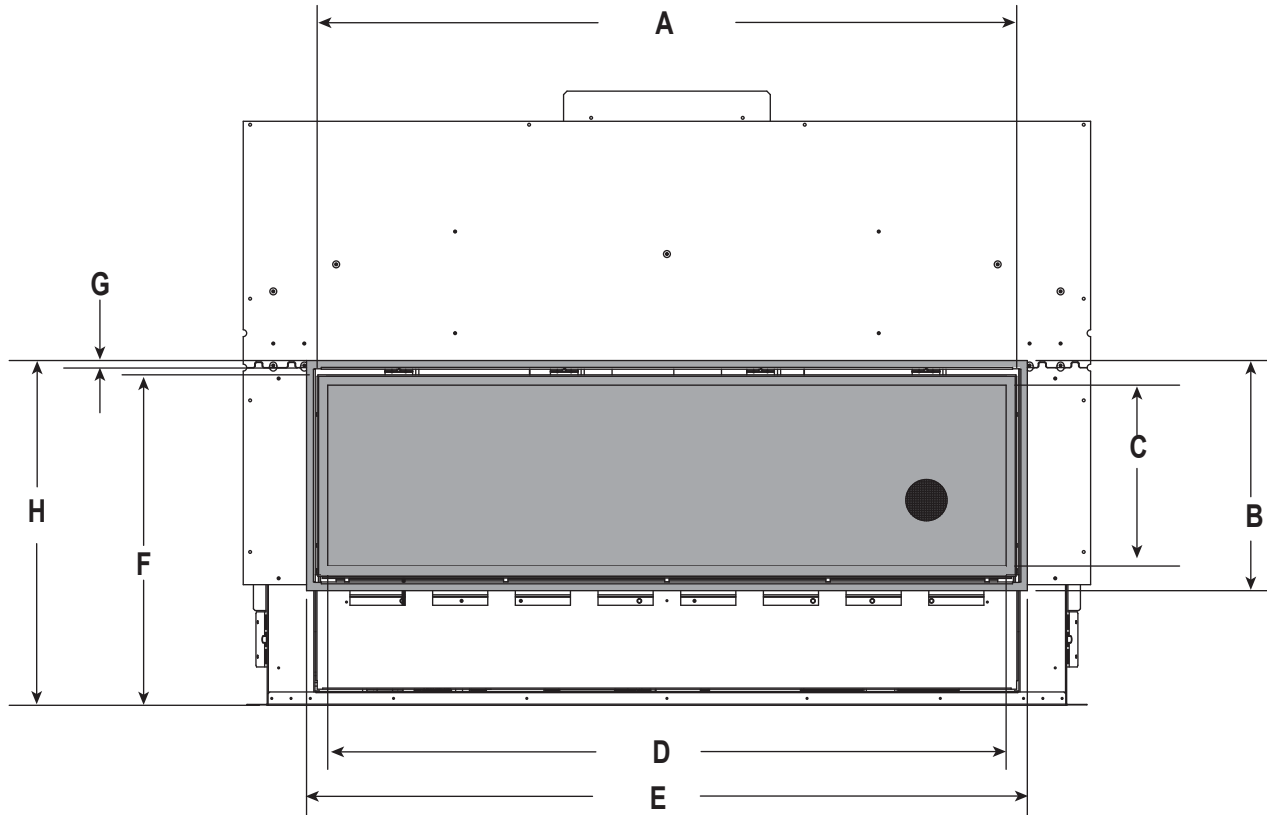
Location	CRAVE4836		CRAVE6048		CRAVE7260	
	Inches	Millimeters	Inches	Millimeters	Inches	Millimeters
A	27-5/16	694	27-5/16	694	27-5/16	692
B	5-7/8	149	5-7/8	149	5-7/8	149
C	37-3/16	945	49-1/8	1248	61-1/8	1553
D	45-1/2	1156	57-1/2	1461	69-1/2	1765
E	12-1/8	308	12-1/8	308	12-1/8	308
F	21-3/8	543	21-3/8	543	21-3/8	543
G	19-7/16	494	19-7/16	494	19-7/16	494

The Illusion decorative front has an installed depth of 2-1/2 in. (64 mm), measured from the front of the non-combustible finishing material to the front of the decorative front.

Figure 3.6 Illusion Decorative Front Dimensions

# CLEAN FACE TRIM DECORATIVE FRONT

Note: See Section 10 for hearth, mantel and finishing requirements.



Location	CRAVE4836		CRAVE6048		CRAVE7260		CRAVE8472	
	Inches	Millimeters	Inches	Millimeters	Inches	Millimeters	Inches	Millimeters
A	39	991	51	1295	63	1600	75	1905
B	16-3/4	425	16-3/4	425	16-3/4	425	16-3/4	425
C	13-1/8	333	13-1/8	333	13-1/8	333	13-1/8	333
D	37-3/16	945	49-3/16	1249	61-3/16	1554	73-3/16	1859
E	40-5/16	1024	52-5/16	1329	64-5/16	1634	76-5/16	1938
F	24	610	24	610	24	610	24	610
G	5/8	16	5/8	16	5/8	16	5/8	16
H	25	635	25	635	25	635	25	635

Figure 3.7 Clean Face Trim Front (Inside Fit) Decorative Front Dimensions

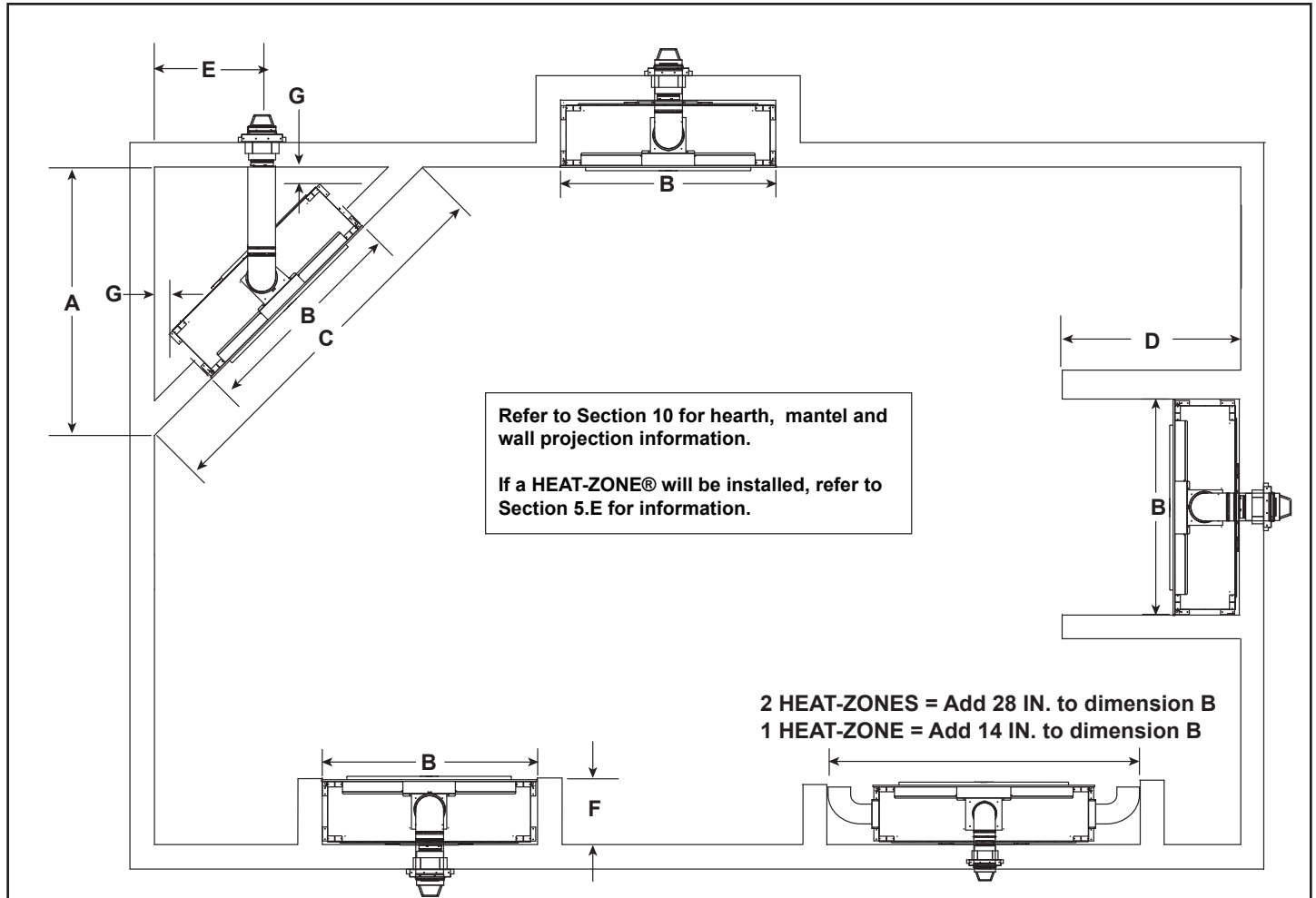
## B. Clearances to Combustibles

When selecting a location for the appliance it is important to consider the required clearances to walls. See Figure 3.8 and Figure 3.9.

**WARNING! Risk of Fire or Burns!** Provide adequate clearance around air openings and for service access. Due to high temperatures, the appliance should be located out of traffic and away from furniture and draperies.

**NOTICE:** Illustrations reflect typical installations and are FOR DESIGN PURPOSES ONLY. Illustrations/diagrams are not drawn to scale. Actual installation could vary due to individual design preference.

It is important to follow the framing and finishing instructions step by step to ensure proper placement of fireplace in the surrounding framing/finishing materials.



Model		A	B	C	D	E	F	G
CRAVE4836	Inches	62-1/2	48-1/4	88-1/8	See Section 10, Figure 10.14 and 10.15.	24-1/2	18-3/4	1
	Millimeters	1588	1226	2239		622	477	25
CRAVE6048	Inches	70-3/4	60-1/4	100-3/8		28-1/2	18-3/4	1
	Millimeters	1797	1530	2550		724	477	25
CRAVE7260	Inches	79-1/2	72-1/4	112-3/8		31-3/4	18-3/4	1
	Millimeters	2019	2013	2854		807	476	25
CRAVE8472	Inches	88	84-1/4	124-3/8		35-1/4	18-3/4	1
	Millimeters	2235	2140	3159		895	476	25

Figure 3.8 Appliance Locations: CRAVE Single-Sided Models



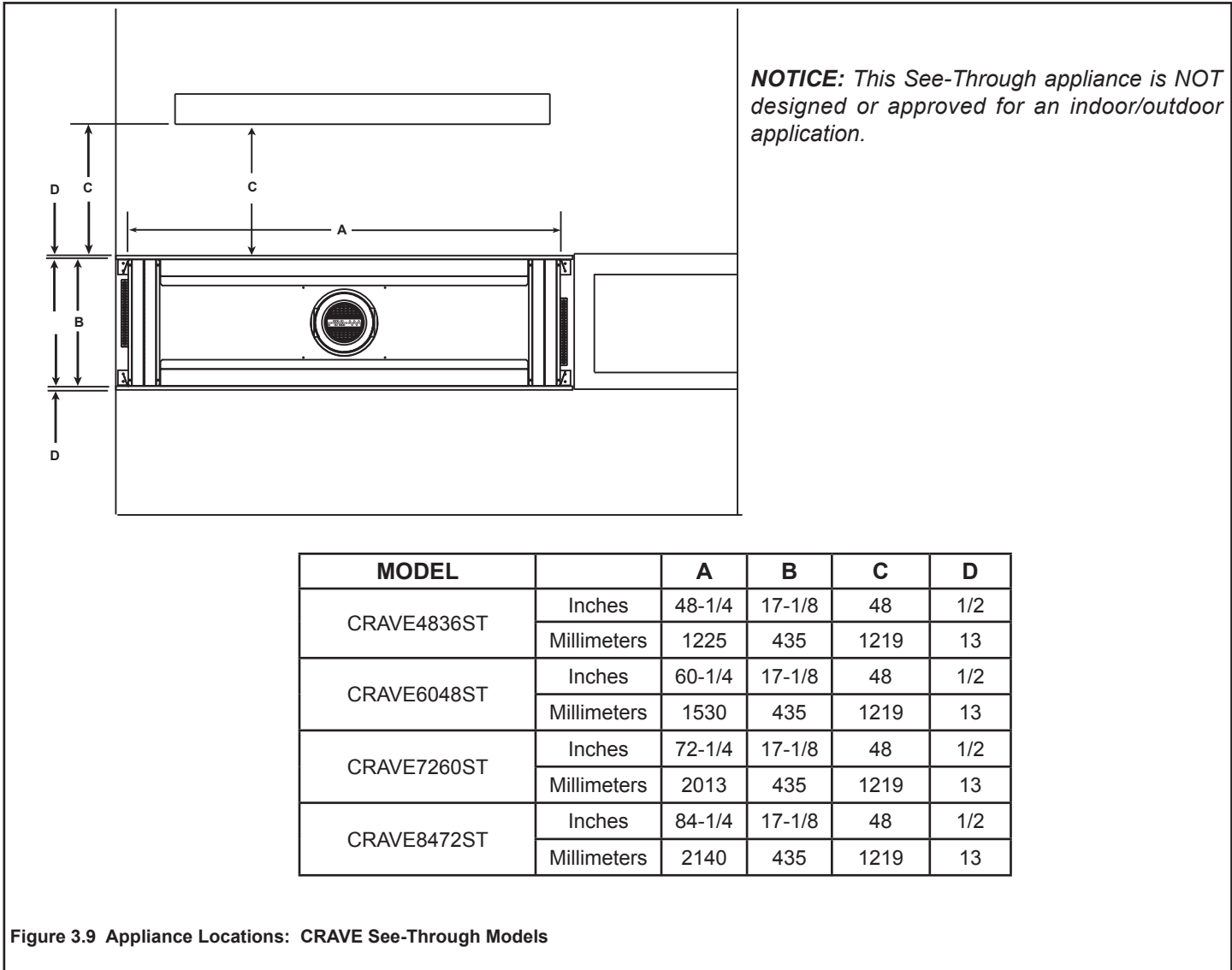


Figure 3.9 Appliance Locations: CRAVE See-Through Models

### C. Constructing the Appliance Chase

A chase is a vertical box-like structure built to enclose the gas appliance and/or its vent system. In cooler climates the vent should be enclosed inside the chase.

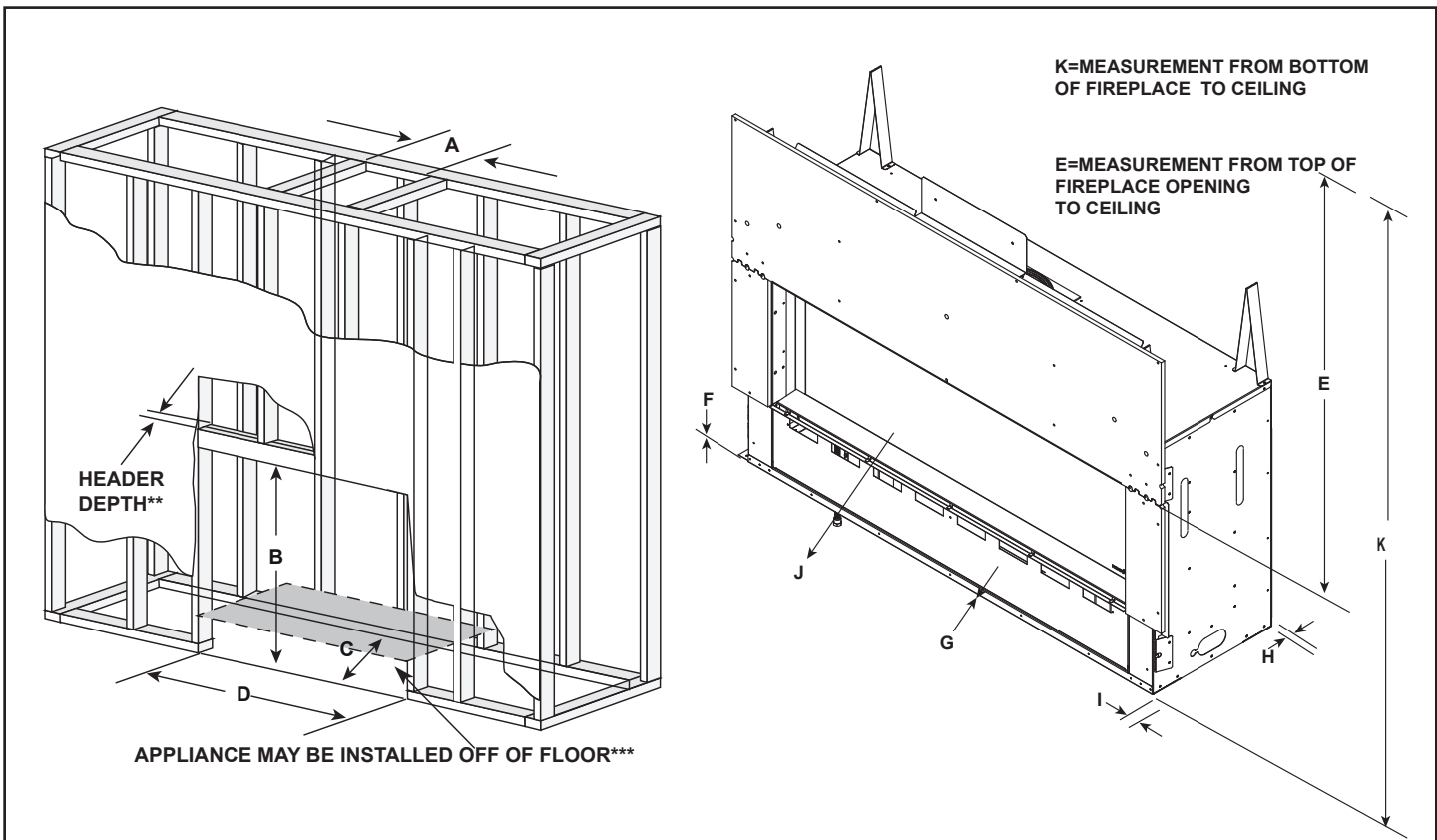
**NOTICE:** Treatment of ceiling firestops and wall shield firestops and construction of the chase may vary with the type of building. These instructions are not substitutes for the requirements of local building codes. Therefore, you **MUST** check local building codes to determine the requirements to these steps.

Chases should be constructed in the manner of all outside walls of the home to prevent cold air drafting problems. The chase should not break the outside building envelope in any manner.

Walls, ceiling, base plate and cantilever floor of the chase should be insulated. Vapor and air infiltration barriers should be installed in the chase as per regional codes for the rest of the home. Additionally, in regions where cold air infiltration may be an issue, the inside surfaces may be sheetrocked and taped (or an equivalent method may be used) to achieve maximum air tightness.

To further prevent drafts, the wall shield and ceiling firestops should be caulked with caulk with a minimum of 300°F continuous exposure rating to seal gaps. Gas line holes and other openings should be caulked with caulk with a minimum of 300°F continuous exposure rating or stuffed with unfaced insulation. If the appliance is being installed on a cement surface, a layer of plywood may be placed underneath to prevent conducting cold up into the room.

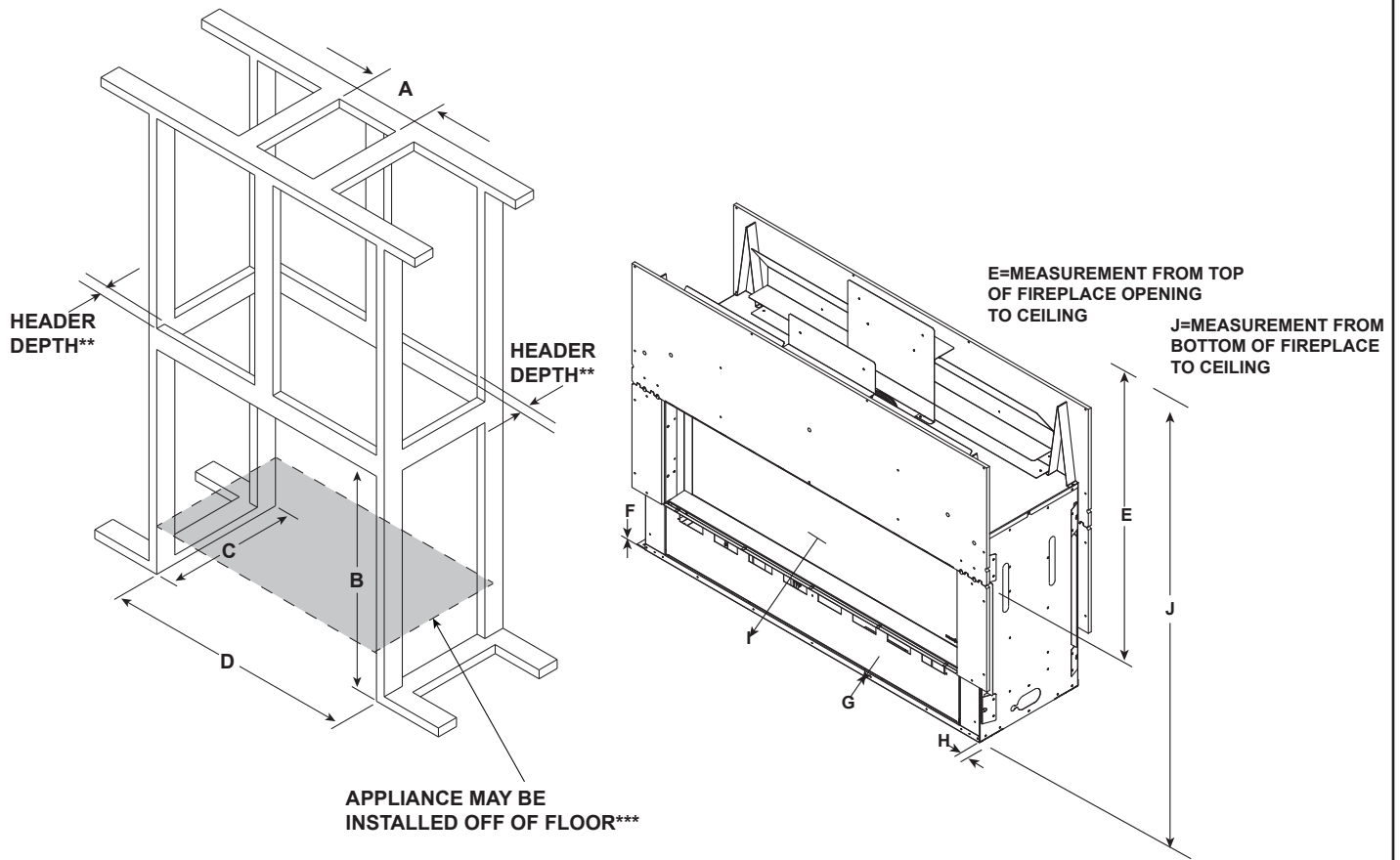
**Note:** Figure 3.10 and Figure 3.11, and Figure 3.12 show the fireplace installed on the floor. However, this fireplace can be elevated off the floor provided that the fireplace is properly supported by framing materials and the ceiling clearances are maintained.



MINIMUM FRAMING DIMENSIONS*											
	A	B	C	D	E	F	G	H	I	J	K
CRAVE4836	Rough Opening (Vent Pipe)	Rough Opening (Height)	Rough Opening (Depth)	Rough Opening (Width)	Clearance to Ceiling	Combustible Floor	Combustible Flooring	Behind Appliance	Sides of Appliance	Front of Appliance	Clearance to Ceiling
Inches	10	42	18-1/4	48-1/4	31	0	0	1	1	48	55-1/2
Millimeters	254	1067	464	1226	787	0	0	25	25	1219	1410
CRAVE6048											
Inches	10	42	18-1/4	60-1/4	31	0	0	1	1	48	55-1/2
Millimeters	254	1067	464	1530	787	0	0	25	25	1219	1410
CRAVE7260											
Inches	10	48	18-1/4	72-1/4	31	0	0	1	1	48	55-1/2
Millimeters	254	1219	464	1835	787	0	0	25	25	1219	1410
CRAVE8472											
Inches	10	48	18-1/4	84-1/4	31	0	0	1	1	48	55-1/2
Millimeters	254	1219	464	2140	787	0	0	25	25	1219	1410

\* = Adjust framing dimensions for interior sheathing (such as sheetrock)  
 \*\*= Header depth not to exceed 3-1/2 inches.  
 \*\*\*= If appliance is installed off of floor, maintain required clearances to combustibles.  
 Construct platform in accordance with local building codes.

Figure 3.10 Clearances to Combustibles-CRAVE4836, CRAVE6048, CRAVE7260, CRAVE8472



MINIMUM FRAMING DIMENSIONS*											
		<b>A</b>	<b>B</b>	<b>C</b>	<b>D</b>	<b>E</b>	<b>F</b>	<b>G</b>	<b>H</b>	<b>I</b>	<b>J</b>
		Rough Opening (Vent Pipe)	Rough Opening (Height)	Rough Opening (Depth)	Rough Opening (Width)	Clearance to Ceiling	Combustible Floor	Combustible Flooring	Sides of Appliance	Front or Rear of Appliance	Clearance to Ceiling
CRAVE4836ST	in.	10	42	17	48-1/4	31	0	0	1	48	55-1/2
	mm	254	1067	432	1226	787	0	0	25	1219	1410
CRAVE6048ST	in.	10	42	17	60-1/4	31	0	0	1	48	55-1/2
	mm	254	1067	432	1530	787	0	0	25	1219	1410
CRAVE7260ST	in.	10	48	17	72-1/4	31	0	0	1	48	55-1/2
	mm	254	1219	432	1835	787	0	0	25	1219	1410
CRAVE8472ST	in.	10	48	17	84-1/4	31	0	0	1	48	55-1/2
	mm	254	1219	432	2140	787	0	0	25	1219	1410

\* = Adjust framing dimensions for interior sheathing (such as sheetrock)

\*\*= Header depth not to exceed 3-1/2 inches.

\*\*\*= If appliance is installed off of floor, maintain required clearances to combustibles.  
Construct platform in accordance with local building codes.

Figure 3.11 Clearances to Combustibles-CRAVE4836ST, CRAVE6048ST, CRAVE7260ST, CRAVE8472ST

## D. Floor Protection

**NOTICE:** Install appliance on hard metal or wood surfaces extending full width and depth. **DO NOT** install directly on carpeting, vinyl, tile or any combustible material other than wood.

**WARNING! Risk of Fire!** Maintain specified air space clearances to appliance and vent pipe:

- Insulation and other materials must be secured to prevent accidental contact.
- The chase must be properly blocked to prevent blown insulation or other combustibles from entering and making contact with fireplace or chimney.
- Failure to maintain airspace could cause overheating and fire.

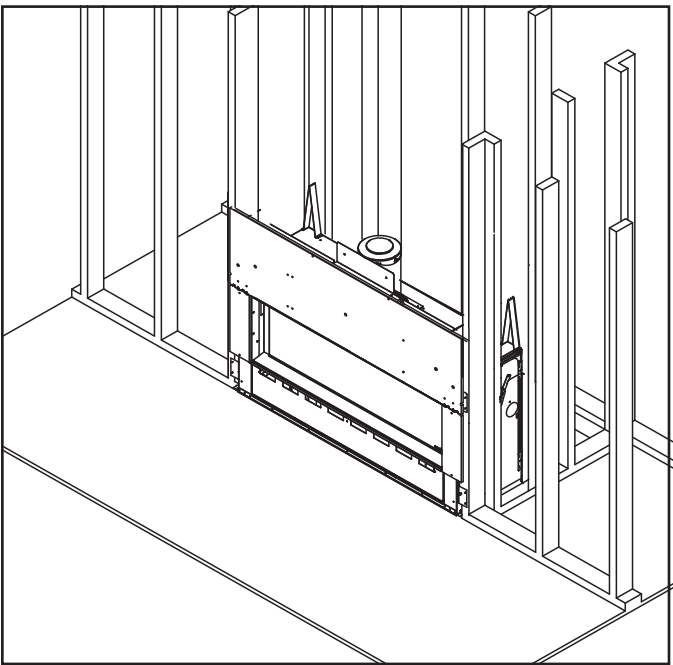


Figure 3.12 Floor Protection

# 4 Termination Location and Vent Information

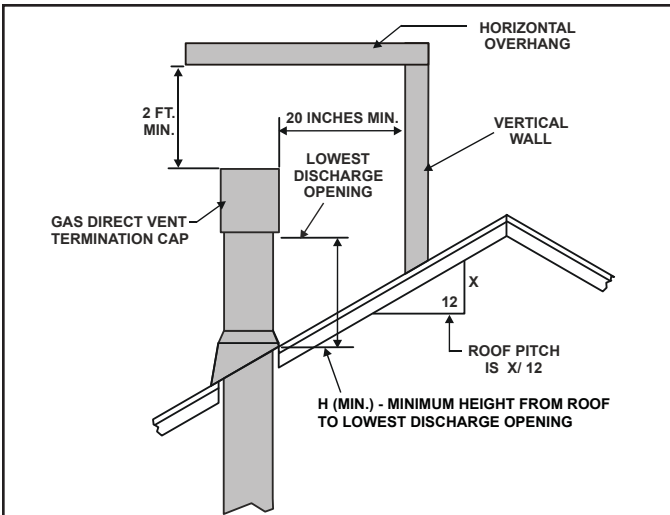
## A. Vent Termination Minimum Clearances

**⚠ WARNING**

Fire Risk.  
Maintain vent clearance to combustibles as specified.

- **DO NOT** pack air space with insulation or other materials.

Failure to keep insulation or other materials away from vent pipe could cause overheating and fire.



Roof Pitch	H (Min.) Ft.
Flat to 6/12.....	1.0*
Over 6/12 to 7/12.....	1.25*
Over 7/12 to 8/12.....	1.5*
Over 8/12 to 9/12.....	2.0*
Over 9/12 to 10/12.....	2.5*
Over 10/12 to 11/12.....	3.25
Over 11/12 to 12/12.....	4.0
Over 12/12 to 14/12.....	5.0
Over 14/12 to 16/12.....	6.0
Over 16/12 to 18/12.....	7.0
Over 18/12 to 20/12.....	7.5
Over 20/12 to 21/12.....	8.0

\* 3 foot minimum in snow regions

**Figure 4.1 Minimum Height From Roof To Lowest Discharge Opening**

A	B
6 in. (minimum) up to 20 in. 152 mm/508 mm	18 in. minimum 457 mm
20 in. and over	0 in. minimum

Gas, Wood or Fuel Oil Termination Cap

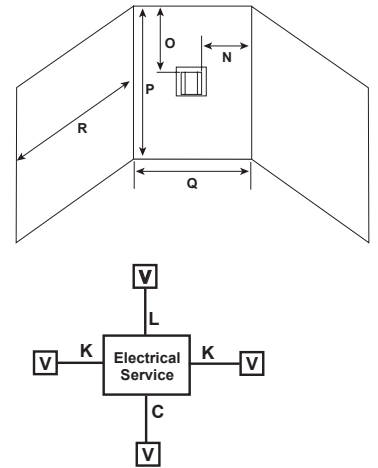
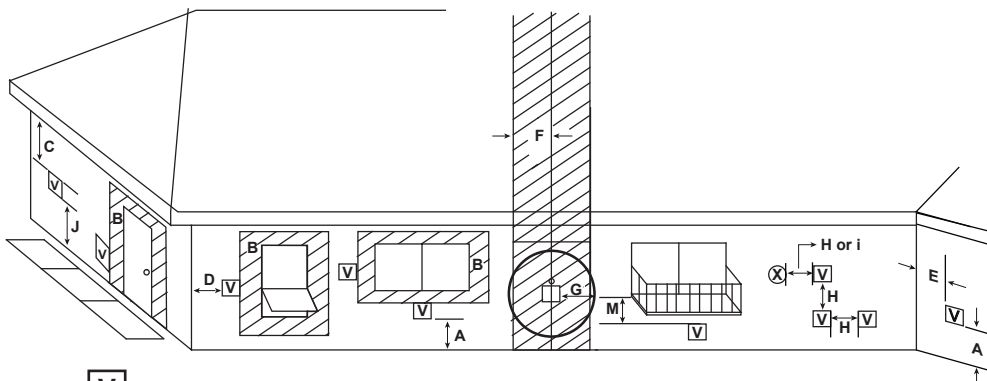
Gas Termination Cap \*\*

\* If using decorative cap cover(s), this distance may need to be increased. Refer to the installation instructions supplied with the decorative cap cover.

\*\* In a staggered installation with both gas and wood or fuel oil terminations, the wood or fuel oil termination cap must be higher than the gas termination cap.

**Figure 4.2 Staggered Termination Caps**

## B. Chimney Diagram



- V** = VENT TERMINAL
- X** = AIR SUPPLY INLET
- = AREA WHERE TERMINAL IS NOT PERMITTED

- A = 12 inches.....clearances above grade, veranda, porch, deck or balcony
- B = 12 inches.....clearance to window or door that may be opened, or to permanently closed window
- C = 18 inches.....clearance below unventilated soffit  
18 inches.....clearance below ventilated soffit  
30 inches.....clearance below vinyl soffits and electrical service

**Vinyl siding shield is required if either vinyl soffits or vinyl siding, or both, are used. See Service Parts List.**

- D = 6 inches.....clearance to outside corner
- E = 6 inches.....clearance to inside corner
- F = 3 ft. (Canada).....not to be installed above a gas meter/regulator assembly within 3 feet horizontally from the center-line of the regulator
- G = 3 ft.....clearance to gas service regulator vent outlet
- H = 9 inches (U.S.A)  
12 inches (Canada).....clearance to non-mechanical (unpowered) air supply inlet, combustion air inlet or direct-vent termination
- i = 3 ft. (U.S.A.)  
6 ft. (Canada).....clearance to a mechanical (powered) air supply inlet

All mechanical air intakes within 10 feet of a termination cap must be a minimum of 3 feet below termination.

- J = 7 ft..... On **public** property: clearance above paved sidewalk or a paved driveway.

A vent shall not terminate directly above a sidewalk or paved driveway which is located between two single family dwellings and serves both dwellings.

- K = 6 inches.....clearance from sides of electrical service
- L = 12 inches.....clearance above electrical service  
Location of the vent termination must not interfere with access to the electrical service.

- M = 18 inches ..... clearance under veranda, porch, deck, balcony or overhang  
42 inches .....vinyl or composite overhang  
Permitted when veranda, porch, deck or balcony is fully open on a minimum of 2 sides beneath the floor.

**Figure 4.3 Minimum Clearances for Termination**

### Covered Alcove Applications

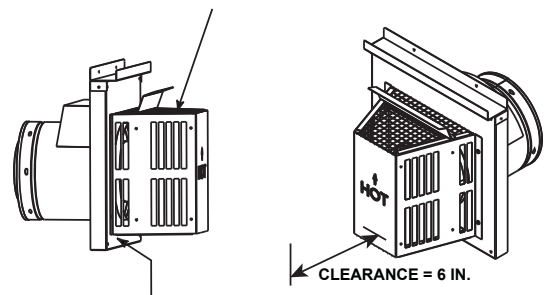
(Spaces open only on one side and with an overhang)

- N = 6 inches ..... non-vinyl sidewalls  
12 inches ..... vinyl sidewalls
- O = 18 inches ..... non-vinyl soffit and overhang  
42 inches ..... vinyl soffit and overhang
- P = 8 ft.

	$Q_{MIN}$	$R_{MAX}$
1 cap	3 feet	2 x $Q_{ACTUAL}$
2 caps	6 feet	1 x $Q_{ACTUAL}$
3 caps	9 feet	2/3 x $Q_{ACTUAL}$
4 caps	12 feet	1/2 x $Q_{ACTUAL}$

$Q_{MIN} = \# \text{ termination caps} \times 3$      $R_{MAX} = (2 / \# \text{ termination caps}) \times Q_{ACTUAL}$

Measure vertical clearances from this surface.



Measure horizontal clearances from this surface.

**CAUTION! Risk of Burns!** Termination caps are **HOT**, consider proximity to doors, traffic areas or where people may pass or gather (sidewalk, deck, patio, etc.). Listed cap shields available. Contact your dealer.

- Local codes or regulations may require different clearances.
- Vent system termination is **NOT** permitted in screened porches.
- Vent system termination is permitted in porch areas with two or more sides open.
- Hearth & Home Technologies assumes no responsibility for the improper performance of the appliance when the venting system does not meet these requirements.
- Vinyl siding shield is required for use with vinyl siding. See Service Parts list for information.

### C. Approved Pipe

This appliance is approved for use with Hearth & Home Technologies DVP venting systems. Refer to Section 12.A for vent component information and dimensions.

**DO NOT** mix pipe, fittings or joining methods from different manufacturers.

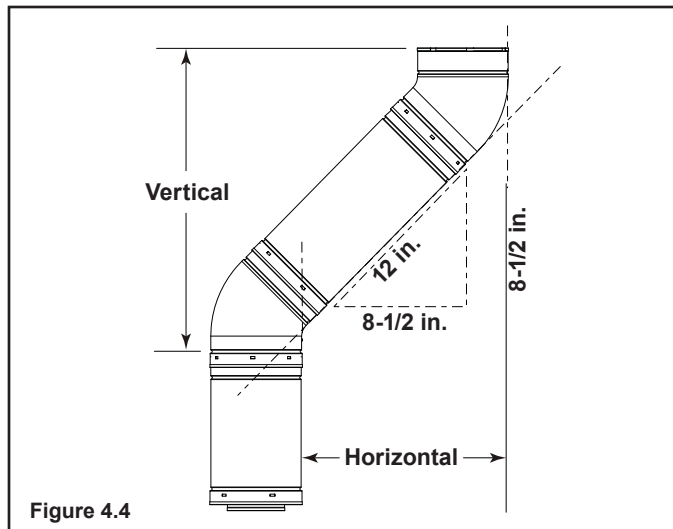
The pipe is tested to be run inside an enclosed wall. There is no requirement for inspection openings at each joint within the wall.

**WARNING! Risk of Fire or Asphyxiation.** This appliance requires a separate vent. **DO NOT** vent to a pipe serving a separate solid fuel burning appliance.

### D. Use of Elbows

Diagonal runs have both vertical and horizontal vent aspects when calculating the effects. Use the rise for the vertical aspect and the run for the horizontal aspect (see Figure 4.4).

Two 45° elbows may be used in place of one 90° elbow. On 45° runs, one foot of diagonal is equal to 8-1/2 in. (216 mm) horizontal run and 8-1/2 in. (216 mm) vertical run. A length of straight pipe is allowed between two 45° elbows. See Figure 4.4.



### E. Measuring Standards

Vertical and horizontal measurements listed in the vent diagrams were made using the following standards:

- Pipe measurements are shown using the effective length of pipe. See Section 12.A for information on effective length of pipe components.
- Measurements are made from the appliance outer wrap, not from the standoffs.
- Horizontal terminations are measured to the outside mounting surface (flange of termination cap). See Figure 4.3.
- Vertical terminations are measured to bottom of termination cap.
- Horizontal pipe installed level with no rise.

### F. Vent Diagrams

General Rules:

- When penetrating a combustible wall, a wall shield firestop must be installed.
- When penetrating a combustible ceiling, a ceiling firestop must be installed.
- Horizontal runs of vent do not require vertical rise; horizontal runs may be level.
- Horizontal termination cap should have a 1/4 inch downward slant to allow any moisture in cap to be released.



## ⚠ WARNING

Fire Risk. Explosion Risk.

Do NOT pack insulation or other combustibles between ceiling firestops.

- ALWAYS maintain specified clearances around venting and firestop systems.
- Install wall shield and ceiling firestops as specified.

Failure to keep insulation or other material away from vent pipe could cause fire.



### Top Vent - Horizontal Termination Venting with 1 elbow

**WARNING! Risk of Fire!**

**DO NOT attach elbow directly to the appliance.**

- The CRAVE4836/CRAVE4836ST, CRAVE6048/CRAVE6048ST and CRAVE7260/CRAVE7260ST require a minimum of 24 inches of vertical venting before attaching any elbow to the appliance.
- The CRAVE8472/CRAVE8472ST requires a minimum of 36 inches of vertical venting before attaching any elbow to the appliance.

CRAVE4836, CRAVE6048, CRAVE7260			
V <sub>1</sub> Minimum		H <sub>1</sub> Maximum	
2 ft.	610 mm	1.5 ft.	457 mm
3 ft.	914 mm	6 ft.	1.8 m
4 ft.	1.2 m	9 ft.	2.7 m
5 ft.	1.5 m	12 ft.	3.7 m
6 ft.	1.8 m	15 ft.	4.6 m
7 ft.	2.1 m	18 ft.	5.5 m
8 ft.	2.4 m	21 ft.	6.4 m
V <sub>1</sub> + H <sub>1</sub> = 63 ft. (19.2 m) Maximum H <sup>1</sup> = 40 ft. (12.2 m) Maximum			

Note: Use DVP Series components only.

CRAVE8472ST			
V <sub>1</sub> Minimum		H <sub>1</sub> Maximum	
3 ft.	914 mm	3-1/2 ft.	1.1 m
4 ft.	1.2 m	6 ft.	1.8 m
5 ft.	1.5 m	9 ft.	2.7 m
6 ft.	1.8 m	12 ft.	3.7 m
7 ft.	2.1 m	15 ft.	4.6 m
8 ft.	2.4 m	18 ft.	5.5 m
9 ft.	2.7 m	21 ft.	6.4 m
V <sub>1</sub> + H <sub>1</sub> = 63 ft. (19.2 m) Maximum H <sup>1</sup> = 40 ft. (12.2 m) Maximum			

CRAVE4836ST, CRAVE6048ST, CRAVE7260ST			
V <sub>1</sub> Minimum		H <sub>1</sub> Maximum	
2 ft.	610 mm	3 ft.	914 mm
3 ft.	914 mm	6 ft.	1.8 m
4 ft.	1.2 m	9 ft.	2.7 m
5 ft.	1.5 m	12 ft.	3.7 m
6 ft.	1.8 m	15 ft.	4.6 m
7 ft.	2.1 m	18 ft.	5.5 m
8 ft.	2.4 m	21 ft.	6.4 m
V <sub>1</sub> + H <sub>1</sub> = 63 ft. (19.2 m) Maximum H <sup>1</sup> = 40 ft. (12.2 m) Maximum			

CRAVE8472			
V <sub>1</sub> Minimum		H <sub>1</sub> Maximum	
3 ft.	914 mm	1-1/2 ft.	457 mm
4 ft.	1.2 m	6 ft.	1.8 m
5 ft.	1.5 m	9 ft.	2.7 m
6 ft.	1.8 m	12 ft.	3.7 m
7 ft.	2.1 m	15 ft.	4.6 m
8 ft.	2.4 m	18 ft.	5.5 m
9 ft.	2.7 m	21 ft.	6.4 m
V <sub>1</sub> + H <sub>1</sub> = 63 ft. (19.2 m) Maximum H <sup>1</sup> = 40 ft. (12.2 m) Maximum			

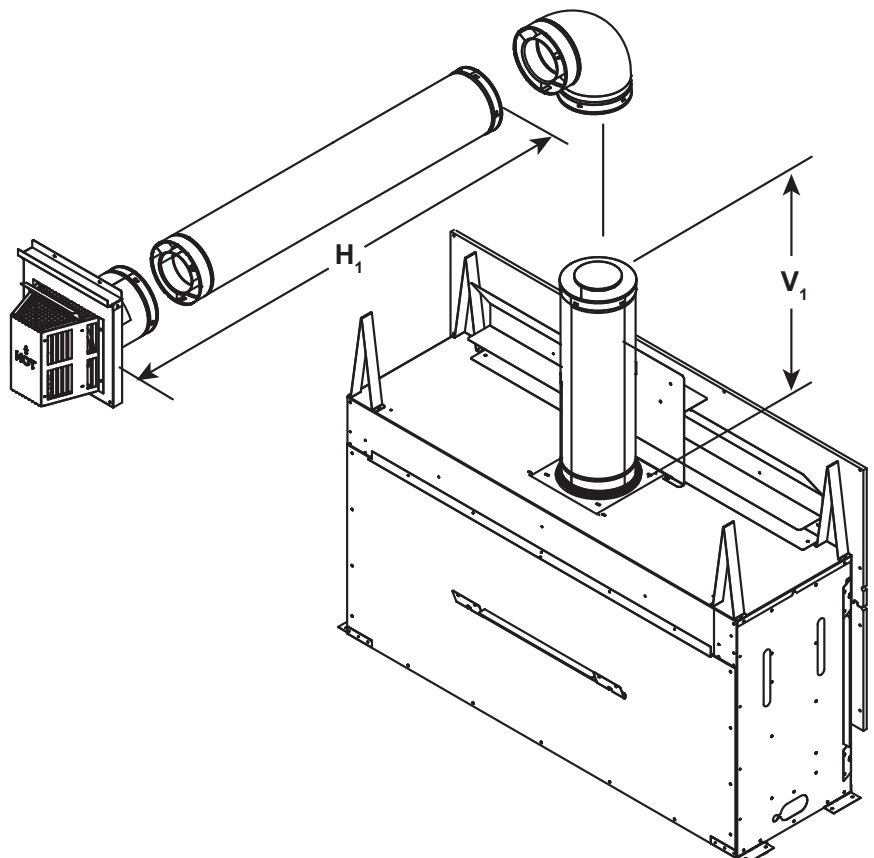


Figure 4.5



## Top Vent - Horizontal Termination Venting with 2 elbows

**WARNING! Risk of Fire!**

**DO NOT attach elbow directly to the appliance.**

- The CRAVE4836/CRAVE4836ST, CRAVE6048/CRAVE6048ST and CRAVE7260/CRAVE7260ST require a minimum of 24 inches of vertical venting before attaching any elbow to the appliance.
- The CRAVE8472/CRAVE8472ST requires a minimum of 36 inches of vertical venting before attaching any elbow to the appliance.

CRAVE4836, CRAVE6048, CRAVE7260			
V <sub>1</sub> Minimum		H <sub>1</sub> + H <sub>2</sub> Maximum	
2 ft.	610 mm	1.5 ft.	457 mm
3 ft.	914 mm	6 ft.	1.8 m
4 ft.	1.2 m	9 ft.	2.7 m
5 ft.	1.5 m	12 ft.	3.7 m
6 ft.	1.8 m	15 ft.	4.6 m
7 ft.	2.1 m	18 ft.	5.5 m
8 ft.	2.4 m	21 ft.	6.4 m
V <sub>1</sub> + H <sub>1</sub> + H <sub>2</sub> = 63 ft. (19.2 m) Maximum H <sub>1</sub> + H <sub>2</sub> = 40 ft. (12.2 m) Maximum			

**Note:** Use DVP Series components only.

CRAVE8472			
V <sub>1</sub> Minimum		H <sub>1</sub> + H <sub>2</sub> Maximum	
3 ft.	914 mm	1-1/2 ft.	457 mm
4 ft.	1.2 m	6 ft.	1.8 m
5 ft.	1.5 m	9 ft.	2.7 m
6 ft.	1.8 m	12 ft.	3.7 m
7 ft.	2.1 m	15 ft.	4.6 m
8 ft.	2.4 m	18 ft.	5.5 m
9 ft.	2.7 m	21 ft.	6.4 m
V <sub>1</sub> + H <sub>1</sub> + H <sub>2</sub> = 63 ft. (19.2 m) Maximum H <sub>1</sub> + H <sub>2</sub> = 40 ft. (12.2 m) Maximum			

CRAVE4836ST, CRAVE6048ST, CRAVE7260ST			
V <sub>1</sub> Minimum		H <sub>1</sub> + H <sub>2</sub> Maximum	
2 ft.	610 mm	3 ft.	914 mm
3 ft.	914 mm	6 ft.	1.8 m
4 ft.	1.2 m	9 ft.	2.7 m
5 ft.	1.5 m	12 ft.	3.7 m
6 ft.	1.8 m	15 ft.	4.6 m
7 ft.	2.1 m	18 ft.	5.5 m
8 ft.	2.4 m	21 ft.	6.4 m
V <sub>1</sub> + H <sub>1</sub> + H <sub>2</sub> = 63 ft. (19.2 m) Maximum H <sub>1</sub> + H <sub>2</sub> = 40 ft. (12.2 m) Maximum			

CRAVE8472ST			
V <sub>1</sub> Minimum		H <sub>1</sub> + H <sub>2</sub> Maximum	
3 ft.	914 mm	3-1/2 ft.	1.1 m
4 ft.	1.2 m	6 ft.	1.8 m
5 ft.	1.5 m	9 ft.	2.7 m
6 ft.	1.8 m	12 ft.	3.7 m
7 ft.	2.1 m	15 ft.	4.6 m
8 ft.	2.4 m	18 ft.	5.5 m
9 ft.	2.7 m	21 ft.	6.4 m
V <sub>1</sub> + H <sub>1</sub> + H <sub>2</sub> = 63 ft. (19.2 m) Maximum H <sub>1</sub> + H <sub>2</sub> = 40 ft. (12.2 m) Maximum			

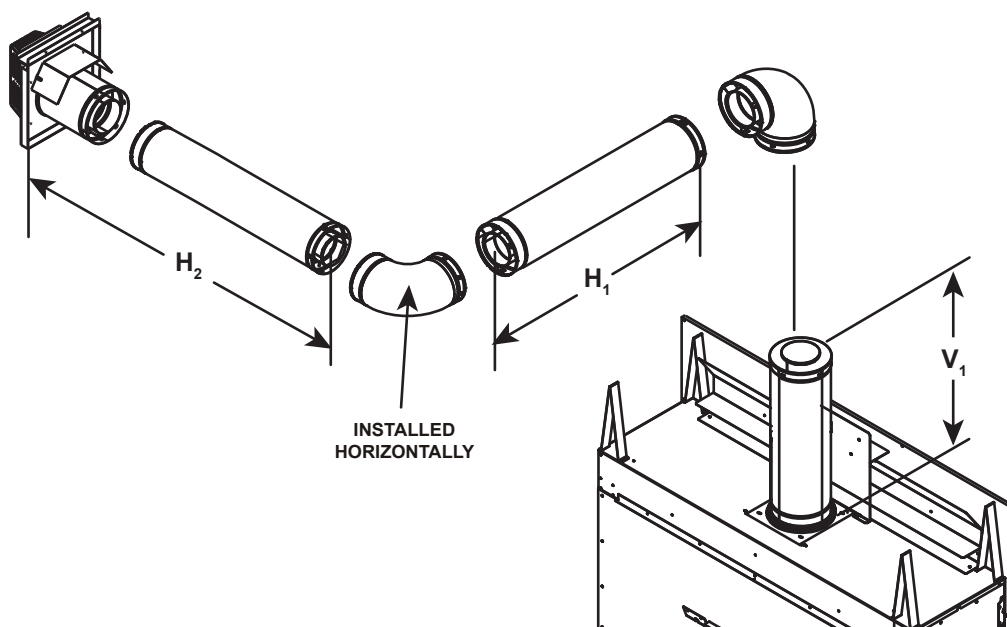


Figure 4.6

## Top Vent - Horizontal Termination Venting with 3 Elbows

**WARNING! Risk of Fire!**

**DO NOT attach elbow directly to the appliance.**

- The CRAVE4836/CRAVE4836ST, CRAVE6048/CRAVE6048ST and CRAVE7260/CRAVE7260ST require a minimum of 24 inches of vertical venting before attaching any elbow to the appliance.
- The CRAVE8472/CRAVE8472ST requires a minimum of 36 inches of vertical venting before attaching any elbow to the appliance.

CRAVE4836, CRAVE6048, CRAVE7260			
V <sub>1</sub> + V <sub>2</sub> Minimum		H <sub>1</sub> + H <sub>2</sub> Maximum	
2 ft.	610 mm	1.5 ft.	457 mm
3 ft.	914 mm	6 ft.	1.8 m
4 ft.	1.2 m	9 ft.	2.7 m
5 ft.	1.5 m	12 ft.	3.7 m
6 ft.	1.8 m	15 ft.	4.6 m
7 ft.	2.1 m	18 ft.	5.5 m
8 ft.	2.4 m	21 ft.	6.4 m
V <sub>1</sub> + V <sub>2</sub> + H <sub>1</sub> + H <sub>2</sub> = 63 ft. (19.2 m) Maximum H <sub>1</sub> + H <sub>2</sub> = 40 ft. (12.2 m) Maximum			

Note: Use DVP Series components only.

CRAVE8472			
V <sub>1</sub> + V <sub>2</sub> Minimum		H <sub>1</sub> + H <sub>2</sub> Maximum	
3 ft.	914 mm	1-1/2 ft.	457 mm
4 ft.	1.2 m	6 ft.	1.8 m
5 ft.	1.5 m	9 ft.	2.7 m
6 ft.	1.8 m	12 ft.	3.7 m
7 ft.	2.1 m	15 ft.	4.6 m
8 ft.	2.4 m	18 ft.	5.5 m
9 ft.	2.7 m	21 ft.	6.4 m
V <sub>1</sub> + V <sub>2</sub> + H <sub>1</sub> + H <sub>2</sub> = 63 ft. (19.2 m) Maximum H <sub>1</sub> + H <sub>2</sub> = 40 ft. (12.2 m) Maximum			

CRAVE4836ST, CRAVE6048ST, CRAVE7260ST			
V <sub>1</sub> + V <sub>2</sub> Minimum		H <sub>1</sub> + H <sub>2</sub> Maximum	
2 ft.	610 mm	3 ft.	914 mm
3 ft.	914 mm	6 ft.	1.8 m
4 ft.	1.2 m	9 ft.	2.7 m
5 ft.	1.5 m	12 ft.	3.7 m
6 ft.	1.8 m	15 ft.	4.6 m
7 ft.	2.1 m	18 ft.	5.5 m
8 ft.	2.4 m	21 ft.	6.4 m
V <sub>1</sub> + V <sub>2</sub> + H <sub>1</sub> + H <sub>2</sub> = 63 ft. (19.2 m) Maximum H <sub>1</sub> + H <sub>2</sub> = 40 ft. (12.2 m) Maximum			

CRAVE8472ST			
V <sub>1</sub> + V <sub>2</sub> Minimum		H <sub>1</sub> + H <sub>2</sub> Maximum	
3 ft.	914 mm	3-1/2 ft.	1.1 m
4 ft.	1.2 m	6 ft.	1.8 m
5 ft.	1.5 m	9 ft.	2.7 m
6 ft.	1.8 m	12 ft.	3.7 m
7 ft.	2.1 m	15 ft.	4.6 m
8 ft.	2.4 m	18 ft.	5.5 m
9 ft.	2.7 m	21 ft.	6.4 m
V <sub>1</sub> + V <sub>2</sub> + H <sub>1</sub> + H <sub>2</sub> = 63 ft. (19.2 m) Maximum H <sub>1</sub> + H <sub>2</sub> = 40 ft. (12.2 m) Maximum			

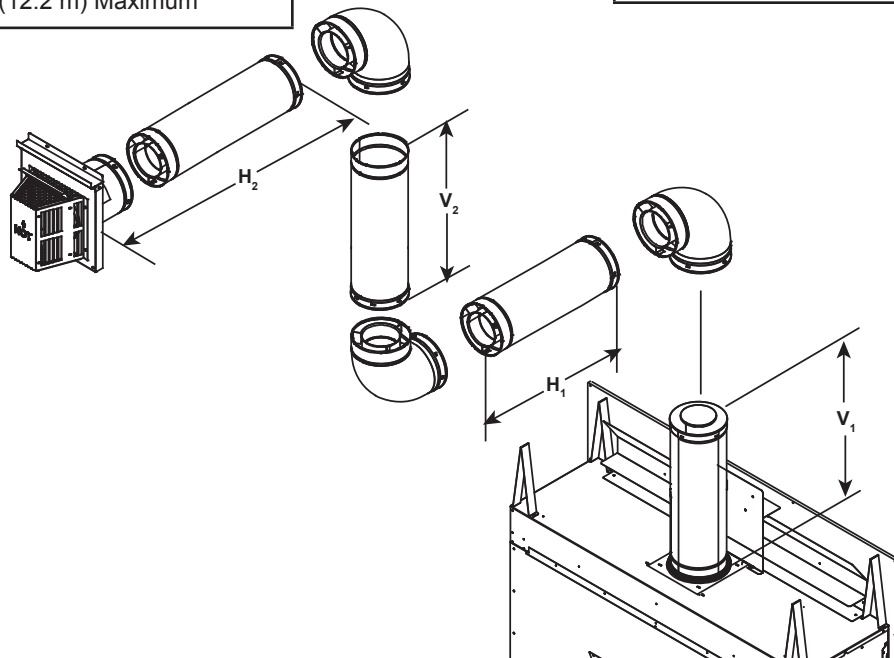


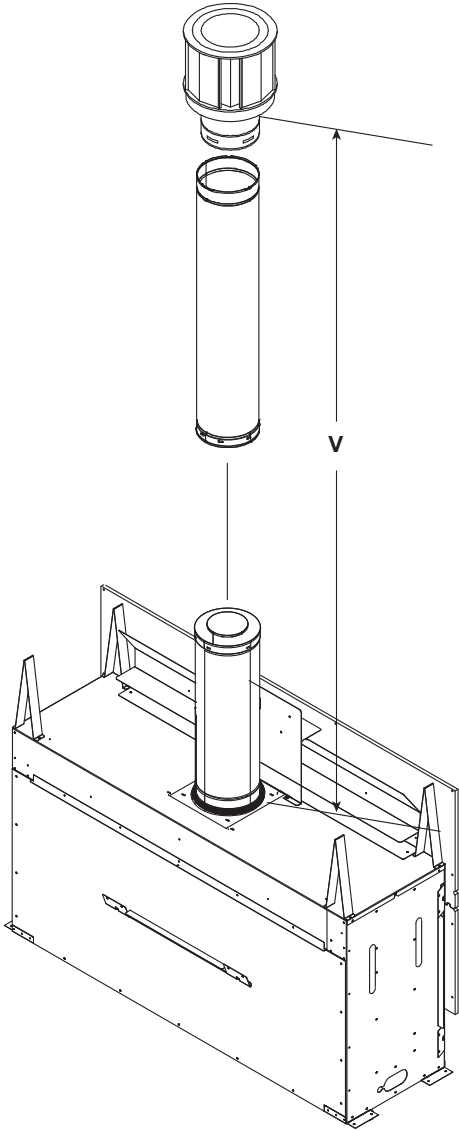
Figure 4.7

**Top Vent - Vertical Termination  
No Elbows**

**V = 3 ft Min. (1m), 50 ft. Max. (15.2 m)**

**Note:** If installing a vertical vent/termination off the top of the appliance, the optional exhaust restrictor may be needed.

**Note:** Use DVP Series components only.



**Figure 4.8 Vertical Vent Maximum**

## Exhaust restrictor Instructions

Exhaust restrictors are recommended for these vertically terminated products which have excessive draft. Exhaust restrictors will compensate for high draft, and restore visual flame height. If the vent configuration has a total vertical of 20-50 feet, an exhaust restrictor may be needed. The exhaust restrictor can be located in the appliance manual bag.

### Exhaust restrictor: CRAVE4836, CRAVE6048, CRAVE7260, CRAVE8472

1. Locate the two pilot holes in the inside firebox chamber as shown in Figure 4.9.
2. Break the flue restrictor into two pieces. Do this by bending the part back and forth until it breaks. See Figure 4.10.
3. The setting for CRAVE4836, CRAVE6048, CRAVE7260 and CRAVE8472 is 2-2. Align the holes marked "2" on the numbered exhaust restrictor piece with the hole on the other exhaust restrictor piece. See Figure 4.11. Align the exhaust restrictor pieces with the pilot holes in the inner firebox chamber. Use two 1/2 inch self-piercing screws to secure vent restrictor to firebox heat shield.
4. In some applications, such as those where the fire-place is elevated off the floor, the exhaust restrictor may be painted, but painting is not required.

**NOTICE:** Before painting, contact your dealer for information on the appropriate high temperature paint.

### Exhaust restrictor: CRAVE4836ST, CRAVE6048ST, CRAVE7260ST, CRAVE8472ST

1. Break the flue restrictor into two pieces. Do this by bending the part back and forth until it breaks. See Figure 4.10.

**Note:** The CRAVE4836ST, CRAVE6048ST, CRAVE7260ST, and CRAVE8472ST do not have pilot holes for the exhaust restrictor in the firebox chamber.

2. The setting for CRAVE4836ST, CRAVE6048ST, CRAVE7260ST, and CRAVE8472ST is a 2.5 inch setting, or 2-2. Align the holes marked "2" on the numbered exhaust restrictor piece with the hole on the other exhaust restrictor piece. See Figure 4.11. Center the exhaust restrictor on the vent and secure in place with two 1/2 inch self-piercing screws.
3. In some applications, such as those where the fire-place is elevated off the floor, the exhaust restrictor may be painted, but painting is not required.

**NOTICE:** Before painting, contact your dealer for information on the appropriate high temperature paint.

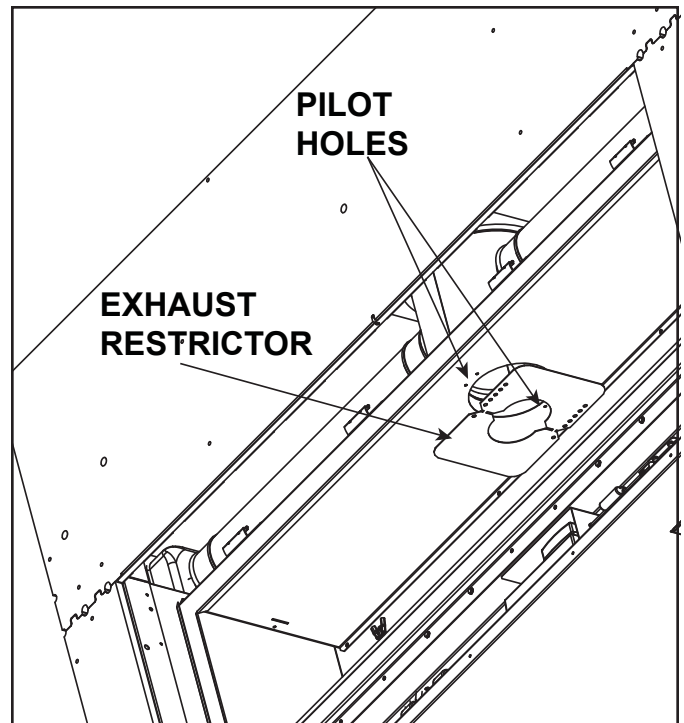


Figure 4.9 Exhaust Restrictor

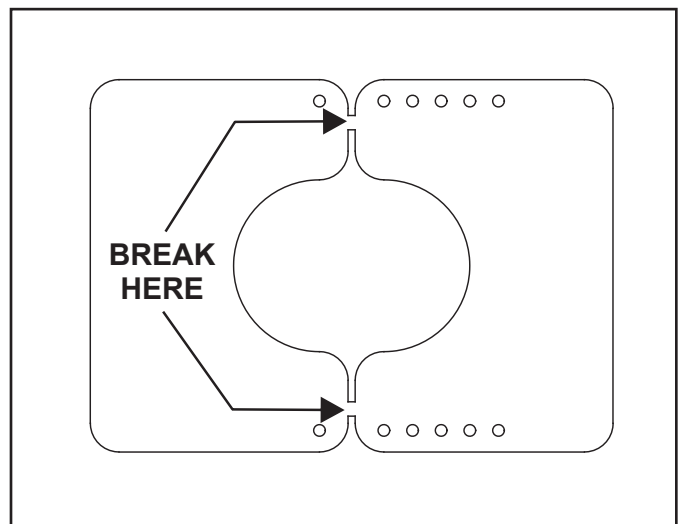


Figure 4.10 Break the Exhaust Restrictor

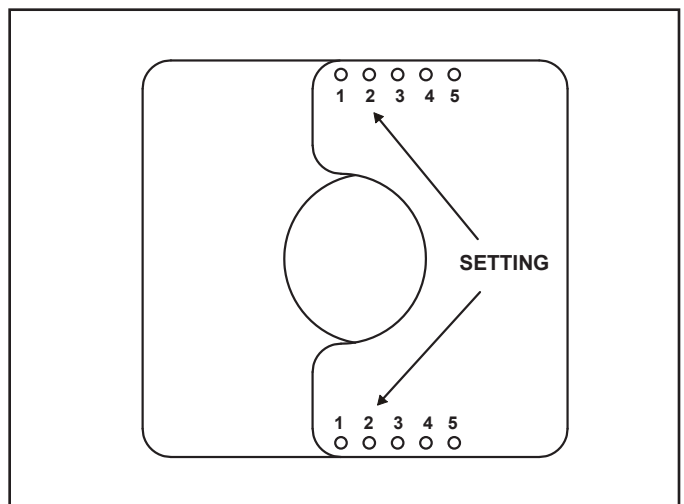


Figure 4.11 Set the Exhaust Restrictor

## Top Vent - Vertical Termination Venting with 2 elbows

**WARNING! Risk of Fire!**

**DO NOT attach elbow directly to the appliance.**

- The CRAVE4836/CRAVE4836ST, CRAVE6048/CRAVE6048ST and CRAVE7260/CRAVE7260ST require a minimum of 24 inches of vertical venting before attaching any elbow to the appliance.
- The CRAVE8472/CRAVE8472ST requires a minimum of 36 inches of vertical venting before attaching any elbow to the appliance.

CRAVE4836, CRAVE6048, CRAVE7260 CRAVE4836ST, CRAVE6048ST, CRAVE7260ST			
V <sub>1</sub> + V <sub>2</sub> Minimum		H Maximum	
2 ft.	610 mm	4 ft.	1.2 m
3 ft.	914 mm	9 ft.	2.7 m
4 ft.	1.2 m	12 ft.	3.6 m
5 ft.	1.5 m	15 ft.	4.5 m
V <sub>1</sub> + H <sub>1</sub> + V <sub>2</sub> = 63 ft. (19.2 m) Maximum H <sub>Total</sub> = 23 ft. (7.1 m) Maximum			

**Note:** Use DVP Series components only.

CRAVE8472, CRAVE8472ST			
V <sub>1</sub> + V <sub>2</sub> Minimum		H Maximum	
3 ft.	914 mm	4 ft.	1.2 m
4 ft.	1.2 m	9 ft.	2.7 m
5 ft.	1.5 m	12 ft.	3.6 m
6 ft.	1.8 m	15 ft.	4.5 m
V <sub>1</sub> + H <sub>1</sub> + V <sub>2</sub> = 63 ft. (19.2 m) Maximum H <sub>Total</sub> = 23 ft. (7.1 m) Maximum			

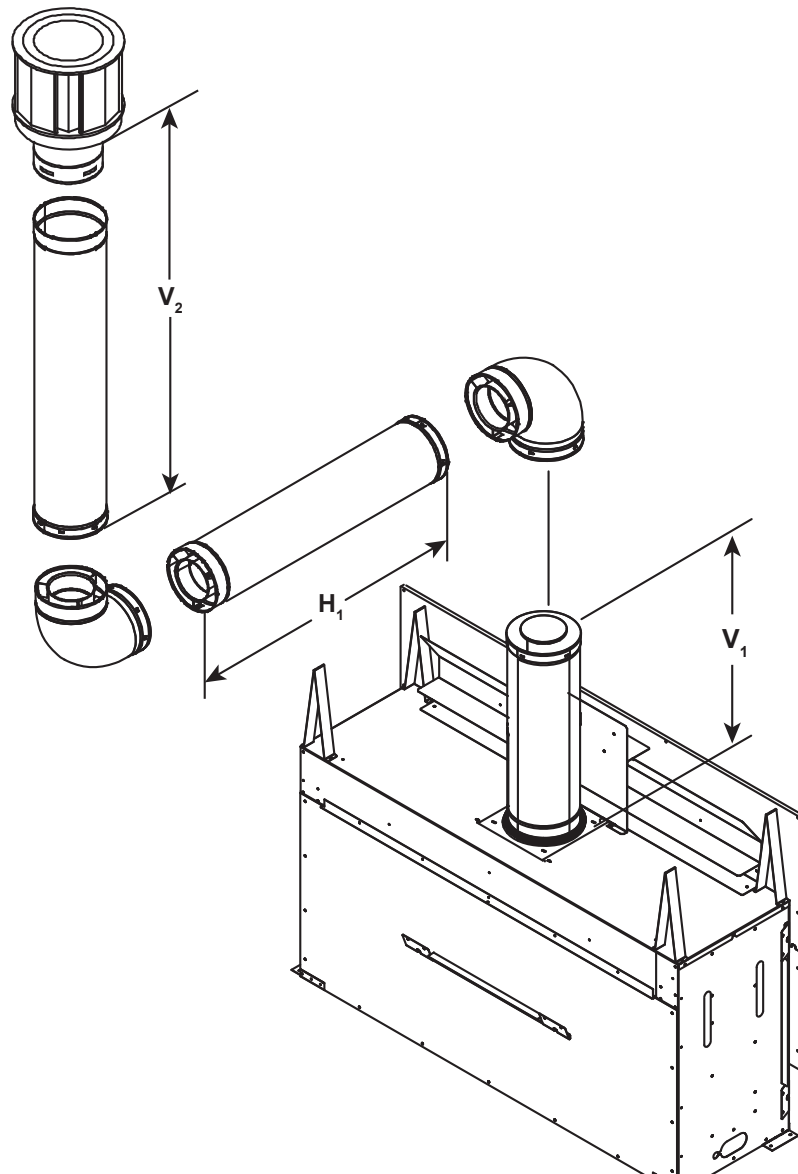


Figure 4.12

## Top Vent - Vertical Termination Venting with 3 elbows

**WARNING! Risk of Fire!**

**DO NOT attach elbow directly to the appliance.**

- The CRAVE4836/CRAVE4836ST, CRAVE6048/CRAVE6048ST and CRAVE7260/CRAVE7260ST require a minimum of 24 inches of vertical venting before attaching any elbow to the appliance.
- The CRAVE8472/CRAVE8472ST requires a minimum of 36 inches of vertical venting before attaching any elbow to the appliance.

CRAVE4836, CRAVE4836ST CRAVE6048, CRAVE6048ST, CRAVE7260, CRAVE7260ST			
$V_1 + V_2$ Minimum		$H_1 + H_2$ Maximum	
2 ft.	610 mm	4 ft.	1.2 m
3 ft.	914 mm	9 ft.	2.7 m
4 ft.	1.2 m	12 ft.	3.6 m
5 ft.	1.5 m	15 ft.	4.5 m
$V_1 + V_2 + H_1 + H_2 = 63$ ft. (19.2 m) Maximum $H_1 + H_2 = 23$ ft. (7.1 m) Maximum			

**Note:** Use DVP Series components only.

CRAVE8472, CRAVE8472ST			
$V_1 + V_2$ Minimum		$H_1 + H_2$ Maximum	
3 ft.	914 mm	4 ft.	1.2 m
4 ft.	1.2 m	9 ft.	2.7 m
5 ft.	1.5 m	12 ft.	3.6 m
6 ft.	1.8 m	15 ft.	4.5 m
$V_1 + V_2 + H_1 + H_2 = 63$ ft. (19.2 m) Maximum $H_1 + H_2 = 23$ ft. (7.1 m) Maximum			

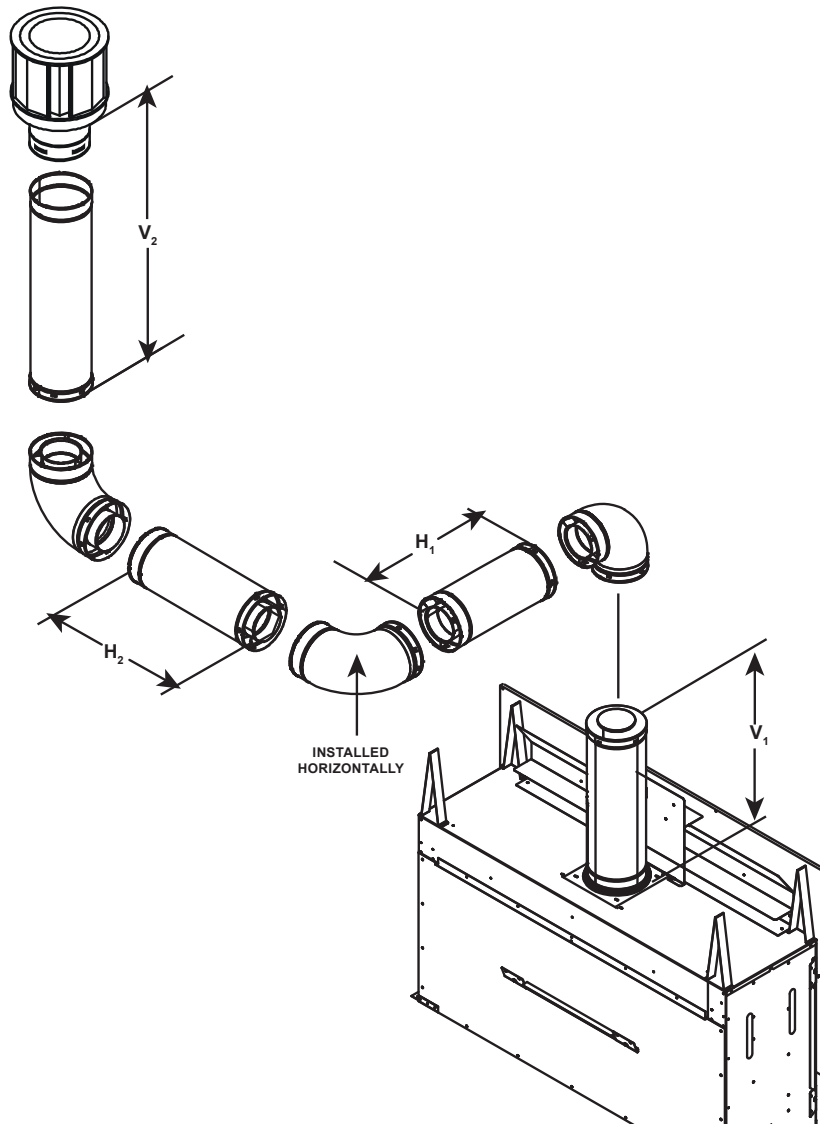


Figure 4.13

# 5 Vent Clearances and Framing

## A. Pipe Clearances to Combustibles

**WARNING! Risk of Fire! Maintain air space clearance to vent. DO NOT pack insulation or other combustibles:**

- Between ceiling firestops
- Between wall shield firestops
- Around vent system

Failure to keep insulation or other material away from vent pipe could cause overheating and fire.

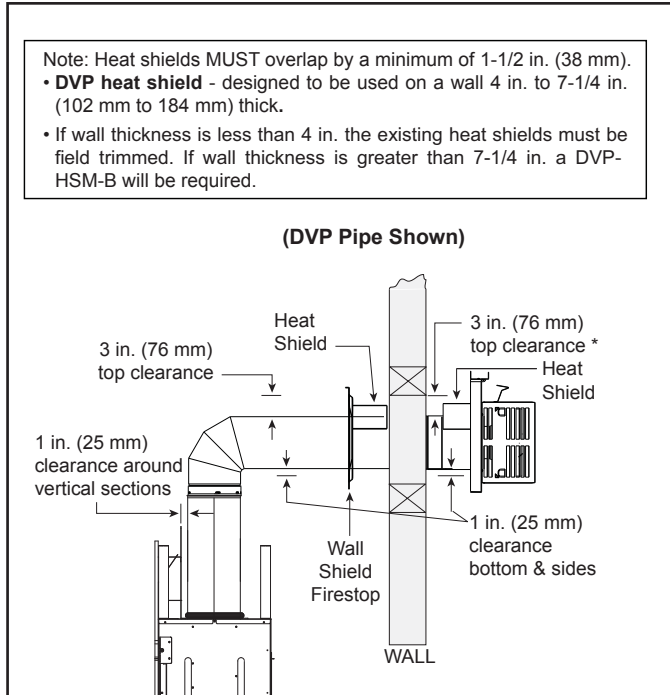


Figure 5.1 Horizontal Venting Clearances To Combustible Materials

## B. Wall Penetration Framing/Firestops

### Combustible Wall Penetration

Whenever a combustible wall is penetrated, you must frame a hole for the wall shield firestop(s). The wall shield firestop maintains minimum clearances and prevents cold air infiltration.

- The opening must be framed on all four sides using the same size framing materials as those used in the wall construction.
- DVP pipe - A wall shield firestop must be placed on each side of an interior wall. A minimum 1-1/2 in. (38 mm) overlap of attached heat shields must be maintained.
- See Section 7.F. for information for regarding the installation of a horizontal termination cap.

### Non-Combustible Wall Penetration

If the hole being penetrated is surrounded by non-combustible materials such as concrete, a hole with diameter one inch greater than the pipe is acceptable.

**Note:** Do not pack the gap with insulation.

Whenever a non-combustible wall is penetrated, the wall shield firestop is only required on one side and no heat shield is necessary.

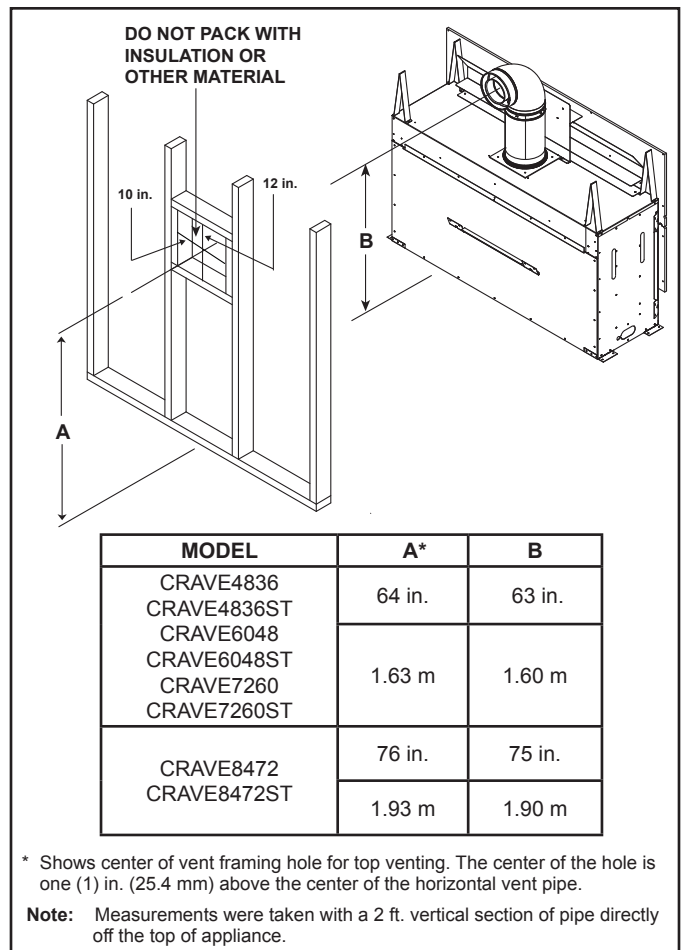


Figure 5.2 Wall Penetration

### C. Install the Ceiling Firestop

A ceiling firestop **MUST** be used between floors and attics.

- **DVP pipe only** - Frame an opening 10 in. by 10 in. (254 mm by 254 mm) whenever the vent penetrates a ceiling/floor. See Figure 5.3.
- Frame the area with the same sized lumber as used in ceiling/floor joist.
- The ceiling firestop may be installed above or below the ceiling joists when installed with an attic insulation shield. It must be under joists between floors that are not insulated. Refer to Figure 5.4.
- Secure with two fasteners on each side.

**WARNING! Risk of Fire! DO NOT pack insulation around the vent. Insulation must be kept back from the pipe to prevent overheating.**

### D. Install Attic Insulation Shield

**WARNING! Fire Risk. DO NOT allow loose materials or insulation to touch vent. Hearth & Home Technologies requires the use of an attic shield.**

The International Fuel Gas Code requires an attic shield constructed of 26 gauge minimum steel that extends at least 2 in. (51 mm) above insulation.

- Attic insulation shields must meet specified clearances to combustible materials and be secured in place.
- An attic insulation shield kit is available from Hearth & Home Technologies. Contact your dealer to order. Install attic insulation shield according to instructions included with kit.

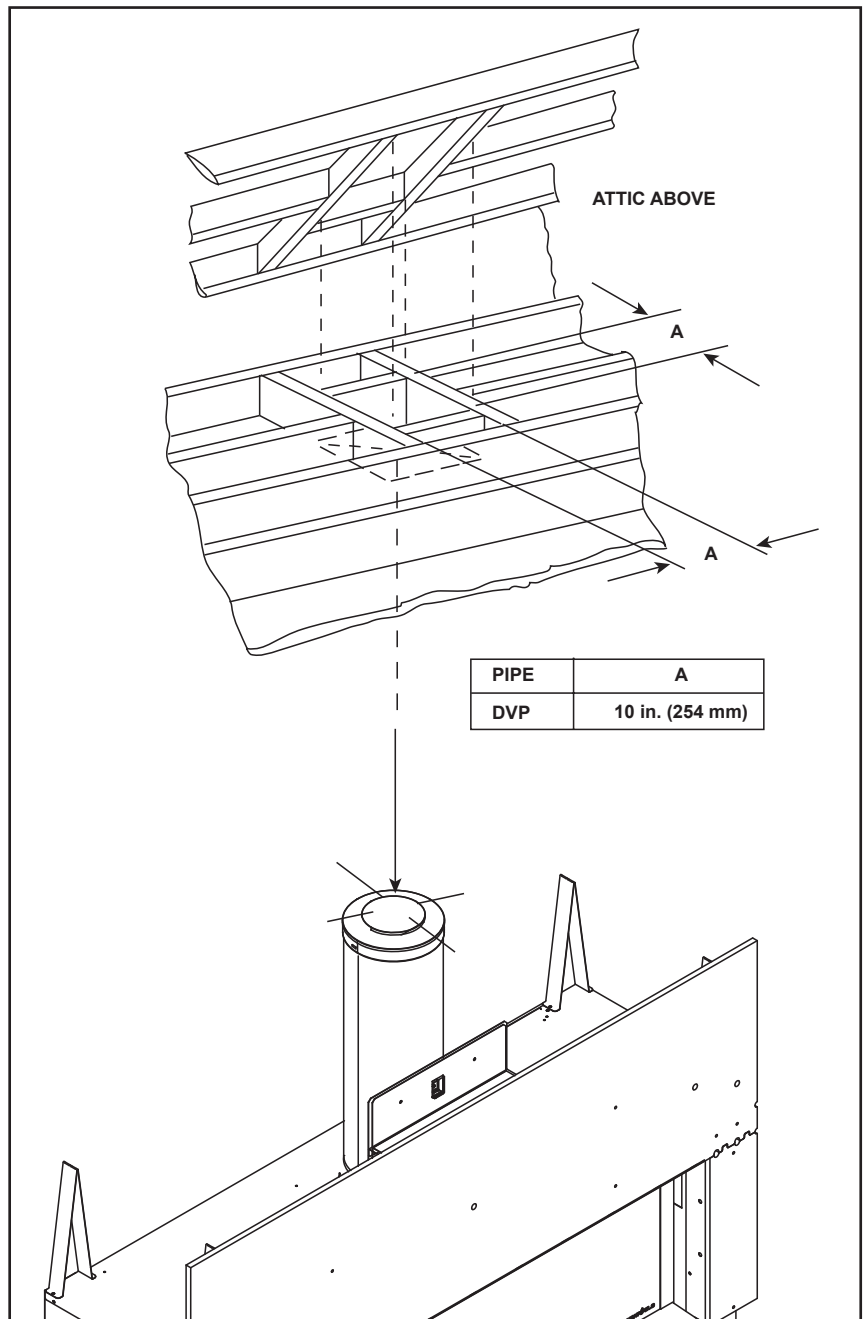


Figure 5.3 Installing Ceiling Firestop

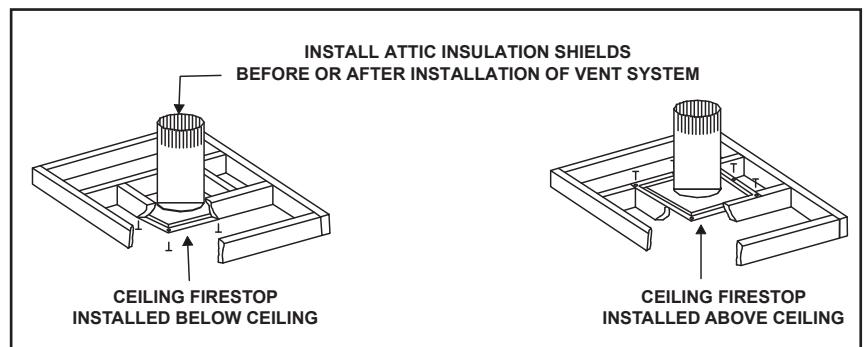


Figure 5.4 Installing the Attic Shield



## E. Installing the Optional Heat-Zone® Gas Kit

- Locate the Heat-Zone® ports on the left and right sides of the appliance. See Figure 5.5. Remove the knockouts from the appliance with a tin snips.
- Place the Heat-Zone® adapter box into position prior to the final positioning of the fireplace as shown in Figure 5.5. Secure using eight self-tapping screws. Ensure the Heat-Zone® knockouts are completely covered by the adapter box.
- Center the duct collar around the exposed hole and attach it to the appliance with 3 screws.

Note: The adapter box will protrude out further than the one inch standoffs on the appliance.

- Determine the location for the air register/fan housing assembly.

Reference the Heat-Zone® Kit instructions for the remaining installation steps.

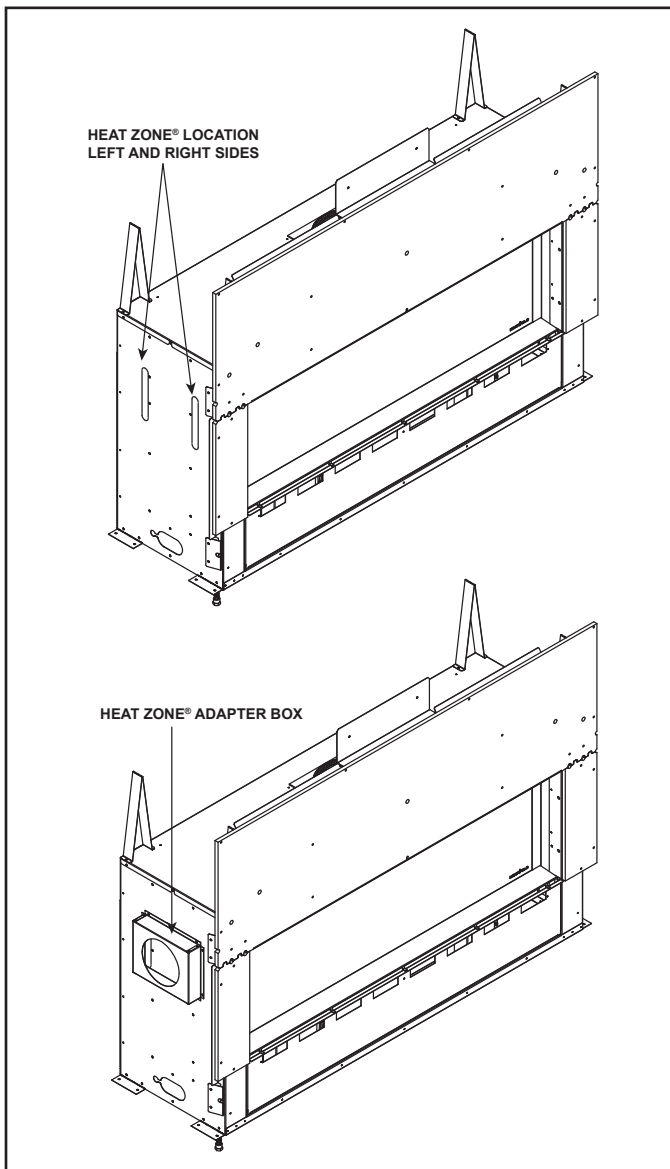


Figure 5.5 Heat Zone Adapter

# 6 Appliance Preparation

## A. Vent Collar Preparation

**CAUTION! Risk of Cuts, Abrasions or Flying Debris.** Wear protective gloves and safety glasses during installation. Sheet metal edges are sharp.

1. Position the pipe heat shield up against the header and attach to header with two screws.

**WARNING! Risk of Fire!** Pipe heat shield must be fastened to header.

2. Place a 24 inch vent section on the starting collar.

**WARNING! Risk of Fire!**

**DO NOT attach elbow directly to the appliance.**

- The CRAVE4836/CRAVE4836ST, CRAVE6048/CRAVE6048ST and CRAVE7260/CRAVE7260ST require a minimum of 24 inches of vertical venting before attaching any elbow to the appliance.
- The CRAVE8472/CRAVE8472ST requires a minimum of 36 inches of vertical venting before attaching any elbow to the appliance.

3. Place the 1/8 inch thick, square fiberglass gasket over the initial 24 inch vent section.
4. Place the fiberglass rope ring over the gasket. Ensure both the gasket and the rope ring are seated on the top of the appliance. See Figure 6.2.

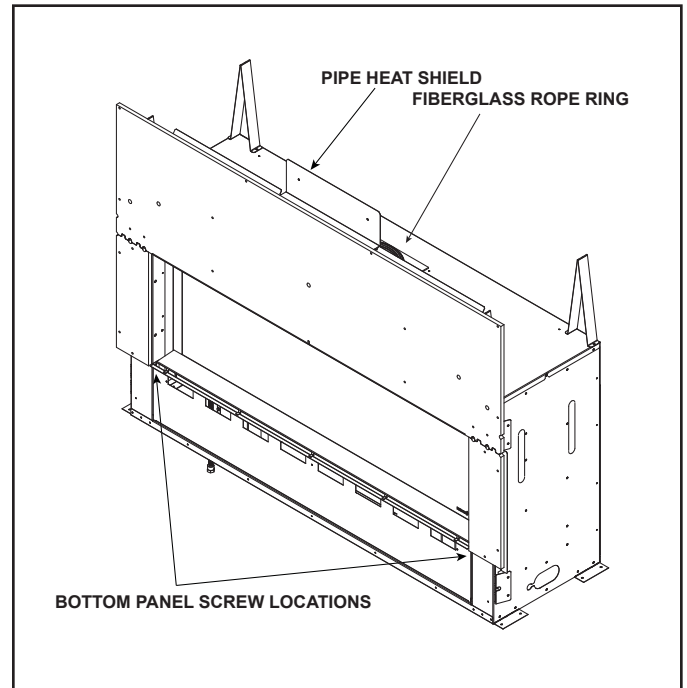


Figure 6.1 Location of Fiberglass Rope Ring

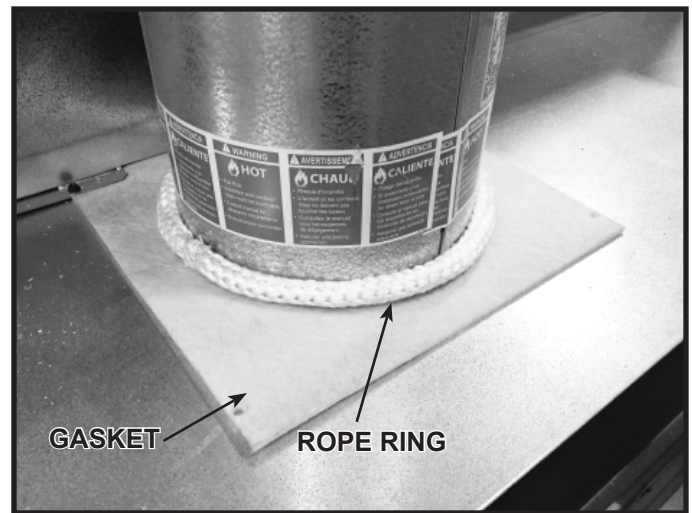


Figure 6.2 Fiberglass Rope Ring Installed

## B. Securing and Leveling the Appliance

**WARNING! Risk of Fire! Prevent contact with:**

- Sagging or loose insulation
- Insulation backing or plastic
- Framing and other combustible materials

Block openings into the chase to prevent entry of blown-in insulation. Make sure insulation and other materials are secured.

**DO NOT** notch the framing around the appliance standoffs. Failure to maintain air space clearance could cause overheating and fire.

To properly position, level, and secure the appliance, see below. Nailing tabs are provided to secure the appliance to the framing members.

- Bend out the two nailing tabs on each side.
- Place the appliance into position.
- Keep nailing tabs flush with the framing. See Figure 6.3.
- Level the appliance from side to side and front to back.
- Shim the appliance as necessary. It is acceptable to use wood shims underneath the appliance.
- Secure the appliance to the framing by using nails or screws through the nailing tabs.

Some figures in manual show the fireplace installed on the floor. However, this fireplace can be elevated off the floor provided that the fireplace is properly supported by framing materials and the ceiling clearances are maintained.

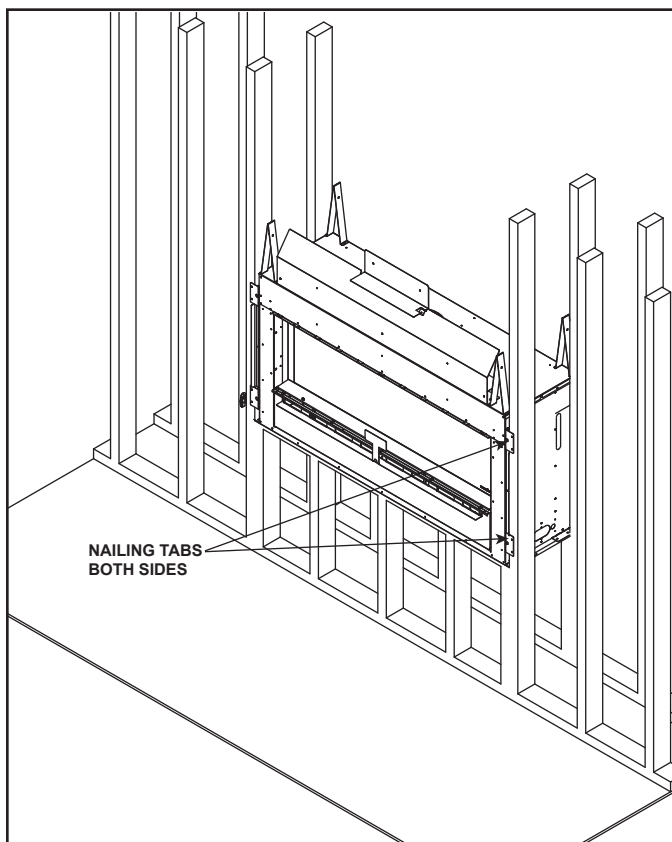


Figure 6.3 Nailing Tab Locations

## Setting the Fireplace into the Framing

The left and right nailing tabs were designed as a means to ensure the fireplace is mounted flush with the framing materials. See Figures 6.3-6.5.

1. The shipping flanges protrude further out from the appliance than the side standoffs. The shipping flange may be bent upward or broken off in order to place the appliance into position in the framing.
2. Bend out all nailing tabs. The see-through model will have eight nailing tabs. The single-sided model will have four nailing tabs.
3. Screw each nailing tab to the adjoining framing material. Ensure that the one inch air space clearance is maintained on the sides and back of the fireplace. See Figures 3.5-3.8 for framing and clearance details.

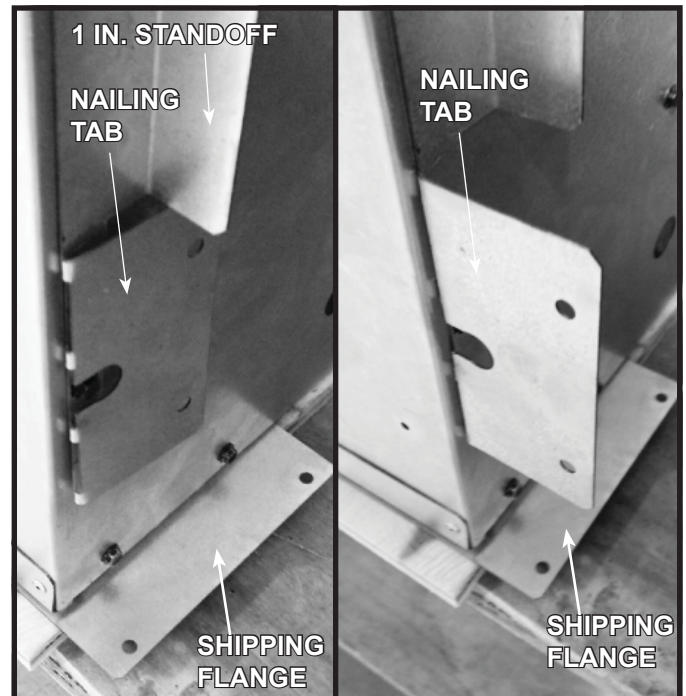


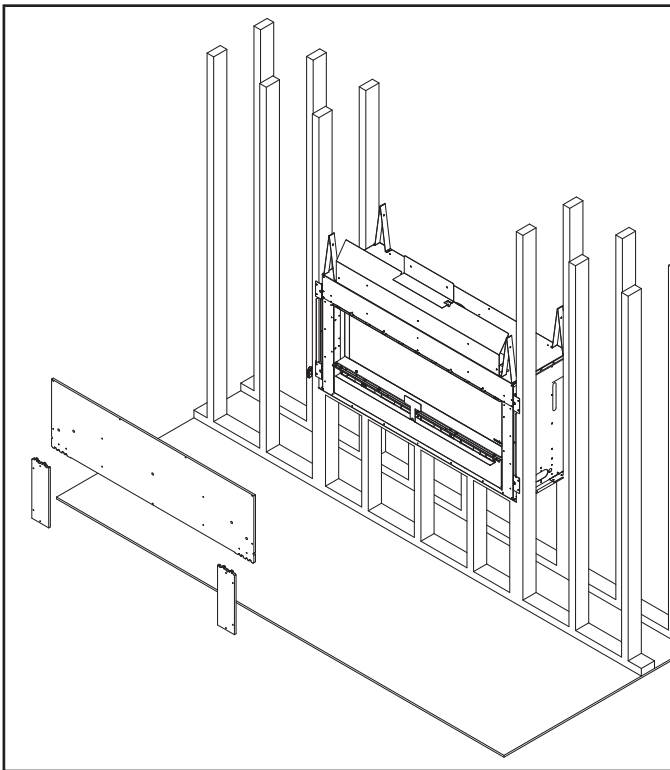
Figure 6.4 Nailing Tabs Shipping Position

Figure 6.5 Nailing Tabs Installation Position

## C. Installing Non-Combustible Facing Material

### **WARNING! Risk of Fire!**

- Follow these instructions exactly.
- Facing materials must be installed properly to prevent fire.
- No materials may be substituted without authorization by Hearth & Home Technologies.
- Remove protective cardboard sleeve from non-combustible facing pieces, which are included with the appliance.
- Install non-combustible facing material to the appliance using the 2 inch screws supplied in the manual bag assembly. There may be extra screws included.
- Attach top board to the framing members with regular sheetrock screws or nails. See Figure 6.6.
- Attach left and right side pieces to framing members with regular sheetrock screws or nails.
- Use a wet or dry towel or soft brush to remove dust or dirt from facing material.
- See Section 10 for finishing materials guidelines.



**Figure 6.6 Install Factory-Included Non-Combustible Facing Material**

# 7 Venting and Chimneys

## A. Assemble Vent Sections

### Attach Vent to the Firebox Assembly

**Note:** The end of the pipe sections with the lanced tabs will face toward the appliance.

Attach the first pipe section to the starting collar:

- Lanced pipe end of the starting collar.
- Inner pipe over inner collar.
- Push the pipe section until all lanced tabs snap in place.
- Lightly tug on pipe to confirm it has locked.

### Required Commercial, Multi-family (Multi-level exceeding two stories), or High-Rise Applications

All outer pipe joints must be sealed with 100% silicone (300° F minimum continuous exposure rating), including the slip section that connects directly to the horizontal termination cap.

- Apply a bead of silicone sealant (300° F minimum continuous exposure rating) inside the female outer pipe joint prior to joining sections. See Figure 7.1.
- Only outer pipes need to be sealed. All unit collar, pipe, slip section, elbow and cap outer flues shall be sealed in this manner, unless otherwise stated.

**WARNING! Risk of Fire or Explosion! DO NOT break silicone seals on slip sections. Use care when removing termination cap from slip pipe. If slip section seals are broken during removal of the termination cap, vent could leak.**

### Assemble Pipe Sections

Per Figure 7.2:

- Start the inner pipe on the lanced end of section A into the flared end of section B.
- Start the outer pipe of section A over the outer pipe of section B.
- Once both vents sections are started, push firmly until all lanced tabs lock into place.
- Lightly tug on the pipe to confirm the tabs have locked.

It is acceptable to use screws no longer than 1/2 in. (13 mm) to hold outer pipe sections together. If predrilling holes, **DO NOT** penetrate inner pipe.

For 90° and 45° elbows that are changing the vent direction from horizontal to vertical, one screw minimum should be put in the outer flue at the horizontal elbow joint to prevent the elbow from rotating. Use screws no longer than 1/2 in. (13 mm). If predrilling screw holes, **DO NOT** penetrate inner pipe.



Figure 7.1 High Temperature Silicone Sealant

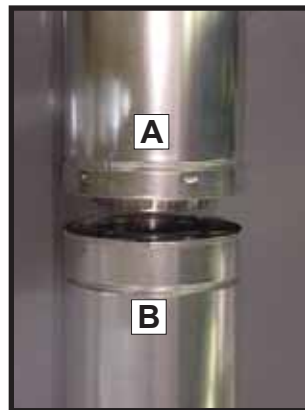


Figure 7.2



Figure 7.3

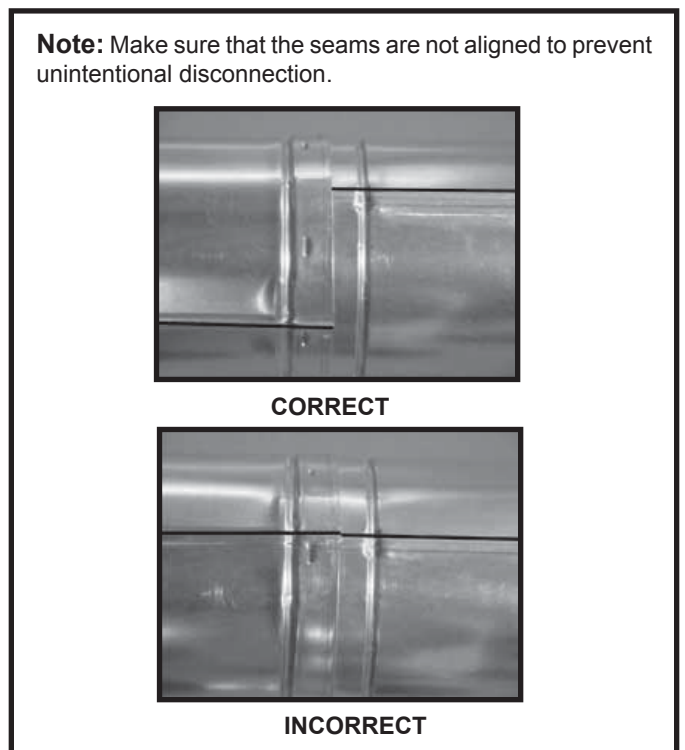


Figure 7.4 Seams

## B. Assemble Slip Sections

- Slide the inner flue of the slip section into the inner flue of the pipe section and the outer flue of the slip section over the outer flue of the pipe section. See Figure 7.5.
- Slide together to the desired length.

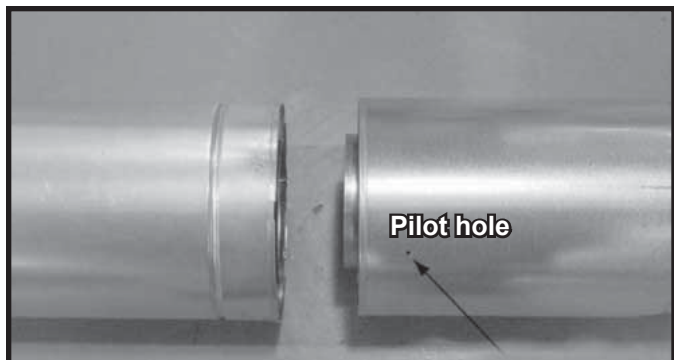


Figure 7.5 Slip Section Pilot Holes

- Maintain a 1-1/2 in. (38 mm) overlap between the slip section and the pipe section.
- Secure the pipe and slip section with two screws no longer than 1/2 in. (13 mm), using the pilot holes in the slip section. See Figure 7.6.

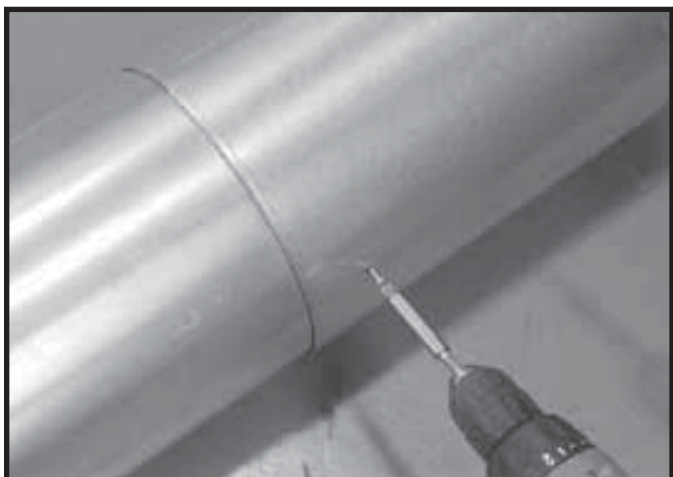


Figure 7.6 Screws into Slip Section

- Continue adding pipe as necessary following instructions in “Assembling Pipe Sections.”

**NOTICE:** If slip section is too long, the inner and outer flues of the slip section can be cut to the desired length.

**NOTICE:** When installing a vent system with an HRC termination cap, all pipe system joints shall be sealed using a silicone sealant with a minimum of 300°F continuous exposure rating.

- Apply a bead of silicone sealant inside the female outer pipe joint prior to joining sections.
- Only outer pipes are sealed, sealing the inner flue is not required.
- All unit collar, pipe, slip section, elbow and cap outer flues shall be sealed.

## C. Secure The Vent Sections

- Vertical runs originating off the top of the appliance, with no offsets, must be supported every 8 ft. (2.44 m) after the maximum allowed 25 ft. (7.62 m) of unsupported rise.
- Vertical runs, after any elbow, must be supported every 5 ft. (1.52 m).
- Horizontal runs must be supported every 5 feet (1.52 m).
- Vent supports or plumbers strap (spaced 120° apart) may be used to support. See figures 7.7 and 7.8.
- Wall shield firestops may be used to provide horizontal support.
- Ceiling firestops have tabs that may be used to provide vertical support.

**WARNING! Risk of Fire, Explosion or Asphyxiation!** Improper support could allow vent to sag and separate. Use vent run supports and connect vent sections per installation instructions. **DO NOT** allow vent to sag below connection point to appliance.

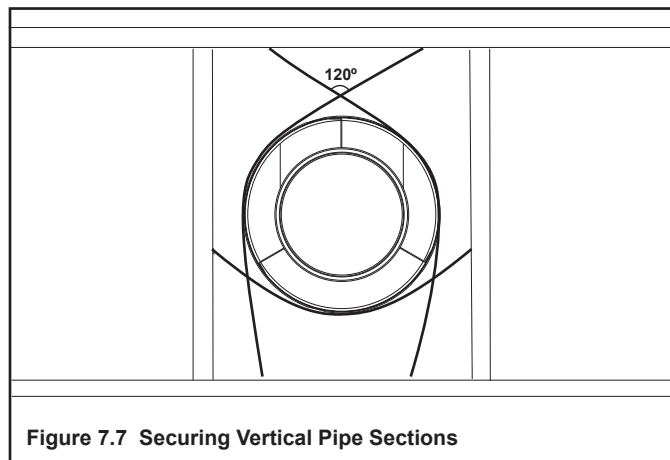


Figure 7.7 Securing Vertical Pipe Sections

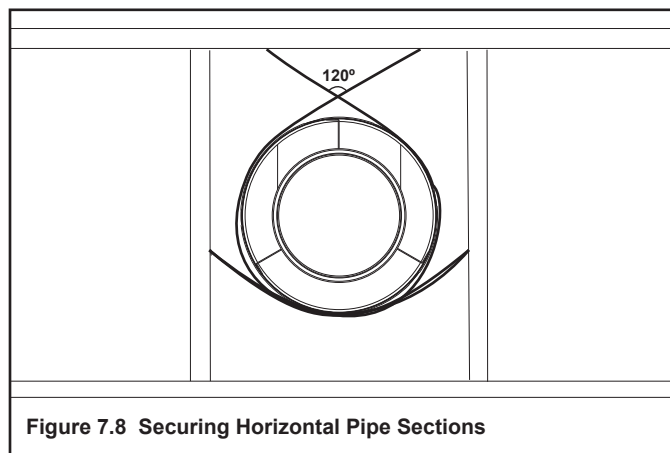


Figure 7.8 Securing Horizontal Pipe Sections

## D. Disassemble Vent Sections

- Rotate either section (see Figure 7.9) so the seams on both pipe sections are aligned as shown in Figure 7.10
- Pull carefully to separate the pieces of pipe.

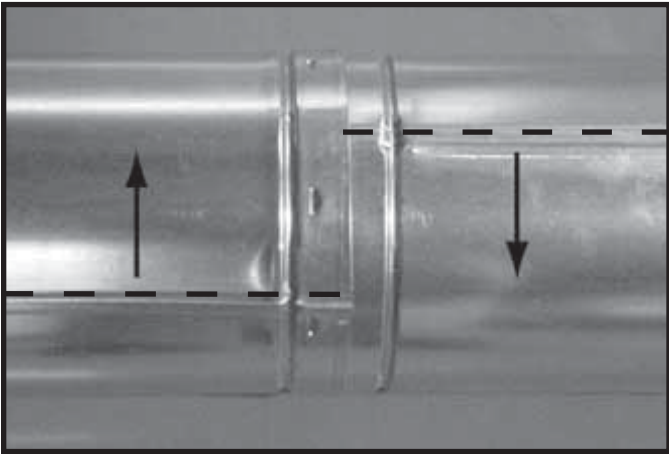


Figure 7.9 Rotate Seams for Disassembly

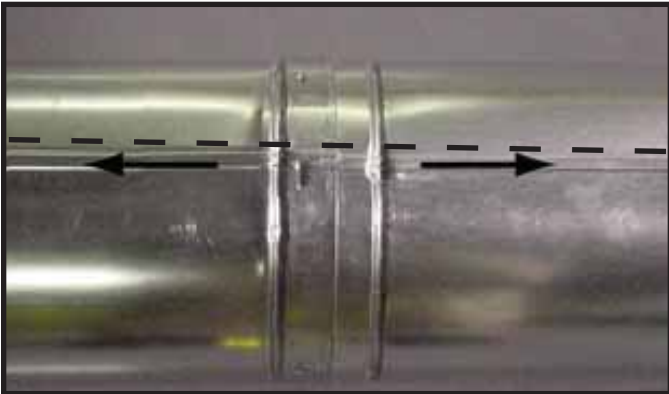
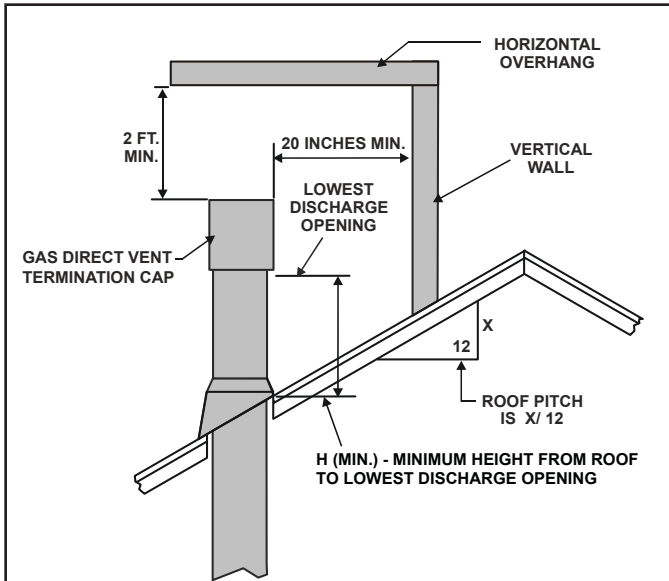


Figure 7.10 Align and Disassemble Vent Sections

## E. Vertical Termination Requirements

### Install Metal Roof Flashing

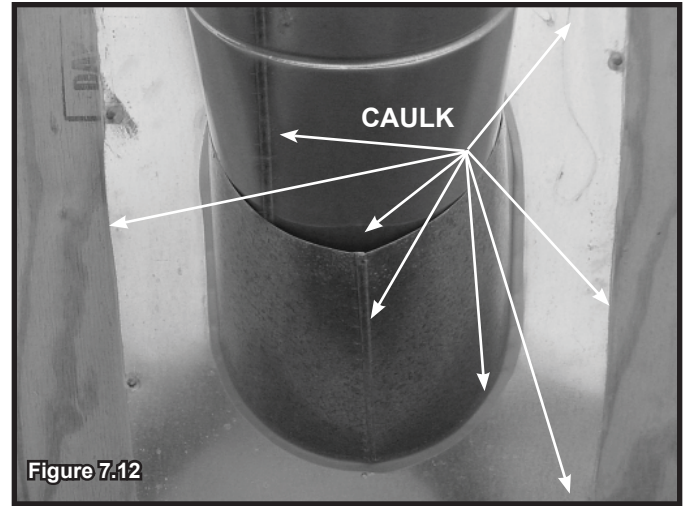
- See minimum vent heights for various pitched roofs (Figure 7.11) to determine the length of pipe to extend through the roof.
- Slide the roof flashing over the pipe sections extending through the roof as shown in Figure 7.12.



Roof Pitch	H (Min.) Ft.
Flat to 6/12.....	1.0*
Over 6/12 to 7/12.....	1.25*
Over 7/12 to 8/12.....	1.5*
Over 8/12 to 9/12.....	2.0*
Over 9/12 to 10/12.....	2.5*
Over 10/12 to 11/12.....	3.25
Over 11/12 to 12/12.....	4.0
Over 12/12 to 14/12.....	5.0
Over 14/12 to 16/12.....	6.0
Over 16/12 to 18/12.....	7.0
Over 18/12 to 20/12.....	7.5
Over 20/12 to 21/12.....	8.0

\* 3 foot minimum in snow regions

Figure 7.11 Minimum Height From Roof To Lowest Discharge Opening



### Assemble and Install Storm Collar

**CAUTION! Risk of Cuts, Abrasions or Flying Debris.** Wear protective gloves and safety glasses during installation. Sheet metal edges are sharp.

- Slide the storm collar onto the exposed pipe section and align brackets.
- Insert a bolt (provided) through the brackets and install nut. Do not completely tighten. See Figure 7.13.



- Slide the assembled storm collar down the pipe section until it rests on the roof flashing (see Figure 7.14).
- Tighten nut and make sure the collar is tight against the pipe section.
- Caulk around the top of the storm collar. See Figure 7.14.

**NOTICE:** Failure to properly caulk the roof flashing and pipe seams could permit entry of water.

- Caulk the gap between the roof flashing and the outside diameter of the pipe.
- Caulk the perimeter of the flashing where it contacts the roof surface. See Figure 7.12.
- Caulk the overlap seam of any exposed pipe sections that are located above the roof line.



## Install Vertical Termination Cap

- Attach the vertical termination cap by sliding the inner collar of the cap into the inner flue of the pipe section while placing the outer collar of the cap over the outer flue of the pipe section.
- Secure the cap by driving three self-tapping screws (supplied) through the pilot holes in the outer collar of the cap into the outer flue of the pipe. See Figure 7.14.



Figure 7.14

## F. Horizontal Termination Requirements

### Heat Shield Requirements for Horizontal Termination

**WARNING! Risk of Fire!** To prevent overheating and fire, heat shields must extend through the entire wall thickness.

- **DO NOT** remove the heat shields attached to the wall shield firestop and the horizontal termination cap (shown in Figure 7.15).
- Heat shields must overlap 1-1/2 in. (38 mm) minimum.

There are two sections of the heat shield. One section is factory-attached to the wall shield firestop. The other section is factory-attached to the cap. See Figure 7.15.

If the wall thickness does not allow the required 1-1/2 in. (38 mm) heat shield overlap when installed, an extended heat shield must be used.

- If the wall thickness is less than 4 in./102 mm, the heat shields on the cap and wall shield firestop must be trimmed. A minimum 1-1/2 in. (38 mm) overlap **MUST** be maintained.
- Use an extended heat shield if the finished wall thickness is greater than 7-1/4 in. (184 mm).
- The extended heat shield may need to be cut to length maintaining sufficient length for a 1-1/2 in. (38 mm) overlap between heat shields.
- Attach the extended heat shield to either of the existing heat shields using the screws supplied with the extended heat shield. Refer to vent components diagrams in the back of this manual.
- Rest the small leg on the extended heat shield on top of the pipe section to properly space it from the pipe section.

**Important Notice:** Heat shields may not be field constructed.

## Install Horizontal Termination Cap

**WARNING! Risk of Fire!** The telescoping flue section of the termination cap **MUST** be used when connecting vent.

- 1-1/2 (38 mm) minimum overlap of flue telescoping section is required.

Failure to maintain overlap could cause overheating and fire.

- Vent termination must not be recessed in the wall. Siding may be brought to the edge of the cap base.
- Flash and seal as appropriate for siding material at outside edges of cap.
- When installing a horizontal termination cap, follow the cap location guidelines as prescribed by current **ANSI Z223.1** and **CAN/CGA-B149** installation codes and refer to Section 6 of this manual.

**CAUTION! Risk of Burns!** Local codes may require installation of a cap shield to prevent anything or anyone from touching the hot cap.

**NOTICE:** For certain exposures which require superior resistance to wind-driven rain penetration, a flashing kit and HRC caps are available. When penetrating a brick wall, a brick extension kit is available for framing the brick.

**Note:** When using termination caps with factory-supplied heat shield attached, no additional wall shield firestop is required on the exterior side of a combustible wall.

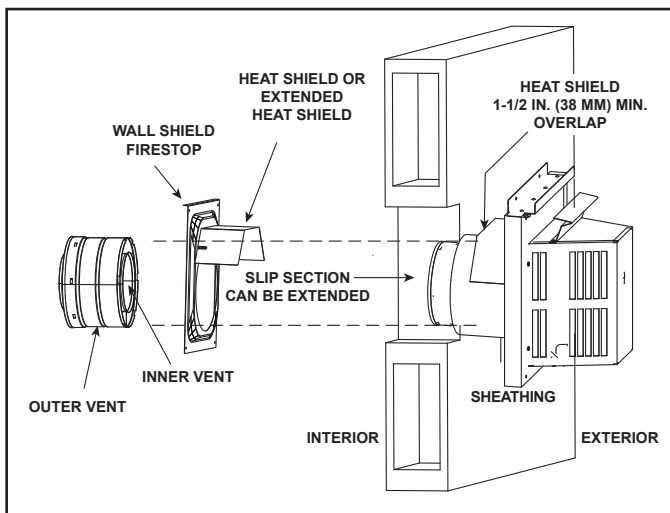


Figure 7.15 Venting Through the Wall

# 8 Electrical Information

## A. General Information

**WARNING! Risk of Shock or Explosion! DO NOT** wire 110-120 VAC to the valve or to the appliance wall switch. Incorrect wiring will damage controls.

**NOTICE:** This appliance must be electrically wired and grounded in accordance with local codes or, in the absence of local codes, with **National Electric Code ANSI/NFPA 70-latest edition** or the **Canadian Electric Code CSA C22.1**.

- Wire the appliance junction box to unswitched 110-120 VAC. This is required for proper operation of the appliance.
- A 110-120 VAC circuit for this product must be protected with ground-fault circuit-interrupter protection, in compliance with the applicable electrical codes, when it is installed in locations such as in bathrooms or near sinks.
- Low voltage and 110/120 VAC voltage cannot be shared within the same wall box.

## Electrical Service and Repair

**WARNING! Risk of Shock!** Label all wires prior to disconnection when servicing controls. Wiring errors can cause improper and dangerous operation. Verify proper operation after servicing.

**WARNING! Risk of Shock!** Replace damaged wire with type 105° C rated wire. Wire must have high temperature insulation.

## Accessories Requirements

- This appliance may be used with a wall switch, wall mounted thermostat and/or a remote control.

Wiring for optional Hearth & Home Technologies approved accessories should be done now to avoid reconstruction. Follow instructions that come with those accessories.

## Junction Box Installation

**WARNING! Risk of Shock!** Label all wires prior to disconnection when servicing controls. Wiring errors can cause improper and dangerous operation. Verify proper operation after servicing.

**WARNING! Risk of Shock!** Replace damaged wire with type 105° C rated wire. Wire must have high temperature insulation.

1. Remove bottom metal panel by removing two screws. Screw locations are shown in Figure 8.1. After removing two screws, gently lift the panel off the appliance avoiding contact with the non-combustible board if possible.
2. Remove the one screw that secures the junction box to the control tray panel. See Figure 8.2.
3. Remove screws on left and right sides of component heat shield and lift it out of the control cavity.

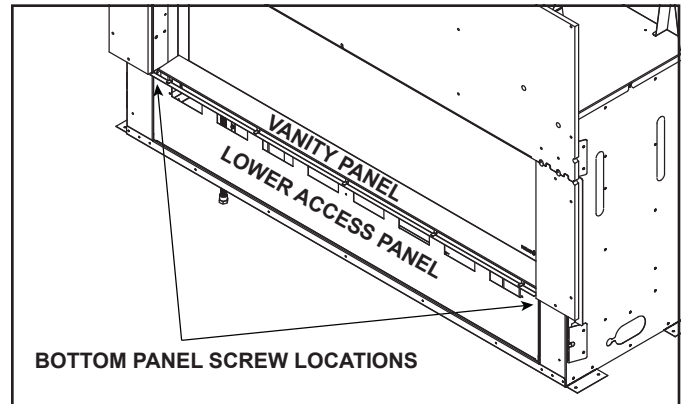


Figure 8.1 Lower Access Panel Location

4. Route the wire through the strain relief in the outer wrap and up through the cutout/slot located on the metal tray under the junction box.
5. Make the connection inside the junction box to the 110-120V wire. Connect green to the ground nut, black to black, and white to white.
6. To reattach the junction box, insert one end of the junction box in the slot provided and securely screw the other end of the junction box to the control tray panel.
7. Reinstall component heat shield.

**CAUTION! Risk of Overheating!** Component heat shield **MUST** be installed before operating appliance. Electrical components will be damaged.



Figure 8.2 Junction Box Detail

In the event that the junction box may need to be accessed or installed after finish methods have been applied, access is possible by removing the vanity panel.

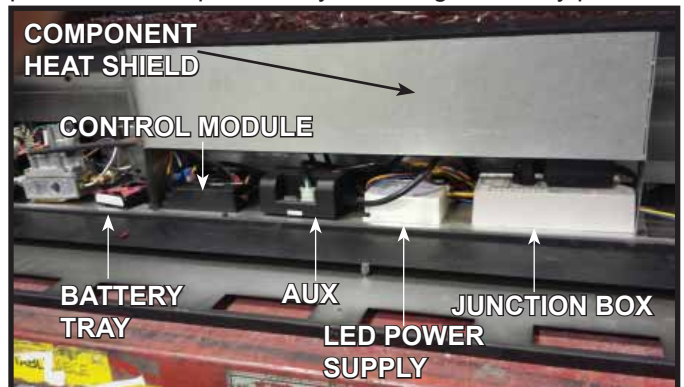


Figure 8.3. Valve Cavity (Lower Access Panel Removed)

## B. Wiring Requirements

### IntelliFire™ Plus Ignition System Wiring

- Wire the appliance junction box to 110-120 VAC for proper operation of the appliance.

**WARNING! Risk of Shock or Explosion! DO NOT wire IPI controlled appliance junction box to a switched circuit. Incorrect wiring will override IPI safety lockout.**

- Refer to Figure 8.4, IPI Wiring Diagram.
- This appliance is equipped with an IntelliFire™ Plus control valve which operates on a 6 volt/1.5 AMP system.
- Plug the 6 volt transformer plug into the appliance junction box to supply power to the unit OR install 4 AA cell batteries (not included) into the battery pack before use.

**NOTICE: Batteries should only be used as a power source in the event of an emergency power outage. Batteries should not be used as a primary long-term power source. Battery polarity must be correct when installing batteries. When using batteries as a power source, the 6-volt transformer must be unplugged from the receptacle.**

Do not store batteries in the battery pack when the appliance is powered by the 6 volt transformer connected to permanent electrical service.

## Accessories Requirements

- This appliance ships standard with a remote control.

Wiring for optional Hearth & Home Technologies approved accessories should be done now to avoid reconstruction. Follow instructions that come with those accessories.

The junction box, control module, LED power supply and wall switch receiver can be accessed by removing the vanity panel and component heat shield. The decorative front must be removed to access these components. See Figure 8.2.

**CAUTION! Risk of Overheating! Component heat shield MUST be installed before operating appliance. Electrical components will be damaged.**

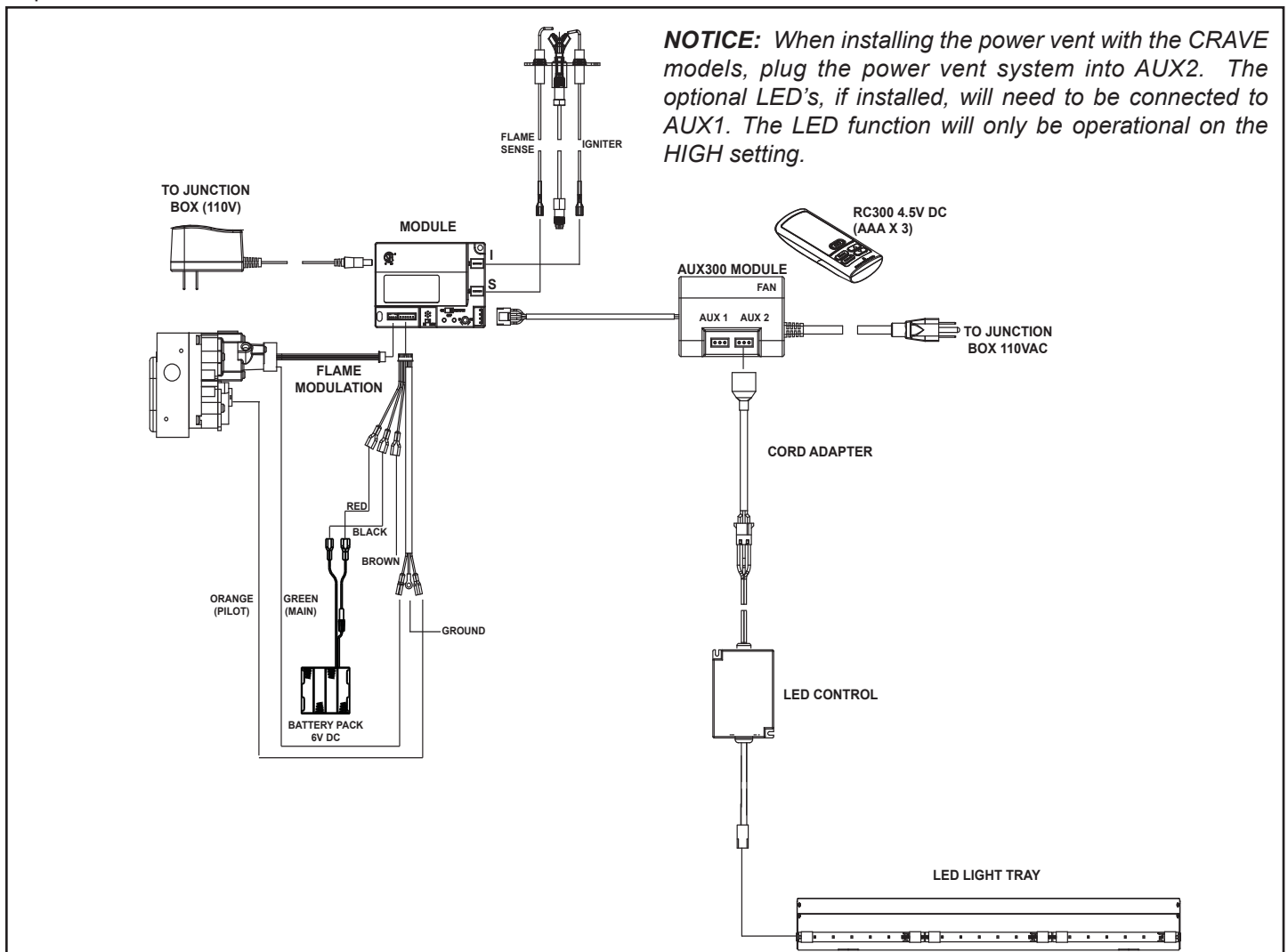


Figure 8.4 IntelliFire™ Plus Wiring Diagram with Remote

# 9 Gas Information

## A. Fuel Conversion

- Make sure the appliance is compatible with available gas types.
- Conversions must be made by a qualified service technician using Hearth & Home Technologies specified and approved parts.

## B. Gas Pressure

- Optimum appliance performance requires proper input pressures.
- Gas line sizing requirements will be determined in ANSI Z223.1 National Fuel Gas Code in the USA and CAN/CGA B149 in Canada.
- Pressure requirements are:

Gas Pressure	Natural Gas	Propane
Minimum inlet pressure	5.0 in. w.c.	11.0 in. w.c.
Maximum inlet pressure	10.0 in. w.c.	13.0 in. w.c.
Manifold pressure	3.5 in. w.c.	10.0 in. w.c.

**WARNING! Risk of Fire or Explosion! High pressure will damage valve. Low pressure could cause explosion.**

- Verify inlet pressures. Verify minimum pressures when other household gas appliances are operating.
- Install regulator upstream of valve if line pressure is greater than 1/2 psig.
- Valve pressure taps are accessible by removing the decorative front and the vanity panel.

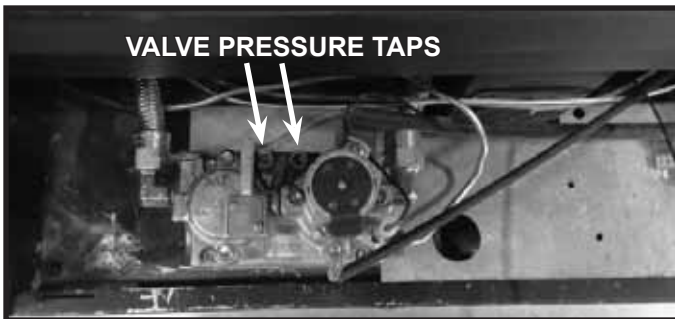


Figure 9.1. Valve Pressure Taps.

**⚠ WARNING**

Fire Risk.  
Explosion Hazard.  
High pressure will damage valve.

- Disconnect gas supply piping BEFORE pressure testing gas line at test pressures above 1/2 psig.
- Close the manual shutoff valve BEFORE pressure testing gas line at test pressures equal to or less than 1/2 psig.

**Note:** Have the gas supply line installed in accordance with local codes, if any. If not, follow ANSI 223.1. Installation should be done by a qualified installer approved and/or licensed as required by the locality. (In the Commonwealth of Massachusetts installation must be performed by a licensed plumber or gas fitter).

**Note:** A listed (and Commonwealth of Massachusetts approved) 1/2 in. (13 mm) T-handle manual shut-off valve and flexible gas connector are connected to the 1/2 in. (13 mm) control valve inlet.

- **If substituting for these components, please consult local codes for compliance.**

## C. Gas Service Access

**Note:** This appliance does include a manual gas shutoff valve that is located in the valve compartment. This manual gas shutoff valve is accessible for service by removing the decorative front and the vanity panel. The valve is most accessible if it is located forward in the control cavity of the appliance.

Depending upon local code, an additional manual gas shutoff, in a readily accessible area may be required and located upstream from the appliance.

The lower access cover panel is removable if finishing material is not installed. See Figure 9.2.

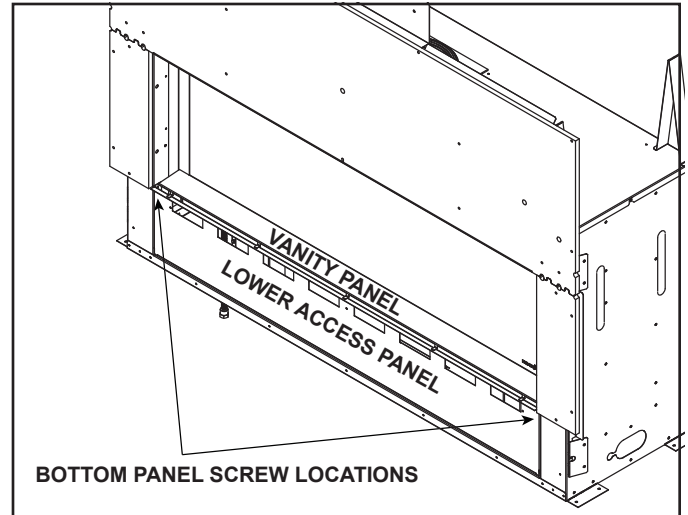


Figure 9.2. Vanity Panel and Lower Access Panel Location

If the finishing materials have been installed around the appliance opening, proceed as follows:

1. Remove vanity panel.
2. Remove screws on left and right sides of component heat shield and lift it out of the control cavity.

**CAUTION! Risk of Overheating! Component heat shield MUST be installed before operating appliance. Electrical components will be damaged.**

3. Unplug the 6V transformer from the junction box. This will turn the power off to the appliance.

- Turn the gas shutoff handle to the “OFF” position to shut off the gas supply.

If additional access is needed, proceed as follows:

- Remove glass assembly from appliance by unlatching the top spring latches from the glass frame and lifting glass frame assembly out of the bottom bracket.
- Remove interior media and refractory from the unit if already installed.
- Remove the media tray. It is attached to the interior firebox bottom with ten screws. See Figure 9.3.
- Remove the two screws that attach the pilot to the burner.
- Remove the four screws securing the burner to the firebox sides and disengage burner from orifice. Remove burner. See Figure 9.3.
- Remove the eight screws that secure the glass window. Remove the glass window. Handle with care. See Figure 9.4.
- Remove light tray from appliance by lifting up and out through the bottom glass opening.



Figure 9.4. Gas and Electrical Access - Remove Glass Window

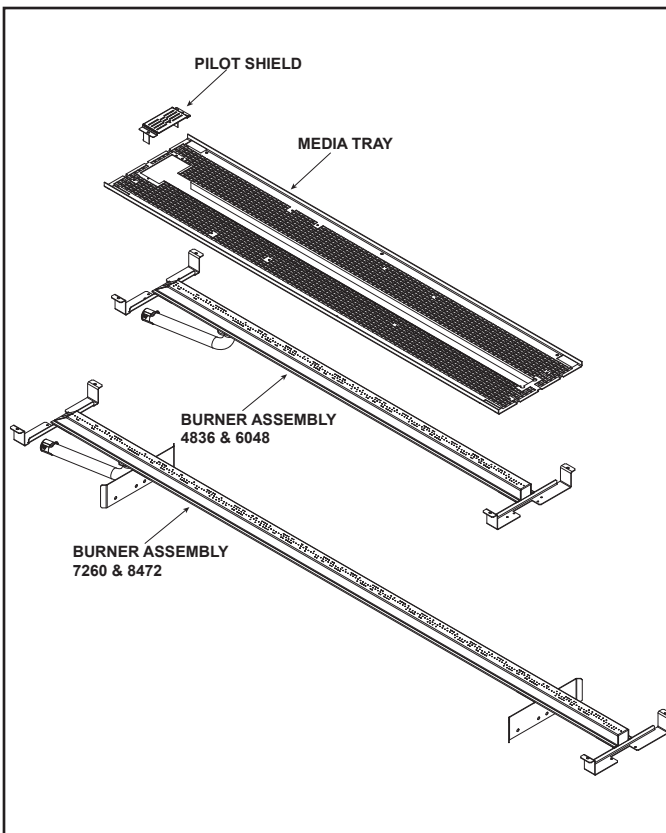


Figure 9.3. Media Tray with Burner and Pilot Shield

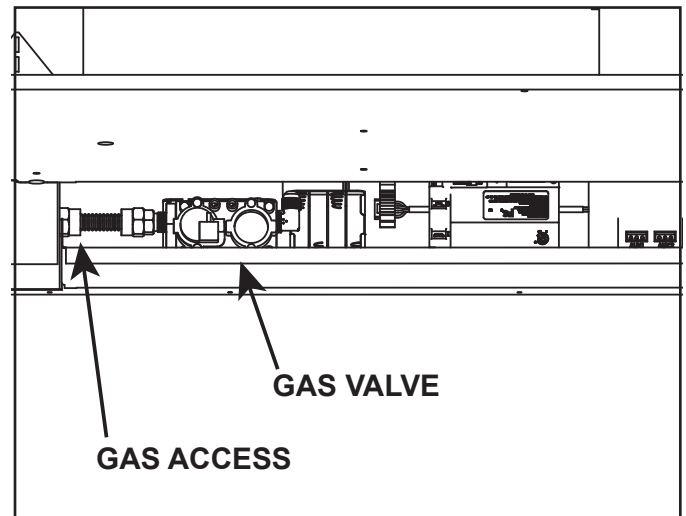


Figure 9.5. Gas Fitting Access with Vanity Panel Removed

## D. Gas Connection

- Refer to Reference Section 3.A for location of gas line access in appliance.
- Gas line may be run through the left side of appliance.
- The gap between supply piping and gas access hole may be caulked with caulk with a minimum of 300°F continuous exposure rating or stuffed with non-combustible, unfaced insulation to prevent cold air infiltration.
- Ensure that gas line does not come in contact with outer wrap of the appliance. Follow local codes.
- Pipe incoming gas line into valve compartment.
- Connect incoming gas line to the 1/2 in. (13 mm) connection on manual shutoff valve.

**WARNING! Risk of Fire or Explosion!** Support control when attaching pipe to prevent bending gas line.

- A small amount of air will be in the gas supply lines.

**WARNING! Risk of Fire or Explosion!** Gas build-up during line purge could ignite.

- Purge should be performed by qualified service technician.
- Ensure adequate ventilation.
- Ensure there are no ignition sources such as sparks or open flames.

Light the appliance. It will take a short time for air to purge from lines. When purging is complete the appliance will light and operate normally.

**WARNING! Risk of Fire, Explosion or Asphyxiation!** Check all fittings and connections with a non-corrosive commercially available leak-check solution. **DO NOT** use open flame. Fittings and connections could have loosened during shipping and handling.

**WARNING! Risk of Fire! DO NOT** change valve settings. This valve has been preset at the factory.

## E. High Altitude Installations

**NOTICE:** If the heating value of the gas has been reduced, these rules do not apply. Check with your local gas utility or authorities having jurisdiction.

When installing above 2000 feet elevation:

- In the USA: Reduce burner orifice 4% for each 1000 feet above 2000 feet.
- In CANADA: Reduce burner orifice 10% for elevations between 2000 feet and 4500 feet. Above 4500 feet, consult local gas utility.

## F. Air Shutter Setting

Air shutter settings may be adjusted by a qualified installer at the time of installation. The air shutter is set at the factory for minimum vertical vent run. Adjust air shutter for longer vertical runs. See Figure 9.6.

- Refer to Gas Service Access instructions in Section 9.C to access the air shutter.
- Loosen the 1/4 in. screw.

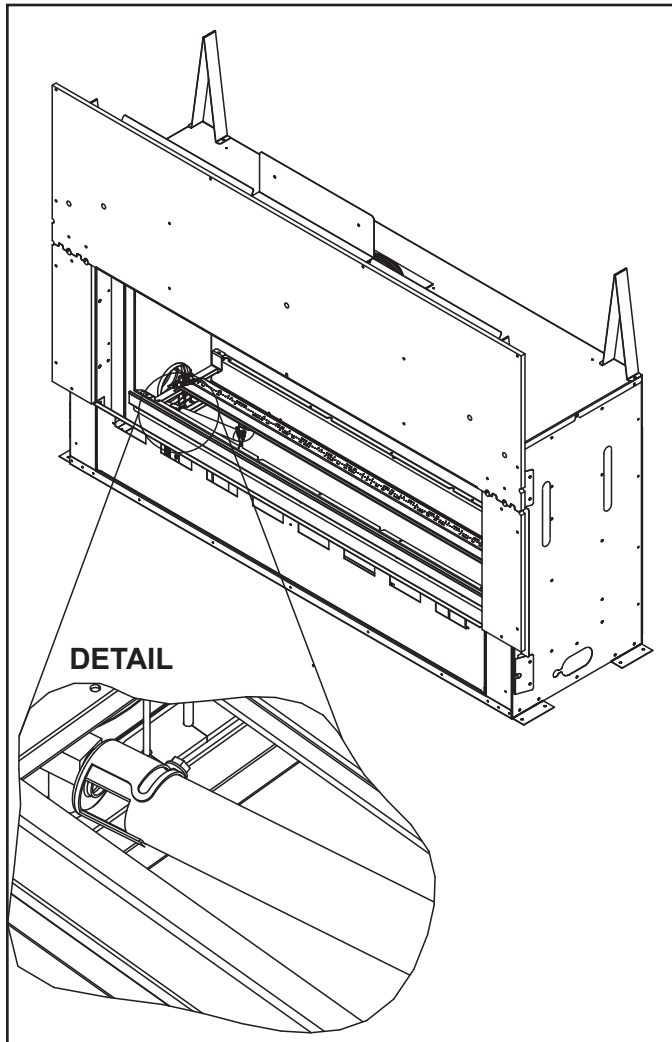


Figure 9.6 Air Shutter Location

- Twist shutter to adjust.
- Shutter may be open for longer horizontal vent runs.
- Do not close the air shutter more than 1/16 in. for NG or 1/4 in. for propane.
- Tighten the screw.

**NOTICE:** If sooting occurs, provide more air by opening the air shutter.

### Air Shutter Settings

CRAVE4836 CRAVE4836ST CRAVE6048 CRAVE6048ST	NG	Propane
GLASS REFRACTORY KIT	Standard Opening= 3/16 in.	Standard Opening= Full Open
LOG KIT	1/4 in.	Full Open

CRAVE7260 CRAVE7260ST	NG	Propane
GLASS REFRACTORY KIT	Standard Opening= 3/8 in.	Standard Opening= Full Open
LOG KIT	3/8 in.	Full Open

CRAVE8472 CRAVE8472ST	NG	Propane
GLASS REFRACTORY KIT	Standard Opening= 1/2 in.	Standard Opening= Full Open
LOG KIT	1/2 in.	Full Open



# 10 Finishing

## A. Facing and Finishing Instructions

**WARNING! Risk of Fire!** Comply with all minimum clearances to combustibles as specified. Framing closer than the minimums listed must be constructed entirely of noncombustible materials (i.e., steel studs, concrete board, etc.).

### Splatter Guard

The splatter guard is a piece of corrugated material used to protect the appliance during the installation process before finishing work on the whole hearth is complete. A splatter guard is factory-installed on CRAVE models. Splatter guards must be removed before appliance is fired.

**WARNING! Risk of Fire!** Remove the splatter guard before lighting the appliance. Shut off gas to the appliance when the splatter guard is in place to prevent accidental operation.

### Finishing Instructions

It is important to follow the framing and finishing instructions to ensure proper placement of fireplace into the surrounding framing/finishing materials.

Wall sheathing materials 1/2 in. thick are specified in this installation manual to properly align with the installed non-combustible material.

**WARNING! Risk of Fire!** DO NOT remove the installed non-combustible board or cover it with combustible material, such as:

- Drywall (gypsum board)
- Plywood
- Materials that do not meet the ASTM E 136 Non-combustibility standard (below).

Removal of installed, non-combustible board and/or use of materials not meeting the ASTM E 136 standard could cause fire.

### Non-Combustible Materials Specification

Material which will not ignite and burn. Such materials are those consisting entirely of steel, iron, brick, tile, concrete, slate, glass or plasters, or any combination thereof.

Materials that are reported as passing **ASTM E 136, Standard Test Method for Behavior of Materials in a Vertical Tube Furnace at 750 °C.**

**WARNING! Risk of Fire!** Maintain specified air space clearances to combustibles. Inadequate air space could cause overheating and fire.

## Finishing Materials

**NOTICE:** The maximum finishing material not only includes the decorative finish materials (marble, tile, slate, etc) but also the thin set, lath and adhesive used to attach the decorative finish material.

**WARNING! Risk of Fire!** DO NOT use screws longer than two inches when attaching finishing materials to installed non-combustible material. Screws longer than two inches will compromise clearance and could cause overheating and fire.

**WARNING! Risk of Fire, Explosion or Asphyxiation!** DO NOT use screws more than one inch long on lower cover panel. Longer screws may penetrate gas line or damage valve or electrical components.

This section discusses installation details associated with the Inside and Overlap Fit methods and specifies additional non-combustible materials required.

When finishing the wall around the fireplace, it is critical that wall sheathing be fastened properly. Wall sheathing fasteners, such as screws or nails, are not permitted in some locations. See Figure 10.1.

It is acceptable to pre-drill holes and use self-tapped screws in the installed non-combustible board which may be used to lathe (a backer for tile, marble, etc.). Screws being installed through the installed non-combustible board should be self-tapping type with a maximum length of 2 inches. See Figure 10.1.

When installing finish material on the lower cover panel, DO NOT drill or install screws longer than one inch. Screws longer than one inch could penetrate the lower cover panel causing damage to components or penetrate the gas line. One inch screws are included in the manual bag assembly that are intended for use when attaching finishing material to lower cover panel. See Figure 10.1.

In regards to the sheetrock mud, a smooth, even surface, covering a wide area of the wall is desired for best results. For best results, follow the tips below.

To Reduce the Risk of Sheetrock Cracking: DO
Use all purpose joint compound.
Use eggshell paint (gloss or semi-gloss).

To Avoid Sheetrock Cracking: DO NOT
Use a quick set or light weight joint compound.
Use flat paint.

**WARNING! Risk of Fire, Explosion or Asphyxiation!** **DO NOT** use screws more than one inch long on lower cover panel. Longer screws may penetrate gas line or damage valve or electrical components.

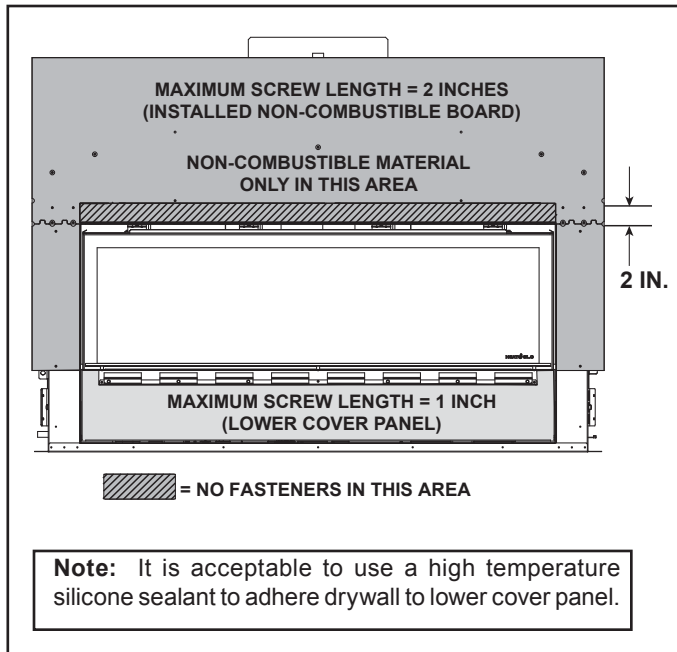


Figure 10.1 Screw Length Requirements

The appliance is designed to mate with 1/2 in. wall sheathing materials such as drywall, plywood, wood composites, or non-combustible materials.

### Finish and Sealing Joints

All joints between the finished wall sheathing and the appliance must be sealed with non-combustible materials. Sealants, such as caulk or mastic used to seal the gap between the wall and the fireplace, should be rated at a minimum continuous exposure to 300°F.

### Finishing Around Opening with Gypsum Wallboard

Gypsum wallboard (drywall) joints adjacent to the fireplace opening, including the non-combustible board on the appliance, require special attention to minimize cracking. When installing gypsum wallboard around the fireplace, install the hole for the fireplace opening in a single wallboard sheet, if possible. This will minimize the joints adjacent to the fireplace opening.

Tape wall board joints around the fireplace opening with fiberglass-mesh tape. It will provide a more crack-resistant joint than paper tape. Fill, smooth and finish wall joints with chemically setting-type joint compound. It will provide a more crack-resistant joint than air-drying lightweight compound.

### Painting

If desired finishing includes a painted wall, 100% acrylic latex with compatible primer is recommended around this appliance. Oil-based or standard acrylic paints may discolor due to heat exposure.

**WARNING! Risk of Fire! DO NOT** apply combustible materials beyond the minimum clearances. Comply with all minimum clearances to combustibles as specified in this manual. Overlapping materials could ignite and will interfere with proper operation of doors and louvers.

**WARNING! Risk of Fire! DO NOT** install drywall or other combustible materials directly onto the installed non-combustible board. Overlapping materials could ignite.

### Facing Material

- Facing and/or finishing materials must not interfere with air flow through louvers or decorative fronts.
- Facing and/or finishing materials must never overhang into the glass opening.
- Observe all clearances when applying combustible materials.

### Finishing - Hearth

See Inside Fit or Overlap Method sections to determine the necessary requirements for installation of a non-combustible hearth for this model. Only hearths made of non-combustible materials are allowed.

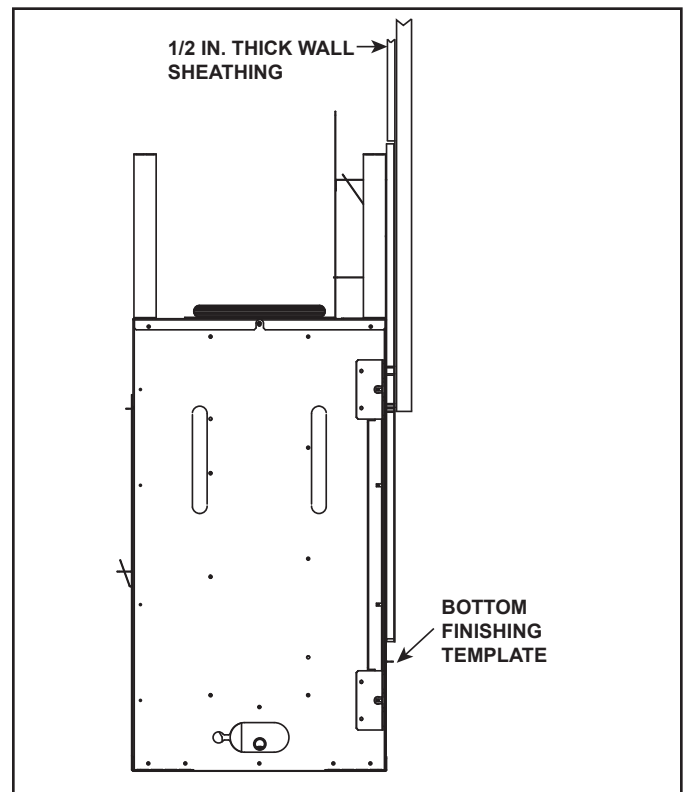
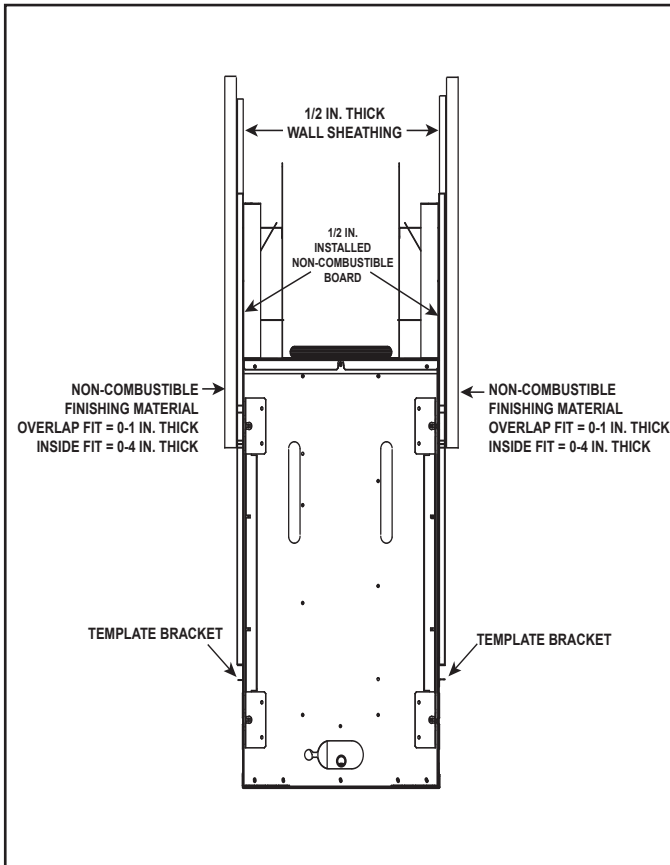


Figure 10.2 Finishing and Facing Materials - Single-sided Models



**Figure 10.3 Finishing Materials - See-Through Models**

Decorative facing material thickness is measured from the face of the installed non-combustible board. See Figure 10.2 and Figure 10.3.

The fronts for this appliance are compatible with non-combustible materials. See Figure 10.2 and Figure 10.3.

Refer to Section 1.E and 1.F of this manual for definitions and qualifications of non-combustible and combustible materials.

Specific requirements for each method if installation are described in this section.

Installation of finishing materials can be accomplished by either the “overlap” or “inside-fit” method, depending on what type of decorative front is to be installed. Overlap fit decorative fronts include the Four Square and Illusion. The Clean Face Trim Front (CFT) is an inside fit decorative front.

## Overlap Fit Finishing

### Non-Combustible Finish Materials

#### 0 - 1 inch thickness-Overlap Fit Method

All overlap fronts are designed to accept finish materials 0 inches to 1 inch thick. See Figure 10.3. If installing an overlap front (Four Square, Illusion), the finishing material will be placed up to the bottom edge of the finishing template.

**WARNING! Risk of Fire! DO NOT** apply combustible materials beyond the minimum clearances. Comply with all minimum clearances to combustibles as specified in this manual. Overlapping materials could ignite.

**NOTICE:** This one inch maximum not only includes the decorative finish materials (marble, tile, slate, etc) but also the thin set, lath and adhesive used to attach the decorative finish material.

1. The non-combustible finish material can be installed up to the fireplace opening on the top and sides. Do not cover rectangular access holes. See Figure 10.4 and 10.5.

**WARNING! Risk of Fire! DO NOT** cover rectangular holes on bottom access panel when installing overlap fronts.

• If a Clean Face Trim (CFT) front has been installed and is to be replaced by a front with an overlap fit, the finishing material must be removed to reveal the eight rectangular holes on the bottom access panel.

• Overheating and fire could occur.

2. Remove finishing template from bottom access panel.
3. Follow instructions provided with decorative front for installation.

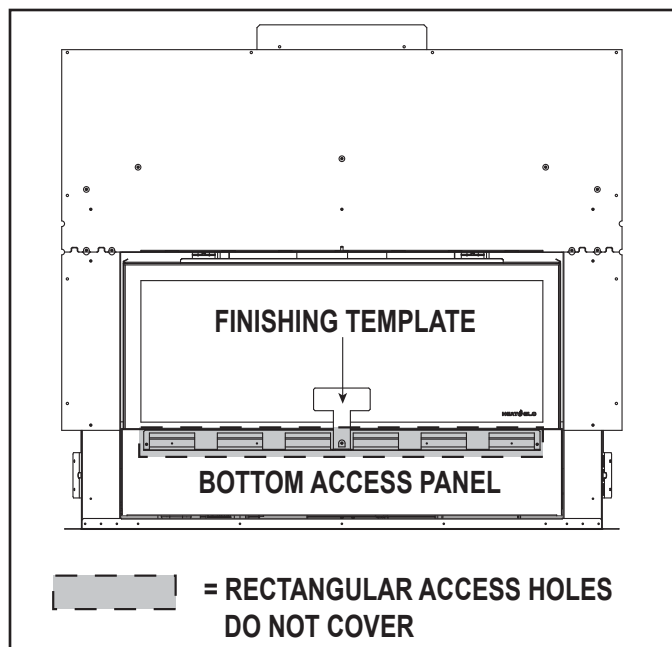


Figure 10.4 Non-Combustible Finish Material Diagram for 0-1 Inch Thick Overlap Fit Method

### Finishing - Non-Combustible Hearth - Overlap Fit

- A non-combustible hearth may be installed at the same level as the bottom of the appliance or lower. It may not cover any part of the appliance. See Figure 10.6.

**WARNING! Risk of Fire! DO NOT** allow any part of appliance to be covered by hearth or floor.

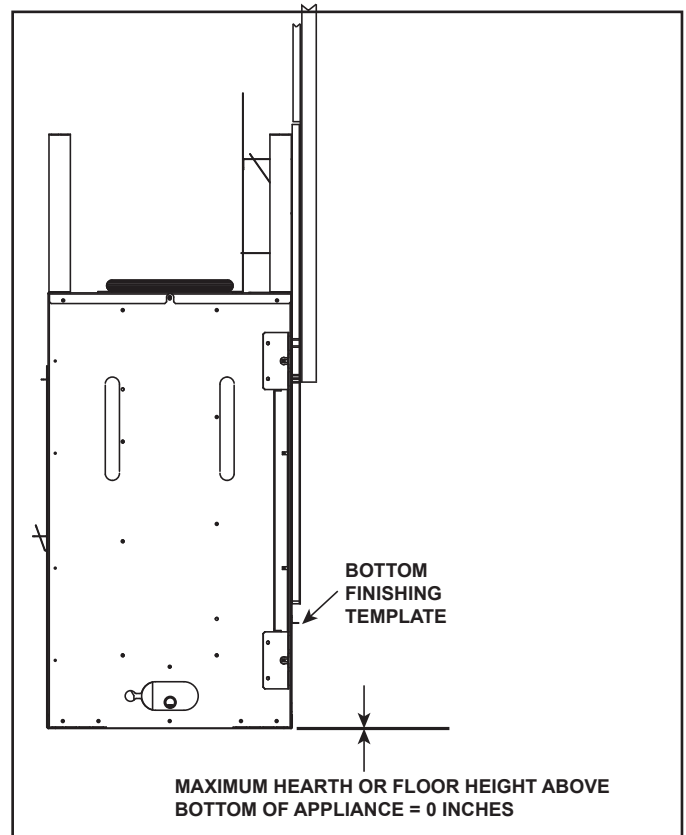


Figure 10.5 Finishing and Facing Materials - Overlap Fit

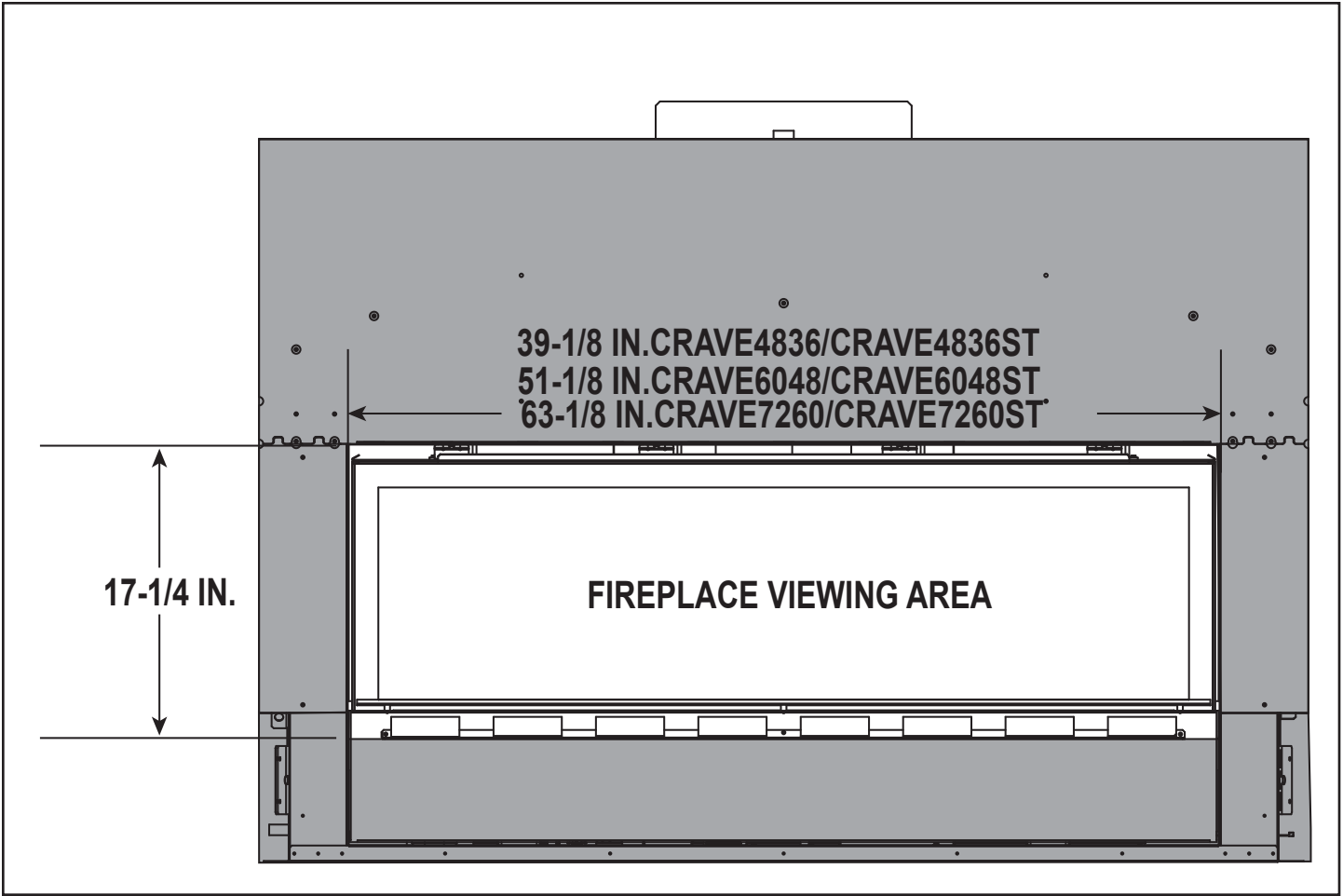


Figure 10.6 Finished Opening Dimensions - Overlap Fit Method

## Inside Fit Finishing

### Non-Combustible Finish Materials Clean Face Trim (CFT) Front Only 0 Inches to 1 Inch Thick Inside Fit Method

**Note:** When a Clean Face Trim decorative front is installed, the rectangular holes in bottom access panel will be covered.

**NOTICE:** This one inch maximum not only includes the decorative finish materials (marble, tile, slate, etc) but also the thin set, lath and adhesive used to attach the decorative finish material.

The Clean Face Trim decorative front is approved for inside fit applications. When using non-combustible finishing materials 0-1 inch thick, follow the instructions below. Refer to Section 1.E and 1.F of this manual for definition and qualifications and definition of non-combustible and combustible materials.

1. Remove finishing template from bottom access panel.
2. Install finishing material to the top ledge of the bottom access panel, covering the eight rectangle holes in the access panel. See Figure 10.1 for screw length requirements.
3. Install trim ring onto the wall. The trim ring acts as a finishing template in this application. Finishing materials may not extend past the outside edge of the trim ring.
4. Follow instructions provided with decorative front for installation.

#### **WARNING! Risk of Fire!**

- If a Clean Face Trim (CFT) front has been installed and is to be replaced by a front with an overlap fit, the finishing material must be removed to reveal the eight rectangular holes on the bottom access panel.
- Over heating and fire could occur.

### Non-Combustible Finish Materials Clean Face Trim (CFT) Front Only 1 Inch to 4 Inches Thick Inside Fit Method

Finishing material greater than one inch thick is only approved for non-combustible materials with a Clean Face Trim front only. Refer to Section 1.E and 1.F of this manual for definition and qualifications and definition of non-combustible and combustible materials.

**WARNING! Risk of Fire! DO NOT** apply combustible materials beyond the minimum clearances. Comply with all minimum clearances to combustibles as specified in this manual. Overlapping materials could ignite.

1. Remove finishing template from bottom access panel.
2. Install trim ring onto the wall. The trim ring acts as a finishing template in this application. Finishing materials may not extend past the outside edge of the trim ring.

**NOTICE:** If finishing extends past the inside opening of the outer trim ring, the decorative front will not fit.

3. Install non-combustible finishing material up to the outer edges of the trim ring. See Figure 10.1 for screw length requirements.
4. Follow instructions provided with decorative front for installation.

#### **WARNING! Risk of Fire!**

- If a Clean Face Trim (CFT) front has been installed and is to be replaced by a front with an overlap fit, the finishing material must be removed to reveal the eight rectangular holes on the bottom access panel.
- Over heating and fire could occur.

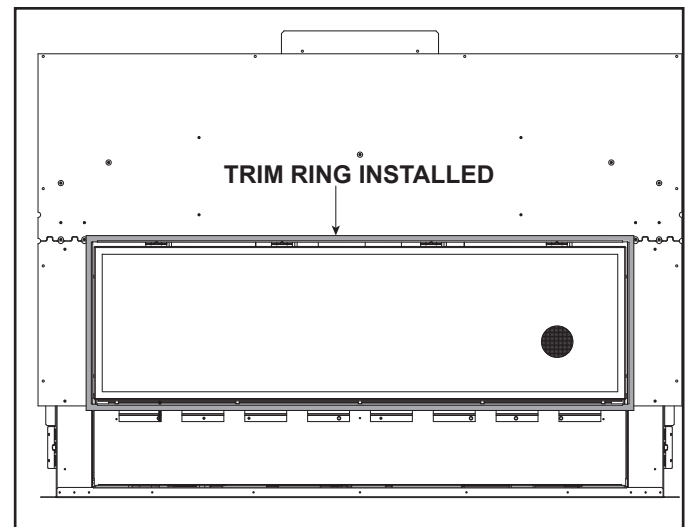


Figure 10.7 Non-Combustible Finish Material Diagram for  
1-4 Inch Thick Inside Fit Method

## Finishing - Non-Combustible Hearth (CFT) Fronts- Inside Fit

A non-combustible hearth may be installed in front of the appliance only if the inside fit finishing method with CFT doors is used.

1. Install trim ring.
2. Non-combustible hearth material may be placed up to the bottom edge of the trim ring. The hearth may be a maximum of twelve inches in depth.

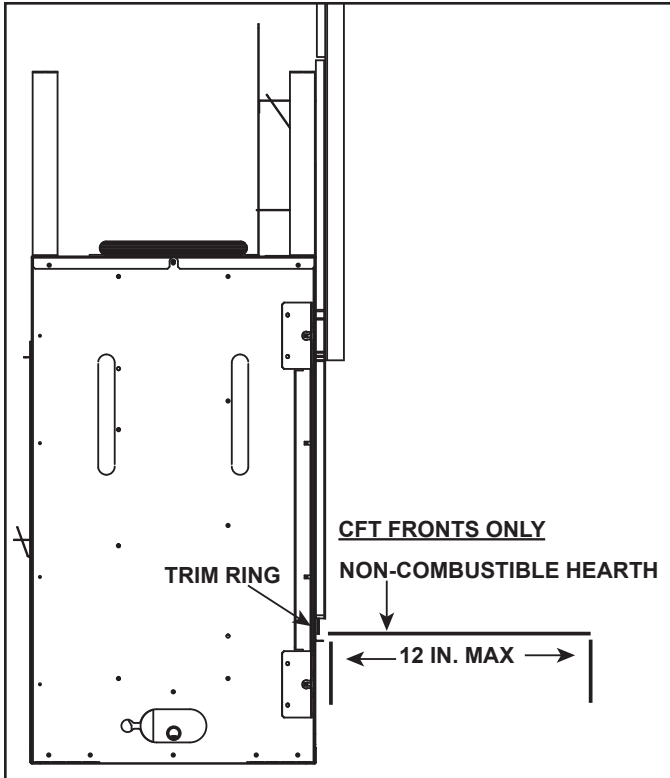


Figure 10.8 Finishing and Facing Materials - Inside Fit

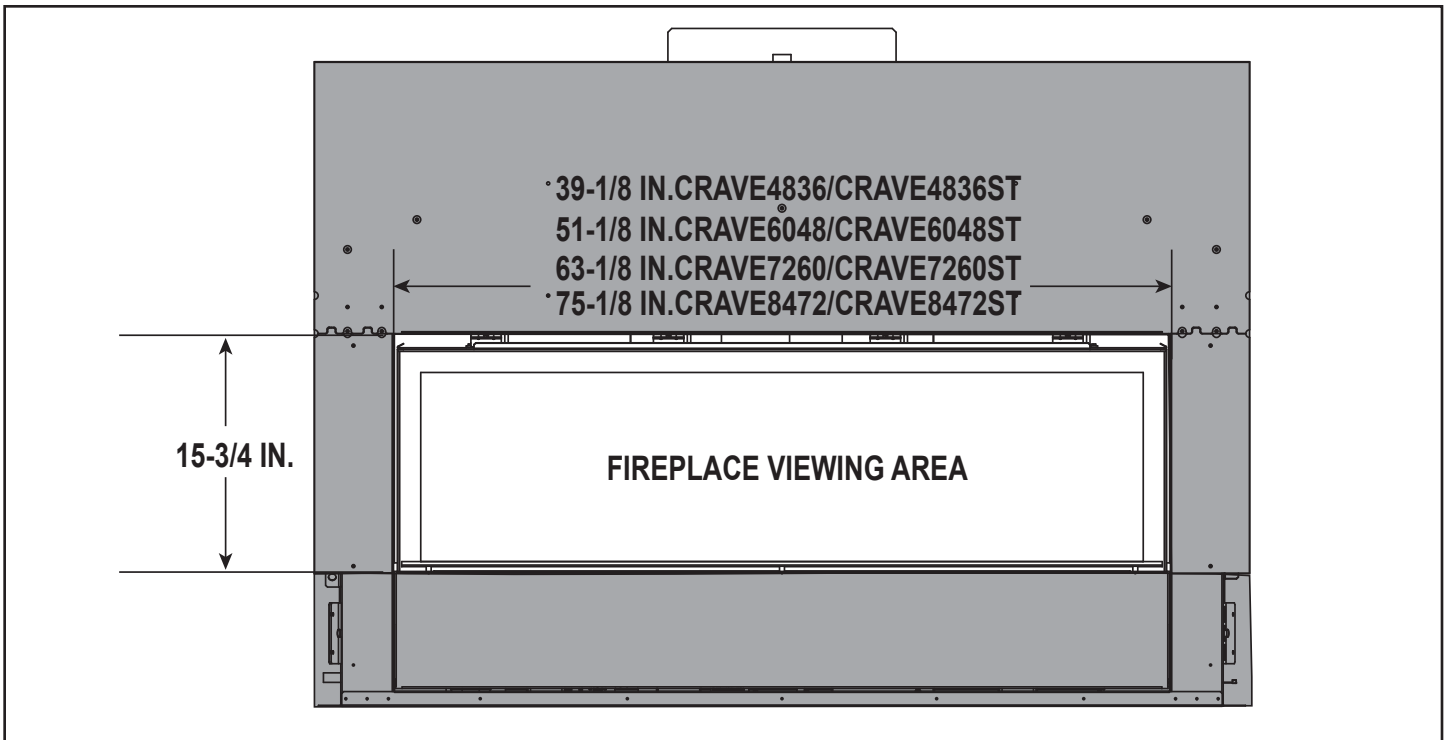


Figure 10.9 Finished Opening Dimensions - Inside Fit Method

## B. Mantel and Wall Projections

**WARNING! Risk of Fire!** Comply with all minimum clearances to combustibles as specified. Framing closer than the minimums listed must be constructed entirely of noncombustible materials (i.e., steel studs, concrete board, etc.)

Note: For non-combustible fireplace finish material (marble, stone, etc) specifications refer to Section 10.A.

### Combustible Mantels

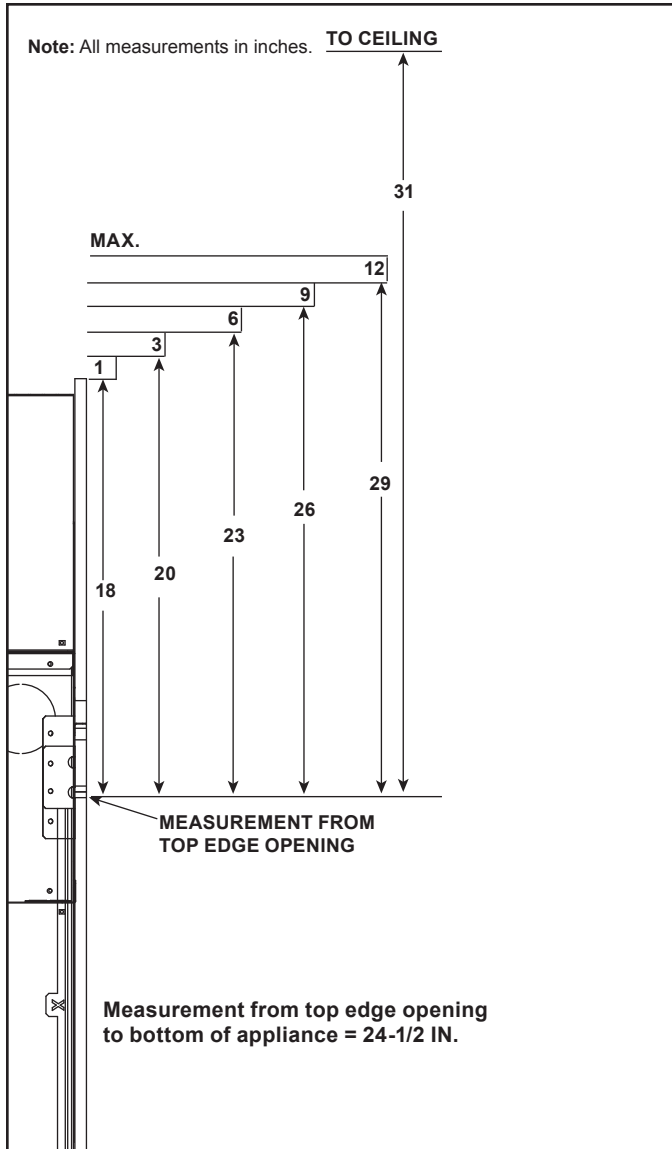


Figure 10.10 Minimum Vertical and Maximum Horizontal Dimensions of Combustibles - CRAVE4836 and CRAVE6048

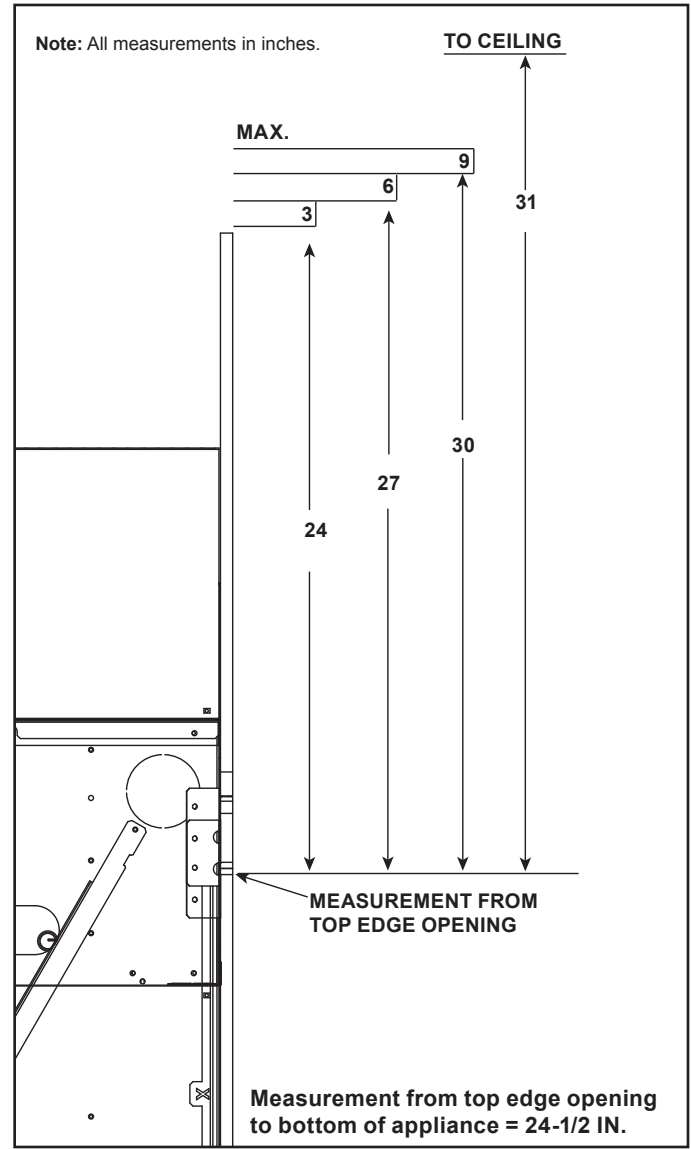
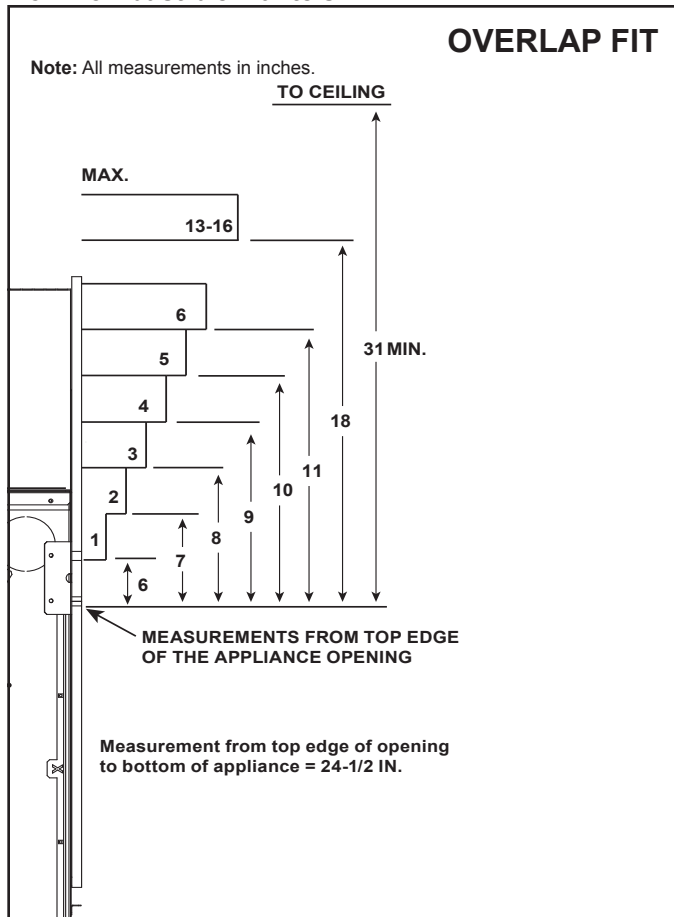


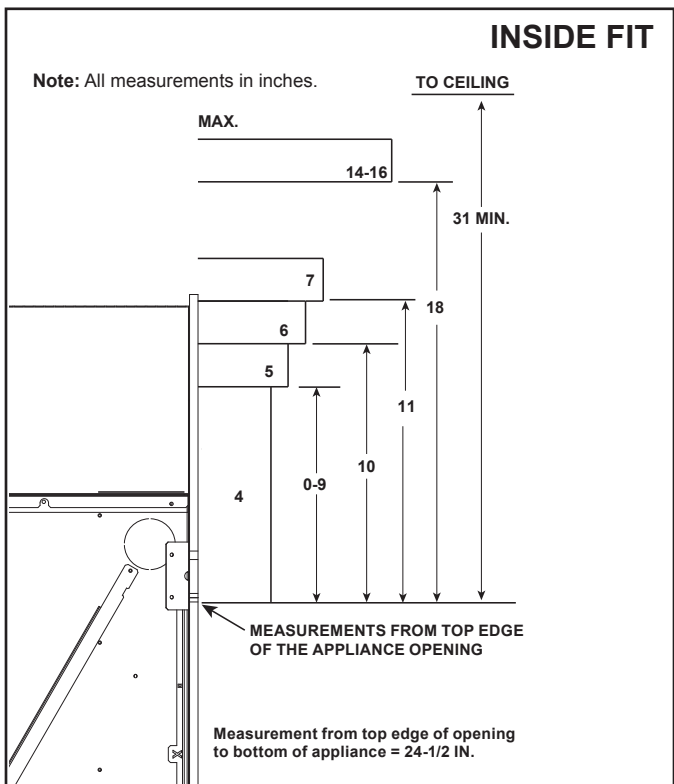
Figure 10.11 Minimum Vertical and Maximum Horizontal Dimensions of Combustibles - CRAVE7260 and CRAVE8472



**Non-Combustible Mantels**

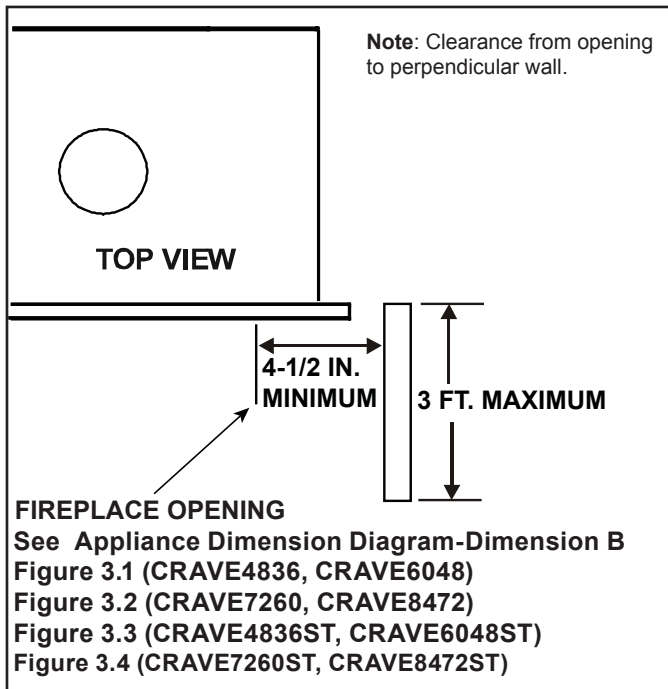


**Figure 10.12 Minimum Vertical and Maximum Horizontal Dimensions of Non-Combustibles - Overlap Fit Finishing**

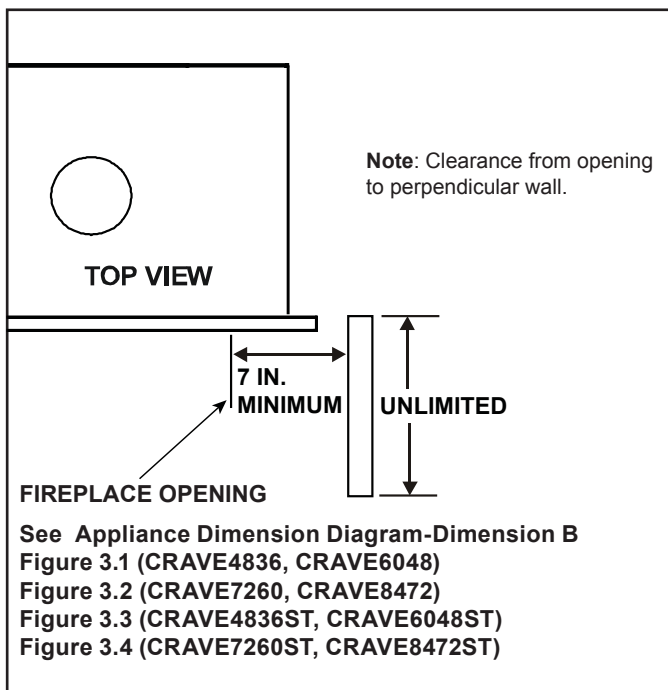


**Figure 10.13 Minimum Vertical and Maximum Horizontal Dimensions of Non-Combustibles - Inside Fit Finishing**

**Mantel Legs Or Wall Projections Extending Past The Face Of The Fireplace (Combustible or Non-Combustible)**



**Figure 10.14 Mantel Leg or Wall Projections (Acceptable on both sides of opening)**



**Figure 10.15 Mantel Leg or Wall Projections (Acceptable on both sides of opening)**

## C. Decorative Front Dimensions for Finishing

**WARNING! Risk of Burns!** A decorative front is required for this model. **DO NOT** operate this appliance without a decorative front in place.

Only decorative fronts certified for use with this appliance model may be used. Contact your dealer for a list of decorative fronts that may be used.

The doors approved for use with this appliance have been designed to be installed by two methods: Overlap Fit or Inside Fit. Before beginning the installation, it is important to determine which method will be used.

**Overlap Fit Doors (Four Square/Illusion):** These doors have been designed to be installed over finishing material up to one inch thick. Finishing materials may be a maximum of 1 in. thick. Stop finishing material flush with opening on top and sides. Stop finishing material flush with finishing template on bottom.

**Inside Fit Doors (Clean Face Trim front):** These doors are installed flush with the non-combustible finishing material up to four inches thick. Finishing materials may be a maximum of 4 in. thick. Stop finishing material flush with opening.

**Note:** See appliance Owner's Manual for TV mounting guidelines.

# 11 Appliance Setup

## A. Fixed Glass Assembly

**WARNING! Risk of Asphyxiation!** Handle fixed glass assembly with care. Inspect the gasket to ensure it is undamaged and inspect the glass for cracks, chips or scratches.

- **DO NOT** strike, slam or scratch glass.
- **DO NOT** operate fireplace with glass removed, cracked, broken or scratched.
- Replace as a complete assembly.

### Removing Fixed Glass Assembly

1. Remove the decorative front from fireplace and set aside on work surface.
2. Locate the glass latches that are on the upper edge of the glass frame of the appliance. See Figure 11.1.
3. Use both index fingers to release the glass clips.
4. Allow glass to tilt forward. Grasp glass on the upper return lip of glass frame and lift up and out. The glass should lift easily out of the bottom retaining lip.

### Replacing Fixed Glass Assembly

1. Locate retaining lip on lower front face of firebox.
2. Place glass assembly into retaining lip end. Tilt top of glass assembly toward fireplace.
3. Assure proper left to right placement of glass and engage all four spring latches.

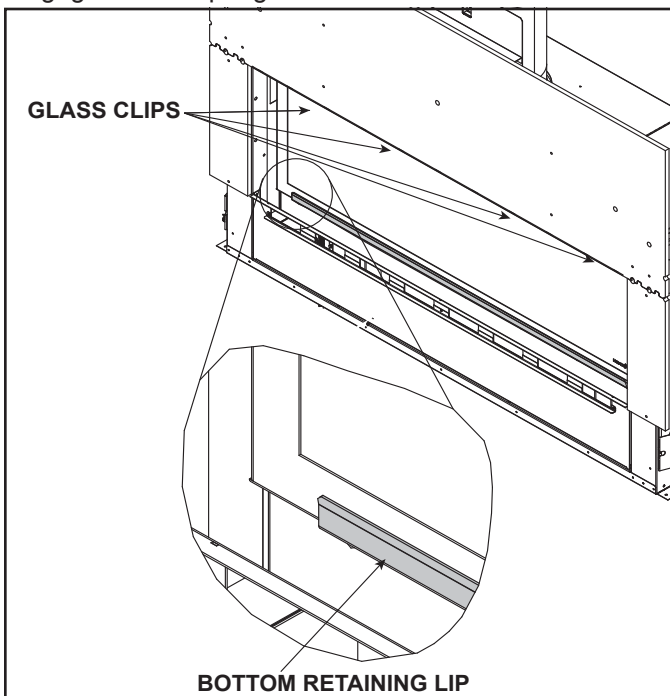


Figure 11.1 Fixed Glass Assembly

## B. Remove the Shipping Materials/Install Vanity Panel

Remove shipping materials from inside or underneath the firebox. Verify all components are with the fireplace. Unwrap the vanity panel and replace in the same location as shown in Figure 11.2.

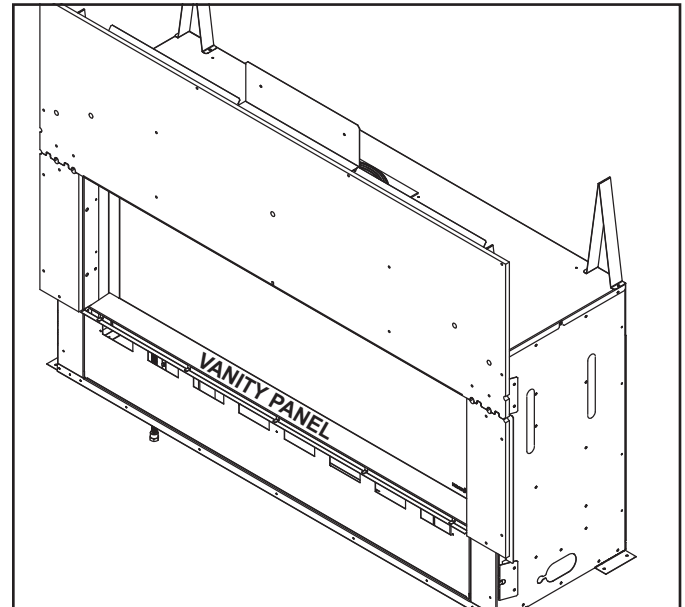


Figure 11.2 Vanity Panel Location

## C. Clean the Appliance

Clean/vacuum any sawdust that may have accumulated inside the firebox or underneath in the control cavity.

## D. Install Media

A media kit is included with the CRAVE models. Install rock media according to these instructions.

**WARNING! Choking Hazard!** Keep media out of reach of children.

**CAUTION! Risk of Burns!** The fireplace should be turned off and cooled before media is installed.

**CAUTION! Risk of Cuts, Abrasions or Flying Debris.** Wear protective gloves and safety glasses during installation. Sheet metal edges are sharp.

### Cleaning the Media

During shipment of the media, dust and debris can accumulate. It is recommended that the media be rinsed thoroughly with water to remove dust and small particles. An easy method to clean the media is to place the media into a pail and rinse thoroughly. Spread the media out over paper towels and allow the media to dry before installing them into the fireplace.

### INSTALLATION


1. Choose 7 - 10 round pieces of media approximately 1/2 inch in size and set them aside. These will be used later to conceal the pilot end of the burner. Reference Figure 1 for choosing round pieces of glass.

**WARNING! Risk of Explosion! DO NOT** put any flat media pieces larger than 1/2 inch in diameter near pilot. Delayed ignition could occur. Use only round 1/2 inch pieces near pilot.



Figure 11.3. Selecting Flat Media for Pilot Cover.

2. The included media placement jig, shown in Figure 2, MUST be used any time media are placed on the burner to ensure that none end up in the burner lighting area. Verify that the media placement jig is correctly installed in place in the appliance. See Figure 11.4.

<b>⚠ WARNING</b>	
	Delayed Ignition Risk
	• Place media according to instructions.
	• Do NOT place media in area in front of pilot
	• Do NOT place media in a position that they may fall into area in front of pilot.
	• Do NOT use any media other than the media supplied with this fireplace.
• Do NOT exceed one layer of media on base pan.	
Fireplace will not function properly. Delayed ignition may occur.	

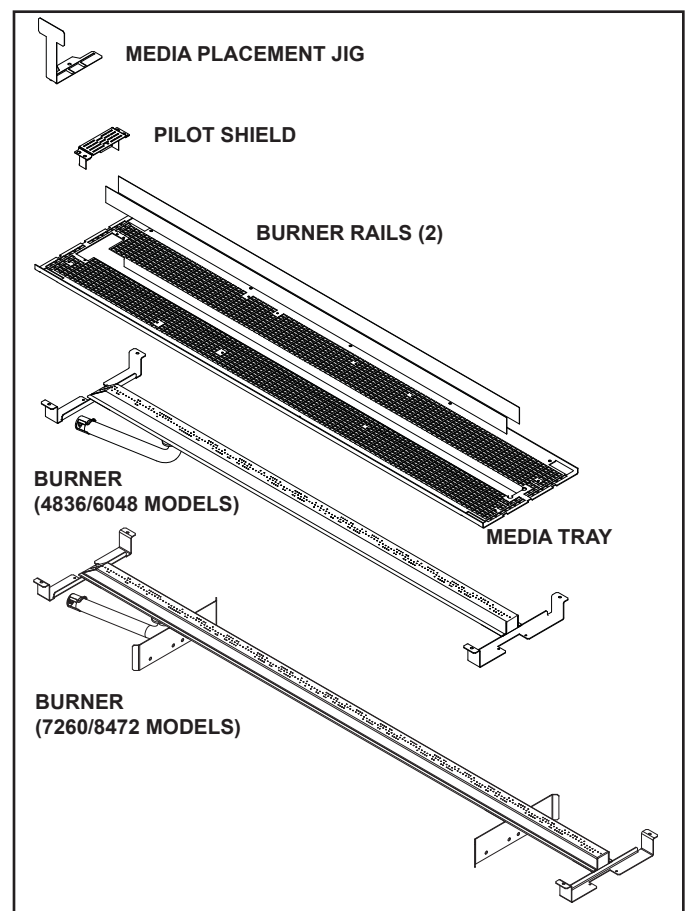


Figure 11.4. Media Tray Components

3. The media placement jig must remain in place while media is placed on the media tray and around the pilot bracket.

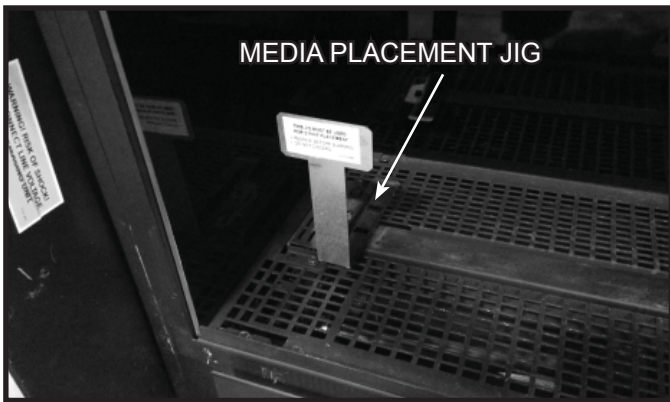


Figure 11.5. Media Placement Jig in Place

- Place an even layer of media around the media tray as shown in Figure 11.6. The CRAVE burner rails should be covered with media. **DO NOT place media on media placement jig.**
- Continue to place an even amount of media over the entire media tray.

<b>⚠ WARNING</b>	
	Risk of Asphyxiation or Fumes.
	<ul style="list-style-type: none"> <li>Place media according to instructions.</li> <li>Do NOT place media in area between glass and firebox.</li> <li>Do NOT place media in a position that they may fall into area between glass and firebox.</li> <li>Do NOT use any media other than the media supplied with this fireplace.</li> </ul>
	Fireplace will not function properly.
	Gas leak may occur.



Figure 11.6. Media Placement Jig in Place

- Remove the screw, noted in Figure 11.7, from the media placement jig and carefully lift the jig out of the appliance. **DO NOT allow any pieces of media to fall into the area in front of the pilot.**

**WARNING! Risk of Explosion. DO NOT place media directly in front of the pilot assembly. Delayed ignition could occur.**

- Place the round media set aside in Step 1 over the pilot shield and areas uncovered by removing the media placement jig. **DO NOT allow any media in the 1 inch area shown in Figure 11.8 and Figure 11.9.**

**WARNING! Risk of Explosion. DO NOT place media directly in front of the pilot assembly. Delayed ignition could occur.**

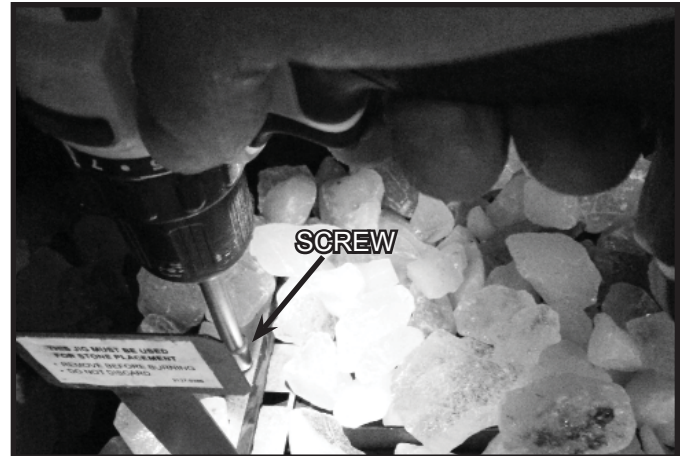


Figure 11.7. Remove Media Placement Jig



Figure 11.8. Media Installed

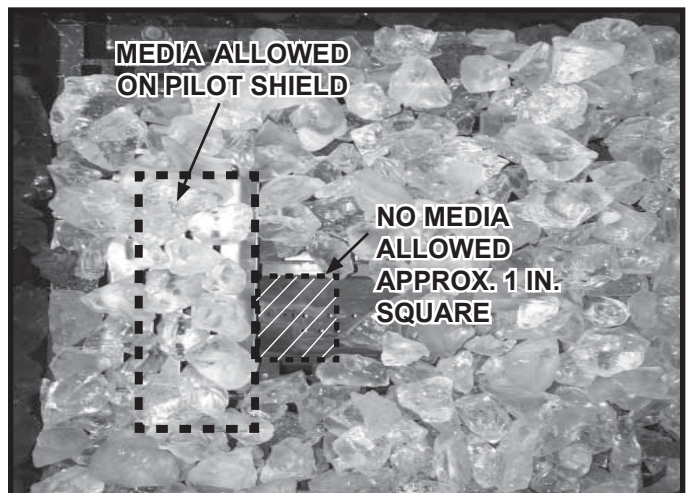


Figure 11.9. Pilot Shield Media installation.

## Fogging Option

7. If desired, the media can be fogged using a high temperature black paint. See below for fogging tips. Prior to painting, take precautions to prevent any overspray from reaching the pilot assembly.
  - Apply paint with the LED lights turned on. This will help you avoid over fogging or under fogging.
  - Reduce the lighting in the room while applying the paint.
  - Fog the media to the desired look.



Figure 11.10 Fogging the Media

8. Place the glass frame assembly back on the appliance according to the instructions provided in the appliance installation manual. Assure that there is no media between the glass and the firebox. Media in this area will prevent the glass gasket from sealing.
9. Install bottom glass shield between glass and glass frame. See Figure 11.11.

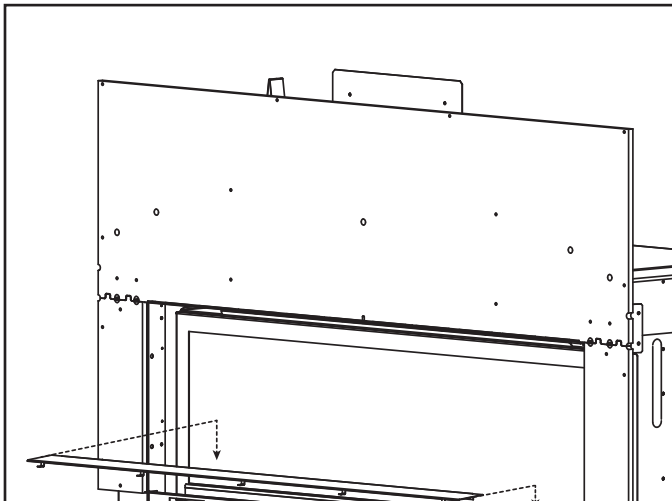


Figure 11.11. Install Bottom Glass Shield

## TROUBLESHOOTING

After the initial start up burn, it may be necessary to adjust the media placement to achieve the best flame appearance. While flame height variation is normal, there may appear to be higher peaks in some areas and low flame peaks in other areas.

If the flame height appears to be excessively high in some spots, applying more media to these areas on top of the burner will help even out the flames. Spreading the media as evenly as possible is the most effective way to achieve optimal flame appearance and the most even flame heights. One or more test burns may be required to watch the flames mature and see how even they look before making adjustments.

Avoid using media pieces larger than two inches in diameter, these can be disruptive to the flame patterns. If you find extra large media pieces, discard.

## E. Install Log Set

An optional log set is available for use with the CRAVE models. Install the log set per instructions included with kit.

# 12 Reference Materials

## A. Vent Components Diagrams

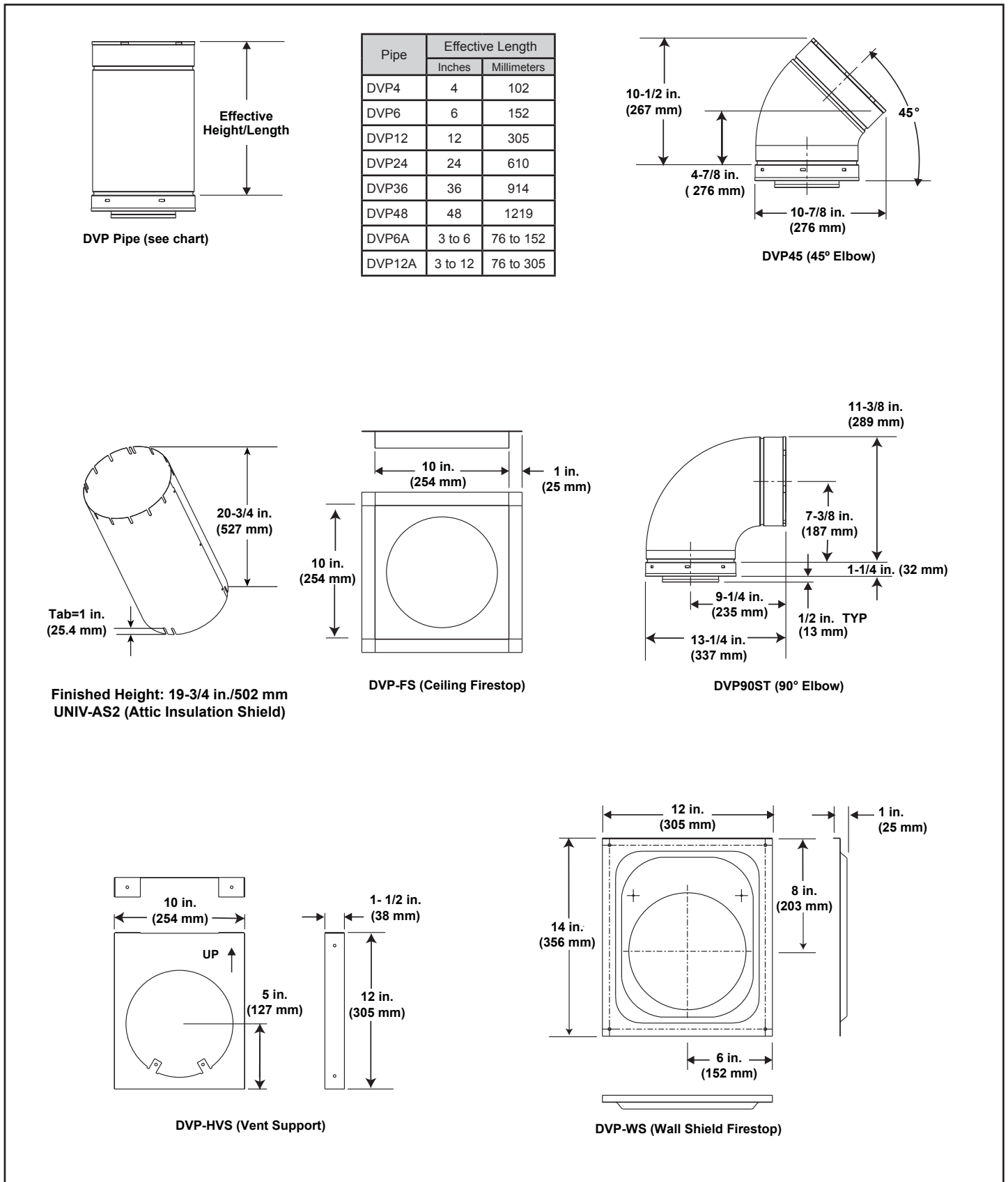
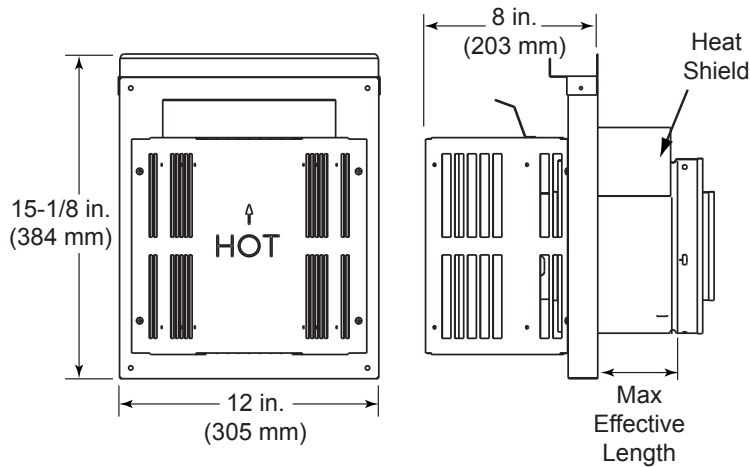


Figure 12.1 DVP Vent Components

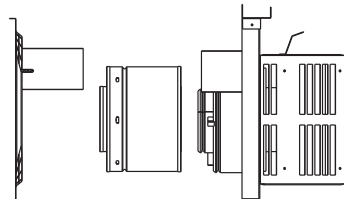
## A. Vent Components Diagrams (continued)

Note: Heat shields MUST overlap by a minimum of 1-1/2 in. (38 mm). **The heat shield is designed to be used on a wall 4 in. to 7-1/4 in. (102 mm to 184 mm) thick.** If wall thickness is less than 4 in. (102 mm) the existing heat shields must be field trimmed. If wall thickness is greater than 7-1/4 in. (184 mm) a DVP-HSM-B will be required.

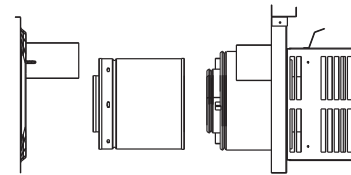


**DVP-TRAP**  
Horizontal Termination Cap

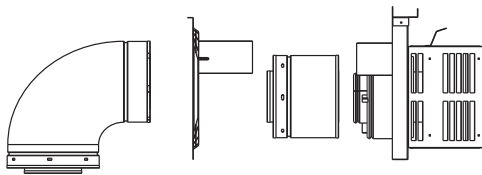
Term Cap	Minimum Effective Length	Maximum Effective Length
Trap1	3-1/8 in.	4-5/8 in.
	79 mm	117 mm
Trap2	5-3/8 in.	9-3/8 in.
	137 mm	238 mm



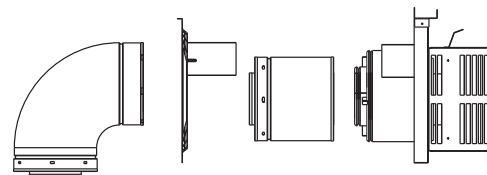
**DVP-TRAP1**



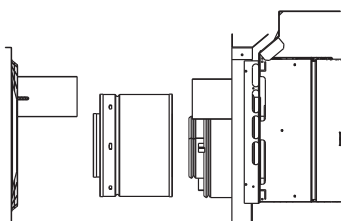
**DVP-TRAP2**



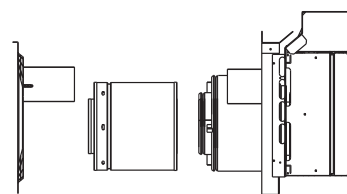
**DVP-TRAPK1**



**DVP-TRAPK2**



**DVP-HPC1**



**DVP-HPC2**

Figure 12.2 DVP Vent Components



## A. Vent Components Diagrams (continued)

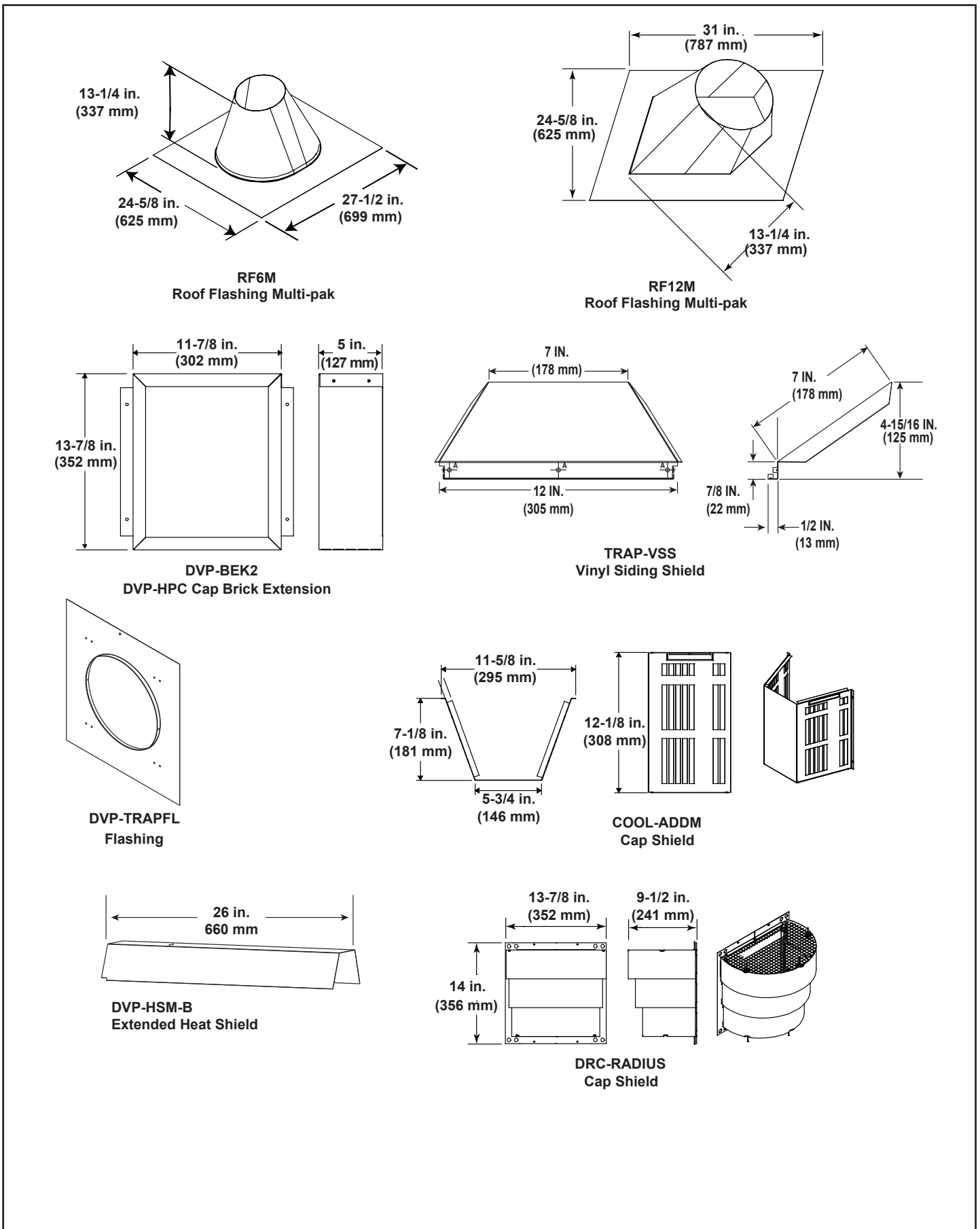


Figure 12.3 DVP Vent Components

## A. Vent Components Diagrams (continued)

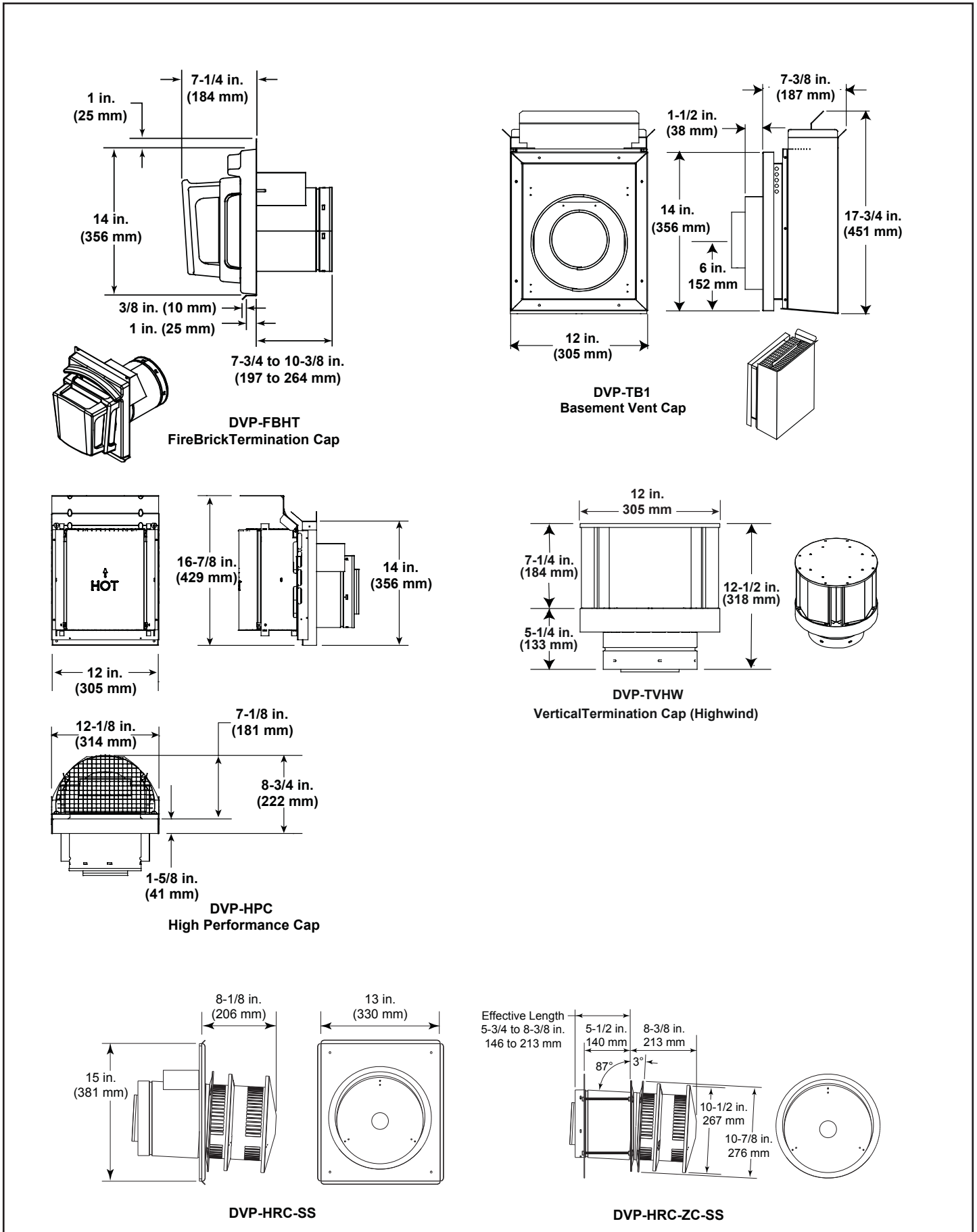
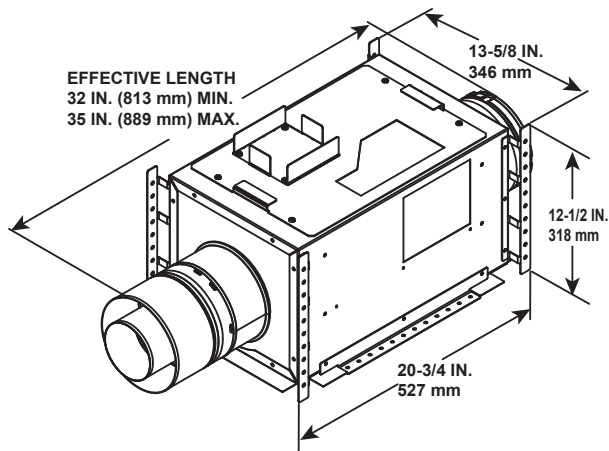


Figure 12.4 DVP Vent Components



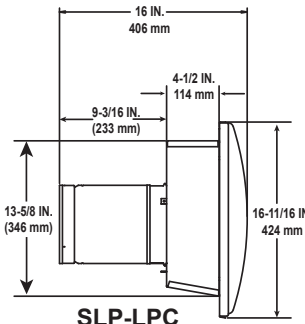
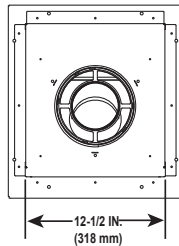
**PVI-SLP**  
Power Vent Inline

Optional Wire Harness	
DESCRIPTION	PART NUMBER
10 ft. PV Wire Harness	PVI-WH10
20 ft. PV Wire Harness	PVI-WH20
40 ft. PV Wire Harness	PVI-WH40
60 ft. PV Wire Harness	PVI-WH60
80 ft. PV Wire Harness	PVI-WH80
100 ft. PV Wire Harness	PVI-WH100

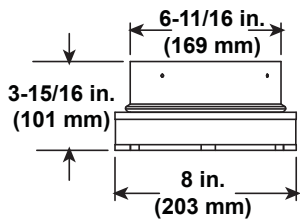
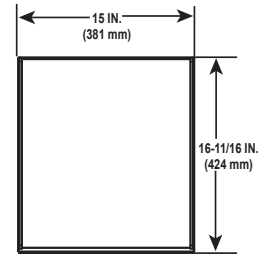
**Note:** Wire harnesses required to power the PVI-SLP connect to the appliance and are ordered separately from PVI-SLP. Contact your dealer to order.

**Note:** Use only approved termination caps with the PVI-SLP. See instructions included with PVI-SLP kit.

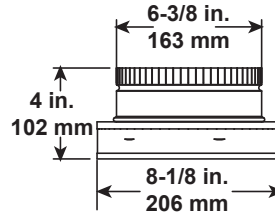
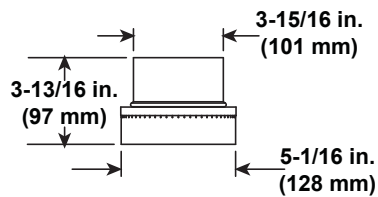
**Note:** SLP-LPC, SL-2DVP and DVP-2SL components must be accompanied by a PVI-SLP.



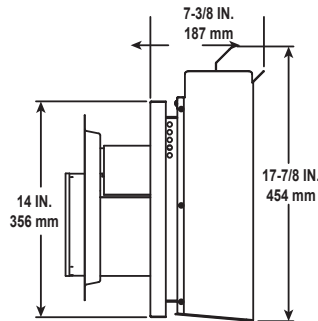
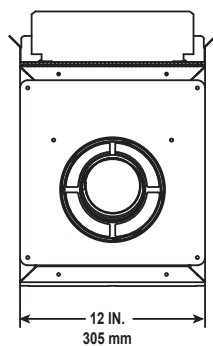
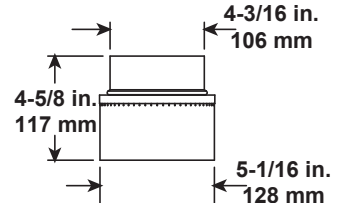
**SLP-LPC**  
SLP Low Profile Cap



**SL-2DVP**  
Adapter



**DVP-2SL**  
Adapter



**SLP-TB1**  
Basement Vent Cap

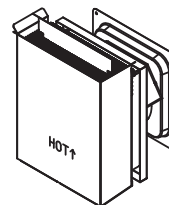
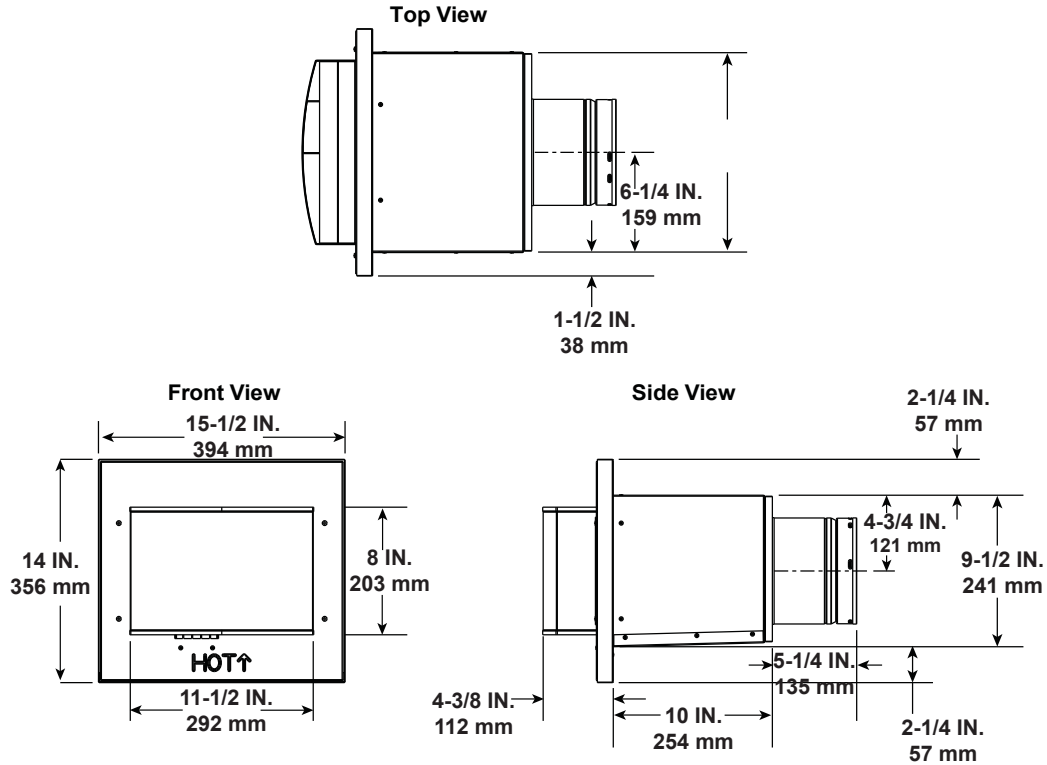


Figure 12.5 PVI-SLP Vent Components

## A. Vent Components Diagrams (continued)

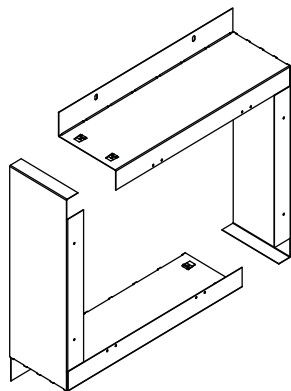


Required Wire Harness	
DESCRIPTION	PART NUMBER
10 FT PV Wire Harness	PVI-WH10
20 FT PV Wire Harness	PVI-WH20
40 FT PV Wire Harness	PVI-WH40
60 FT PV Wire Harness	PVI-WH60
80 FT PV Wire Harness	PVI-WH80
100 FT PV Wire Harness	PVI-WH100

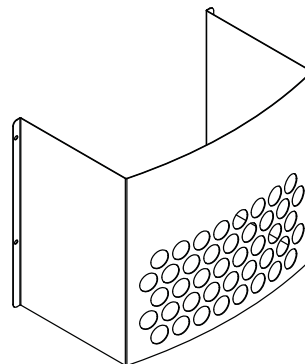
**Note:** Wire harnesses required to power the PVLP-SLP connect to the appliance and are ordered separately from PVLP-SLP. Contact your dealer to order.

**Note:** The PVLP-SLP requires a PVLP-CK be installed on this appliance. The PVLP-CK is ordered separately from the PVLP-SLP. Contact your dealer to order.

**Note:** A PVLP-HS heat shield is available and sold separately. Use if the PVLP-SLP is installed in a high traffic area.



**PVLP-BEK  
Brick Kit**



**PVLP-HS  
Heat Shield**

Figure 12.6 PVLP-SLP Vent Components

## **B. Accessories**

### **Remote Controls, Wall Controls and Wall**

#### **Switches**

Follow the instructions supplied with the control installed to operate your fireplace:

For safety:

- Install a switch lock or a wall/remote control with child protection lockout feature.
- Keep remote controls out of reach of children.

Contact your dealer if you have questions.

#### **Optional Heat-Zone® Kit**

Follow the instruction supplied with the kit for operation.

- Preparation for installation of Heat-Zone® Kit is discussed in Section 5.E.

Contact your dealer if you have questions.

Heatilator, a brand of Hearth & Home Technologies  
7571 215<sup>th</sup> Street West, Lakeville, MN 55044  
[www.heatilator.com](http://www.heatilator.com)

Please contact your Heatilator dealer with any questions or concerns.  
For the location of your nearest Heatilator dealer,  
please visit [www.heatilator.com](http://www.heatilator.com).

*Printed in U.S.A. - Copyright 2016*