

Installation Manual

Installation and Appliance Setup

INSTALLER: Leave this manual with party responsible for use and operation.

OWNER: Retain this manual for future reference.

Contact your dealer with questions regarding installation, operation or service.

NOTICE: DO NOT discard this manual!

heatilator
The first name in fireplaces

Models:

ION-V7

ION-S7

ION-H7

GAS-FIRED

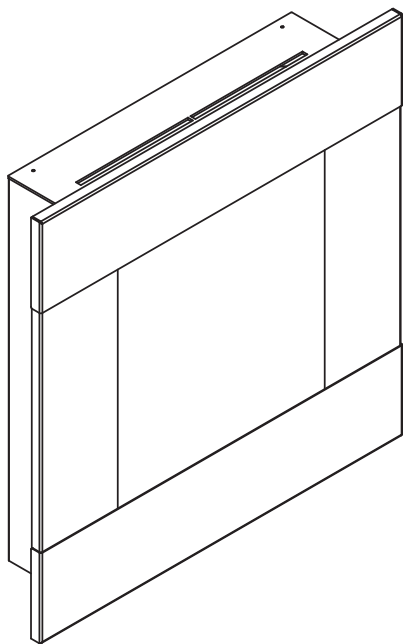

This appliance may be installed as an OEM installation in manufactured home (USA only) or mobile home and must be installed in accordance with the manufacturer's instructions and the *Manufactured Home Construction and Safety Standard, Title 24 CFR, Part 3280* in the United States, or the *Standard for Installation in Mobile Homes, CAN/CSA Z240 MH Series*, in Canada.

This appliance is only for use with the type(s) of gas indicated on the rating plate. This appliance is not convertible for use with other gases, unless a certified kit is used.

▲ WARNING:

FIRE OR EXPLOSION HAZARD

Failure to follow safety warnings exactly could result in serious injury, death, or property damage.

- **DO NOT** store or use gasoline or other flammable vapors and liquids in the vicinity of this or any other appliance.
- **What to do if you smell gas**
 - **DO NOT** try to light any appliance.
 - **DO NOT** touch any electrical switch. **DO NOT** use any phone in your building.
 - Leave the building immediately.
 - Immediately call your gas supplier from a neighbor's phone. Follow the gas supplier's instructions.
 - If you cannot reach your gas supplier, call the fire department.
- Installation and service must be performed by a qualified installer, service agency, or the gas supplier.

! DANGER



HOT GLASS WILL CAUSE BURNS.

DO NOT TOUCH GLASS UNTIL COOLED.

NEVER ALLOW CHILDREN TO TOUCH GLASS.

A barrier designed to reduce the risk of burns from the hot viewing glass is provided with this appliance and shall be installed for the protection of children and other at-risk individuals.

In the Commonwealth of Massachusetts installation must be performed by a licensed plumber or gas fitter.

See Table of Contents for location of additional Commonwealth of Massachusetts requirements.

▲ Safety Alert Key:

- **DANGER!** Indicates a hazardous situation which, if not avoided will result in death or serious injury.
- **WARNING!** Indicates a hazardous situation which, if not avoided could result in death or serious injury.
- **CAUTION!** Indicates a hazardous situation which, if not avoided, could result in minor or moderate injury.
- **NOTICE:** Used to address practices not related to personal injury.

Table of Contents

Installation Standard Work Checklist	3	7 Venting and Chimneys	
1 Product Specific and Important Safety Information		A. Assemble Vent Sections	36
A. Appliance Certification	4	B. Installing Slip Sections	37
B. Glass Specifications	4	C. Secure the Vent Sections	37
C. BTU Specifications	4	D. Disassemble Vent Sections	38
D. High Altitude Installations	4	E. Vertical Termination Requirements	39
E. Non-Combustible Materials Specification	4	F. Horizontal Termination Requirements	41
F. Combustible Materials Specification	4	8 Electrical Information	
G. Electrical Codes	4	A. General Information	42
H. Requirements for the Commonwealth of Massachusetts	5	B. Wiring Requirements	43
2 Getting Started		9 Gas Information	
A. Design and Installation Considerations	6	A. Fuel Conversion	44
B. Tools and Supplies Needed	6	B. Gas Pressure	44
C. Inspect Appliance and Components	6	C. Gas Connection	44
→ D. Installation Methods: On-Wall or In-Wall	7	D. High Altitude Installations	44
3 Framing and Clearances		E. Air Shutter Setting	45
A. Appliance/Decorative Front Dimension Diagrams	8	10 Finishing (On-Wall Installation)	
B. Clearance to Combustibles	12	→ A. Facing and Finishing - Four Square Decorative Fronts	46
C. Constructing the Appliance Chase	13	→ B. Mantel Projections (All Fronts)	47
D. Floor Protection	13	→ C. Mantel Leg and Wall Projections	48
E. Clearances (On-Wall and In-Wall)	14	11 In-Wall Installation	
→ F. Clearances - Venting with an Elbow Directly Off the Back of Appliance	15	→ A. Wall and Appliance Preparation	49
4 Termination Location and Vent Information		B. In-Wall - Minimum Combustible Facing Clearances	53
A. Vent Termination Minimum Clearances	16	C. In-Wall - Minimum Non-Combustible Facing Clearances	54
B. Chimney Diagram	17	→ D. In-Wall Mantel and Wall Projections	55
C. Approved Pipe	18	→ E. In Wall - Finishing	56
D. Use of Elbows	18	12 Appliance Setup	
E. Measuring Standards	19	A. Removing Fixed Glass Assembly	57
F. Vent Diagrams	19	B. Remove the Shipping Materials	57
5 Vent Clearances and Framing		C. Clean the Appliance	57
A. Pipe Clearances to Combustibles	27	D. Decorative Fronts/Mesh	57
B. Wall Penetration Framing/Firestops	27	13 Reference Materials	
C. Ceiling Firestop/Floor Penetration Framing	28	A. Vent Components Diagrams	58
D. Install Attic Insulation Shield	28	B. Accessories	63
6 Appliance Preparation			
A. Vent Collar Preparation - Sealing the Firestop	29		
B. Install Appliance Corrugated Template (On-Wall Installation)	30		
C. Install Appliance Outer Wrap (On-Wall Installation)	33		
D. Install Appliance Into Outer Wrap (On-Wall Installation)	35		

→ = Contains updated information.

Installation Standard Work Checklist

ATTENTION INSTALLER: Follow this Standard Work Checklist

This standard work checklist is to be used by the installer in conjunction with, not instead of, the instructions contained in this installation manual.

Customer: _____

Date Installed: _____

Lot/Address: _____

Location of Fireplace: _____

Installer: _____

Model (circle one): ION-V7 ION-S7 ION-H7

Dealer/Distributor Phone # _____

Serial #: _____



WARNING! Risk of Fire or Explosion! Failure to install appliance according to these instructions could lead to a fire or explosion.

Appliance Install

- | | YES | IF NO, WHY? |
|--|--------------------------|-------------|
| Verified that the area behind appliance is insulated and sealed as required. (Pg. 12) | <input type="checkbox"/> | _____ |
| Required non-combustible board installed.(In-Wall Installation only) (Section 11) | <input type="checkbox"/> | _____ |
| Verified clearances to combustibles. (Section 3) | <input type="checkbox"/> | _____ |
| Required In-Wall Kit installed if back of appliance outer wrap penetrates the sheetrock/finish wall material (In-Wall Installation only) | <input type="checkbox"/> | _____ |
| Verified appliance is installed a minimum of 4 inches above finished floor. (Pg. 13,14,49) | <input type="checkbox"/> | _____ |
| Verified fireplace is leveled and secured. (Pg. 33,52) | <input type="checkbox"/> | _____ |

Venting/Chimney Section 7 (Pg 36-41)

- | | | |
|--|--------------------------|-------|
| Venting configuration complies with allowable vent requirements. | <input type="checkbox"/> | _____ |
| Venting installed, locked and secured in place with proper clearances. | <input type="checkbox"/> | _____ |
| Interior/Exterior firestops installed and sealed (In-Wall Installation only). | <input type="checkbox"/> | _____ |
| Attic insulation shield installed. (Pg 28) | <input type="checkbox"/> | _____ |
| Terminations/Roof flashing installed and sealed. | <input type="checkbox"/> | _____ |
| Termination cap extension installed and sealed (In-Wall Installation only)(Section 11) | <input type="checkbox"/> | _____ |

Electrical Section 8 (Pg 42-43)

- | | | |
|--|--------------------------|-------|
| 120VAC unswitched power provided to the appliance. | <input type="checkbox"/> | _____ |
| Verified ON/OFF switch wires properly installed. | <input type="checkbox"/> | _____ |

Gas Section 9 (Pg 44-45)

- | | | |
|--|--------------------------|-------|
| Appliance configuration matches fuel type. | <input type="checkbox"/> | _____ |
| Was a conversion performed? | <input type="checkbox"/> | _____ |
| Leak check performed and inlet/outlet pressure verified. | <input type="checkbox"/> | _____ |
| Set air shutter for optimal flame appearance. | <input type="checkbox"/> | _____ |

Finishing Section 10 (Pg 46-48)

- | | | |
|--|--------------------------|-------|
| Combustible materials not installed in non-combustible areas. | <input type="checkbox"/> | _____ |
| Verified all clearances meet installation manual requirements. | <input type="checkbox"/> | _____ |
| Mantels and wall projections comply with installation manual requirements. | <input type="checkbox"/> | _____ |

Appliance Setup Section 12 (Pg 57)

- | | | |
|--|--------------------------|-------|
| All packaging and protective materials are removed from inside/under /on the appliance. | <input type="checkbox"/> | _____ |
| Glass assembly installed and secured, glass retainers removed,gasket sealed. | <input type="checkbox"/> | _____ |
| Accessories installed properly. | <input type="checkbox"/> | _____ |
| Mesh, doors, or decorative front properly installed. | <input type="checkbox"/> | _____ |
| Manual bag and all of its contents are removed from inside/under the appliance and given to party responsible for use and operation. | <input type="checkbox"/> | _____ |
| Operated appliance. Verified no gas leaks exist and proper appliance operation. | <input type="checkbox"/> | _____ |

Hearth & Home Technologies recommends the following:

- Photographing the installation and copying this checklist for your file.
- This checklist remain visible at all times on the appliance until the installation is complete.

Comments: Further description of the issues, who is responsible (Installer/ Builder/ Other Trades, etc) and corrective action needed _____

Comments Communicated to party responsible _____ by _____ on _____
 (Builder / Gen. Contractor/) (Installer) (Date)

➔ = Contains updated information.

2276-982 8/14

1 Product Specific and Important Safety Information

A. Appliance Certification

MODELS: ION-V7, ION-S7, ION-H7
LABORATORY: Underwriters Laboratories, Inc. (UL)
TYPE: Direct Vent Heater
STANDARD: ANSI Z21.88-2014/CSA 2.33-2014

This product is listed to ANSI standards for “Vented Gas Fireplace Heaters” and applicable sections of “Gas Burning Heating Appliances for Manufactured Homes and Recreational Vehicles”, and “Gas Fired Appliances for Use at High Altitudes”.

NOTICE: *This installation must conform with local codes. In the absence of local codes you must comply with the National Fuel Gas Code, ANSI Z223.1-latest edition in the U.S.A. and the CAN/CGA B149 Installation Codes in Canada.*

NOT INTENDED FOR USE AS A PRIMARY HEAT SOURCE.
 This appliance is tested and approved as either supplemental room heat or as a decorative appliance. It should not be factored as primary heat in residential heating calculations.

B. Glass Specifications

This appliance is equipped with 5 mm ceramic glass. Replace glass only with 5 mm ceramic glass. Please contact your dealer for replacement glass.

C. BTU Specifications

Models (U.S. or Canada)		Maximum Input BTU/h	Minimum Input BTU/h	Orifice Size (DMS)
ION-V7 (NG)	(0-2000 FT)	14,250	8,200	#50
ION-V7 (LP)	(0-2000 FT)	13,350	8,500	#58
ION-S7 (NG)	(0-2000 FT)	18,800	10,900	.083 in.
ION-S7 (LP)	(0-2000 FT)	18,950	10,800	1.25 mm
ION-H7 (NG)	(0-2000 FT)	24,000	12,700	#42
ION-H7 (LP)	(0-2000 FT)	20,000	10,850	0.053 in.

D. High Altitude Installations

NOTICE: *If the heating value of the gas has been reduced, these rules do not apply. Check with your local gas utility or authorities having jurisdiction.*

When installing above 2000 feet elevation:

- In the USA: Reduce input rate 4% for each 1000 feet above 2000 feet.
- In CANADA: Input ratings are certified without a reduction of input rate for elevations up to 4500 feet (1370 m) above sea level. Please consult provincial and/or local authorities having jurisdiction for installations at elevations above 4500 feet (1370 m).

Check with your local gas utility to determine proper orifice size.

E. Non-Combustible Materials Specification

Material which will not ignite and burn. Such materials are those consisting entirely of steel, iron, brick, tile, concrete, slate, glass or plasters, or any combination thereof.

Materials that are reported as passing **ASTM E 136, Standard Test Method for Behavior of Materials in a Vertical Tube Furnace at 750 °C** shall be considered non-combustible materials.

F. Combustible Materials Specification

Materials made of or surfaced with wood, compressed paper, plant fibers, plastics, or other material that can ignite and burn, whether flame proofed or not, or plastered or unplastered shall be considered combustible materials.

G. Electrical Codes

NOTICE: *This appliance must be electrically wired and grounded in accordance with local codes or, in the absence of local codes, with National Electric Code ANSI/NFPA 70-latest edition or the Canadian Electric Code CSA C22.1.*

- A 110-120 VAC circuit for this product must be protected with ground-fault circuit-interrupter protection, in compliance with the applicable electrical codes, when it is installed in locations such as in bathrooms or near sinks.

Note: The following requirements reference various Massachusetts and national codes not contained in this document.

H. Requirements for the Commonwealth of Massachusetts

For all side wall horizontally vented gas fueled equipment installed in every dwelling, building or structure used in whole or in part for residential purposes, including those owned or operated by the Commonwealth and where the side wall exhaust vent termination is less than seven (7) feet above finished grade in the area of the venting, including but not limited to decks and porches, the following requirements shall be satisfied:

Installation of Carbon Monoxide Detectors

At the time of installation of the side wall horizontal vented gas fueled equipment, the installing plumber or gas fitter shall observe that a hard wired carbon monoxide detector with an alarm and battery back-up is installed on the floor level where the gas equipment is to be installed. In addition, the installing plumber or gas fitter shall observe that a battery operated or hard wired carbon monoxide detector with an alarm is installed on each additional level of the dwelling, building or structure served by the side wall horizontal vented gas fueled equipment. It shall be the responsibility of the property owner to secure the services of qualified licensed professionals for the installation of hard wired carbon monoxide detectors.

In the event that the side wall horizontally vented gas fueled equipment is installed in a crawl space or an attic, the hard wired carbon monoxide detector with alarm and battery back-up may be installed on the next adjacent floor level.

In the event that the requirements of this subdivision can not be met at the time of completion of installation, the owner shall have a period of thirty (30) days to comply with the above requirements; provided, however, that during said thirty (30) day period, a battery operated carbon monoxide detector with an alarm shall be installed.

Approved Carbon Monoxide Detectors

Each carbon monoxide detector as required in accordance with the above provisions shall comply with NFPA 720 and be ANSI/UL 2034 listed and IAS certified.

Signage

A metal or plastic identification plate shall be permanently mounted to the exterior of the building at a minimum height of eight (8) feet above grade directly in line with the exhaust vent terminal for the horizontally vented gas fueled heating appliance or equipment. The sign shall read, in print size no less than one-half (1/2) in. in size, "**GAS VENT DIRECTLY BELOW. KEEP CLEAR OF ALL OBSTRUCTIONS**".

Inspection

The state or local gas inspector of the side wall horizontally vented gas fueled equipment shall not approve the installation unless, upon inspection, the inspector observes carbon monoxide detectors and signage installed in accordance with the provisions of 248 CMR 5.08(2)(a)1 through 4.

Exemptions

The following equipment is exempt from 248 CMR 5.08(2)(a)1 through 4:

- The equipment listed in Chapter 10 entitled "Equipment Not Required To Be Vented" in the most current edition of NFPA 54 as adopted by the Board; and
- Product Approved side wall horizontally vented gas fueled equipment installed in a room or structure separate from the dwelling, building or structure used in whole or in part for residential purposes.

MANUFACTURER REQUIREMENTS

Gas Equipment Venting System Provided

When the manufacturer of Product Approved side wall horizontally vented gas equipment provides a venting system design or venting system components with the equipment, the instructions provided by the manufacturer for installation of the equipment and the venting system shall include:

- Detailed instructions for the installation of the venting system design or the venting system components; and
- A complete parts list for the venting system design or venting system.

Gas Equipment Venting System NOT Provided

When the manufacturer of a Product Approved side wall horizontally vented gas fueled equipment does not provide the parts for venting the flue gases, but identifies "special venting systems", the following requirements shall be satisfied by the manufacturer:

- The referenced "special venting system" instructions shall be included with the appliance or equipment installation instructions; and
- The "special venting systems" shall be Product Approved by the Board, and the instructions for that system shall include a parts list and detailed installation instructions.

A copy of all installation instructions for all Product Approved side wall horizontally vented gas fueled equipment, all venting instructions, all parts lists for venting instructions, and/or all venting design instructions shall remain with the appliance or equipment at the completion of the installation.

See Gas Connection section for additional Commonwealth of Massachusetts requirements.

2 Getting Started

A. Design and Installation Considerations

Heatilator direct vent gas appliances are designed to operate with all combustion air siphoned from outside of the building and all exhaust gases expelled to the outside. No additional outside air source is required.

Installation MUST comply with local, regional, state and national codes and regulations. Consult insurance carrier, local building inspector, fire officials or authorities having jurisdiction over restrictions, installation inspection and permits.

Before installing, determine the following:

- Where the appliance is to be installed.
- Whether the ION will be installed On-Wall or In-Wall (See Section 2.D),
- The vent system configuration to be used.
- Gas supply piping requirements.
- Electrical wiring requirements.
- Framing and finishing details.
- Whether optional accessories—devices such as a wall switch or remote control—are desired.



Installation and service of this appliance should be performed by qualified personnel. Hearth & Home Technologies suggests NFI certified or factory trained professionals, or technicians supervised by an NFI certified professional (www.nficertified.org).

Improper installation, adjustment, alteration, service or maintenance can cause injury or property damage. For assistance or additional information, consult a qualified service technician, service agency or your dealer.

B. Tools and Supplies Needed

Before beginning the installation be sure that the following tools and building supplies are available.

- | | |
|----------------------|------------------------|
| Tape measure | Framing material |
| Pliers | Hammer |
| Phillips screwdriver | Manometer |
| Gloves | Framing square |
| Voltmeter | Tin Snips |
| Plumb line | Safety glasses |
| Level | Reciprocating saw |
| Stud Finder | Flat blade screwdriver |
- Electric drill: 1/2 in. bit, 1/4 in. masonry bit (masonry wall installation only)
- Non-corrosive leak check solution
- 1/2 - 3/4 in. length, #6 or #8 Self-drilling screws
- Caulking material (300°F minimum continuous exposure rating)

C. Inspect Appliance and Components

- Carefully remove the appliance and components from the packaging.
- The vent system components and decorative doors and fronts may be shipped in separate packages.
- Report to your dealer any parts damaged in shipment, particularly the condition of the glass.
- **Read all of the instructions before starting the installation. Follow these instructions carefully during the installation to ensure maximum safety and benefit.**

WARNING! Risk of Fire or Explosion! Damaged parts could impair safe operation. DO NOT install damaged, incomplete or substitute components. Keep appliance dry.

Hearth & Home Technologies disclaims any responsibility for, and the warranty will be voided by, the following actions:

- Installation and use of any damaged appliance or vent system component.
- Modification of the appliance or vent system.
- Installation other than as instructed by Hearth & Home Technologies.
- Improper positioning of the gas logs or the glass door.
- Installation and/or use of any component part not approved by Hearth & Home Technologies.

Any such action may cause a fire hazard.

WARNING! Risk of Fire, Explosion or Electric Shock! DO NOT use this appliance if any part has been under water. Call a qualified service technician to inspect the appliance and to replace any part of the control system and/or gas control which has been under water.

D. Installation Methods: On-Wall or In-Wall

When installing the ION model, you may choose from one of two installation options.

1. On-Wall Installation:

The ION can hang on a sheet rock/combustible wall

2. In-Wall Installation:

The ION can be partially recessed into a wall using the In-Wall Tub Assembly

The On-Wall installation is the most common and least difficult method. On-Wall installation information is located in Sections 3, 6, and 10. In-Wall installation information is isolated in Section 11. Section 11 will discuss preparation, clearances and finishing specific to the In-Wall method. Consult the table of contents for topics common to both methods, such as vent configurations, gas and electrical information.

On-Wall Installation

The ION can hang on a sheet rock/combustible wall. See Sections 3, 6 and 10 for On-Wall installation information.

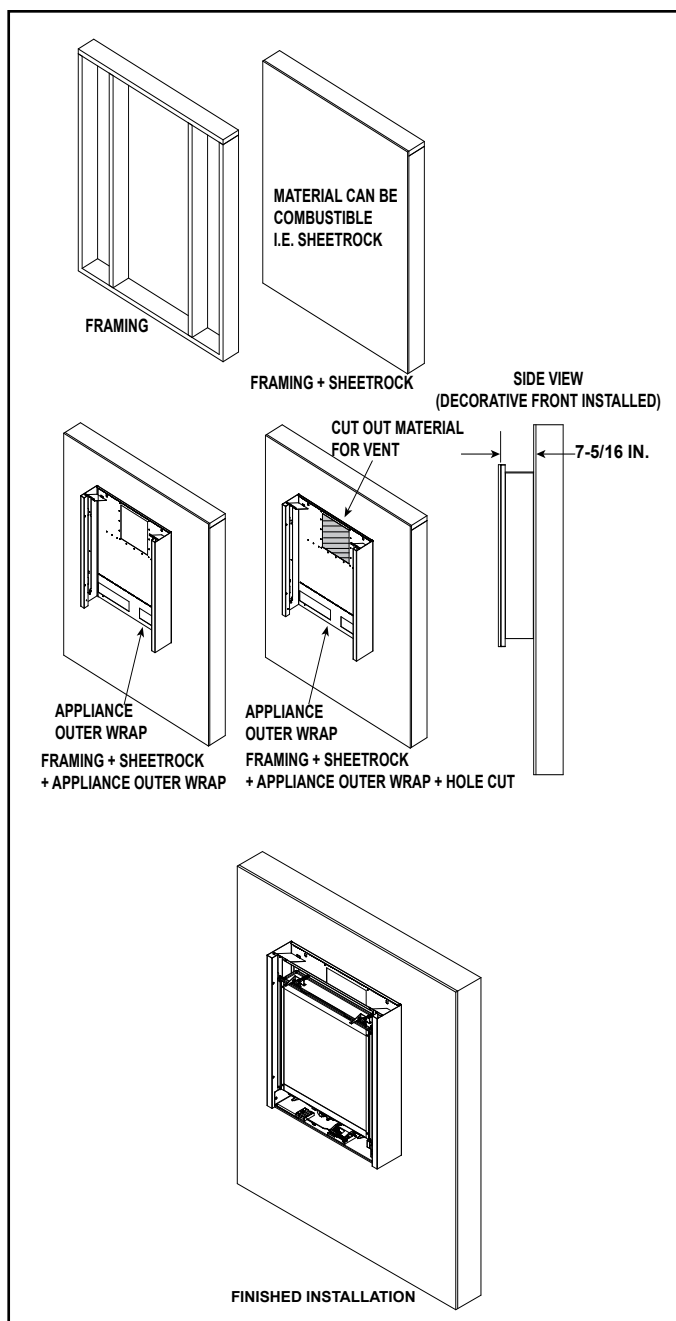

→ Figure 2.1 On-Wall Installation Method

In-Wall Installation

The ION can be partially recessed into a wall using the In-Wall Kit. See Service Parts section in Owner's Manual and contact your dealer to order. See Section 11 for installation information.

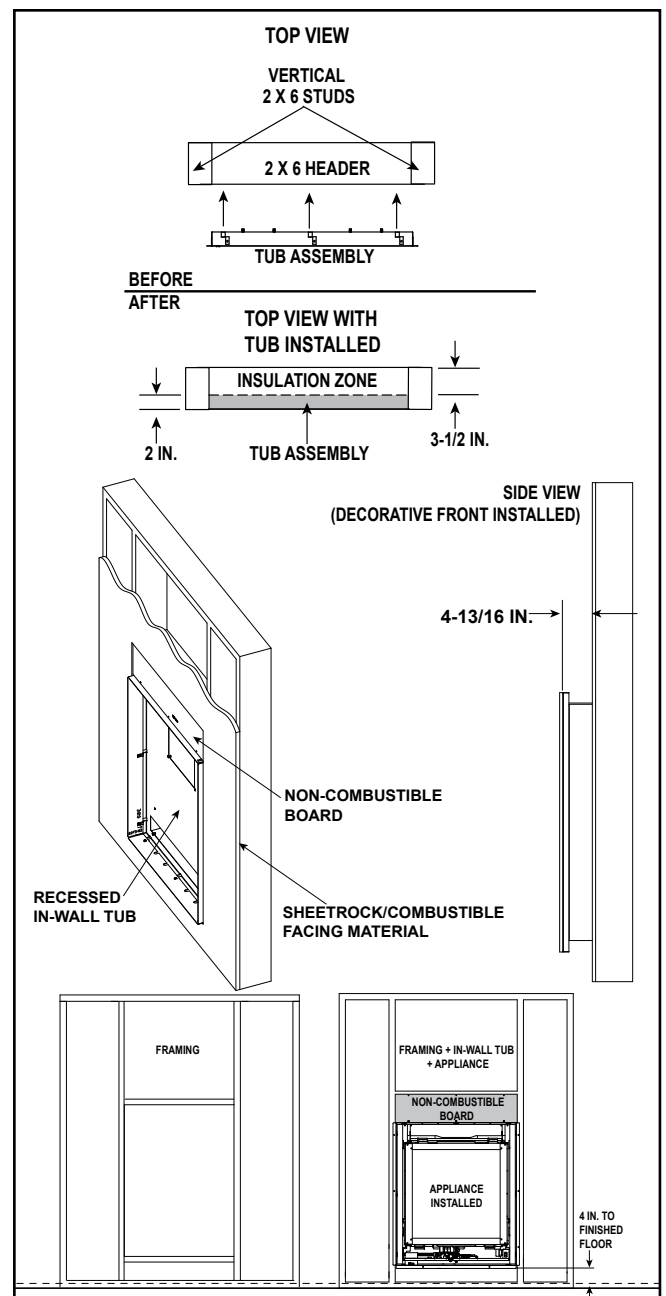

← Figure 2.2 In-Wall Installation Method

3 Framing and Clearances

A. Appliance/Decorative Front Dimension Diagrams

Dimensions are actual appliance dimensions. Use for reference only. For framing dimensions and clearances refer to Section 3 and Section 5.

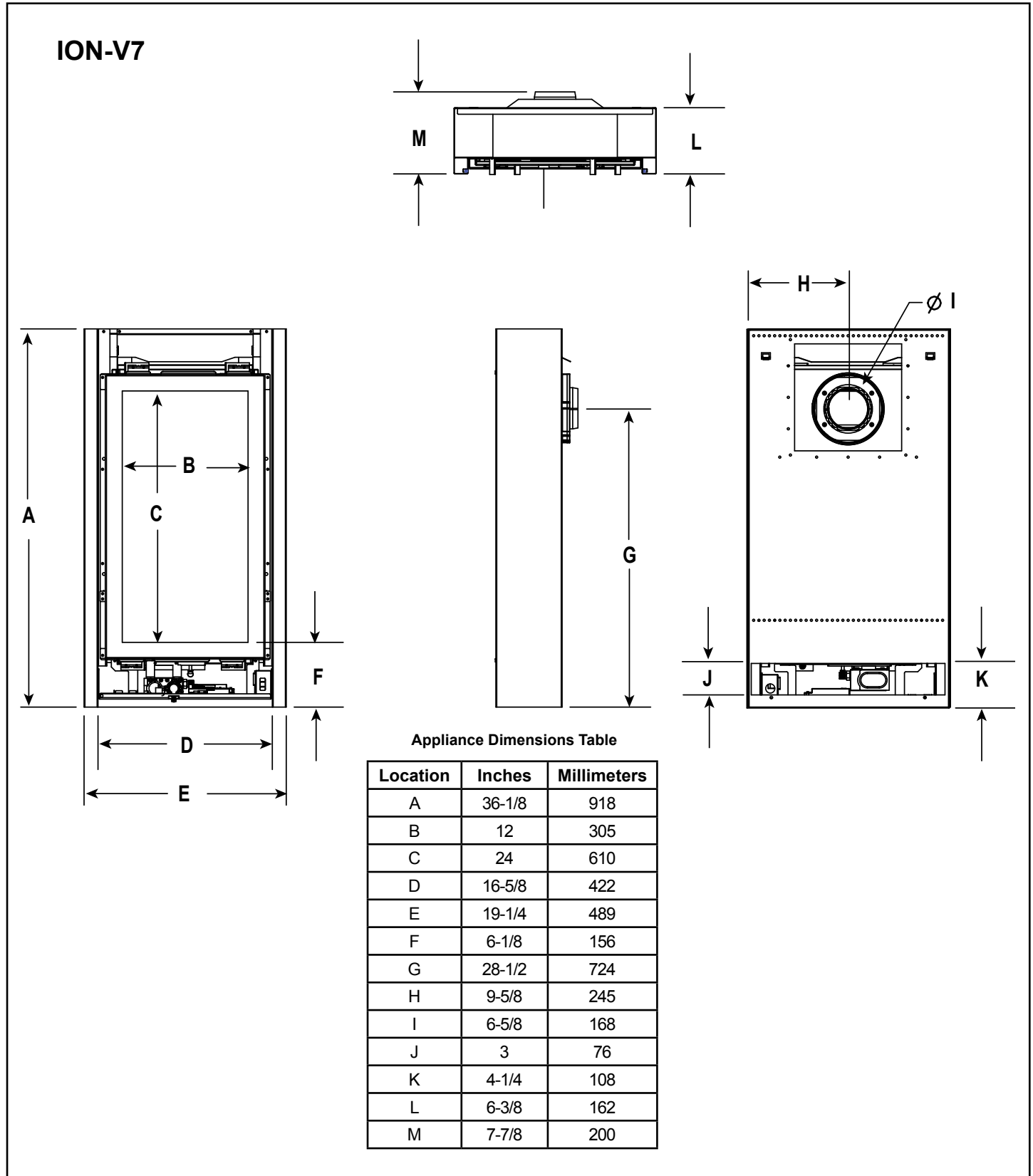
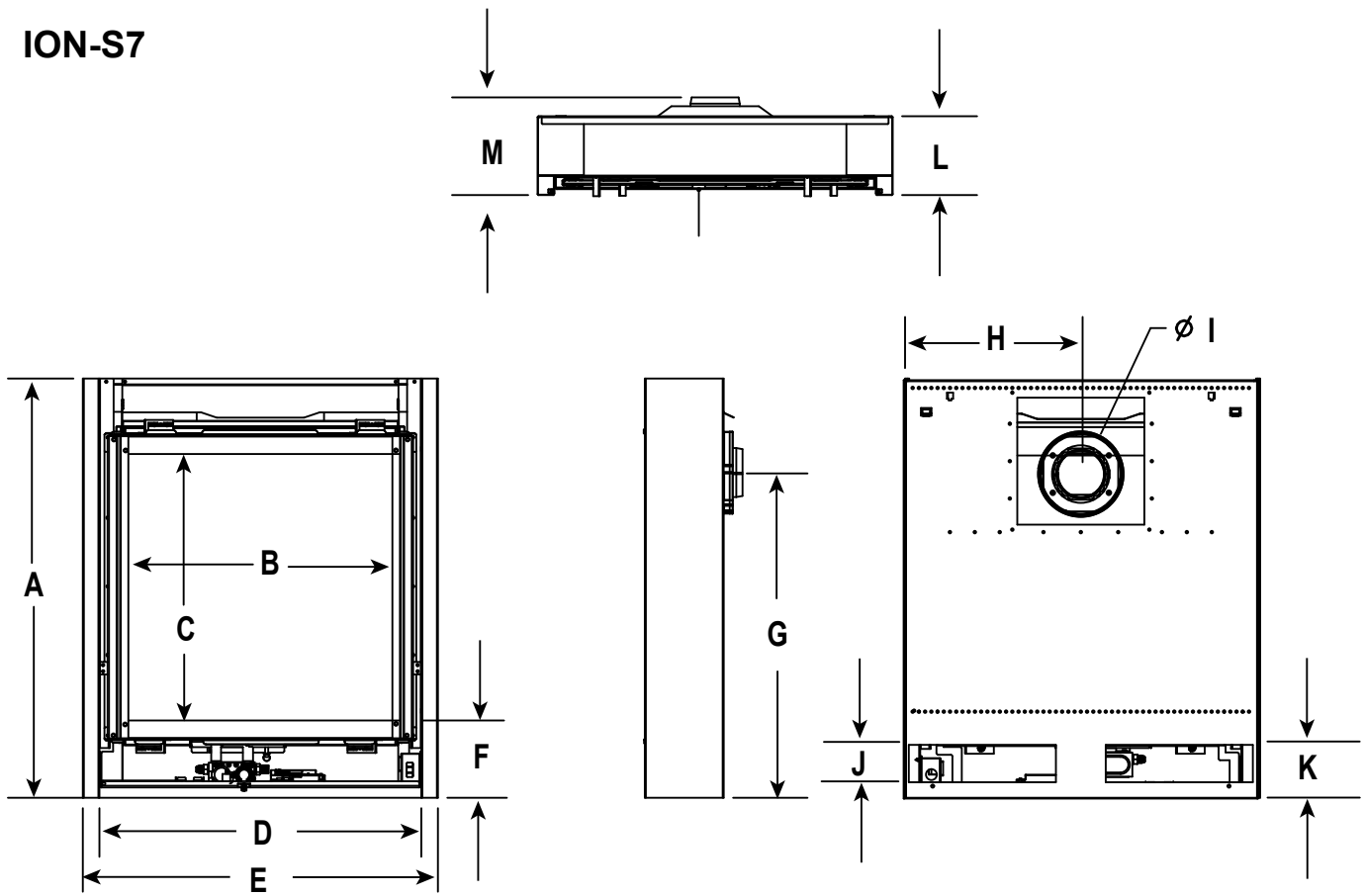

Figure 3.1 Appliance Dimensions - ION-V7

ION-S7



Appliance Dimensions Table

Location	Inches	Millimeters
A	33-5/8	854
B	21-1/8	537
C	21-3/8	543
D	25-3/4	654
E	28-1/2	724
F	6-1/4	159
G	26	660
H	14-1/4	362
I	6-5/8	168
J	3	76
K	4-5/16	109
L	6-3/8	162
M	7-7/8	200

Figure 3.2 Appliance Dimensions - ION-S7

ION-H7

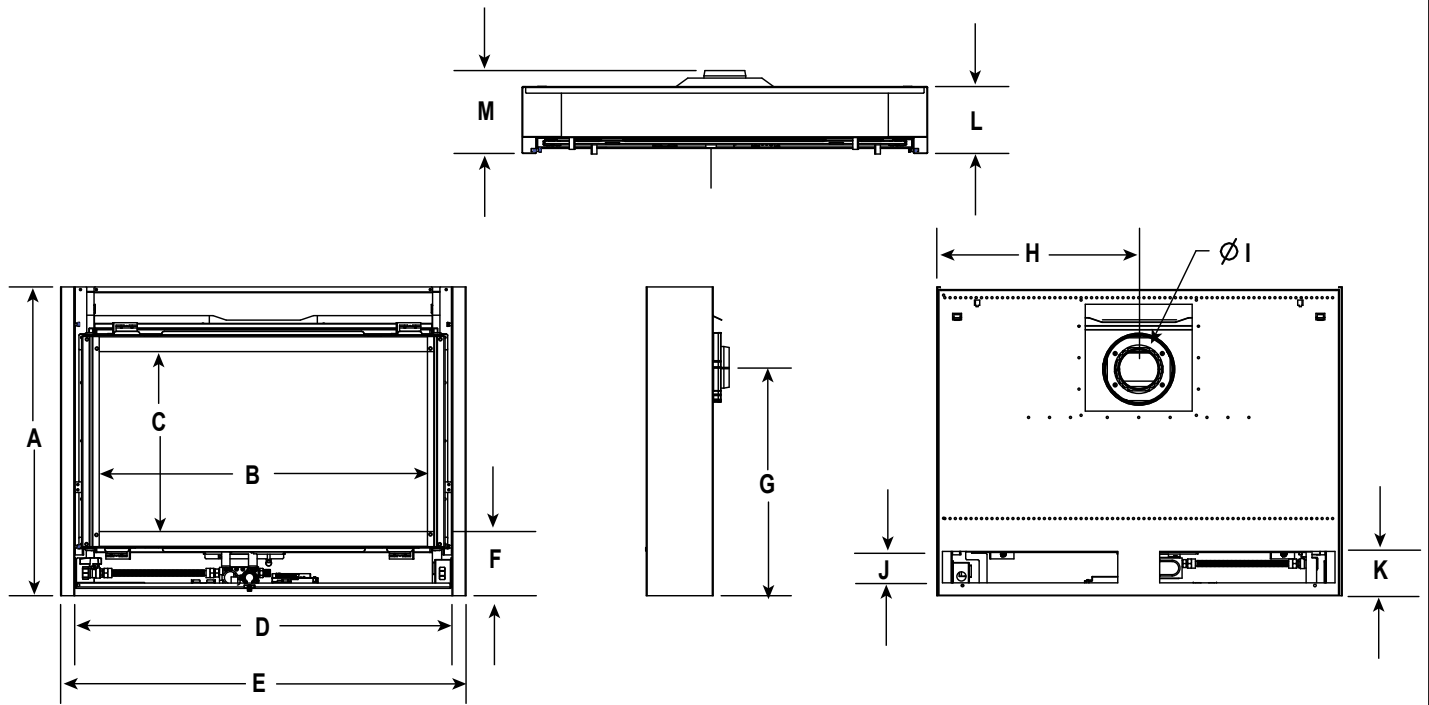

Appliance Dimensions Table

Location	Inches	Millimeters
A	29-1/8	740
B	31	787
C	17	432
D	35-5/8	905
E	38-1/4	972
F	6-1/8	156
G	21-1/2	546
H	19-1/8	486
I	6-5/8	168
J	3	76
K	4-3/16	106
L	6-3/8	162
M	7-7/8	200

Figure 3.3 Appliance Dimensions - ION-H7

FOUR SQUARE DECORATIVE FRONTS (DF-FSV7, DF-FSH7, DF-FSS7)

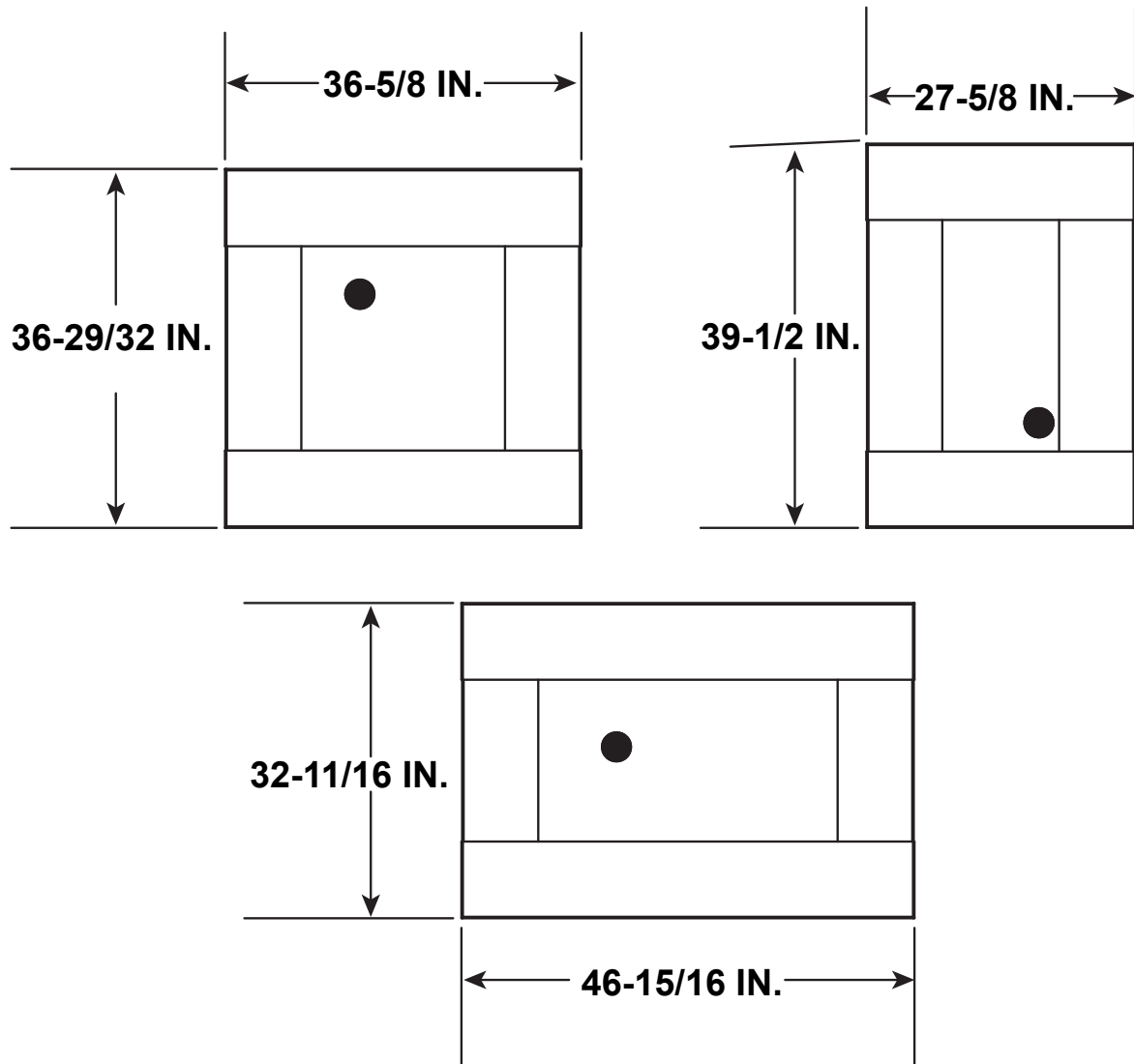

Figure 3.4 Appliance Dimensions - Four Square (DF-FSV7, DF-FSH7, DF-FSS7) Decorative Fronts

B. Clearance to Combustibles

When selecting a location for the appliance it is important to consider the required clearances to walls (see Figure 3.6).

WARNING! Risk of Fire or Burns! Provide adequate clearance around air openings and for service access. Due to high temperatures, the appliance should be located out of traffic and away from furniture and draperies.

NOTICE: Illustrations reflect typical installations and are FOR DESIGN PURPOSES ONLY. Illustrations/diagrams are not drawn to scale. Actual installation may vary due to individual design preference.

WARNING! Risk of Fire! Maintain specified air space clearances to appliance and vent pipe:

- Insulation and other materials must be secured to prevent accidental contact.
- The chase must be properly blocked to prevent blown insulation or other combustibles from entering and making contact with fireplace or chimney.
- Failure to maintain airspace may cause overheating and a fire.

See Figure 3.6, 3.7, 3.8, 3.9, and 3.11 for framing dimension requirements and required clearances.

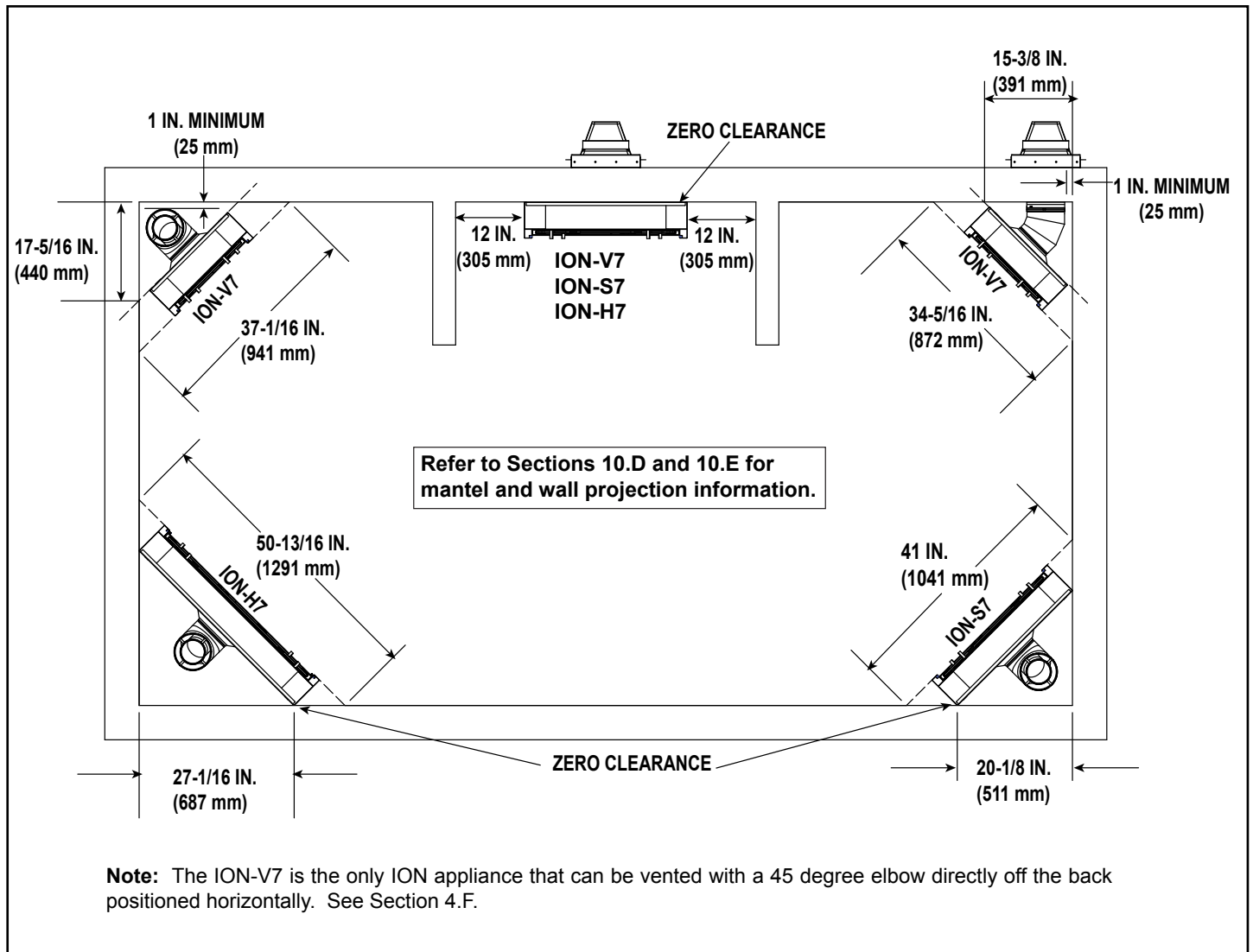

Figure 3.6 Appliance Locations

C. Constructing the Appliance Chase

A chase is a vertical box-like structure built to enclose the gas appliance and/or its vent system. In cooler climates the vent should be enclosed inside the chase.

NOTICE: *Treatment of ceiling firestops and wall shield firestops and construction of the chase may vary with the type of building. These instructions are not substitutes for the requirements of local building codes. Therefore, you MUST check local building codes to determine the requirements to these steps.*

To further prevent drafts, the wall shield and ceiling firestops should be caulked with caulk with a minimum of 300°F continuous exposure rating to seal gaps. Gas line holes and other openings should be caulked with caulk with a minimum of 300°F continuous exposure rating or stuffed with unfaced insulation. If the appliance is being installed on a cement surface, a layer of plywood may be placed underneath to prevent conducting cold up into the room.

D. Floor Protection

WARNING! Risk of overheating! *Install appliance a minimum of 4 inches off of finished floor.*

- *Convection air flow could be compromised and cause overheating.*
- *Decorative fronts will not fit properly.*
- *The finished floor below the appliance does not have to be non-combustible, due to the required 4 inch minimum clearance from bottom of appliance to finished floor.*

E. Clearances (On-Wall and In-Wall)

WARNING! Risk of overheating! Install appliance a minimum of 4 inches off of finished floor.

- Convection air flow could be compromised and cause overheating.
- Decorative fronts will not fit properly.

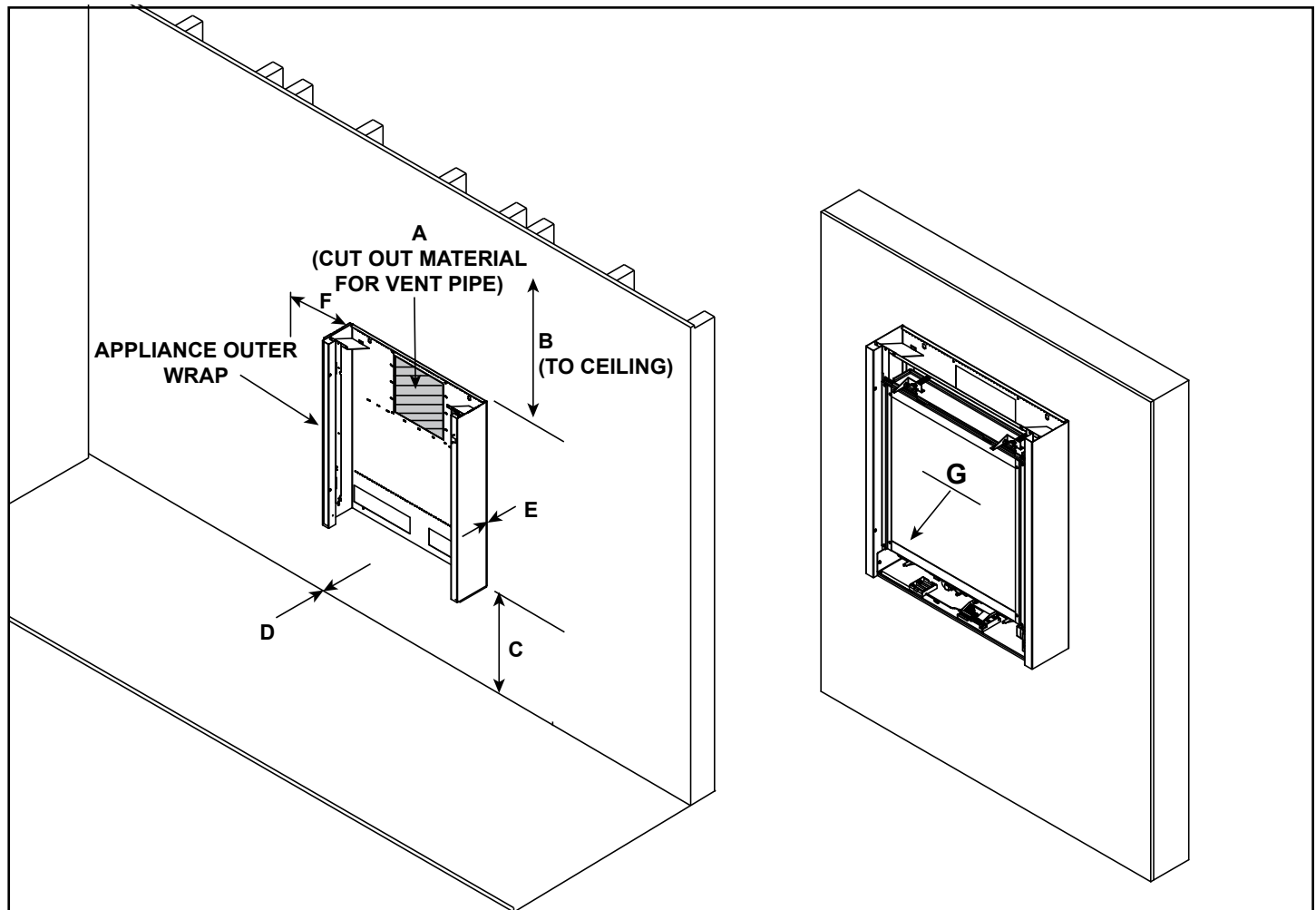

		MINIMUM CLEARANCES FROM APPLIANCE OUTER WRAP						
MODEL		A	B	C	D*	E**	F***	G
		Rough Opening (Vent Pipe)	Clearance to Ceiling	Minimum Clearance to Finished Floor	Clearance to Combustible Flooring	Behind Appliance Outer Wrap	Clearance to Adjacent Wall	Front of Appliance Measured from Mesh
ION-V7	in.	10-1/8	22	4	0	0	12	36
	mm	257	559	102	0	0	305	914
ION-S7	in.	10-1/8	22	4	0	0	12	36
	mm	257	559	102	0	0	305	914
ION-H7	in.	10-1/8	22	4	0	0	12	36
	mm	257	559	102	0	0	305	914

D* = Clearance to combustible floor not required due to 4 inch minimum on Dimension C.
 E** = The appliance outer wrap can attach directly to combustible material, i.e. sheetrock.
 F*** = See Section 10.D and 10.E for combustible and non-combustible mantel legs.

Figure 3.7

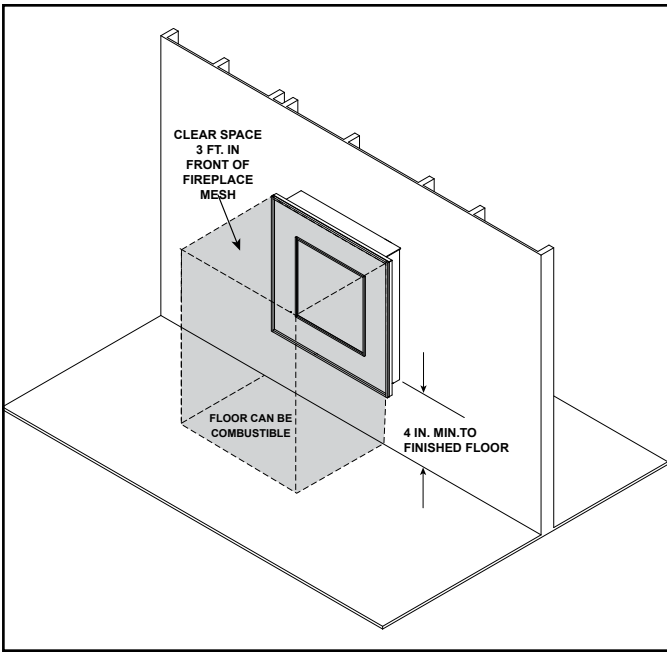
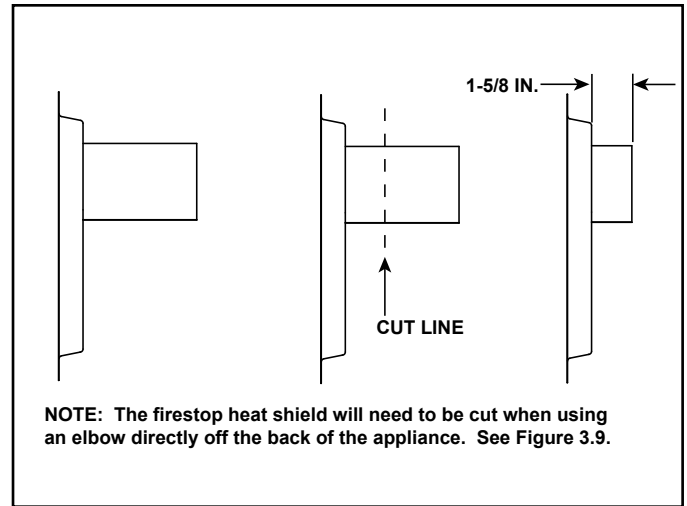

Figure 3.8 Clear Space Requirement - All Models



NOTE: The firestop heat shield will need to be cut when using an elbow directly off the back of the appliance. See Figure 3.9.

Figure 3.10 Wall Firestop Clearances

F. Clearances - Venting with an Elbow Directly Off the Back of Appliance

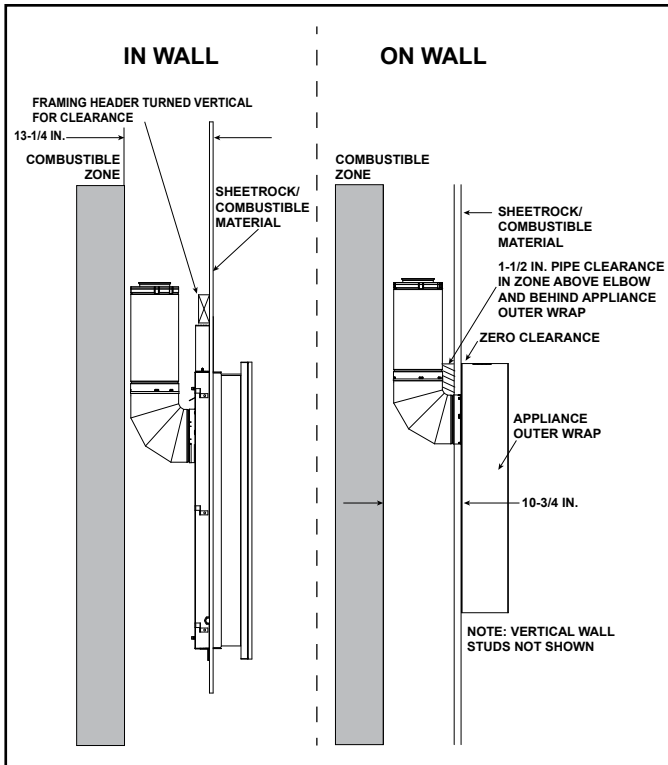

→ Figure 3.9 Clearance Requirements

Note: The firestop shield will need to be trimmed when venting with a 90 degree elbow directly off the back of the appliance. See Figure 3.10.

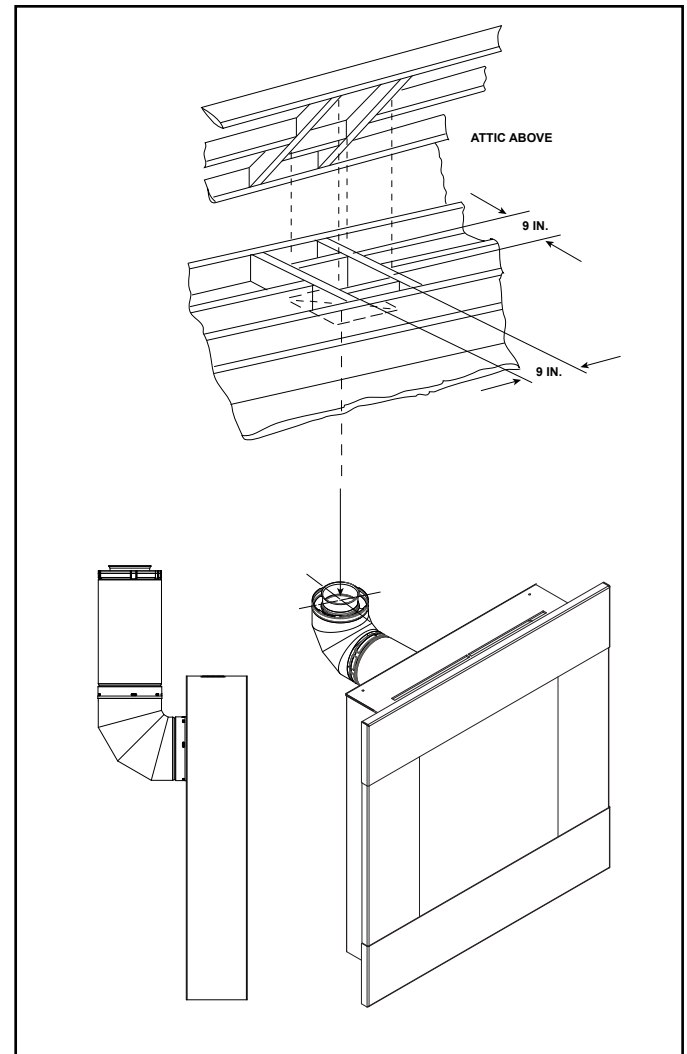

Figure 3.11 Ceiling Penetration Framing Requirements

See Section 5 for information regarding ceiling firestop.

4 Termination Location and Vent Information

A. Vent Termination Minimum Clearances

WARNING

Fire Risk.
Maintain vent clearance to combustibles as specified.

- **DO NOT** pack air space with insulation or other materials.

Failure to keep insulation or other materials away from vent pipe could cause overheating and fire.

Roof Pitch	H (Min.) Ft.
Flat to 6/12.....	1.0*
Over 6/12 to 7/12.....	1.25*
Over 7/12 to 8/12.....	1.5*
Over 8/12 to 9/12.....	2.0*
Over 9/12 to 10/12.....	2.5*
Over 10/12 to 11/12.....	3.25
Over 11/12 to 12/12.....	4.0
Over 12/12 to 14/12.....	5.0
Over 14/12 to 16/12.....	6.0
Over 16/12 to 18/12.....	7.0
Over 18/12 to 20/12.....	7.5
Over 20/12 to 21/12.....	8.0

* 3 foot minimum in snow regions

A	B
6 in. (minimum) up to 20 in. <i>152 mm/508 mm</i>	18 in. minimum <i>457 mm</i>
20 in. and over	0 in. minimum

* If using decorative cap cover(s), this distance may need to be increased. Refer to the installation instructions supplied with the decorative cap cover.

** In a staggered installation with both gas and wood or fuel oil terminations, the wood or fuel oil termination cap must be higher than the gas termination cap.

Figure 4.2 Staggered Termination Caps

Figure 4.1 Minimum Height From Roof To Lowest Discharge Opening

B. Chimney Diagram

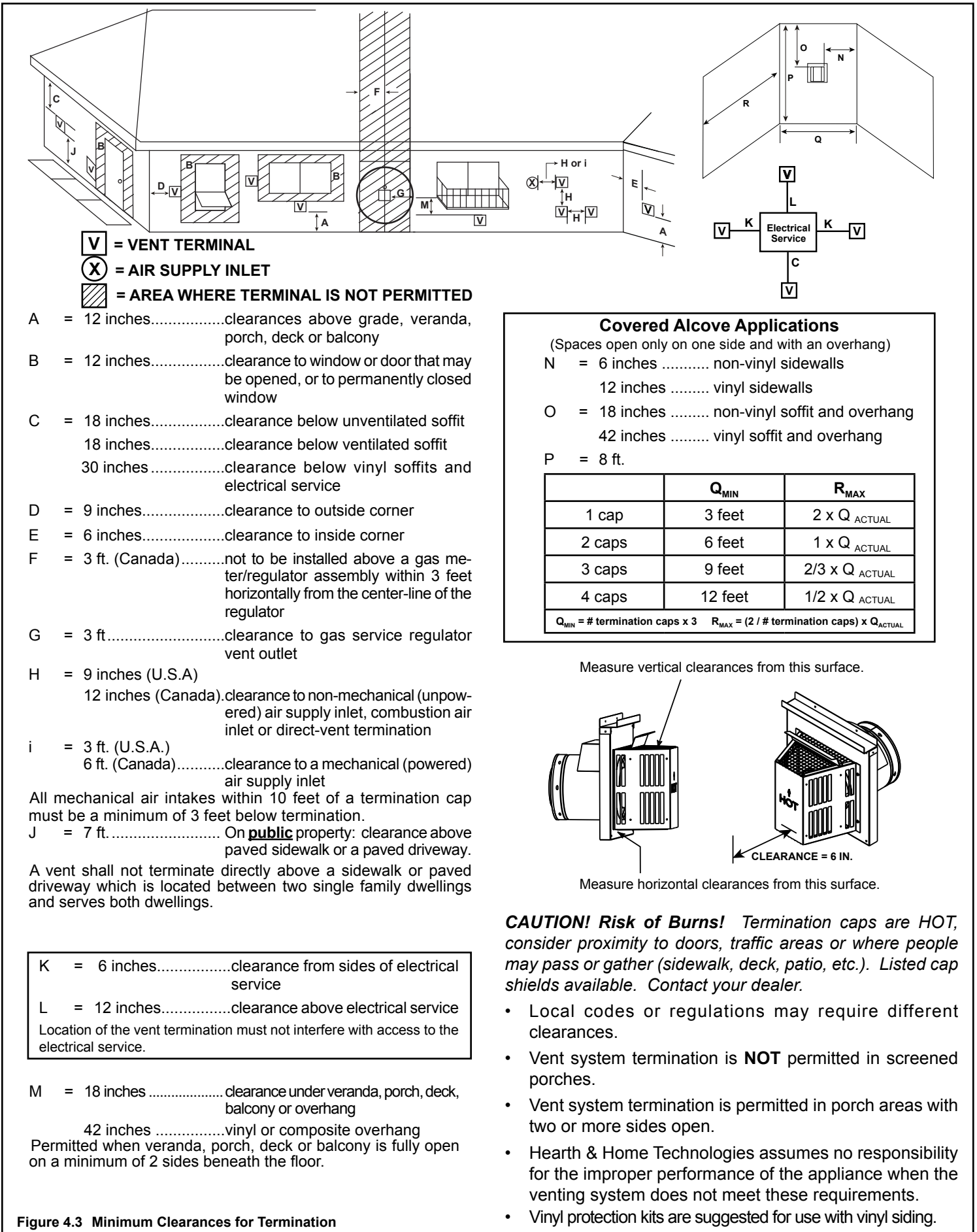

Figure 4.3 Minimum Clearances for Termination

C. Approved Pipe

This appliance is approved for use with Hearth & Home Technologies SLP venting systems. Refer to Section 13.A for vent component information and dimensions.

DO NOT mix pipe, fittings or joining methods from different manufacturers.

The pipe is tested to be run inside an enclosed wall. There is no requirement for inspection openings at each joint within the wall.

WARNING! Risk of Fire or Asphyxiation. This appliance requires a separate vent. **DO NOT** vent to a pipe serving a separate solid fuel burning appliance.

D. Use of Elbows

Diagonal runs have both vertical and horizontal vent aspects when calculating the effects. Use the rise for the vertical aspect and the run for the horizontal aspect. See Figure 4.4.

Two 45° elbows may be used in place of one 90° elbow. On 45° runs, one foot of diagonal is equal to 8-1/2 in. (216 mm) horizontal run and 8-1/2 in. (216 mm) vertical run. A length of straight pipe is allowed between two 45° elbows. See Figure 4.4.

Figure 4.5 shows the vertical and horizontal offsets for SLP elbows.

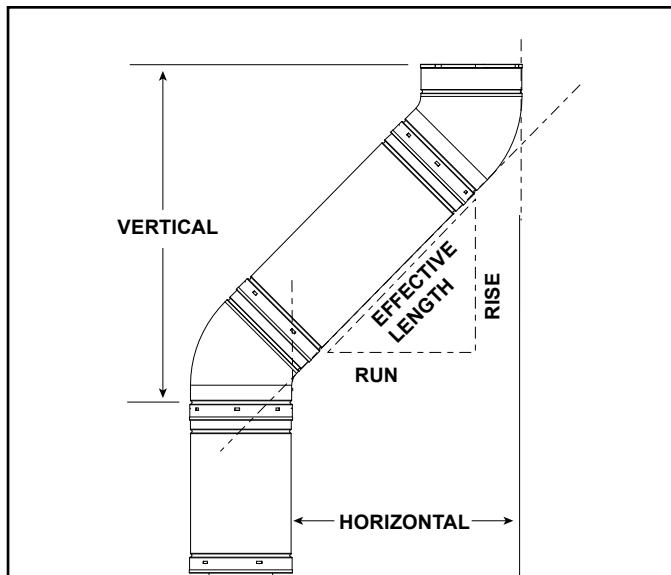

SLP Pipe	Effective Length		Rise/Run	
	Inches	Millimeters	Inches	Millimeters
SLP4	4	102	2-3/4	70
SLP6	6	152	4-1/4	108
SLP12	12	305	8-1/2	216
SLP24	24	610	17	432
SLP36	36	914	25-1/2	648
SLP48	48	1219	34	864
SLP6A	3 to 6	76 to 152	2-1/8-4-1/4	54-108
SLP12A	3 to 12	76 to 305	2-1/8-8-1/2	54-216

Figure 4.4

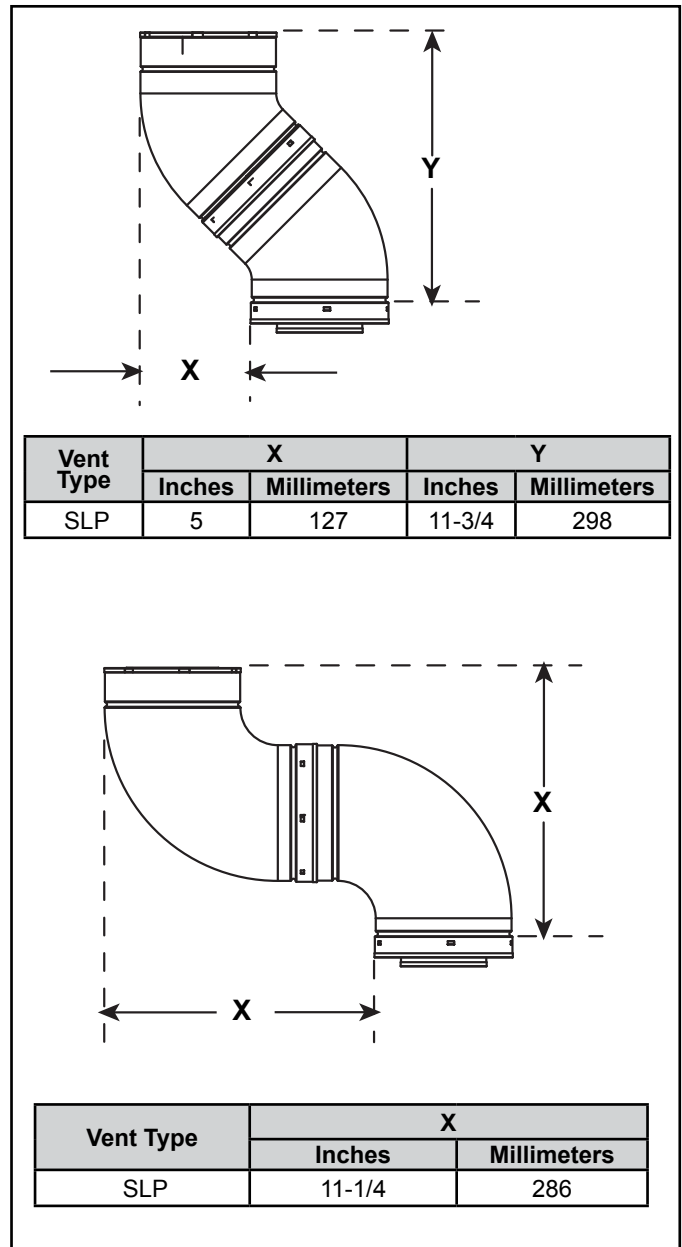

Figure 4.5 Vertical and Horizontal Offset for SLP Elbows

E. Measuring Standards

Vertical and horizontal measurements listed in the vent diagrams were made using the following standards.

- Pipe measurements are shown using the effective length of pipe. See Section 13.A for information on effective length of pipe components.
- Horizontal terminations are measured to the outside mounting surface (flange of termination cap) (see Figure 4.3).
- Vertical terminations are measured to bottom of termination cap.
- Horizontal pipe installed level with no rise.

F. Vent Diagrams

General Rules:

- 90° elbows can be replaced with two 45° elbows.
- SUBTRACT 3 ft. from the total H measurement for each 90° elbow installed horizontally.
- SUBTRACT 1-1/2 ft. from the total H measurement for each 45° elbow installed horizontally.
- A maximum of three 90° elbows (or six 45° elbows) may be used in any vent configuration. Some elbows may be installed horizontally. See Figure 4.9 and Figure 4.12 .
- When penetrating a combustible wall, a wall shield firestop must be installed. See Figure 5.1.
- When penetrating a combustible ceiling, a ceiling firestop must be installed. See Figure 5.4.
- Horizontal runs of vent do not require vertical rise; horizontal runs may be level.
- Horizontal termination cap should have a 1/4 inch downward slant to allow any moisture in cap to be released.

Horizontal Termination

No Elbow

H = 12 in. (305 mm) Maximum

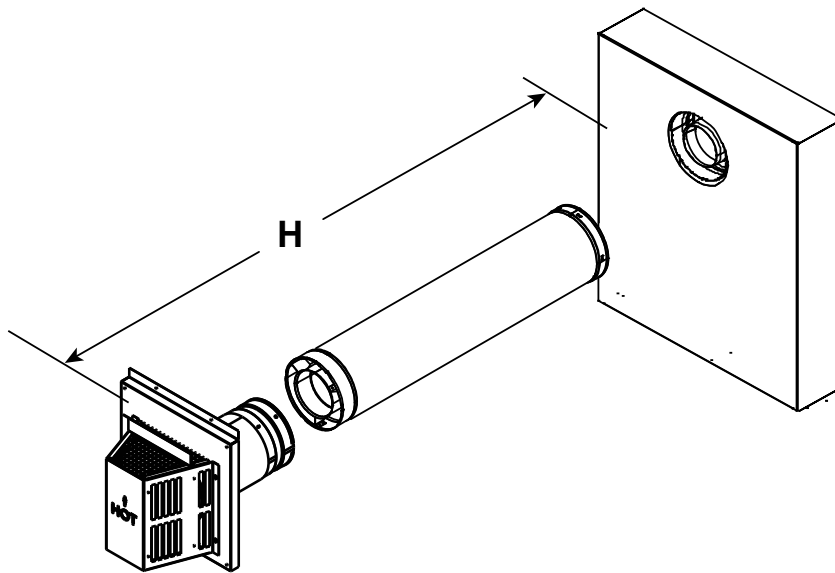
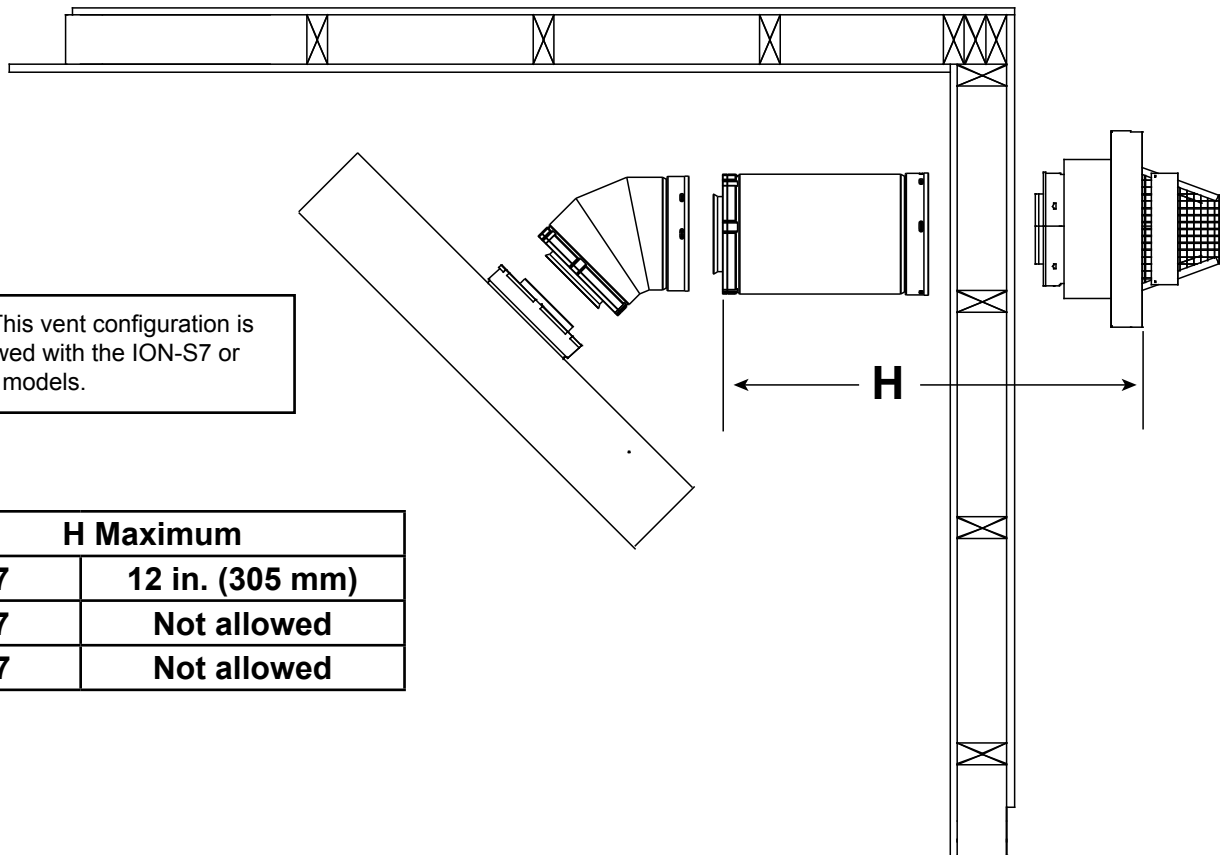

Figure 4.6

One 45° Elbow



Note: This vent configuration is not allowed with the ION-S7 or ION-H7 models.

H Maximum	
V7	12 in. (305 mm)
S7	Not allowed
H7	Not allowed

Figure 4.7

Horizontal Termination - (continued)

Two Elbows

V_1 Minimum		$H_1 + H_2$ Maximum	
Two 90° Elbows back to back		1 ft	305 mm
1 ft	305 mm	4 ft	1.2 m
2 ft	610 mm	7 ft	2.1 m
3 ft	914 mm	10 ft	3.0 m
4 ft	1.2 m	13 ft*	4.0 m*
5 ft	1.5 m	14 ft*	4.3 m*
6 ft	1.8 m	14 ft*	4.3 m*
7 ft	2.1 m	14 ft*	4.3 m*

$V_1 + H_1 + H_2 = 40$ ft. (12.2 m) Maximum
 H_{Total}^* : ION-S7 & ION-H7 = 14 ft. (4.3 m) Maximum
 : ION-V7 = 12 ft. (3.7 m) Maximum

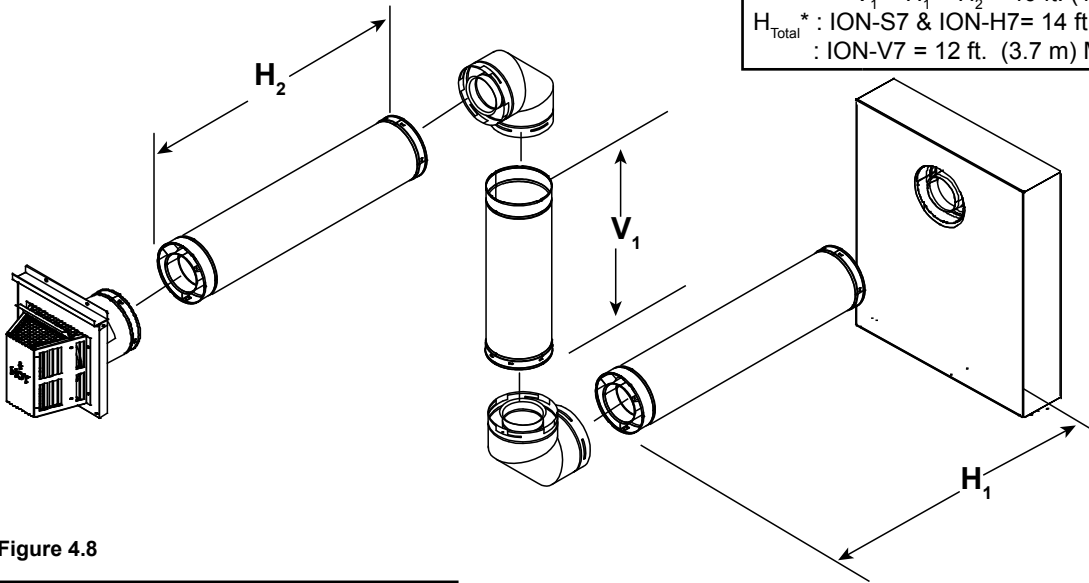

Figure 4.8

Three Elbows

V_1 Minimum		$H_1 + H_2 + H_3$ Maximum	
1 ft	305 mm	2 ft	610 mm
2 ft	610 mm	5 ft	1.5 m
3 ft	914 mm	8 ft	2.4 m
4 ft	1.2 m	11 ft	3.4 m
5 ft	1.5 m	14 ft*	4.3 m*
6 ft	1.8 m	14 ft*	4.3 m*
7 ft	2.1 m	14 ft*	4.3 m*

$V_1 + H_1 + H_2 + H_3 = 40$ ft. (12.2 m) Maximum
 $V_1 = 1$ ft (305 mm) Minimum
 H_{Total}^* : ION-S7 & ION-H7 = 14 ft. (4.3 m) Maximum
 : ION-V7 = 12 ft. (3.7 m) Maximum

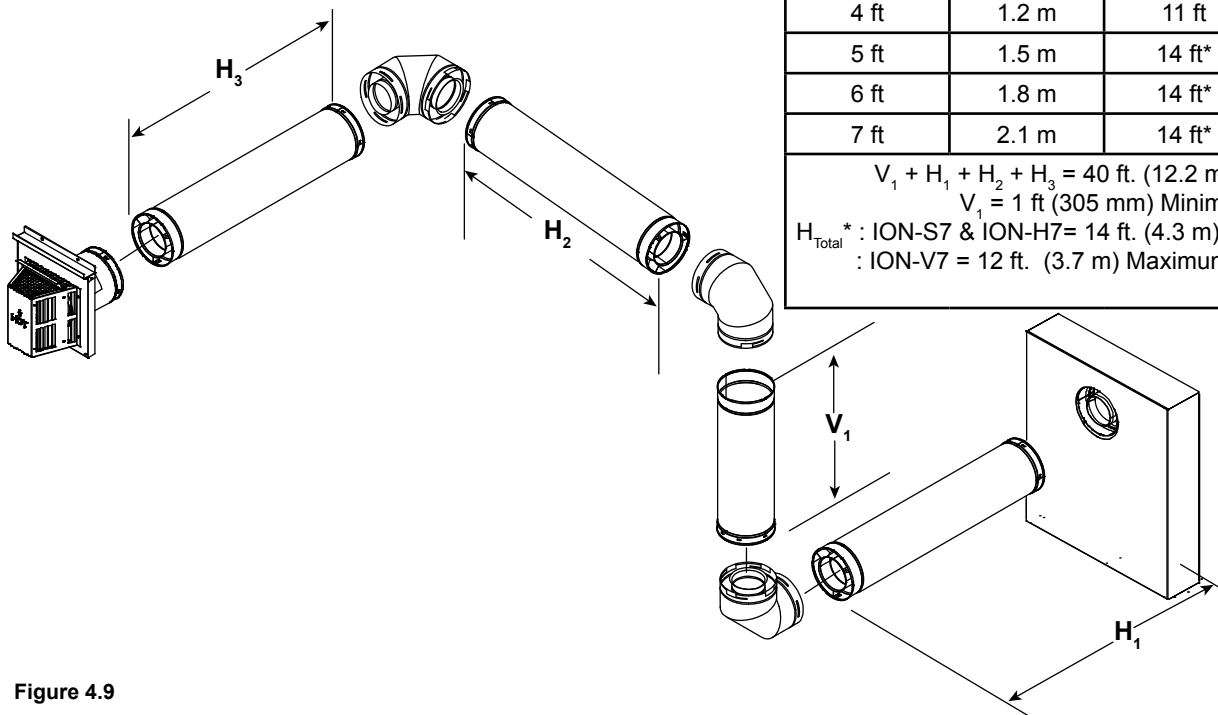
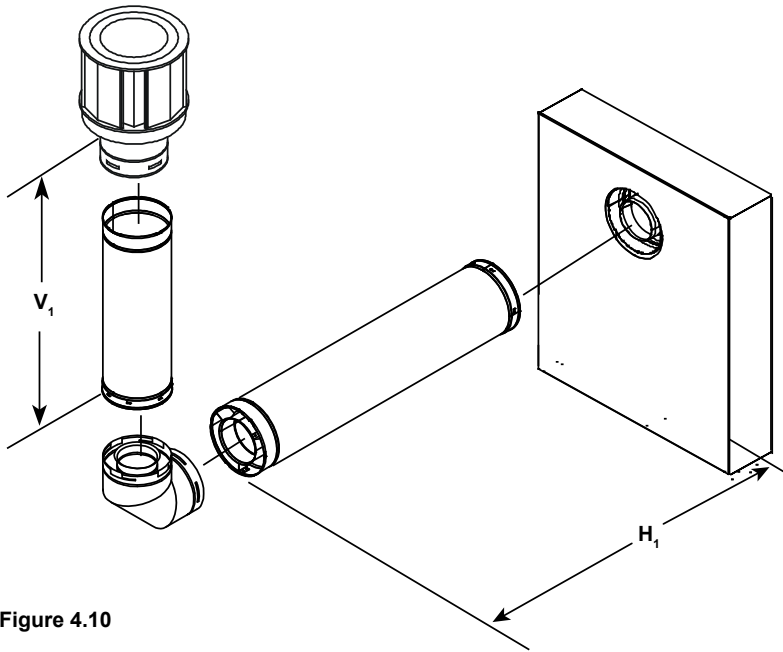

Figure 4.9

Vertical Termination

One Elbow



V_1 Minimum		H_1 Maximum	
2 ft	610 mm	5 ft	1.5 m
3 ft	914 mm	8 ft	2.4 m
4 ft	1.2 m	11 ft	3.4 m
5 ft	1.5 m	14 ft*	4.3 m*
6 ft	1.8 m	14 ft*	4.3 m*
7 ft	2.1 m	14 ft*	4.3 m*
$V_1 + H_1 = 40$ ft (12.2 m) Maximum $V_1 = 2$ ft (610 mm) Minimum H_{Total}^* : ION-S7 & ION-H7 = 14 ft. (4.3 m) Maximum : ION-V7 = 12 ft. (3.7 m) Maximum			

Figure 4.10

Two Elbows

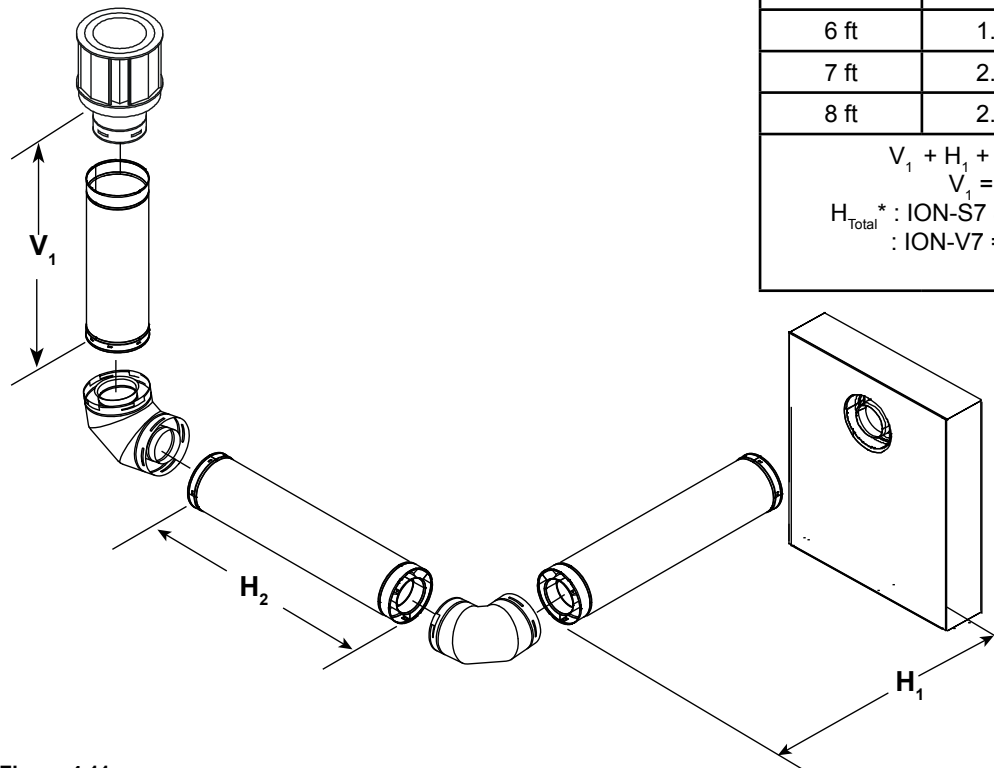

V_1 Minimum		$H_1 + H_2$ Maximum	
2 ft	610 mm	4 ft	1.2 m
3 ft	914 mm	7 ft	2.1 m
4 ft	1.2 m	10 ft	3.0 m
5 ft	1.5 m	13 ft*	4.0 m*
6 ft	1.8 m	14 ft*	4.3 m*
7 ft	2.1 m	14 ft*	4.3 m*
8 ft	2.4 m	14 ft*	4.3 m*
$V_1 + H_1 + H_2 = 40$ ft (12.2 m) Maximum $V_1 = 2$ ft (610 mm) Minimum H_{Total}^* : ION-S7 & ION-H7 = 14 ft. (4.3 m) Maximum : ION-V7 = 12 ft. (3.7 m) Maximum			

Figure 4.11

Vertical Termination - (continued)

Three Elbows

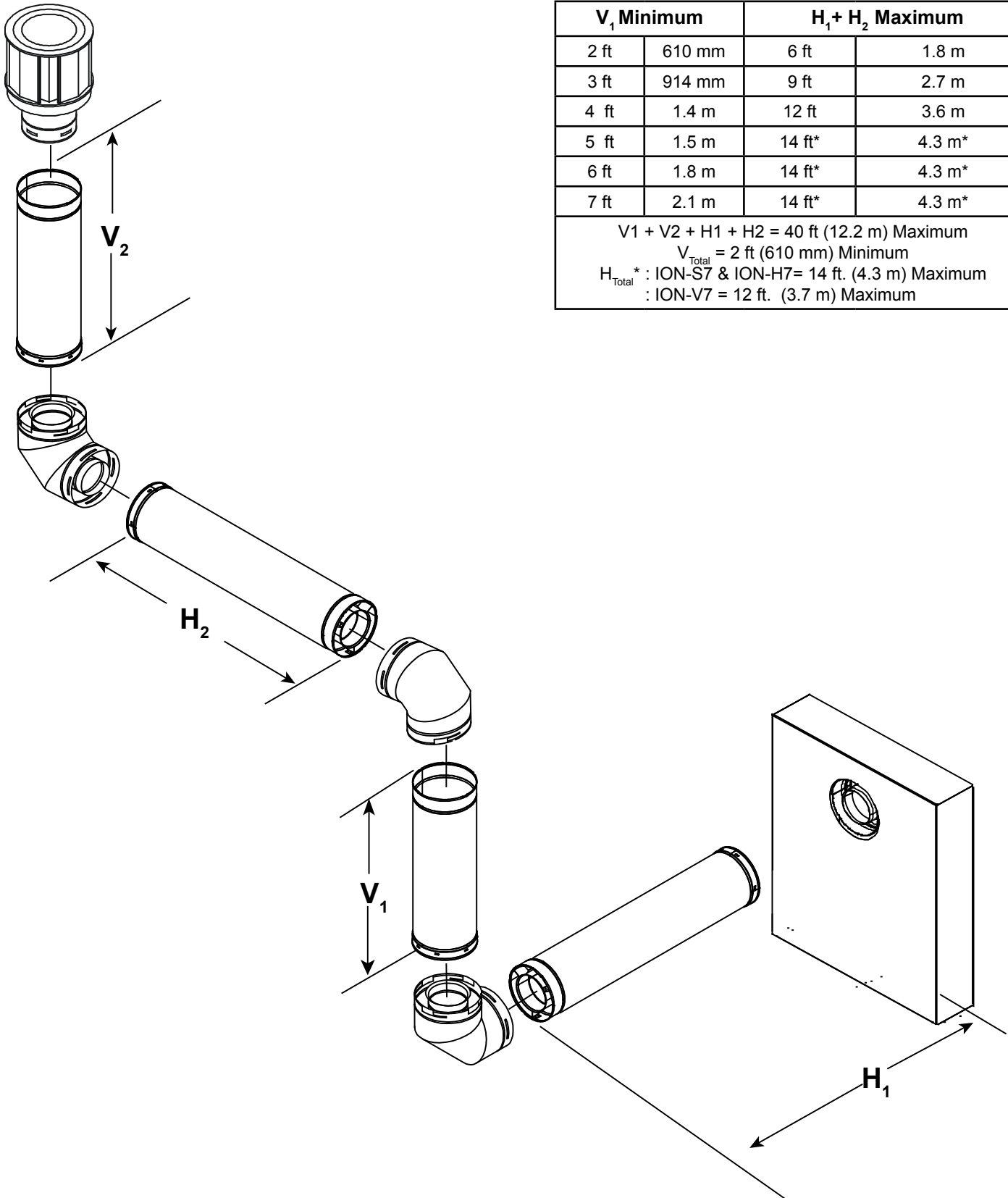

Figure 4.12

Vertical Termination - (continued)

One Elbow

Note: If the vertical component of the vent configuration is 10 feet or greater, the baffle may need to be adjusted as noted in this section. The air shutter may also need adjustment. See Section 9.E.

V1 Maximum = 40 ft (12.2 m)

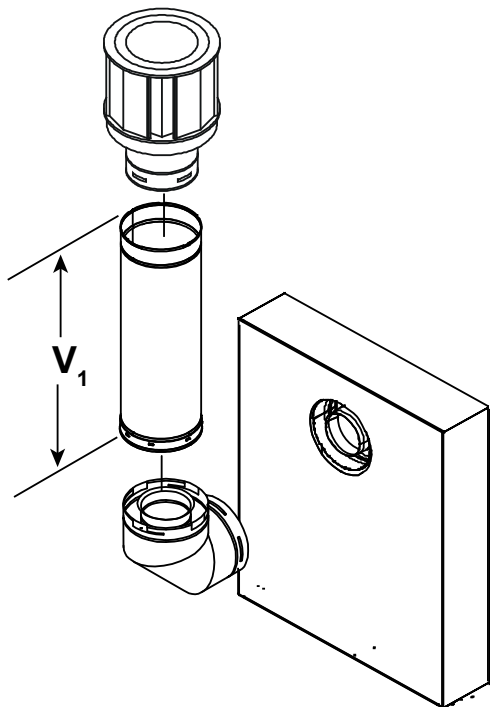

Figure 4.13 Vertical Venting With One Elbow

Vent Configurations with Vertical Components in Excess of 10 Feet

The ION model is shipped with an adjustable baffle shipped in the full open position. See Figure 4.15. The baffle may need to be adjusted if the vertical component of the vent configuration is 10 feet or greater. See the chart in Figure 4.14 to determine the correct setting for the application being installed. Closing the air shutter and baffle will improve the flame height if the vent configuration involves a significant amount of vertical venting. If the baffle is closed too far, pilot starvation and/or sooting may occur. Ensure the baffle screw(s) is/are secure once the adjustment is made.

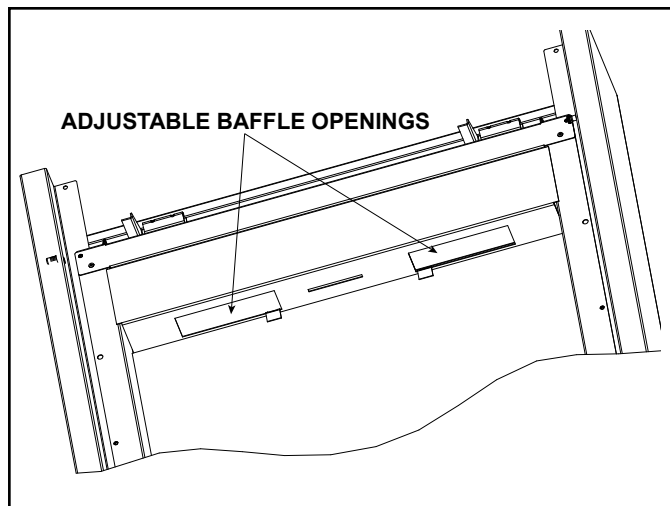
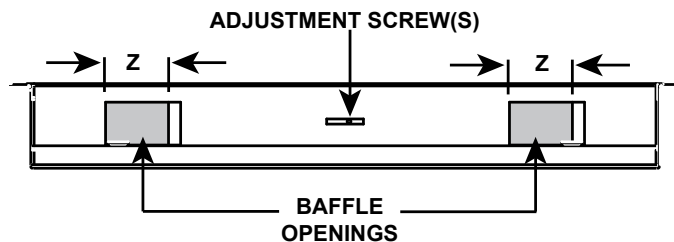

Figure 4.15 Adjustable Baffle Location

VERTICAL DIMENSION	BAFFLE SETTING Z Dimension (Below)			
	V7(NG/LP)	S7 (NG/LP)	H7 (NG)	H7 (LP)
10-20 ft.	1-1/4 in.	2-1/4 in.	2-1/4 in.	1-3/4 in.
21-30 ft.	1-1/8 in.	2-1/8 in.	2-1/8 in.	1-5/8 in.
30 ft. or more	1 in.	2 in.	2 in.	1-1/2 in.



Note: The ION-H7 will have two adjustment screws and a fixed center baffle opening.

Figure 4.14 Baffle Settings

Coaxial to Colinear Venting

The coaxial to colinear adapter (DV-46DVA-GCL) is approved for installations into solid fuel masonry or factory built fireplaces that have been installed in accordance with the National, Provincial, State and local building codes. The DV-46DVA-GCL must be recessed into existing masonry fireplace. See Table 1 and Figure 4.16.

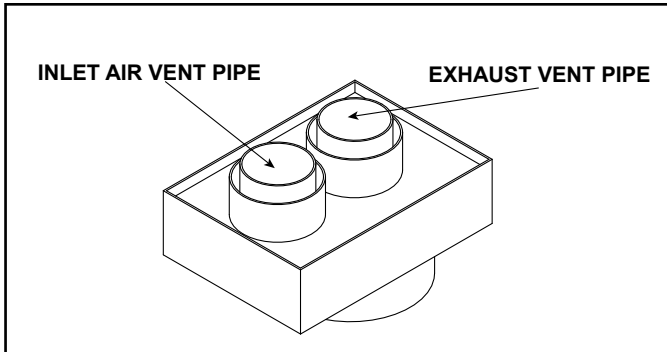

Figure 4.16. Coaxial/Colinear Appliance Connector

WARNING! Risk of Fire! Coaxial to colinear venting configuration may only be used in existing non-combustible chimney. Installation in any other venting application could cause fire.

Prior to installing the gas appliance:

- Have the chimney and adjacent structure inspected and cleaned by qualified professionals. Hearth & Home Technologies recommends that NFI or CSIA certified professionals, or technicians under the direction of certified professionals, conduct a minimum of a NFPA 211 Level 2 inspection of the chimney.
- Replace component parts of the chimney and fireplace as specified by the professionals.
- Ensure all joints are properly engaged and the chimney is properly secured.

Table 1

CLEARANCE TO COMBUSTIBLES REQUIREMENTS	
DV-46DVA-GCL	3 IN.
Exhaust Vent Pipe	5 IN.

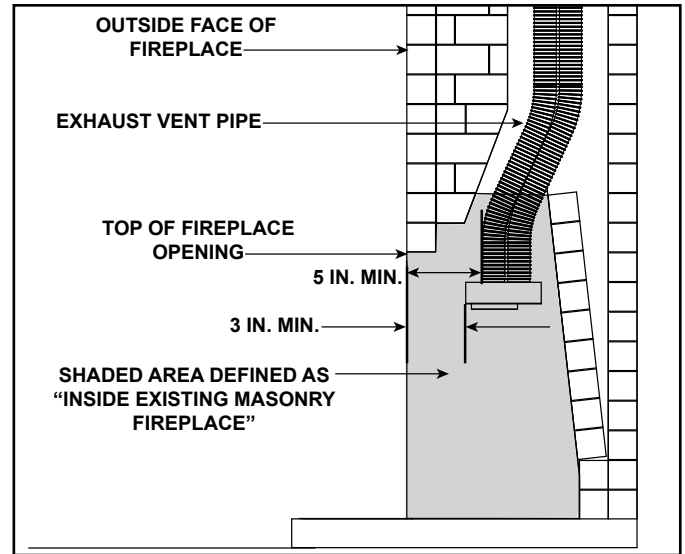

Figure 4.17. Existing Fireplace DV-46DVA-GCL Clearance Requirements

Clearances to Combustibles:

Refer to Section 10 and Section 11 for clearances to the appliance, mantel, mantel legs and wall projection.

Refer to Section 5 for pipe clearances to combustibles.

Termination Cap

For installation of termination cap see minimum vent heights for various pitched roofs. See Section 4.

Flue Baffle

Fully lock the fireplace's flue baffle in the open position, OR completely remove it. See Figure 4.14.

Venting Components

The LINK-DV30B is approved for use with the coaxial/colinear venting application. The LINK-DV30B kit includes:

- Two 30 feet sections of flexible vent pipe (3 inches Ø). One section is used to draw combustion air and the other section is used to expel exhaust gases.
- One vertical termination cap.

CAUTION! DO NOT use any flue restrictor when venting with the DV-46DVA-GCL adapter and LINK-DV30B kit. This may result in poor flame appearance, sooting, pilot malfunction, or overheating.

Connecting the DV-46DVA-GCL Adapter to Appliance

Rear Vent

- Connect the vertically positioned elbow. Secure DV-46DVA-GCL adapter to the elbow with 3-1/2 in. self-tapping screws. See Figure 4.18.

Connecting the LINK-DV30B to the DV-46DVA-GCL adapter

- Insert the two sections of flexible vent pipe down the existing chimney.
- Attach one section of stainless steel flex pipe to the exhaust collar on top of the DV-46DVA-GCL adapter with three screws.
- Attach one section of flexible vent pipe to the stainless steel flex pipe with three self-tapping screws.
- Attach one section of flexible vent pipe to the inlet collar on top of the DV-46DVA-GCL adapter with three self-tapping screws.
- To minimize cold air drafts, seal around the flex vents at the damper inside the chimney with non-combustible

unfaced fiberglass or rock wool insulation.

The DV-46DVA-GCL adapter must be recessed into existing masonry fireplace. This measurement is taken from the top of the fireplace opening. See Table 1 and Figure 4.17.

WARNING! Risk of Fire, Explosion or Asphyxiation!
Do NOT connect this gas appliance to a chimney flue serving a separate solid fuel or gas burning appliance.

- May impair safe operation of this appliance or other appliances connected to the flue.
- Vent this appliance directly outside.
- Use separate vent system for this appliance.

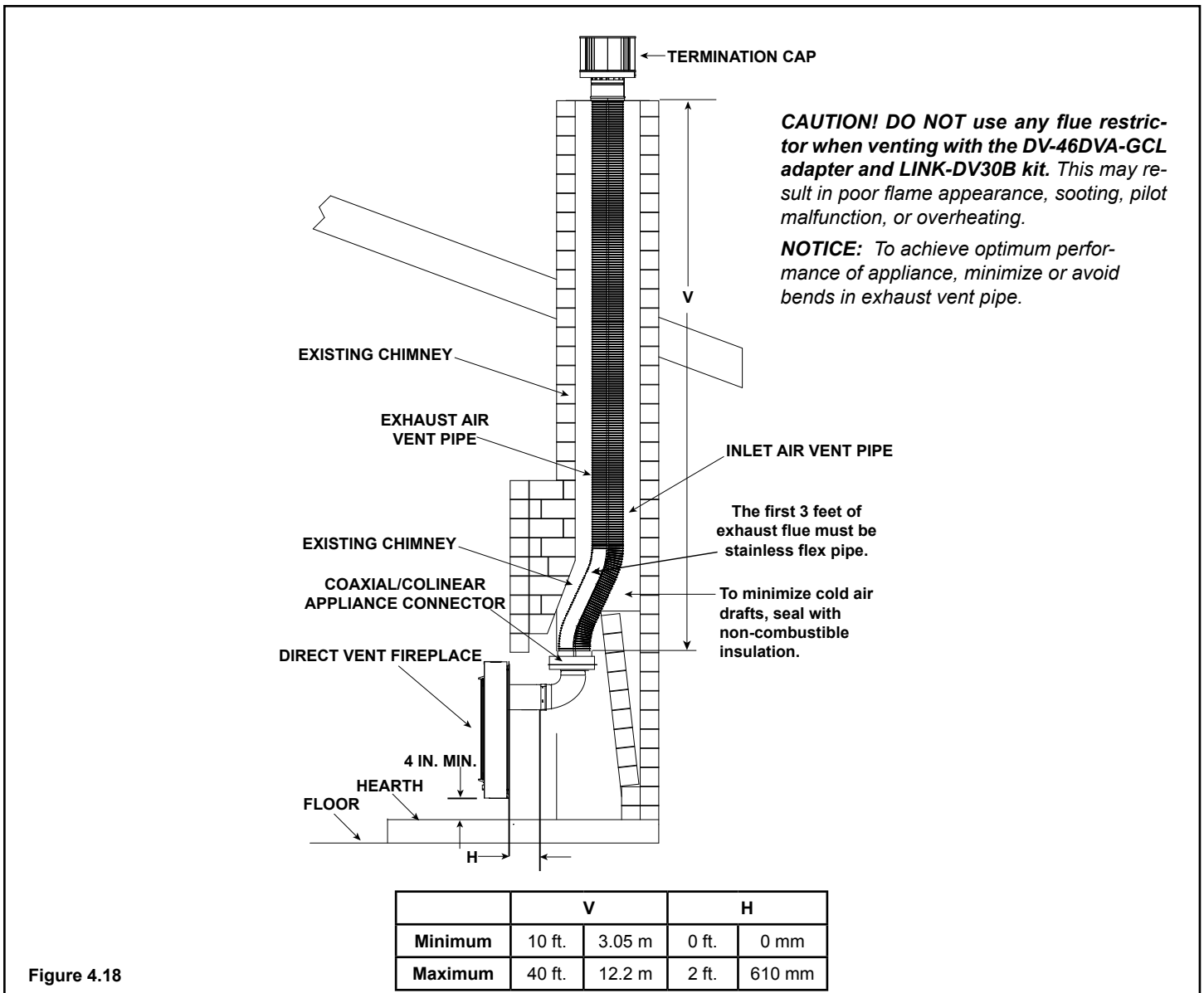

Figure 4.18

5 Vent Clearances and Framing

A. Pipe Clearances to Combustibles

WARNING! Risk of Fire! Maintain air space clearance to vent. DO NOT pack insulation or other combustibles:

- Between ceiling firestops
- Between wall shield firestops
- Around vent system

Failure to keep insulation or other material away from vent pipe could cause overheating and fire.

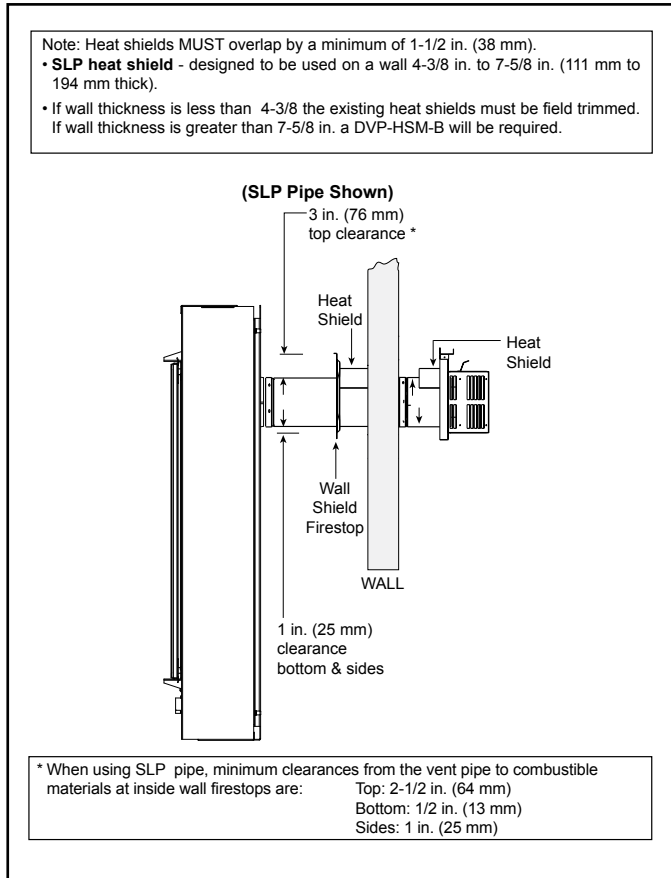

Figure 5.1 Horizontal Venting Clearances To Combustible Materials

Note: Vertical venting requires 1 inch clearance on all sides of the pipe.

B. Wall Penetration Framing/Firestops

Combustible Wall Penetration

Whenever a combustible wall is penetrated, you must frame a hole for the wall shield firestop(s). The wall shield firestop maintains minimum clearances and prevents cold air infiltration.

- The opening must be framed on all four sides using the same size framing materials as those used in the wall construction.

- SLP pipe - A wall shield firestop must be placed on each side of an interior wall. A minimum 1-1/2 in. (38 mm) overlap of attached heat shields must be maintained.
- See Section 7.F. for information for regarding the installation of a horizontal termination cap.

Non-Combustible Wall Penetration

If the hole being penetrated is surrounded by non-combustible materials such as concrete, a hole with diameter one inch greater than the pipe is acceptable.

Whenever a non-combustible wall is penetrated, the wall shield firestop is only required on one side and no heat shield is necessary.

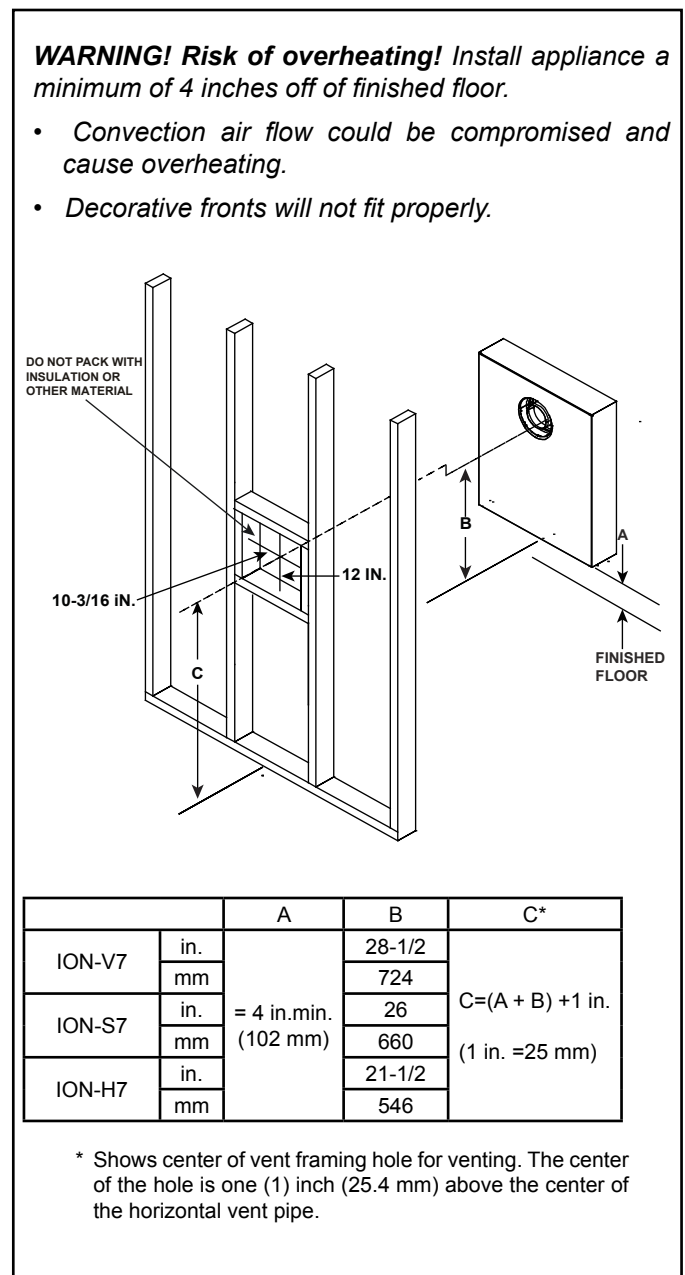

Figure 5.2 Wall Penetration

C. Ceiling Firestop/Floor Penetration Framing

A ceiling firestop **MUST** be used between floors and attics.

- Frame opening 9 in. x 9 in. (229 mm x 229 mm) whenever the vent penetrates a ceiling/floor. See Figure 5.3.
- Frame the area with the same sized lumber as used in ceiling/floor joist.
- The ceiling firestop may be installed above or below the ceiling joists when installed with a attic insulation shield. It must be under joists between floors that are not insulated. Refer to Figure 5.4.
- Secure with three fasteners on each side.

WARNING! Risk of Fire! DO NOT pack insulation around the vent. Insulation must be kept back from the pipe to prevent overheating.

D. Install Attic Insulation Shield

WARNING! Fire Risk. DO NOT allow loose materials or insulation to touch vent. Hearth & Home Technologies requires the use of an attic shield.

The International Fuel Gas Code requires an attic shield constructed of 26 gauge minimum steel that extends at least 2 in. (51 mm) above insulation.

- Attic insulation shields must meet specified clearances to combustible materials and be secured in place.
- An attic insulation shield kit is available from Hearth & Home Technologies. Contact your dealer to order. Install attic insulation shield according to instructions included with kit.

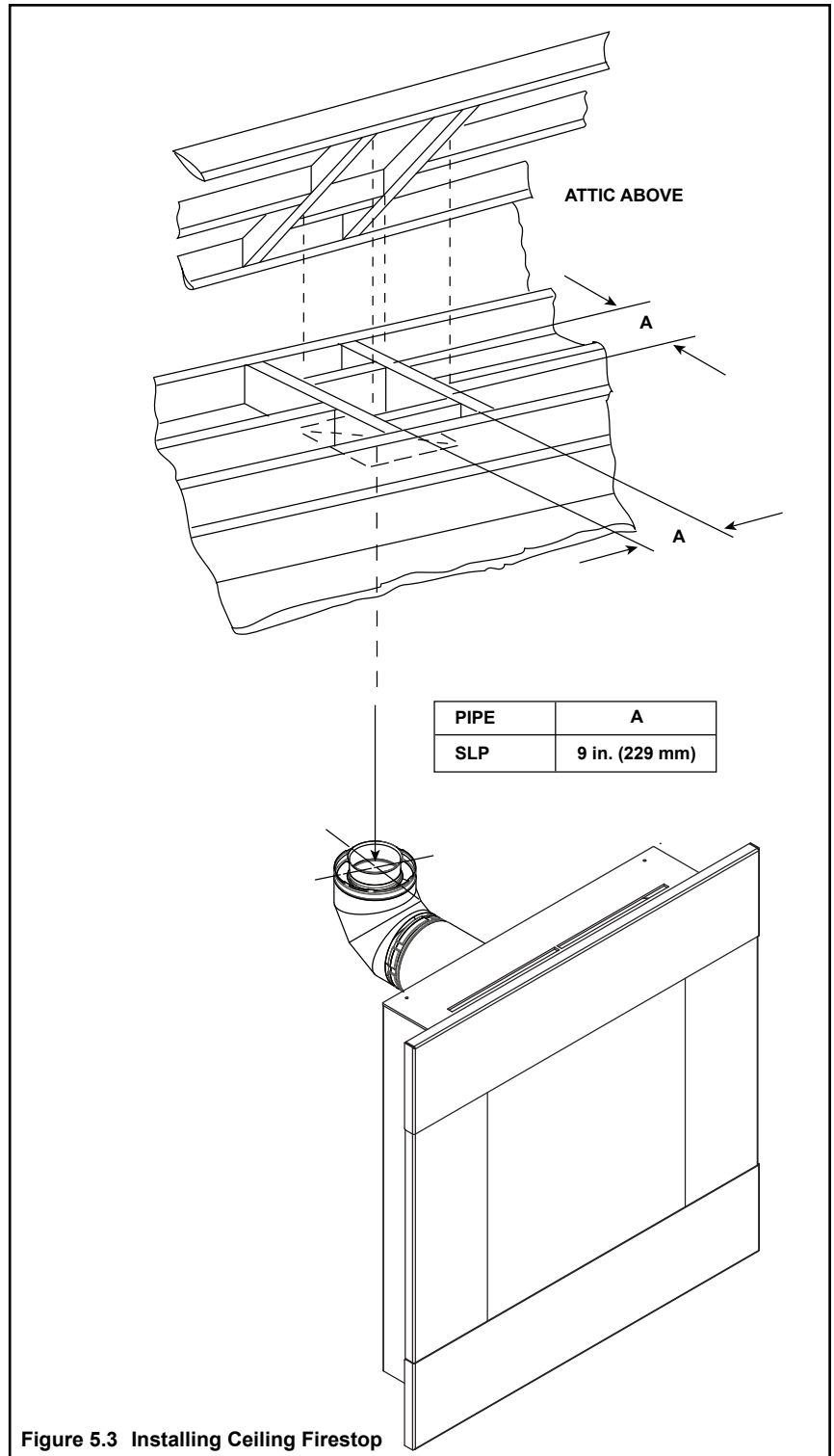

Figure 5.3 Installing Ceiling Firestop

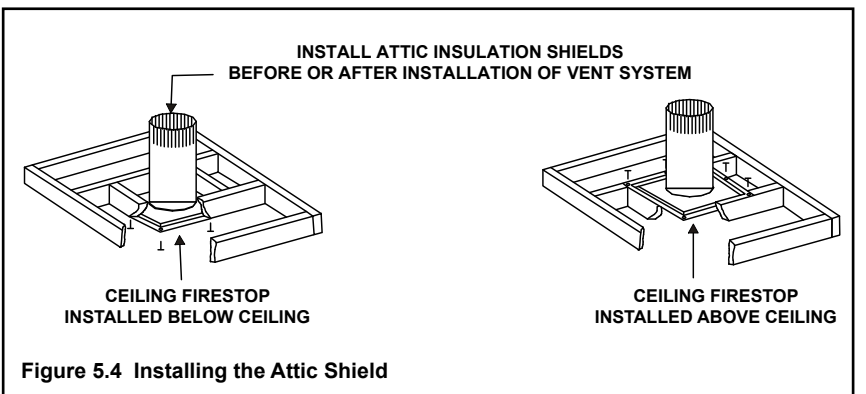

Figure 5.4 Installing the Attic Shield

6 Appliance Preparation

A. Vent Collar Preparation - Sealing the Firestop

CAUTION! Risk of Cuts, Abrasions or Flying Debris. Wear protective gloves and safety glasses during installation. Sheet metal edges are sharp.

NOTICE: Cold air infiltration may occur if firestop is not sealed correctly.

1. Seal the firestop on the interior and exterior by caulking around the perimeter using caulk with a 300°F minimum continuous exposure rating. See Figure 6.1. and 6.2.

WARNING! Risk of Fire or Explosion! DO NOT break caulk seals on slip sections. Use care when removing termination cap from slip pipe. If slip section seals are broken during removal of the termination cap, vent may leak.

The ION may be installed in the wall or hung on the wall. For In-Wall installations, see Section 11.



Figure 6.1. Firestop - Exterior View

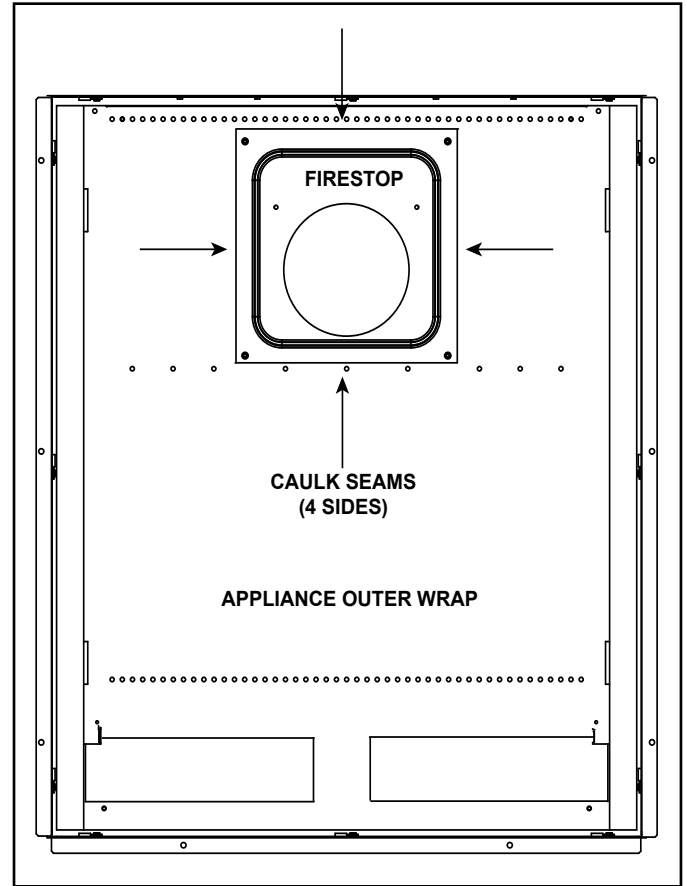

Figure 6.2. Firestop - Interior View

B. Install Appliance Corrugated Template (On-Wall Installation)

For new construction installations in which the ION will be mounted flush on the wall, the following preparations must be made. A Corrugated Template may be used to simplify the installation process. Contact your dealer or see Service Parts section in Owner's manual to order. Using the template for new construction installations of the ION will help when locating the gas and electrical connections for the appliance. Template layout dimensions for each specific model are provided in Figures 6.5, 6.6, and 6.7.

1. Determine the location of the appliance.
2. Hang corrugated template on studs using a permanent method such as nails, staples, tacks or screws.
3. Bring electrical and gas hookups to locations designated by markings on corrugated template.

Note: Hard-piped gas connections must be terminated with a specific "Z" dimension depth. See references to "Z" dimension in Figure 6.3. Terminating the Hard-piped gas connection with the proper "Z" dimension will simplify the process of connecting the gas to the appliance.

WARNING! Risk of overheating! Install appliance a minimum of 4 inches off of finished floor.

- Convection air flow could be compromised and cause overheating.
- Decorative fronts will not fit properly.

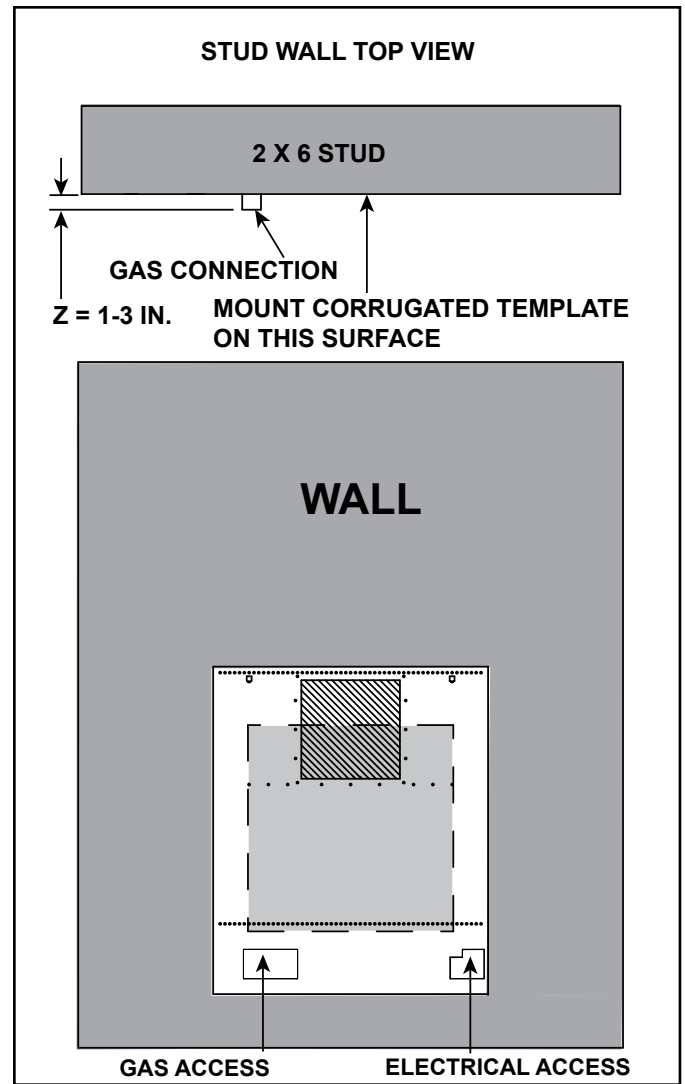

Figure 6.3 Hard-Piped Gas Line Termination and Electrical Service

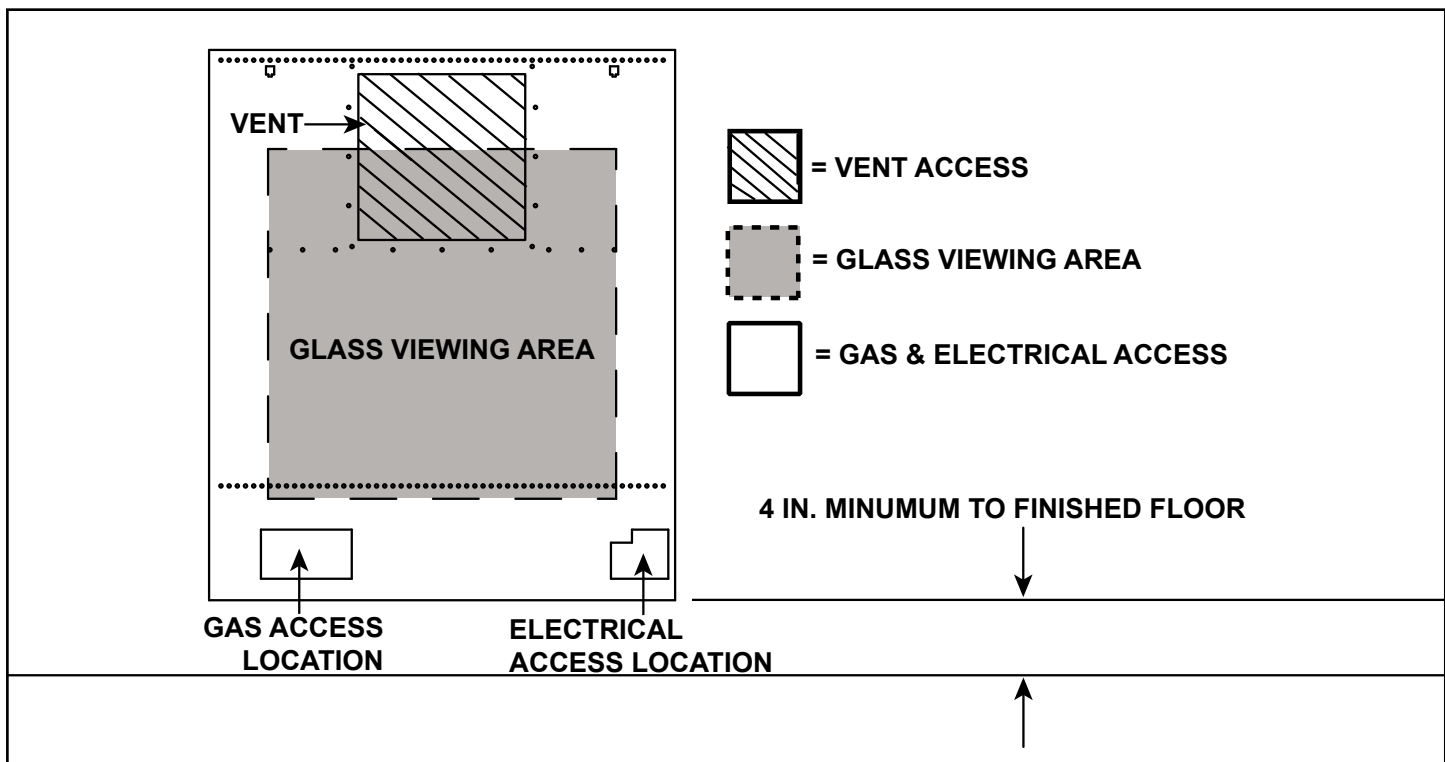

Figure 6.4 Corrugated Template Layout

ION-V7

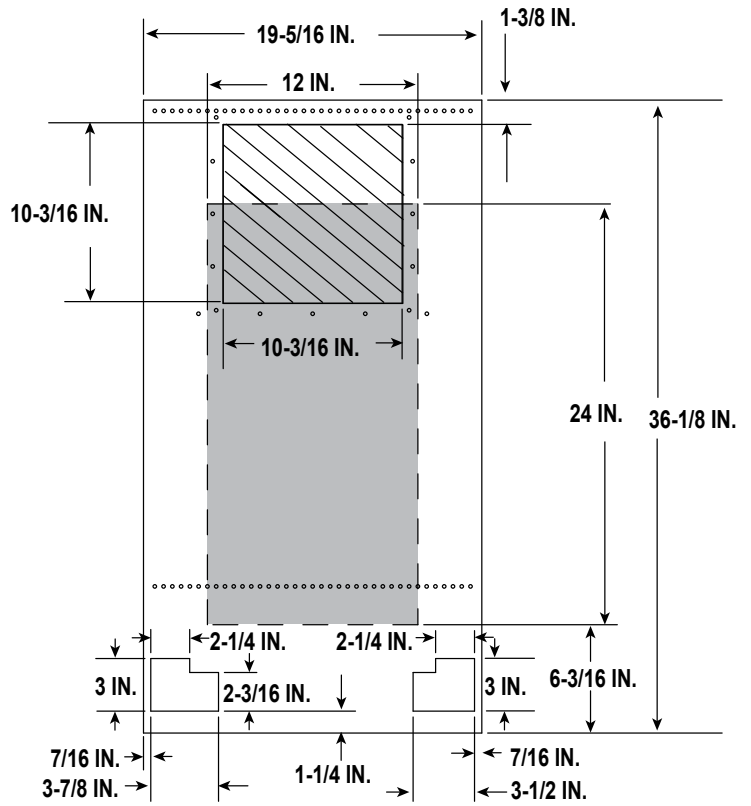
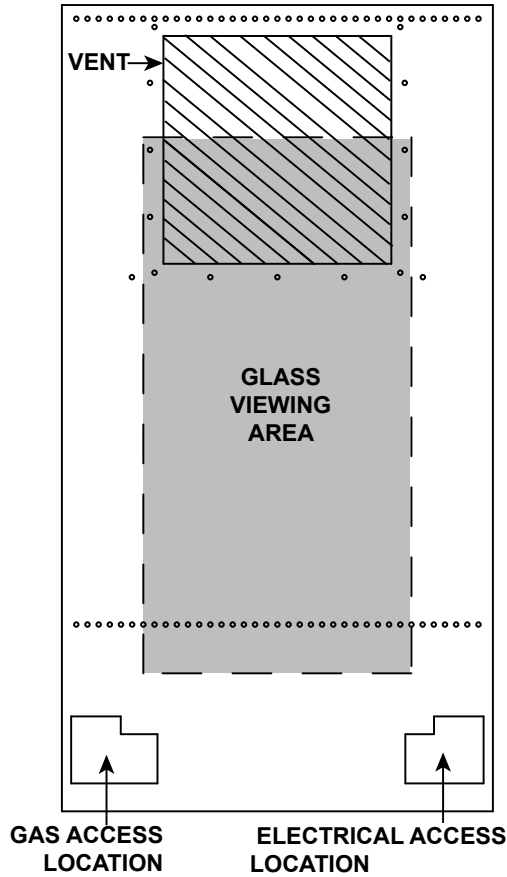

Figure 6.5 Corrugated Template Dimensions - ION-V7

ION-S7

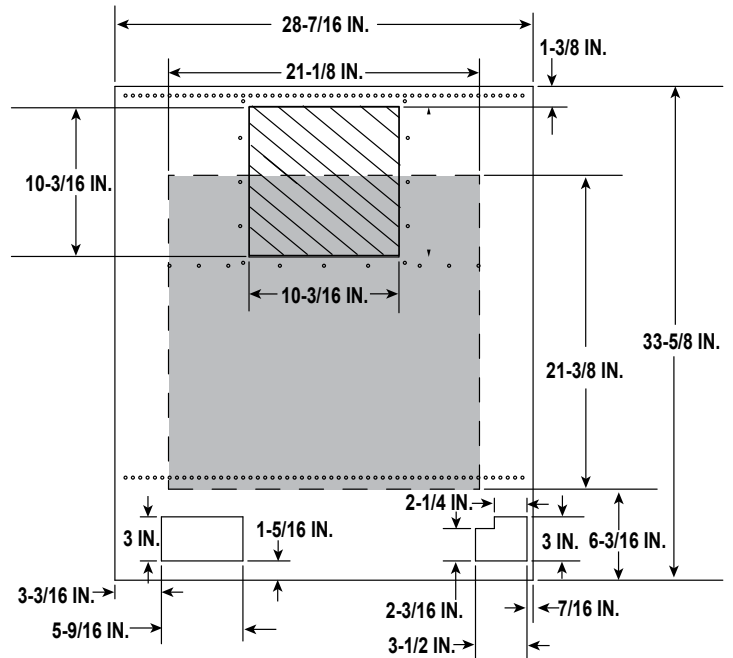
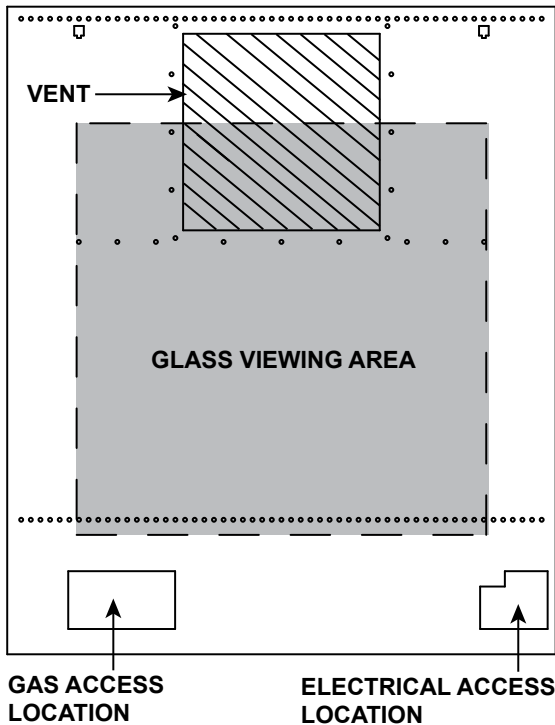

Figure 6.6 Corrugated Template Dimensions - ION-S7

ION-H7

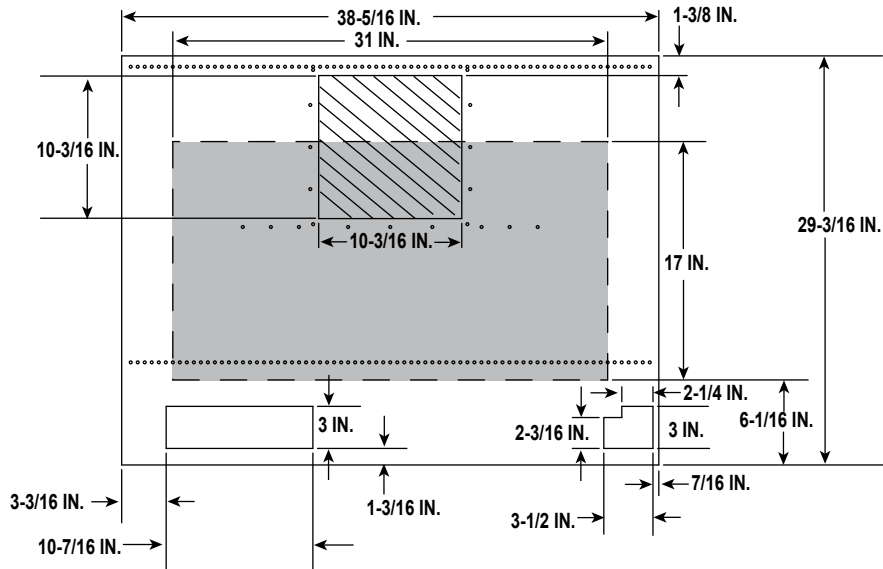
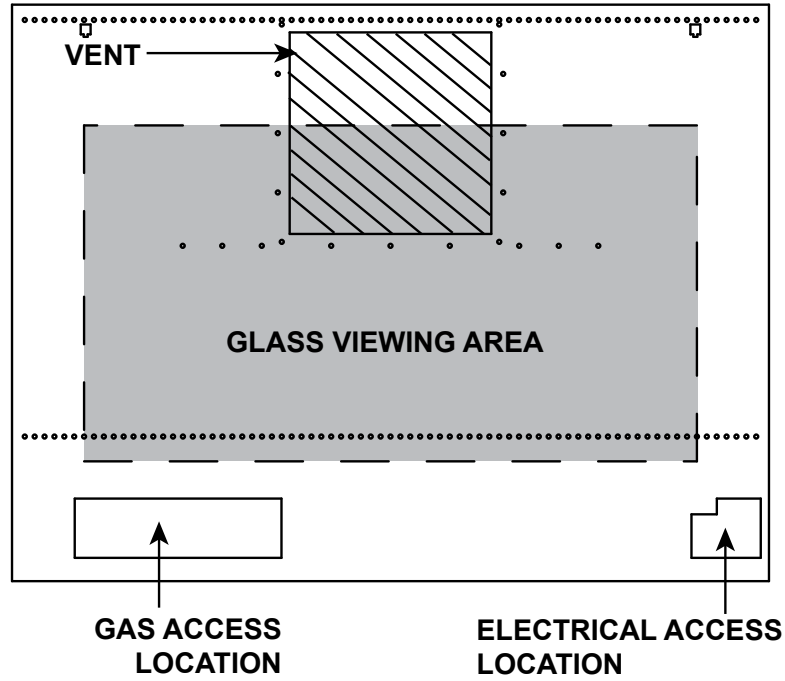

Figure 6.7 Corrugated Template Dimensions - ION-H7

C. Install Appliance Outer Wrap (On-Wall Installation)

1. Remove the glass assembly from the firebox by releasing the two top glass latches and then the two bottom glass latches. See Figure 12.1.
2. Remove the screws that attach the firebox to the outer wrap. See Figure 6.8. Separate the firebox from the outer wrap. Carefully set the firebox aside holding it by the sides. Do not grab, lift or carry the appliance by the top heat shield, or component tray. Lay the appliance on its back to avoid damaging the component tray.
Note: Do not remove outer heat shields.
3. Position the outer wrap on the wall and ensure it is level. See Figure 6.9. A minimum of two screws must be attached to the vertical wall studs. Secure with the fasteners provided. See Figure 6.11(C) and Figure 6.12.

CAUTION! Outer wrap and appliance MUST be installed level for proper burner operation.

4. Cut hole through wall as indicated in Figure 6.9. You may use the appliance outer wrap as a guide.

WARNING! Risk of Fire! Prevent contact with:

- Sagging or loose insulation
- Insulation backing or plastic
- Framing and other combustible materials

Block openings into the chase to prevent entry of blown-in insulation. Make sure insulation and other materials are secured.

Failure to maintain air space clearance could cause overheating and fire.

5. Frame around the edges of the firestop cut out to ensure insulation does not come into contact with the vent pipe. See Figure 6.10 and 6.12.
6. Install wall firestop with four screws. See Figure 6.10 and Figure 6.11(C).
7. Seal the wall firestop. See Section 6.A.

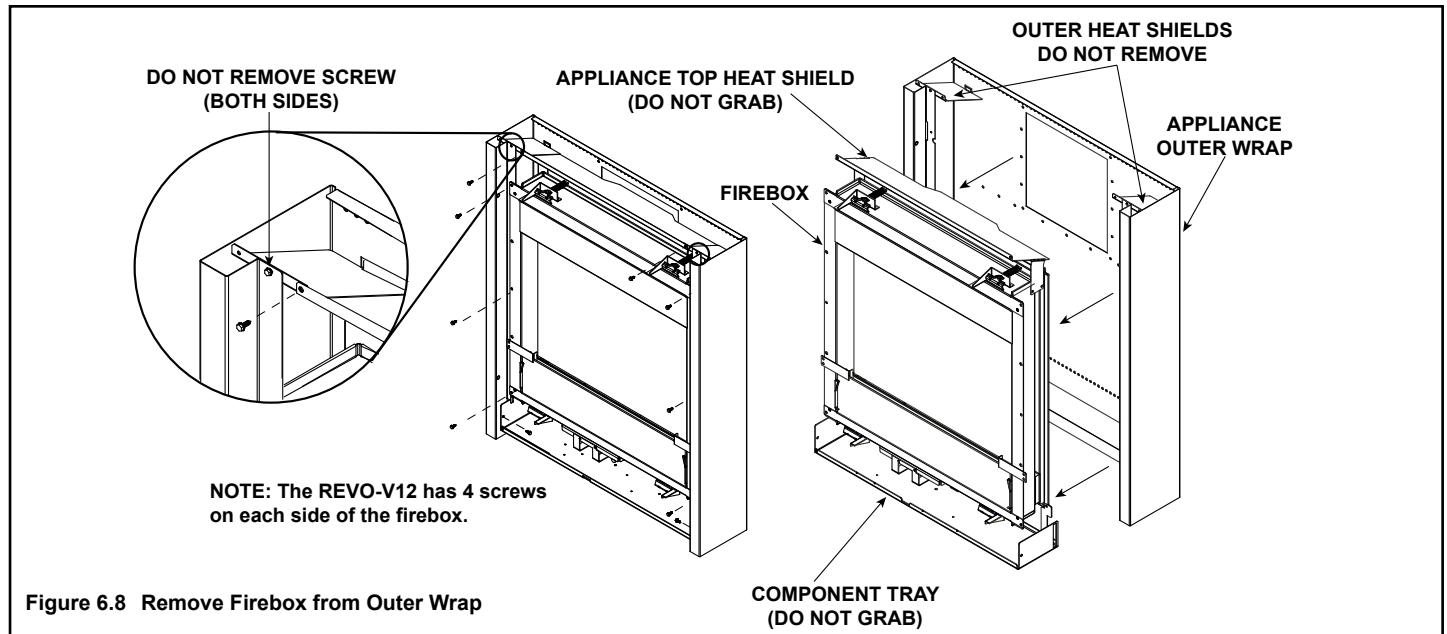

Figure 6.8 Remove Firebox from Outer Wrap

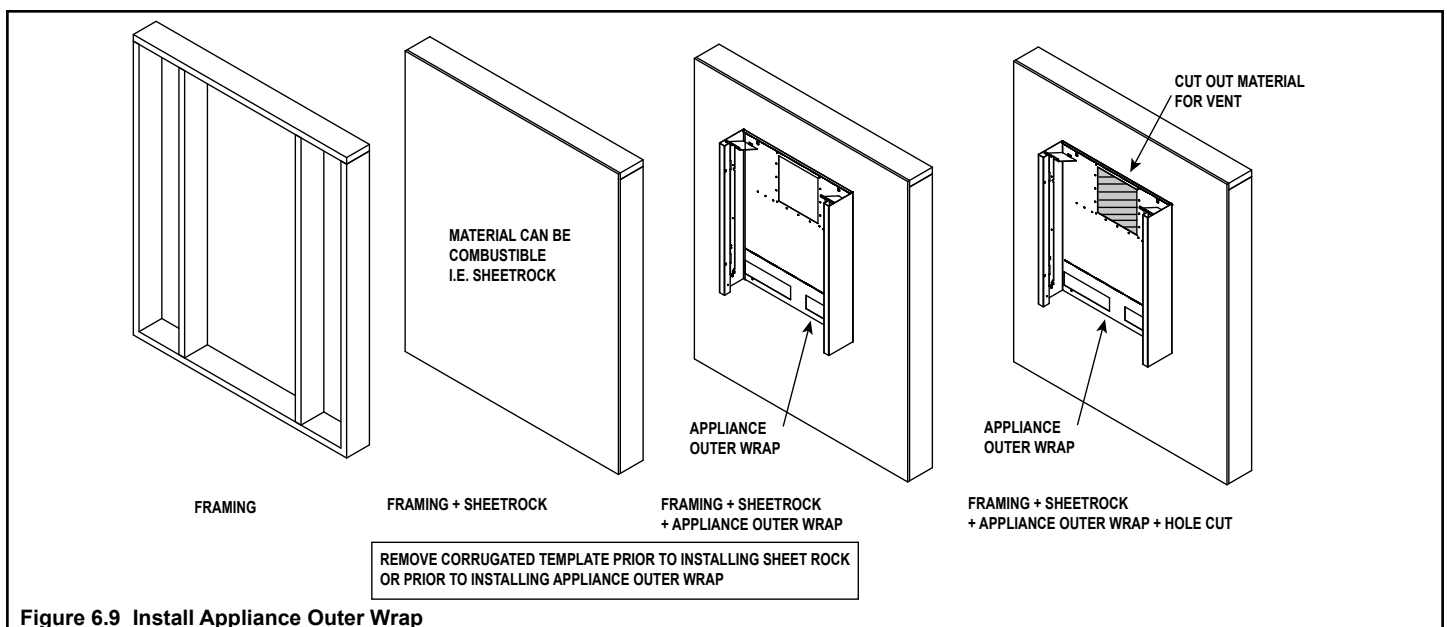

Figure 6.9 Install Appliance Outer Wrap

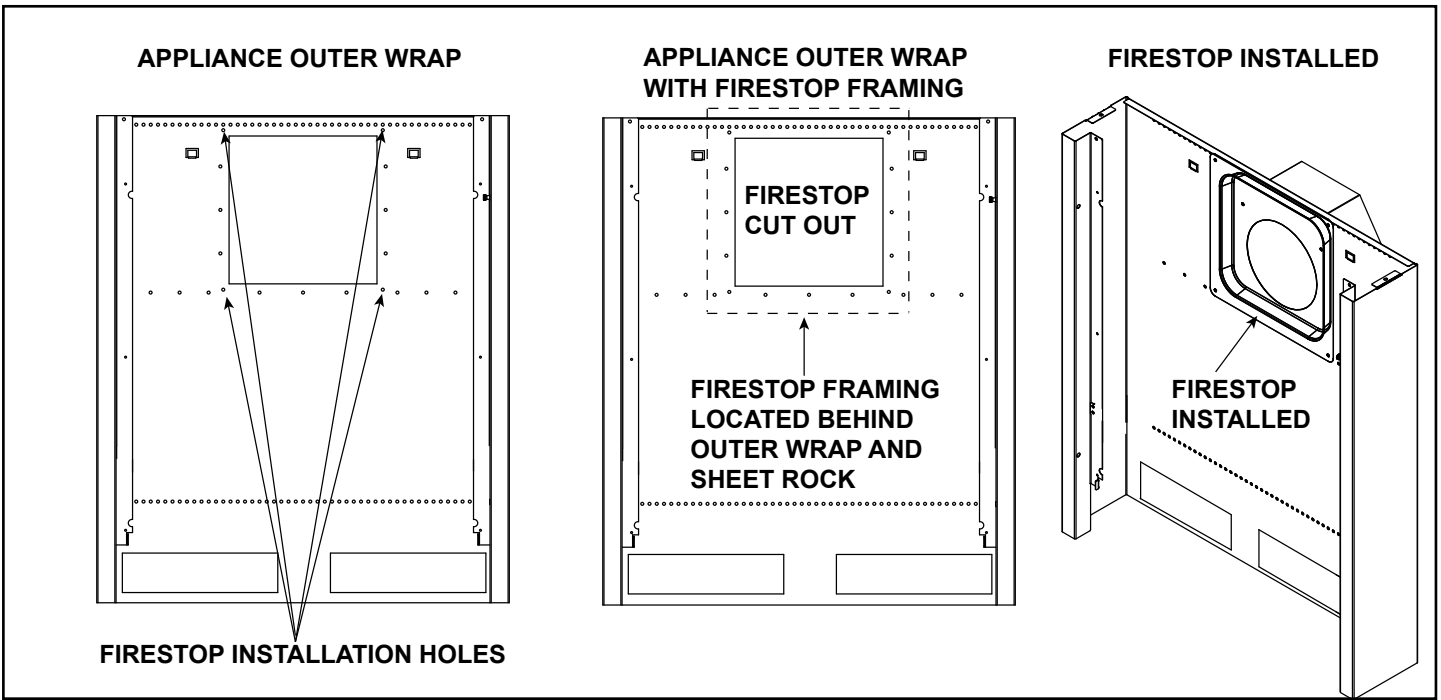

Figure 6.10. Install Firestop and Firestop Framing

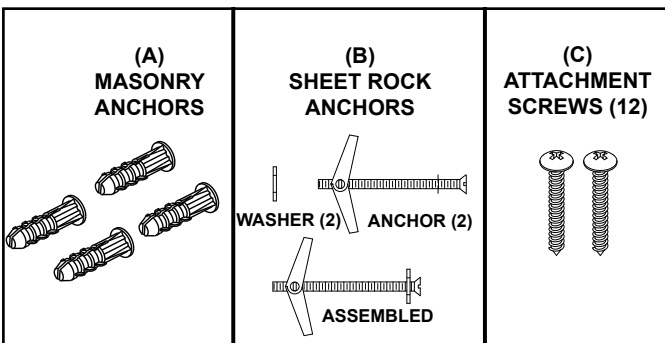

Figure 6.11 Masonry Anchors and Sheet Rock Anchors

8. When attaching to a brick (masonry) wall, use masonry anchors. See Figure 6.11 (A).
9. A minimum of two screws must be used to attach the appliance to vertical wall studs. See Figure 6.11 (C). Use sheet rock anchors if a wall stud is not available on either or both sides of the appliance outer wrap. See Figure 6.11 (B).
10. Install the firebox onto the outer wrap as directed in Section 6.D.
11. Replace the glass assembly on the appliance. Latch the two bottom glass assembly latches and then the two top glass latches. See Figure 12.1.
12. Attach the appliance vent system. See Section 6.A for reference to sealing firestop. An SLP-TRAP2 will be needed when hanging the appliance on a 2 x 6 wall.

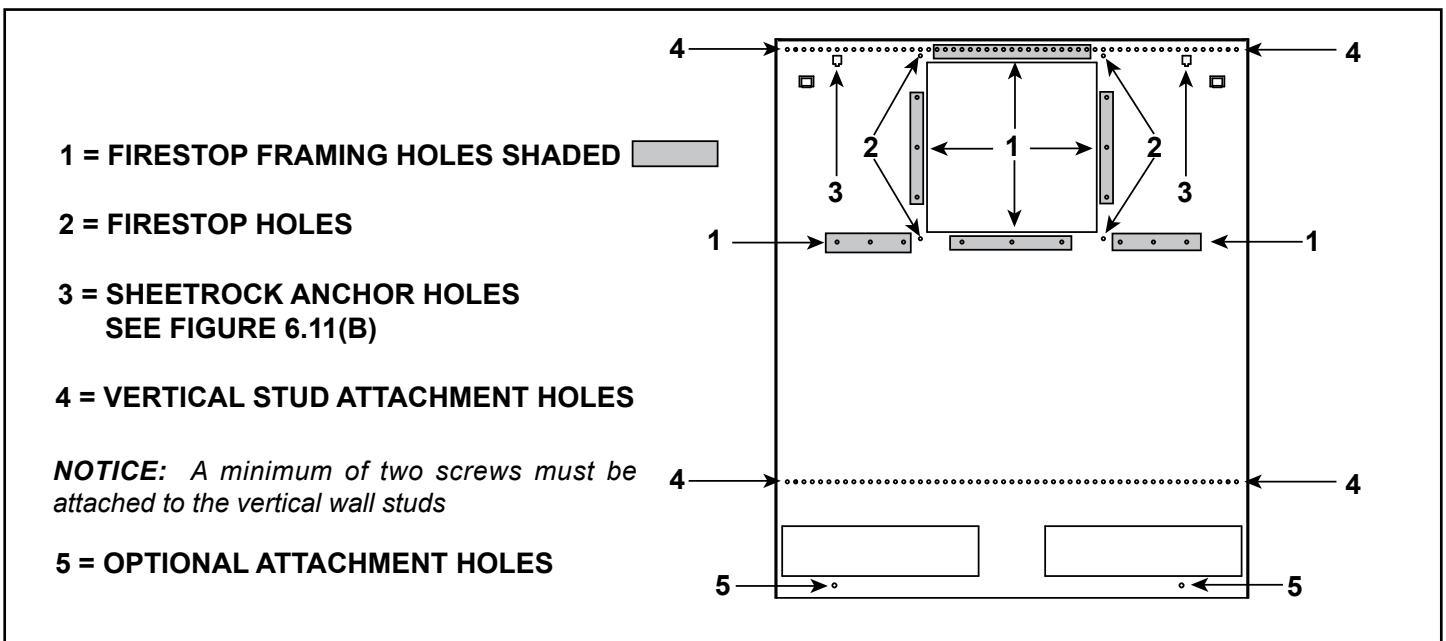

Figure 6.12 Outer Wrap Mounting Feature Identification

D. Install Appliance Into Outer Wrap (On-Wall Installation)

1. Install the firebox into the outer wrap by mating the tabs on the outer wrap with the notches located on the lower left and right bottom corners of the firebox. Do not grab, lift or carry the appliance by the top heat shield, or component tray. See Figure 6.13. The process of mating the tabs and notches accommodates the alignment of the screws with the corresponding holes. The tabs on the outer wrap should be bent outward as shown in Figure 6.13. Reinstall screws using Figure 6.8 as a reference.

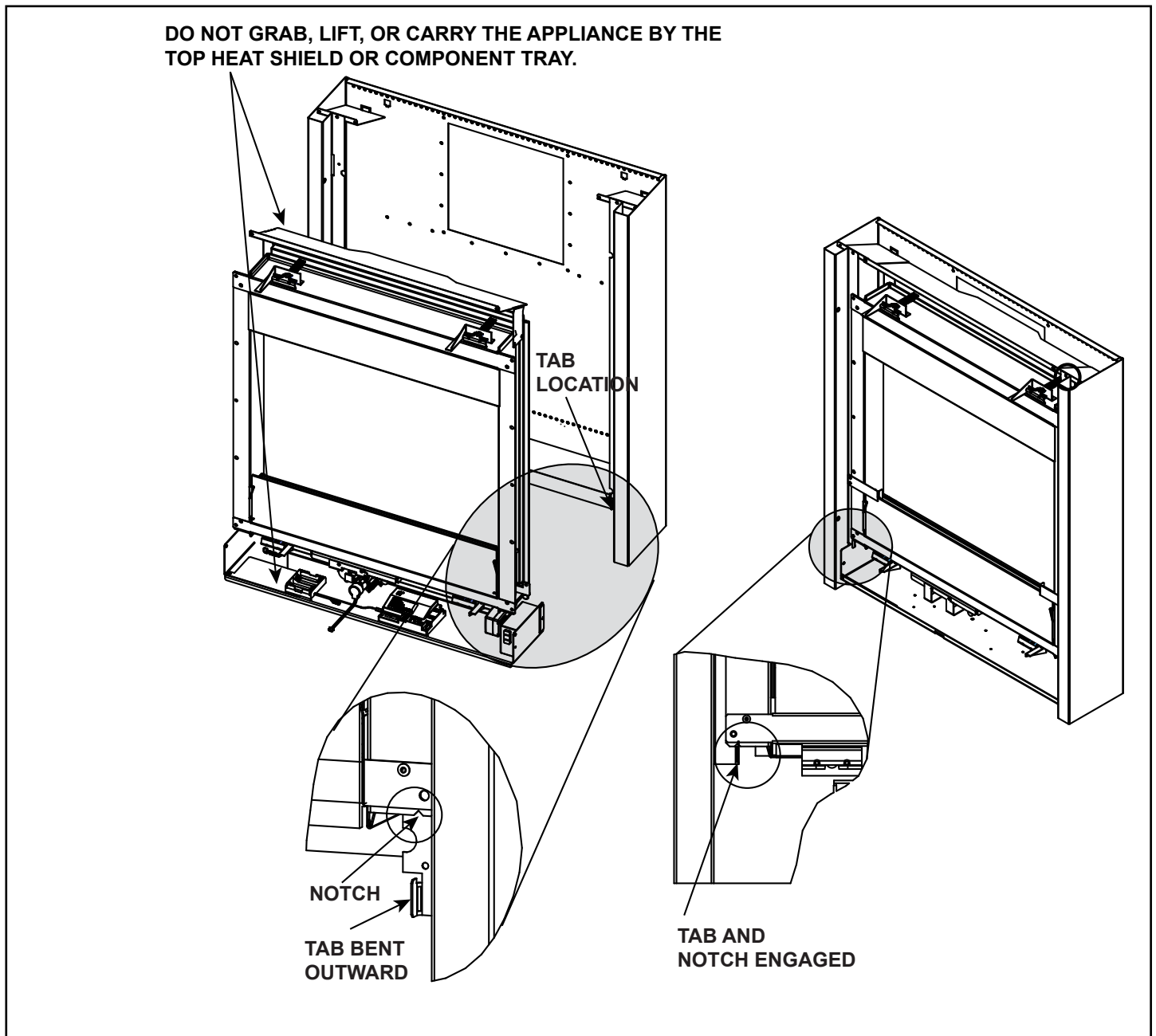

Figure 6.13 Install Firebox On Appliance Outer Wrap

7 Venting and Chimneys

A. Assemble Vent Sections

To attach the first vent component to the starting collars of the appliance:

- Lock the vent components into place by sliding the pipe section onto the collar.
- Align the seam of the pipe and seam of collar to allow engagement. Rotate the vent component to lock into place. Use this procedure for all vent components. See Figure 7.1.
- Slide the gasket over the first vent section and place it flush to the appliance. This will prevent cold air infiltration. Caulk with a minimum of 300°F continuous exposure rating may be used to hold the part in place.
- Continue adding vent components, locking each succeeding component into place.
- Ensure that each succeeding vent component is securely fitted and locked into the preceding component.

Commercial, Multi-family (Multi-level exceeding two stories), or High-Rise Applications

For Installation into a commercial, multi-family (multi-level exceeding two stories) or high-rise applications: All outer pipe joints must be sealed with high temperature silicone (300°F minimum continuous exposure rating), including the slip section that connects directly to the horizontal termination cap.

- Apply a bead of silicone sealant (300°F minimum continuous exposure rating) inside the female outer pipe joint prior to joining sections. See Figure 7.2.
- Only outer pipes need to be sealed. All unit collar, pipe, slip section, elbow and cap outer flues shall be sealed in this manner, unless otherwise stated.

WARNING! Risk of Fire or Explosion! DO NOT break silicone seals on slip sections. Use care when removing termination cap from slip pipe. If slip section seals are broken during removal of the termination cap, vent could leak.

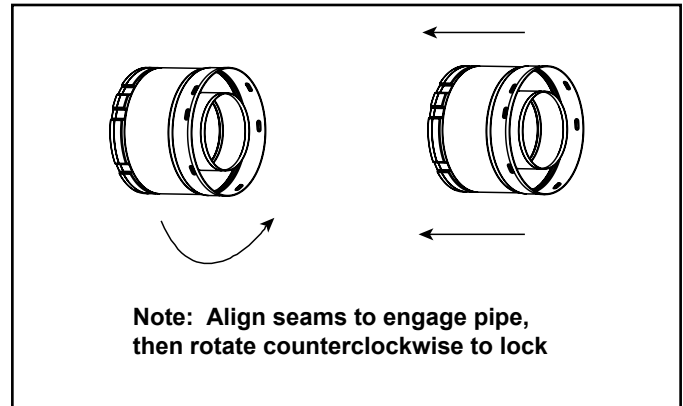

Figure 7.1 Adding Venting Components



Figure 7.2 High Temperature Silicone Sealant

B. Installing Slip Sections

- Slide the inner flue of the slip section into the inner flue of the pipe section and the outer flue of the slip section over the outer flue of the pipe section. See Figure 7.3.
- Slide together to the desired length.

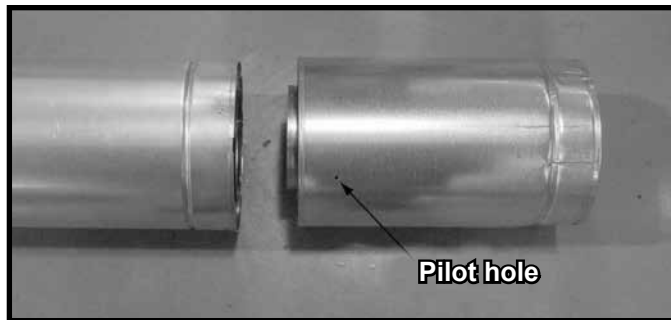

Figure 7.3 Slip Section Pilot Holes

- Maintain a 1-1/2 in. (38 mm) overlap between the slip section and the pipe section.
- Secure the pipe and slip section with two screws no longer than 1/2 in. (13 mm), using the pilot holes in the slip section. See Figure 7.4

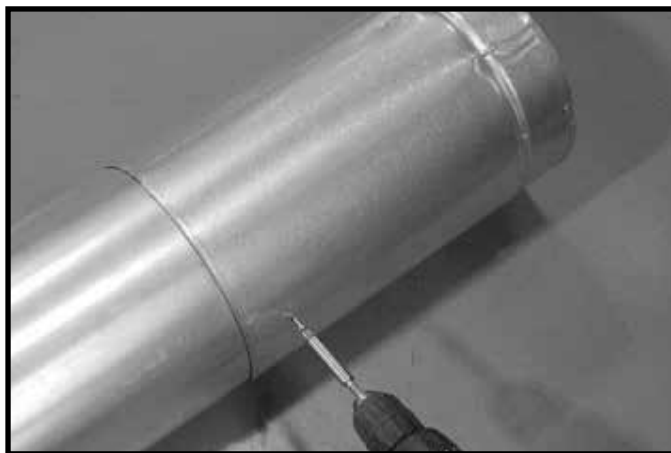

Figure 7.4 Screws into Slip Section

- Continue adding pipe as necessary following instructions in “Assembling Pipe Sections.”

NOTICE: If slip section is too long, the inner and outer flues of the slip section can be cut to the desired length.

NOTICE: When installing a vent system with an HRC termination cap, all pipe system joints shall be sealed using a high temperature silicone sealant (300°F minimum continuous exposure rating).

- Apply a bead of silicone sealant (300°F minimum continuous exposure rating) inside the female outer pipe joint prior to joining sections.
- Only outer pipes are sealed, sealing the inner flue is not required.
- All unit collar, pipe, slip section, elbow and cap outer flues shall be sealed.

C. Secure the Vent Sections

- Vertical runs originating off the top of the appliance, with no offsets, must be supported every 8 ft. (2.44 m) after the maximum allowed 25 ft. (7.62 m) of unsupported rise.
- Vertical runs originating off the rear of the appliance, or after any elbow, must be supported every 8 ft. (2.44 m).
- Horizontal runs must be supported every 5 feet (1.52 m).
- Vent supports or plumbers strap (spaced 120° apart) may be used to support vent sections. See Figures 7.5 and 7.6.
- Wall shield firestops may be used to provide horizontal support to vent sections.
- SLP ceiling firestops have tabs that may be used to provide vertical support.

WARNING! Risk of Fire, Explosion or Asphyxiation! Improper support could allow vent to sag and separate. Use vent run supports and connect vent sections per installation instructions. **DO NOT** allow vent to sag below connection point to appliance.

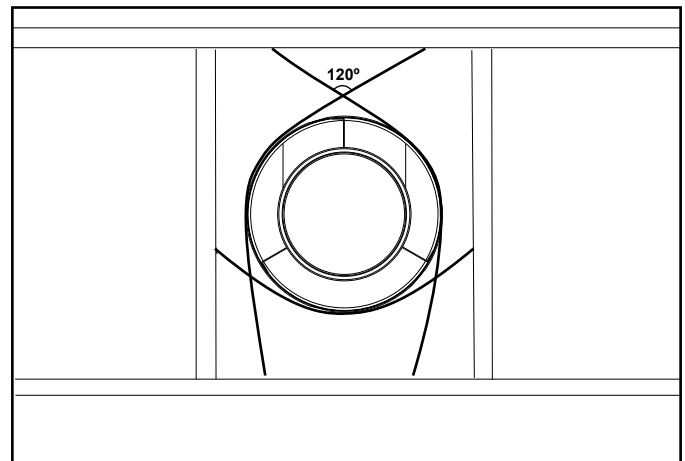

Figure 7.5 Securing Vertical Pipe Sections

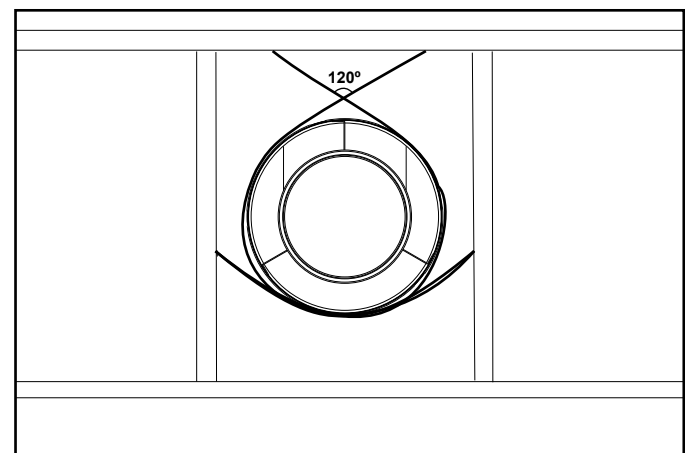

Figure 7.6 Securing Horizontal Pipe Sections

D. Disassemble Vent Sections

- Rotate either section (see Figure 7.7) so the seams on both pipe sections are aligned as shown in Figure 7.8.
- Pull carefully to separate the pieces of pipe.

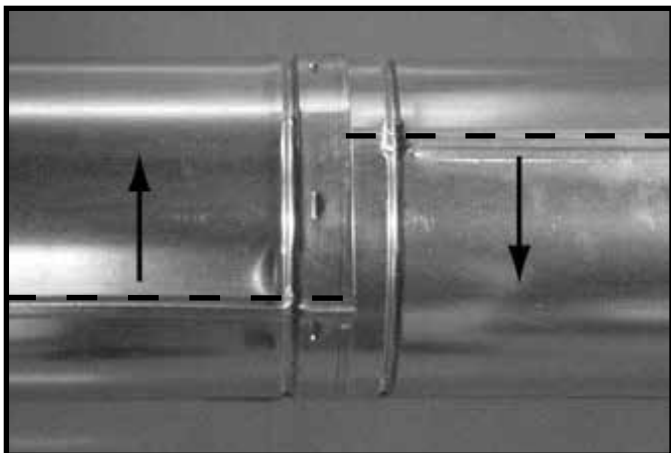

Figure 7.7 Rotate Seams for Disassembly

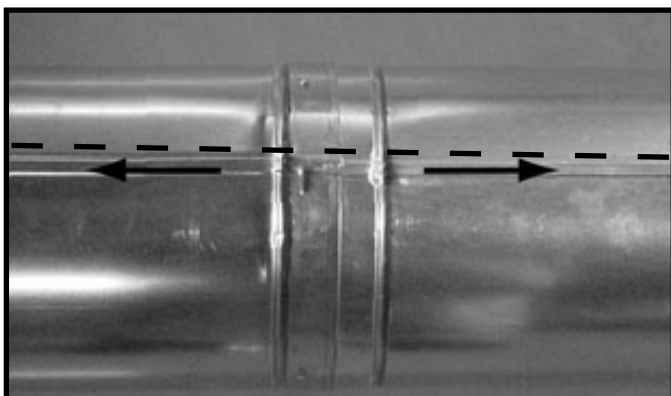
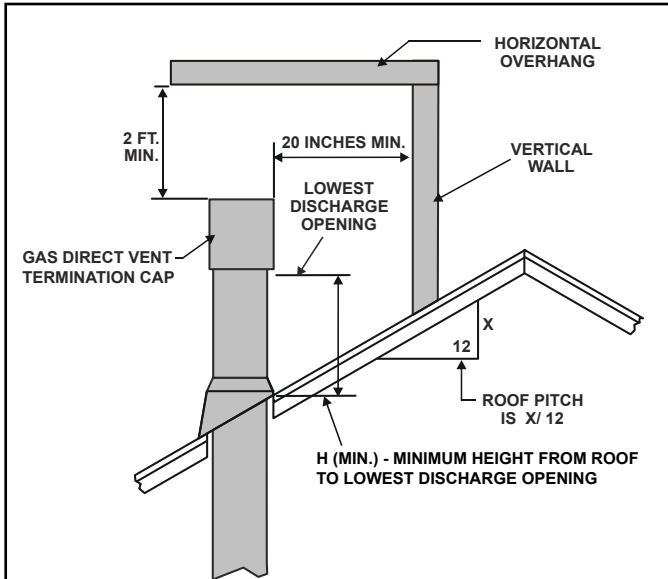

Figure 7.8 Align and Disassemble Vent Sections

E. Vertical Termination Requirements

Install Metal Roof Flashing

- See minimum vent heights for various pitched roofs (Figure 7.9) to determine the length of pipe to extend through the roof.
- Slide the roof flashing over the pipe sections extending through the roof as shown in Figure 7.10.



<u>Roof Pitch</u>	<u>H (Min.) Ft.</u>
Flat to 6/12.....	1.0*
Over 6/12 to 7/12.....	1.25*
Over 7/12 to 8/12.....	1.5*
Over 8/12 to 9/12.....	2.0*
Over 9/12 to 10/12.....	2.5*
Over 10/12 to 11/12.....	3.25
Over 11/12 to 12/12.....	4.0
Over 12/12 to 14/12.....	5.0
Over 14/12 to 16/12.....	6.0
Over 16/12 to 18/12.....	7.0
Over 18/12 to 20/12.....	7.5
Over 20/12 to 21/12.....	8.0

* 3 foot minimum in snow regions

Figure 7.9 Minimum Height From Roof To Lowest Discharge Opening

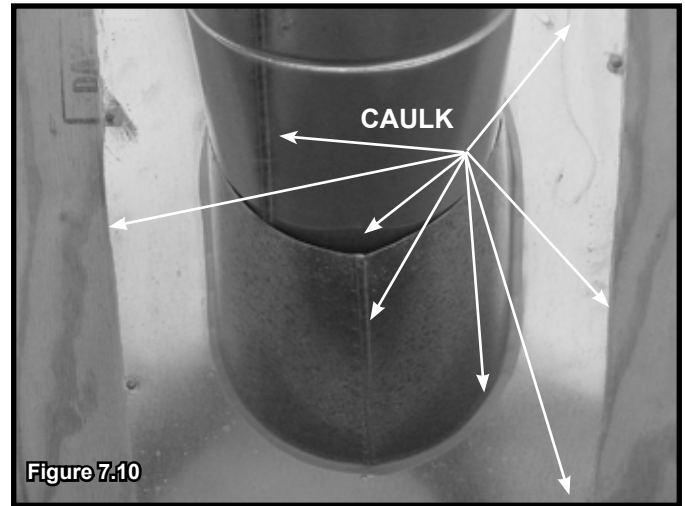

Assemble and Install Storm Collar

CAUTION! Risk of Cuts, Abrasions or Flying Debris. Wear protective gloves and safety glasses during installation. Sheet metal edges are sharp.

- Slide the storm collar onto the exposed pipe section and align brackets.
- Insert a bolt (provided) through the brackets and install nut. Do not completely tighten.



- Slide the assembled storm collar down the pipe section until it rests on the roof flashing (see Figure 7.11).
- Tighten nut and make sure the collar is tight against the pipe section.
- Caulk around the top of the storm collar. See Figure 7.11.

NOTICE: Failure to properly caulk the roof flashing and pipe seams could permit entry of water.

- Caulk the gap between the roof flashing and the outside diameter of the pipe.
- Caulk the perimeter of the flashing where it contacts the roof surface. See Figure 7.10.
- Caulk the overlap seam of any exposed pipe sections that are located above the roof line.

Install Vertical Termination Cap

- Attach the vertical termination cap by sliding the inner collar of the cap into the inner flue of the pipe section while placing the outer collar of the cap over the outer flue of the pipe section.
- Secure the cap by driving three self-tapping screws (supplied) through the pilot holes in the outer collar of the cap into the outer flue of the pipe (see Figure 7.12).



F. Horizontal Termination Requirements

Heat Shield Requirements for Horizontal Termination

WARNING! Risk of Fire! To prevent overheating and fire, heat shields must extend through the entire wall thickness.

- **DO NOT** remove the heat shields attached to the wall shield firestop and the horizontal termination cap (shown in Figure 7.13).
- Heat shields must overlap 1-1/2 in. (38 mm) minimum.

There are two sections of the heat shield. One section is factory-attached to the wall shield firestop. The other section is factory-attached to the cap. See Figure 7.13.

If the wall thickness does not allow the required 1-1/2 in. (38 mm) heat shield overlap when installed, an extended heat shield must be used.

- If the wall thickness is less than 4-3/8 in./ 111 mm (SLP), the heat shields on the cap and wall shield firestop must be trimmed. A minimum 1-1/2 in. (38 mm) overlap **MUST** be maintained.
- Use an extended heat shield if the finished wall thickness is greater than 7-1/4 in. (184 mm).
- The extended heat shield may need to be cut to length maintaining sufficient length for a 1-1/2 in. (38 mm) overlap between heat shields.
- Attach the extended heat shield to either of the existing heat shields using the screws supplied with the extended heat shield. Refer to vent components diagrams in the back of this manual.
- Rest the small leg on the extended heat shield on top of the pipe section to properly space it from the pipe section.

Important Notice: Heat shields may not be field constructed.

Install Horizontal Termination Cap

WARNING! Risk of Fire! The telescoping flue section of the termination cap **MUST** be used when connecting vent.

- 1-1/2 (38 mm) minimum overlap of flue telescoping section is required.

Failure to maintain overlap could cause overheating and fire.

- Vent termination must not be recessed in the wall. Siding may be brought to the edge of the cap base.
- Flash and seal as appropriate for siding material at outside edges of cap.
- When installing a horizontal termination cap, follow the cap location guidelines as prescribed by current **ANSI Z223.1** and **CAN/CGA-B149** installation codes and refer to Section 4 of this manual.

CAUTION! Risk of Burns! Local codes may require installation of a cap shield to prevent anything or anyone from touching the hot cap.

NOTICE: For certain exposures which require superior resistance to wind-driven rain penetration, a flashing kit and HRC caps are available. When penetrating a brick wall, a brick extension kit is available for framing the brick.

Note: When using termination caps with factory-supplied heat shield attached, no additional wall shield firestop is required on the exterior side of a combustible wall.

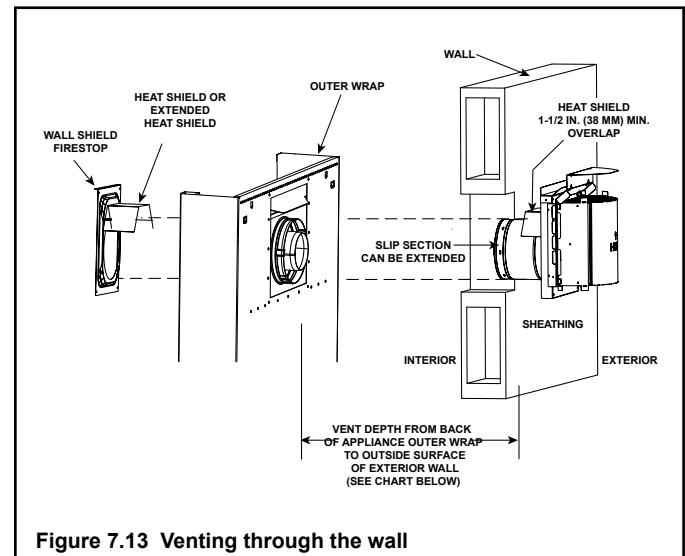

Figure 7.13 Venting through the wall

Termination Cap Specification Chart (Depth without using additional pipe sections)	
SLP-TRAP1	can adjust 2-3/8 in. (4-1/8 in. to 6-1/2 in.)
SLP-TRAP2	can adjust 4-1/2 in. (6-1/2 in. to 11 in.)

8 Electrical Information

A. General Information

WARNING! Risk of Shock or Explosion! DO NOT wire 110-120 VAC to the valve or to the appliance wall switch. Incorrect wiring will damage controls.

NOTICE: This appliance must be electrically wired and grounded in accordance with local codes or, in the absence of local codes, with **National Electric Code ANSI/NFPA 70-latest edition or the Canadian Electric Code CSA C22.1.**

- Wire the appliance junction box to unswitched 110-120 VAC. This is required for proper operation of the appliance.
- A 110-120 VAC circuit for this product must be protected with ground-fault circuit-interrupter protection, in compliance with the applicable electrical codes, when it is installed in locations such as in bathrooms or near sinks.
- Low voltage and 110-120 VAC voltage cannot be shared within the same wall box.

Electrical Service and Repair

WARNING! Risk of Shock! Label all wires prior to disconnection when servicing controls. Wiring errors could cause improper and dangerous operation. Verify proper operation after servicing.

WARNING! Risk of Shock! Replace damaged wire with type 105° C rated wire. Wire must have high temperature insulation.

Junction Box Installation

If the box is being wired from the **INSIDE** of the appliance:

- Remove the screw attaching the junction box/receptacle. Rotate the junction box inward to disengage it. See Figure 8.1.
- Pull the electrical wires from outside the appliance through the opening into the valve compartment and secure wires with a Romex connector. See Figure 8.1.
- Make all necessary wire connections to the junction box/receptacle and position and secure the junction box/receptacle into its original position.

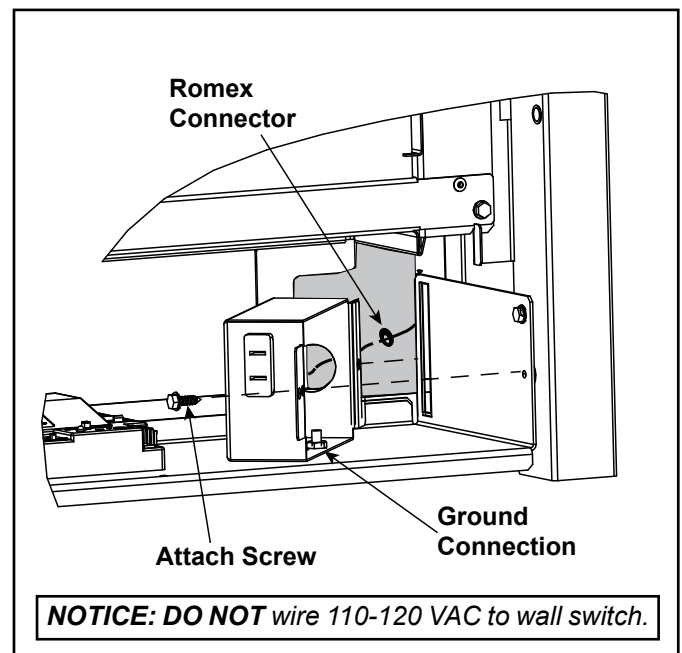

Figure 8.1 Junction Box Detail

Accessories Requirements

- This appliance may be used with a wall switch, wall mounted thermostat and/or a remote control.

Wiring for optional Hearth & Home Technologies approved accessories should be done now to avoid reconstruction. Follow instructions that come with those accessories.

B. Wiring Requirements

Intellifire™ Plus Ignition System Wiring

- Wire the appliance junction box to 110-120 VAC for proper operation of the appliance.

WARNING! Risk of Shock or Explosion! DO NOT wire IPI controlled appliance junction box to a switched circuit. Incorrect wiring will override IPI safety lockout.

- Refer to Figure 8.2, IPI Wiring Diagram.
- This appliance is equipped with an IntelliFire™ Plus control valve which operates on a 6 volt/1.5 AMP system.

- Plug the 6 volt transformer plug into the appliance junction box to supply power to the unit OR install 4 AA cell batteries (not included) into the battery pack before use.

NOTICE: Batteries should only be used as a power source in the event of an emergency power outage. Batteries should not be used as a primary long-term power source. Battery polarity must be correct when installing batteries.

Do not store batteries in the battery pack when the appliance is powered by the 6 volt transformer connected to permanent electrical service.

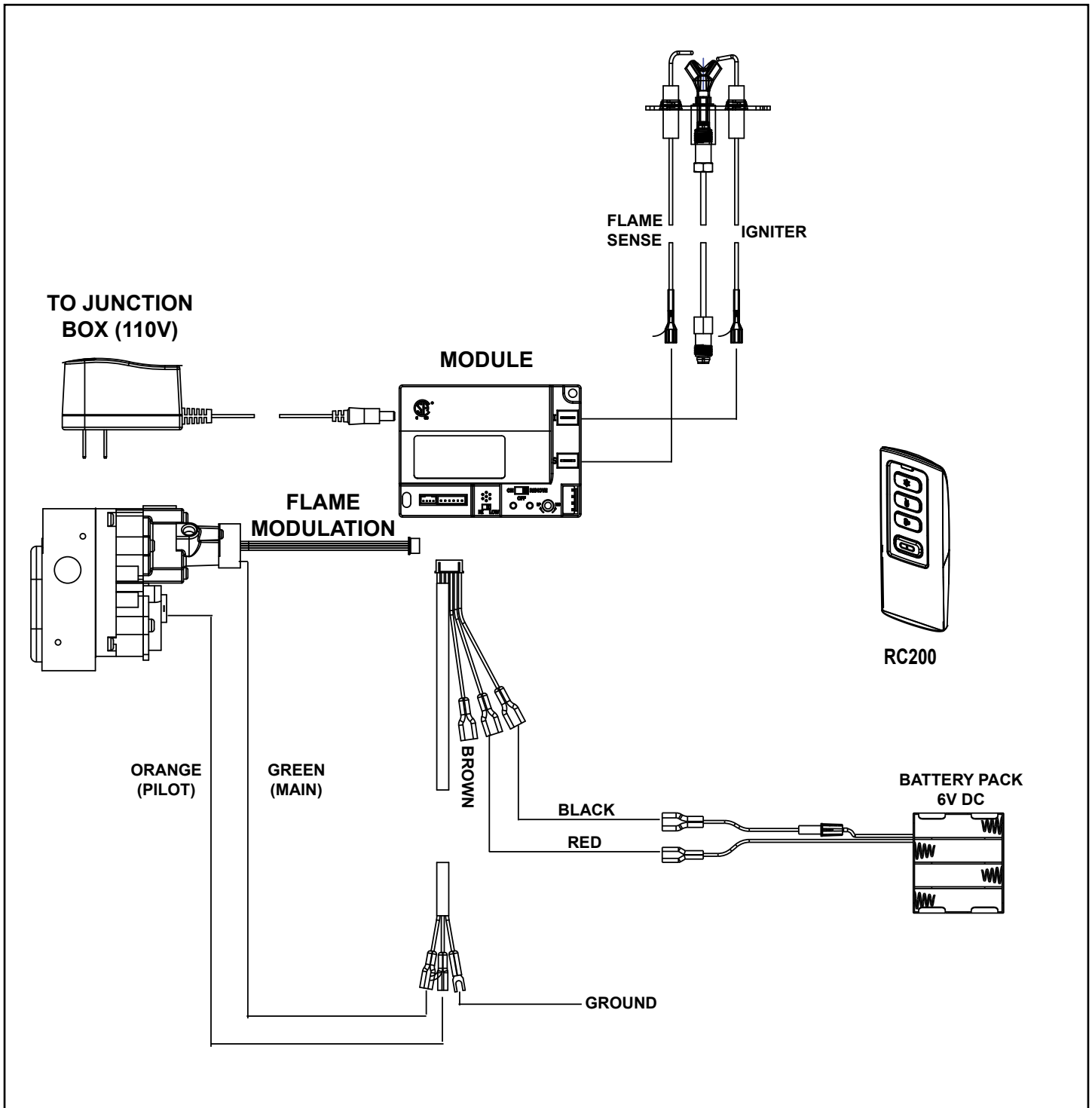

Figure 8.2 Intellifire™ Plus Ignition (IPI) Wiring Diagram

9 Gas Information

A. Fuel Conversion

- Make sure the appliance is compatible with available gas types.
- Conversions must be made by a qualified service technician using Hearth & Home Technologies specified and approved parts.

B. Gas Pressure

- Optimum appliance performance requires proper input pressures.
- Gas line sizing requirements will be determined in ANSI Z223.1 National Fuel Gas Code in the USA and CAN/CGA B149 in Canada.
- Pressure requirements are:

Gas Pressure	Natural Gas	Propane
Minimum inlet pressure	5.0 in. w.c.	11.0 in. w.c.
Maximum inlet pressure	10.0 in. w.c.	13.0 in. w.c.
Manifold pressure	3.5 in. w.c.	10.0 in. w.c.

WARNING! Risk of Fire or Explosion! High pressure will damage valve. Low pressure could cause explosion.

- Verify inlet pressures. Verify minimum pressures when other household gas appliances are operating.
- Install regulator upstream of valve if line pressure is greater than 1/2 psig.

⚠ WARNING



Fire Risk.
Explosion Hazard.
High pressure will damage valve.

- Disconnect gas supply piping BEFORE pressure testing gas line at test pressures above 1/2 psig.
- Close the manual shutoff valve BEFORE pressure testing gas line at test pressures equal to or less than 1/2 psig.

Note: Have the gas supply line installed in accordance with local codes, if any. If not, follow ANSI 223.1. Installation should be done by a qualified installer approved and/or licensed as required by the locality. (In the Commonwealth of Massachusetts installation must be performed by a licensed plumber or gas fitter).

Note: A listed (and Commonwealth of Massachusetts approved) 1/2 in. (13 mm) T-handle manual shut-off valve and flexible gas connector are connected to the 1/2 in. (13 mm) control valve inlet.

- **If substituting for these components, please consult local codes for compliance.**

C. Gas Connection

- Refer to Section 6 for location of gas line access in appliances installed ON the wall. Refer to Section 11 for location of gas line access in appliances installed IN the wall.
- Gas line may be run through knockout(s) provided.
- The gap between supply piping and gas access hole may be caulked with caulk with a minimum of 300°F continuous exposure rating or stuffed with non-combustible, unfaced insulation to prevent cold air infiltration.
- Ensure that gas line does not come in contact with outer wrap of the appliance. Follow local codes.
- Pipe incoming gas line into valve compartment.
- Connect incoming gas line to the 1/2 in. (13 mm) connection on manual shutoff valve.

WARNING! Risk of Fire or Explosion! Support control when attaching pipe to prevent bending gas line.

- A small amount of air will be in the gas supply lines.

WARNING! Risk of Fire or Explosion! Gas build-up during line purge could ignite.

- Purge should be performed by qualified service technician.
- Ensure adequate ventilation.
- Ensure there are no ignition sources such as sparks or open flames.

Light the appliance. It will take a short time for air to purge from lines. When purging is complete the appliance will light and operate normally.

WARNING! Risk of Fire, Explosion or Asphyxiation! Check all fittings and connections with a non-corrosive commercially available leak-check solution. **DO NOT** use open flame. Fittings and connections could have loosened during shipping and handling.

WARNING! Risk of Fire! DO NOT change valve settings. This valve has been preset at the factory.

D. High Altitude Installations

NOTICE: If the heating value of the gas has been reduced, these rules do not apply. Check with your local gas utility or authorities having jurisdiction.

When installing above 2000 feet elevation:

- In the USA: Reduce input rate 4% for each 1000 feet above 2000 feet.
- In CANADA: Input ratings are certified without a reduction of input rate for elevations up to 4500 feet (1370 m) above sea level. Please consult provincial and/or local authorities having jurisdiction for installations at elevations above 4500 feet (1370 m).

Check with your local gas utility to determine proper orifice size.

E. Air Shutter Setting

The ION is shipped with an external adjustable air shutter. Air shutter settings should be adjusted by a qualified service technician at the time of installation. Adjust air shutter for maximum flame appearance. The shutter settings will vary due to fuel type and vent configuration. See Figure 9.1.

To open the air shutter, turn the screw counterclockwise so that the screw goes in and raises the air shutter. Turning the screw clockwise will close the air shutter.

Note: The air shutter is shipped set between 3/8 in. and full open. Adjust shutter to maximize flame appearance.

NOTICE: If sooting occurs, provide more air by opening the air shutter.

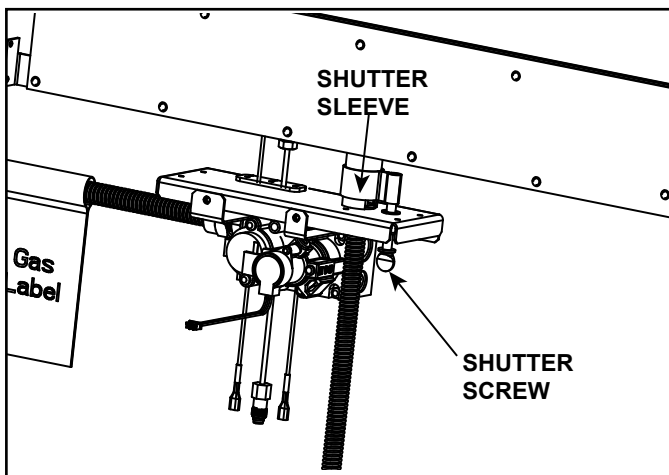

Figure 9.1 Air Shutter

10 Finishing (On-Wall Installation)

A. Facing and Finishing - Fours Square Decorative Fronts

- Facing and/or finishing materials must not interfere with convection vents, operation of doors, or access for service. See Figure 10.1 and Figure 10.3.

WARNING! Risk of Overheating and Fire! Do not allow convection air vents to be blocked or covered. Non-combustible material must not exceed 4 inches in thickness.

- Observe all clearances when applying combustible materials.
- ➔ Remove and discard finishing strip before installing decorative front. See Figure 10.2.
- Use finishing strip to achieve required clearance. See Figure 10.2 and 10.3.

WARNING! Risk of Fire! DO NOT apply combustible materials beyond the minimum clearances. Comply with all minimum clearances to combustibles as specified in this manual. Overlapping materials could ignite and will interfere with proper operation of doors.

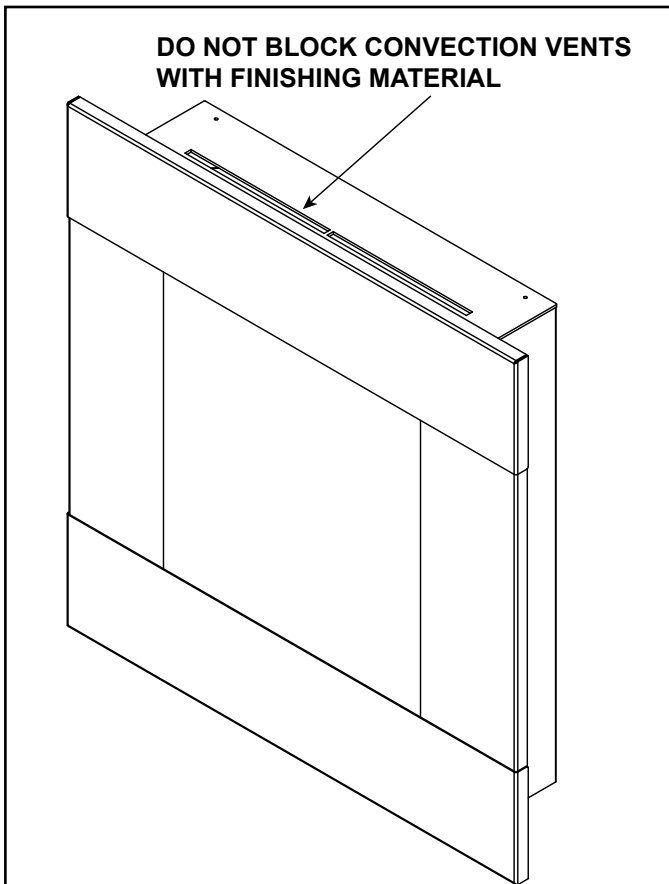

Figure 10.1 Convection Vent Location

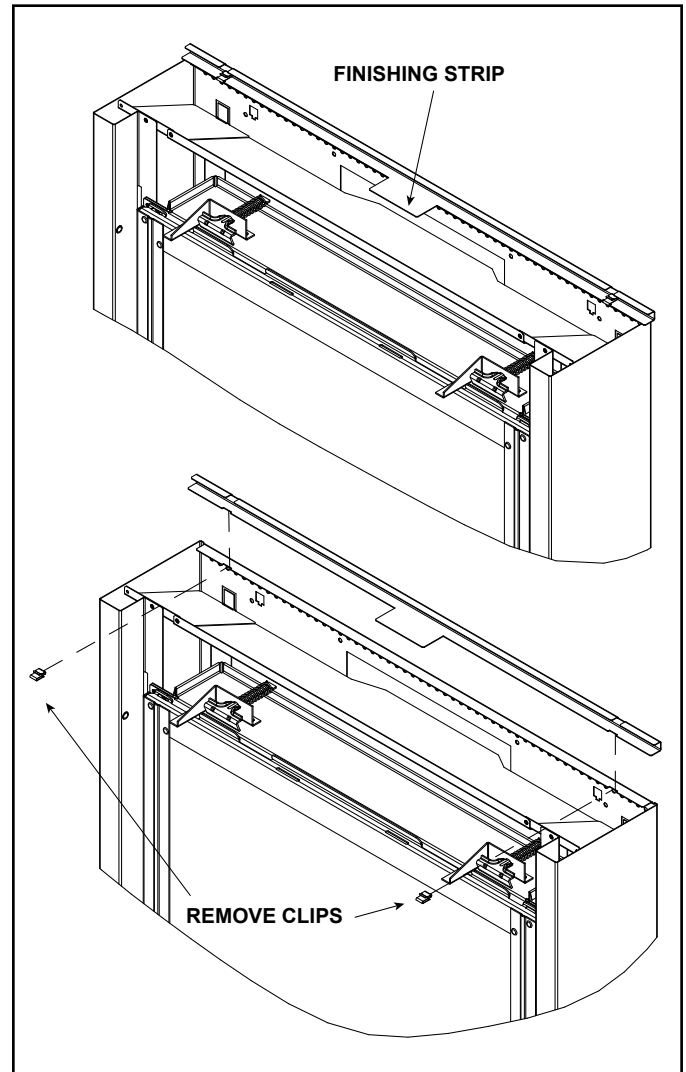
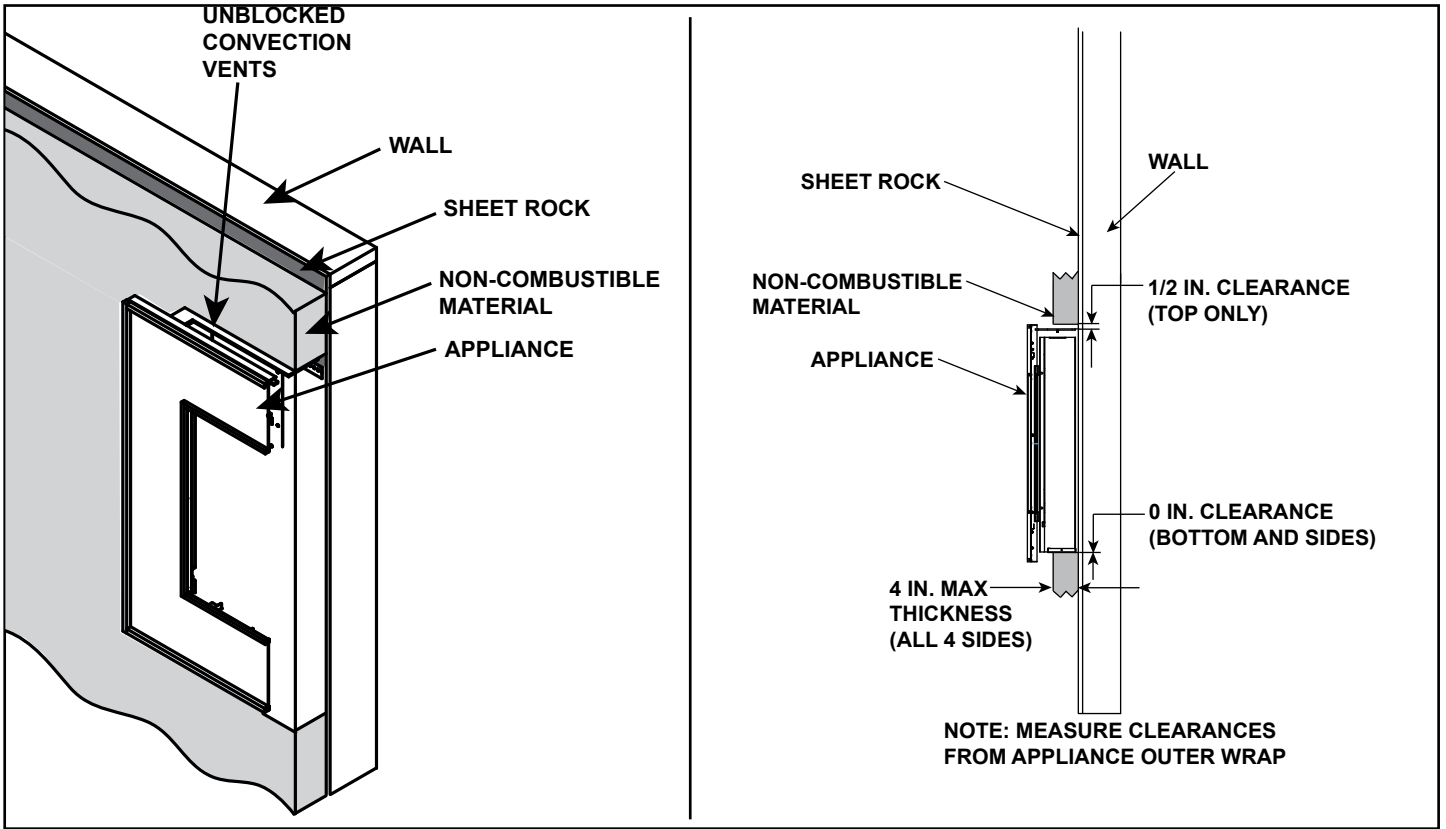

Figure 10.2 Remove Finishing Strip After Installation of Finishing Material ←



→ Figure 10.3 Non-Combustible Facing Diagram

C. Mantel Leg and Wall Projections

The mantel leg and wall projection dimensions are determined by the decorative front that is to be installed. Note the figure titles in regards to whether the mantel/wall projection is made from combustible or non-combustible material.

Combustible Mantel Legs or Wall Projections

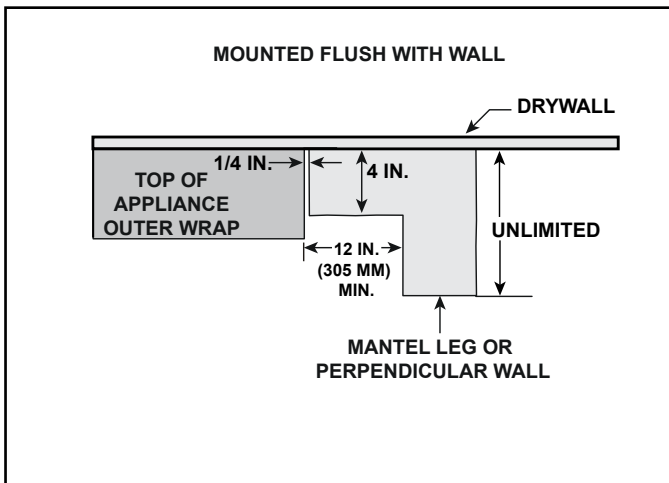

Figure 10.5 Combustible Mantel Leg or Wall Projections
(Acceptable on both sides of outer wrap)

Non-Combustible Mantel Legs or Wall Projections

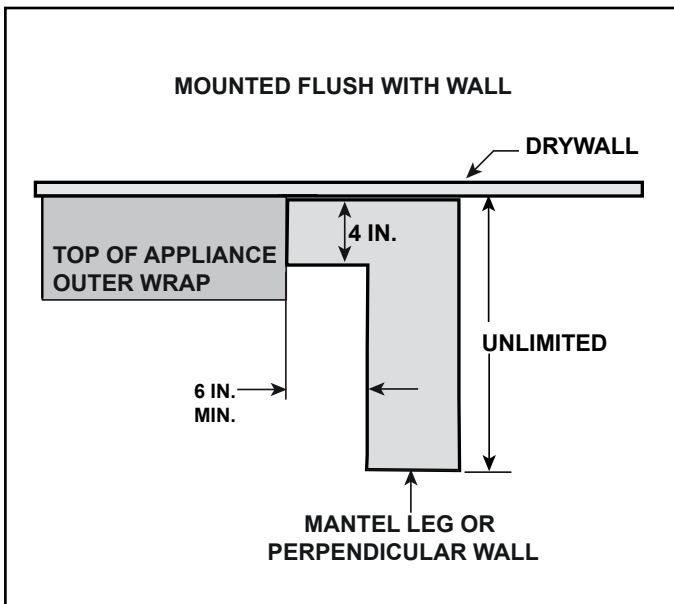

Figure 10.6 Non-Combustible Mantel Leg or Wall Projections
(Acceptable on both sides of outer wrap)

11 In-Wall Installation

The ION may be installed recessed into the wall using the In-Wall Tub.

A. Wall and Appliance Preparation

WARNING! Risk of Fire! Comply with all minimum clearances as specified. Framing closer than the minimums listed must be constructed entirely of noncombustible materials (i.e., steel studs, concrete board, etc.)

1. Prepare 2 in. x 6 in. framing as shown in Figure 11.1.

Note: 2 X 4 framing is not recommended in geographical regions that require an R-19 insulation value.

2. A Corrugated Template may be used to simplify the installation process. Contact your dealer or see Service Parts section in Owner's manual to order. Using the template for installations of the ION will help when locating the gas and electrical connections for the appliance. Install the corrugated template as shown in Figure 11.2. Use blocks to position the corrugated template in regards to depth.
3. Bring electrical and gas hookups to location designated by markings on corrugated template. Remove template and blocks when utility installation is complete.

Note: Hard-piped gas connections must be terminated with a specific "Z" dimension depth. See references to "Z" dimension in Figure 11.2. Terminating the Hard-piped gas connection with the proper "Z" dimension will simplify the process of connecting the gas to the appliance.

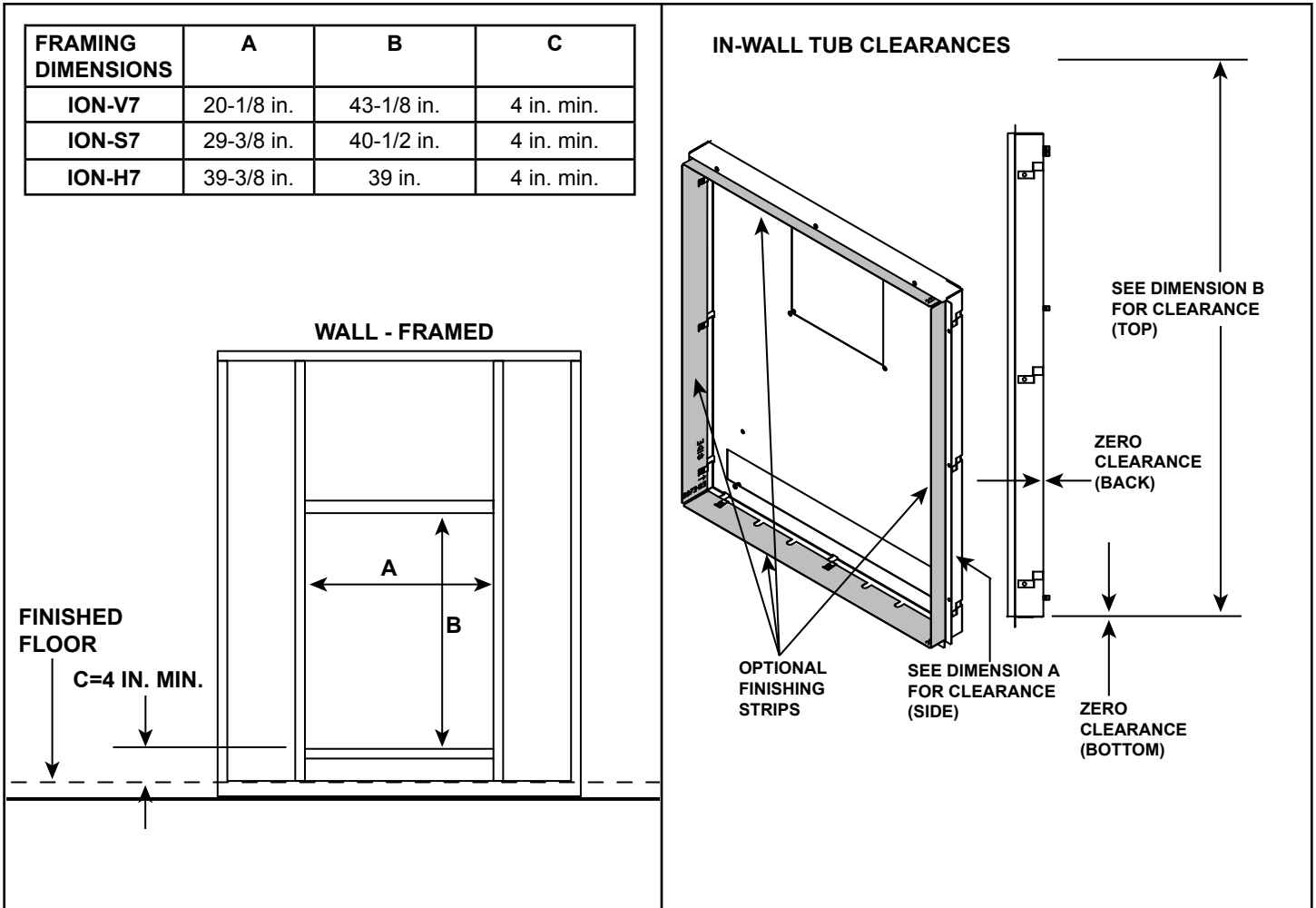

Figure 11.1 Framing Dimensions and In-Wall Tub - Clearances

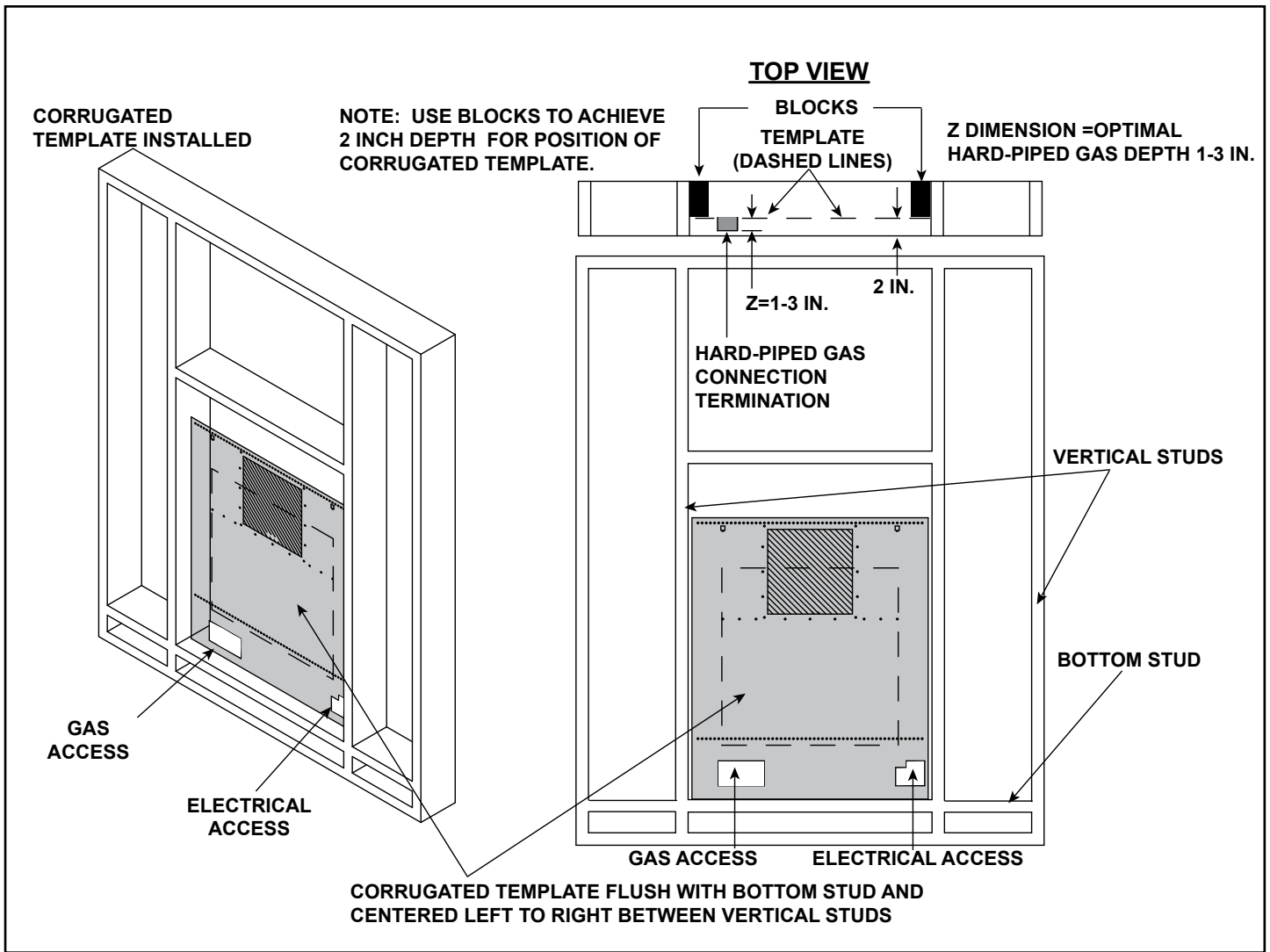

Figure 11.2 In-Wall with Corrugated Template

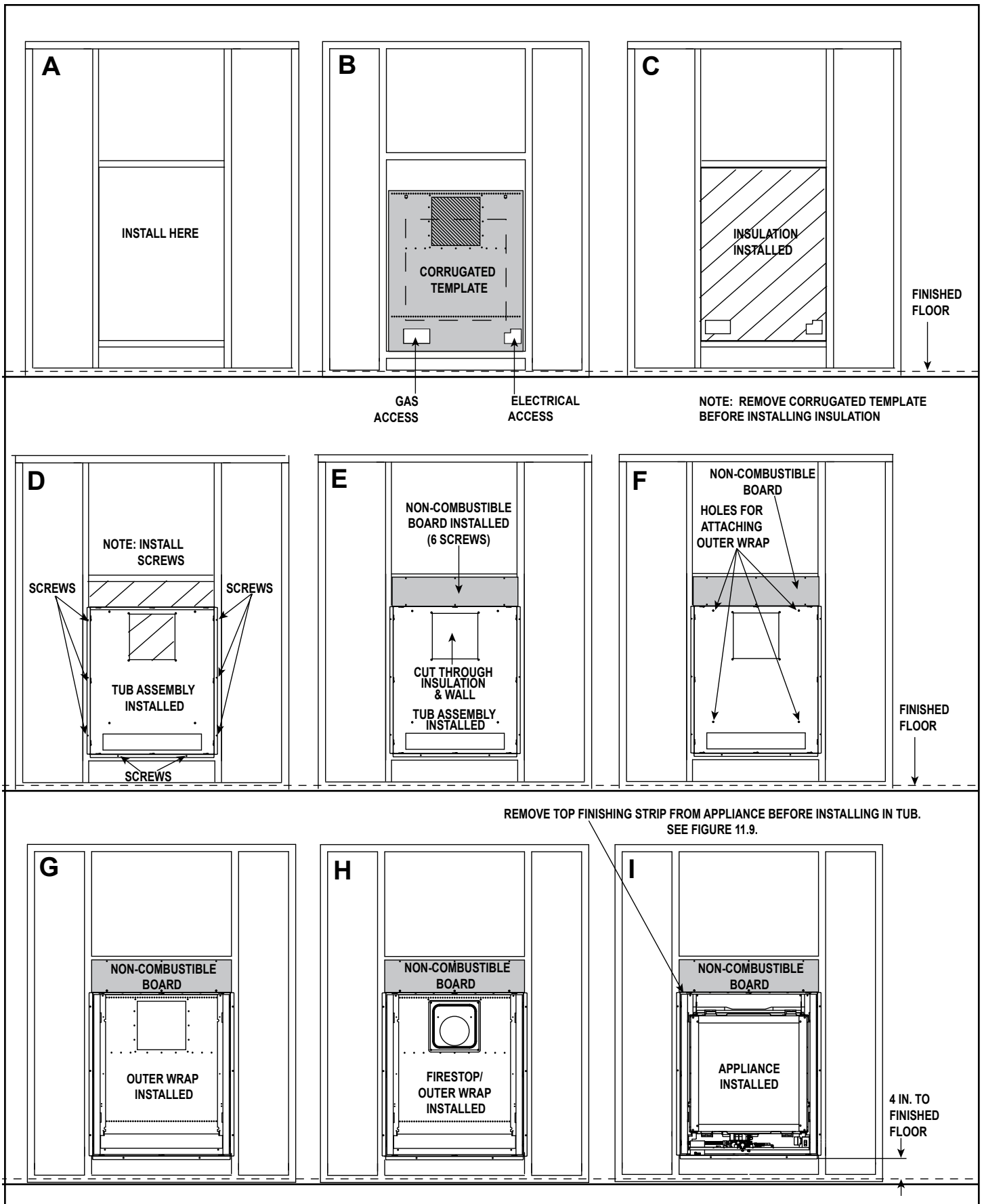

Figure 11.3. In-Wall Tub Installation

4. Insulate wall per local code requirements. Use Thermax where an R19 insulation value is required. See Figure 11.3 (C) and Figure 11.6.
5. Install In-Wall Tub as shown in Figure 11.3 (D). The tub should set on the framing. Verify hood clips are in the correct orientation. See Figure 11.5. Ensure tub is level. Use eight screws (supplied with In-Wall Kit) to attach the tub to the framing.

CAUTION! In-Wall Tub and Appliance Outer Wrap MUST be installed level for proper burner operation.

6. Install the required non-combustible board (supplied) as shown in Figure 11.3 (E) using six screws.

WARNING! Risk of Fire! DO NOT apply combustible materials beyond the minimum clearances. Comply with all minimum clearances to combustibles as specified in this instruction. Overlapping materials could ignite and will interfere with doors.

7. Cut through insulation and wall as shown in Figure 11.3(E). Allow space for clearance for the firestop framing discussed in step 11.
8. Remove the glass assembly from the firebox by releasing the two top glass latches and then the two bottom glass latches. See Figure 12.1.
9. Remove firebox from outer wrap. See Figure 6.8.
10. Install the outer wrap as shown in Figure 3 (F & G) using the four supplied bolts in the threaded holes. Additional screws may be installed to ensure the tub

- and the outer wrap are secured flat to one another.
11. Frame around the edges of the firestop cut out to ensure insulation does not come into contact with the vent pipe. See Figure 6.10 and 6.12.
12. Install firestop using the four supplied screws. See Figure 6.10 and 6.11. See Section 6.A for reference to sealing firestop.
13. Install finishing strips if applicable. See Figure 11.5.
14. Reattach firebox to outer wrap. Use Figure 6.8 and 6.13 for reference.
15. Replace the glass assembly on the appliance. Latch the two bottom glass assembly latches and then the two top glass latches. See Figure 12.1.
16. Attach the appliance vent system. See Section 6.A for reference to sealing firestop.

NOTICE! Install a cap extension if gap exists between the wall and the back of the termination cap. See Figure 11.4. An SLP-TRAP1 will generally be used with In-Wall installations.

17. Install vent and trap cap extension if a gap exists between the exterior wall and the cap. To prevent drafts, the cap extension should be sealed with caulk that has a minimum of 300°F continuous exposure rating to seal gaps of the extension. See Figure 11.4.

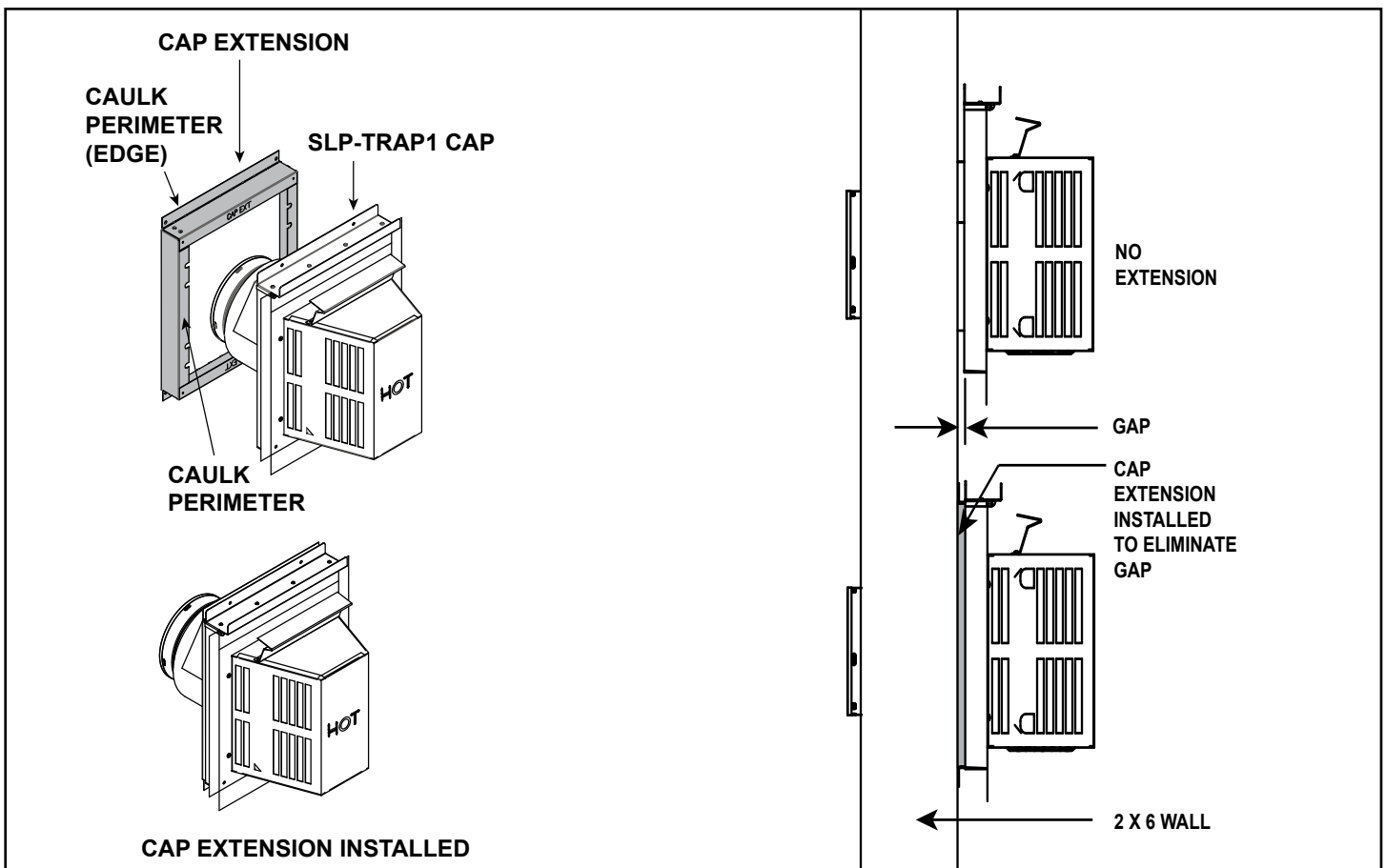

Figure 11.4 Cap Extension Installation

18. Have a qualified service technician make the connections to gas and electric service.

WARNING! Risk of Fire or Explosion! Gas and electric connections should be performed by a qualified service technician.

19. Gas line holes and other openings should be caulked or sealed.

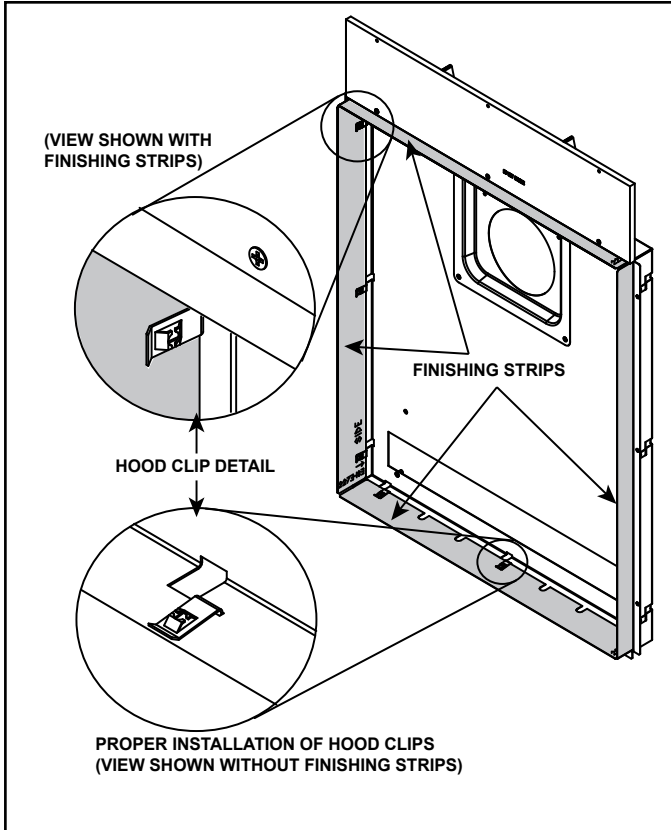

Figure 11.5 Finishing Strip Attachment & Proper Hood Clip Installation

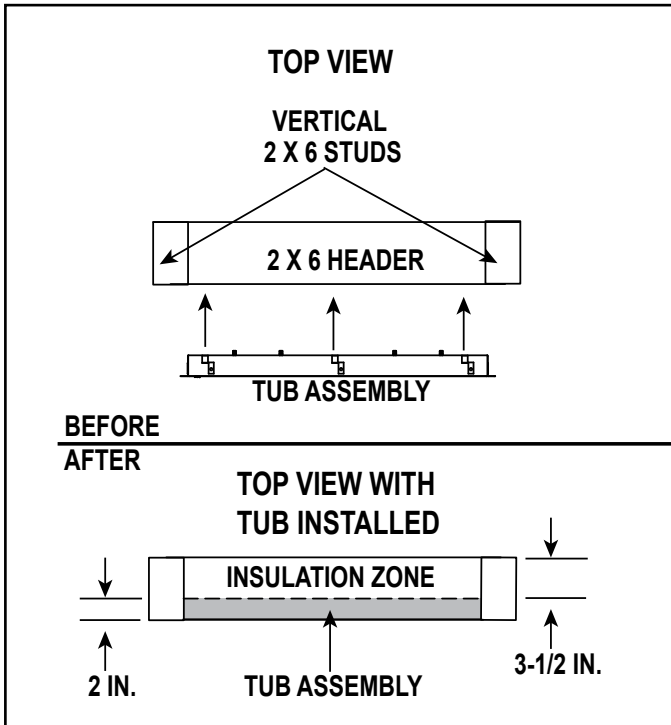

Figure 11.6. In-Wall Tub Installation - Top View

B. In-Wall - Minimum Combustible Facing Clearances

	A	D
ION-V7	20-1/8 in.	43-7/8 in.
ION-S7	29-3/8 in.	41-1/4 in.
ION-H7	39-3/8 in.	39-3/4 in.

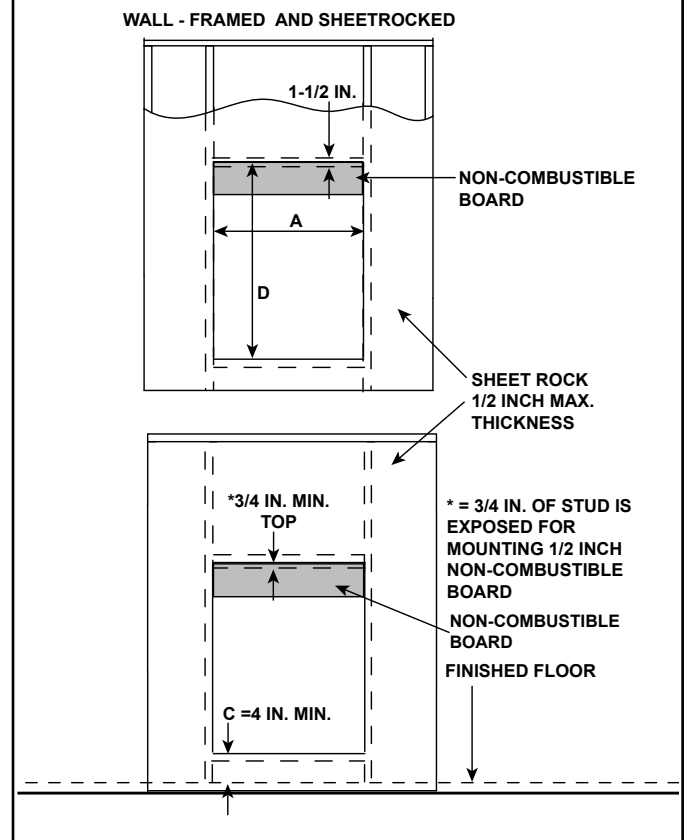

Figure 11.7. In-Wall Tub Installation - Sheet Rock Facing

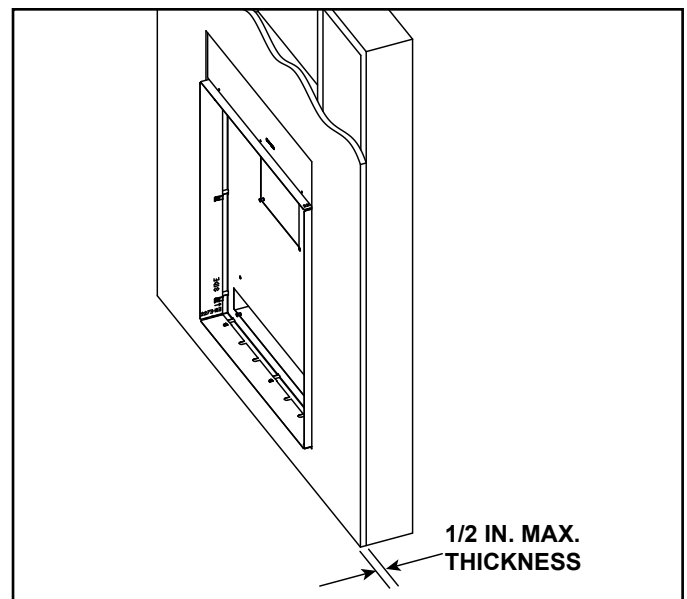
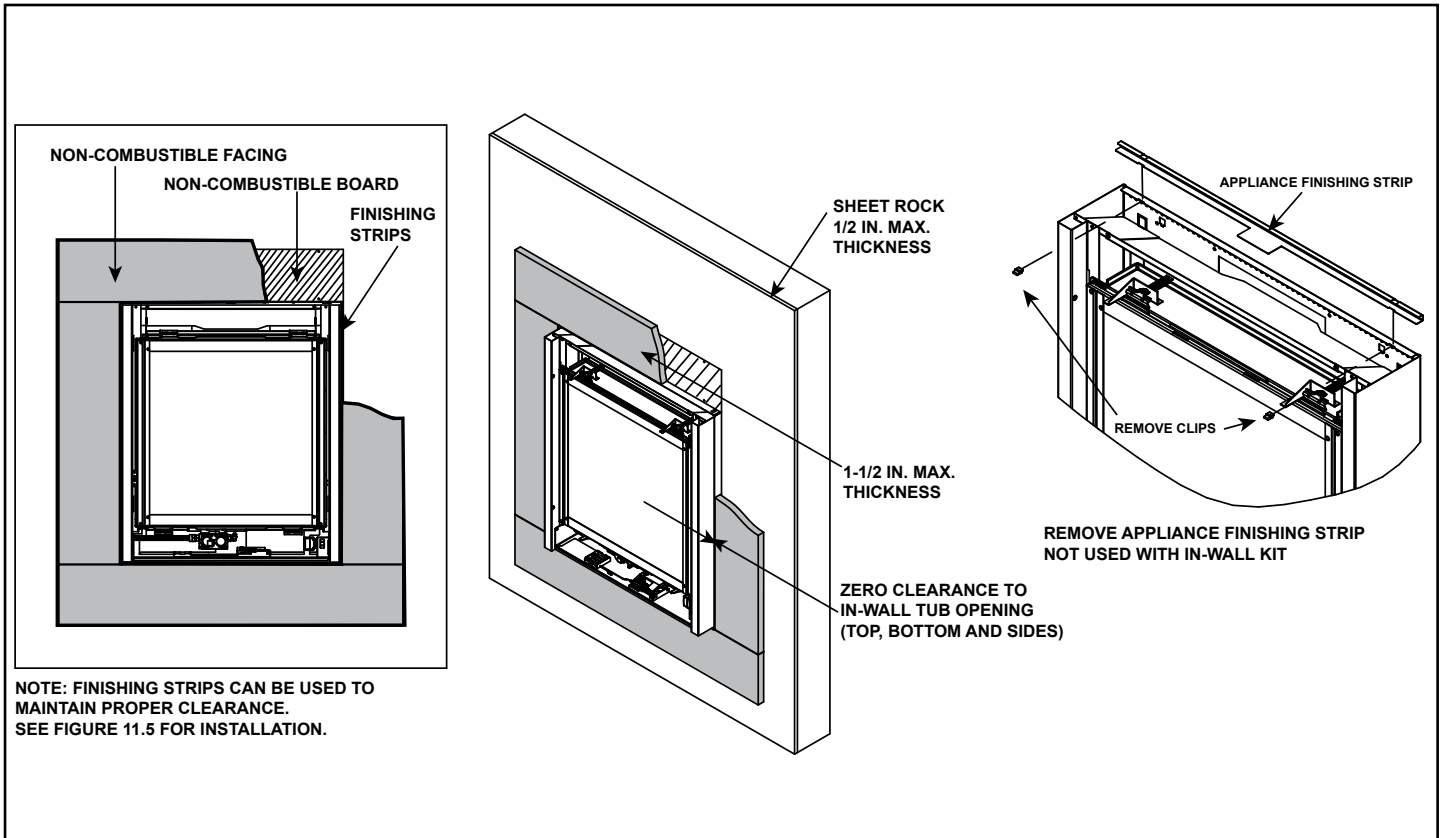

Figure 11.8. In-Wall Tub Installation - Sheet Rock Thickness

C. In-Wall - Minimum Non-Combustible Facing Clearances



→ Figure 11.9

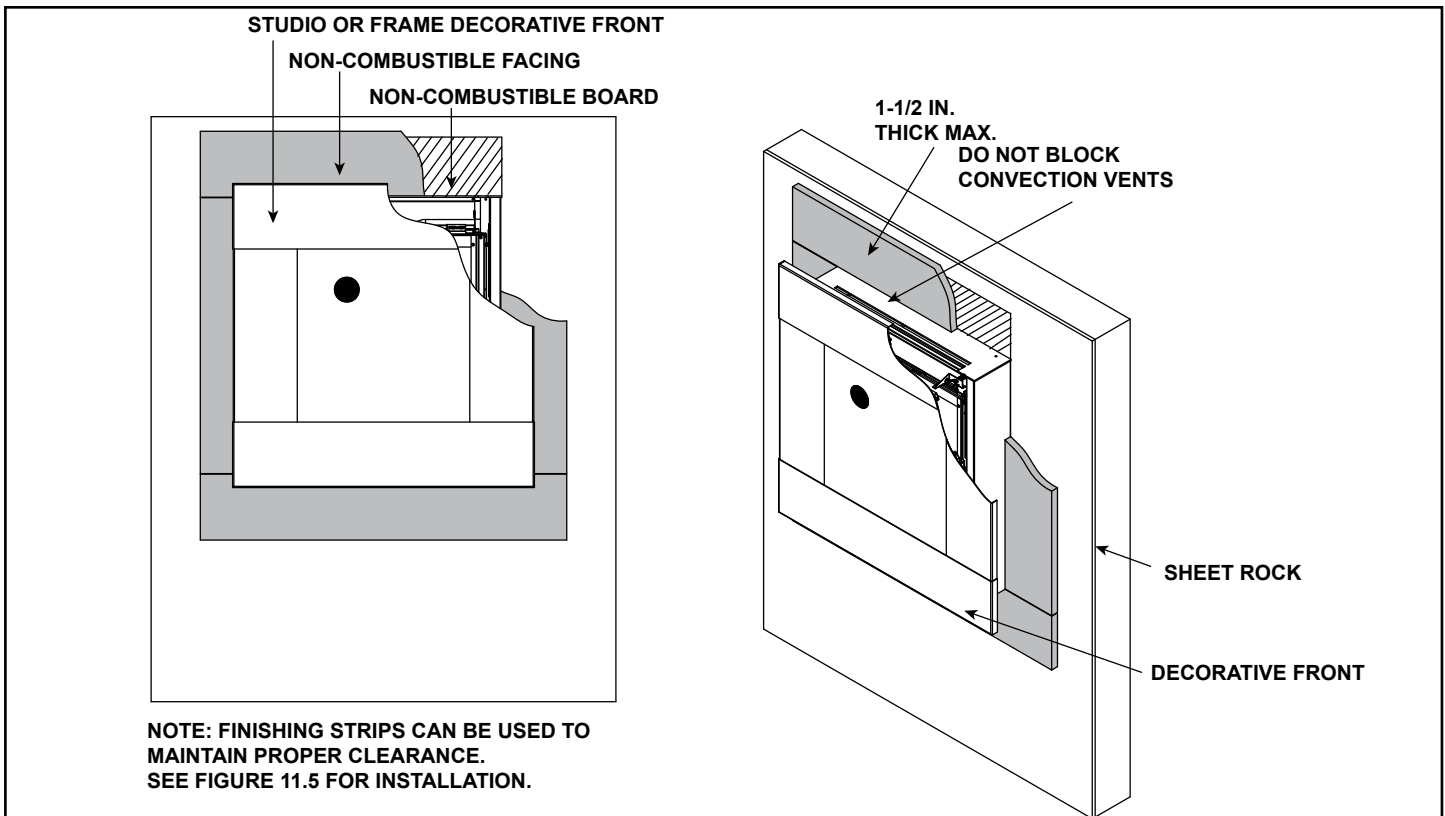

Figure 11.10

D. In-Wall Mantel and Wall Projections Combustible Mantel Legs or Wall Projections

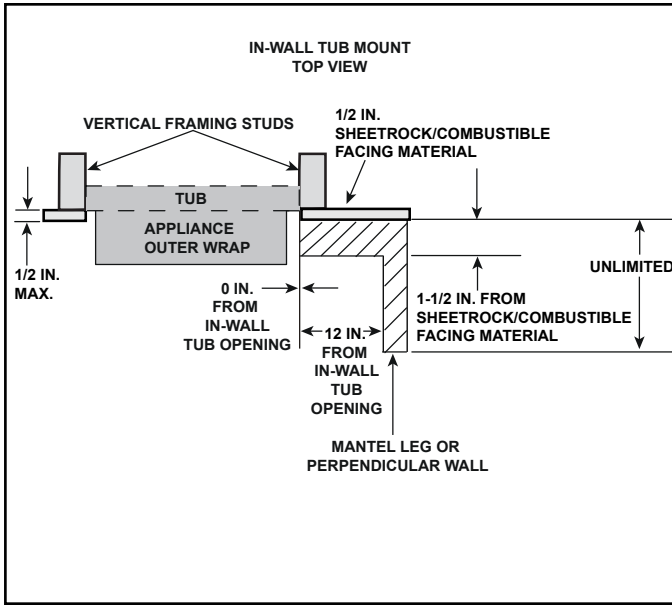

Figure 11.11 Combustible Mantel Leg or Wall Projections
(Acceptable on both sides of opening)

Non-Combustible Mantel Legs or Wall Projections

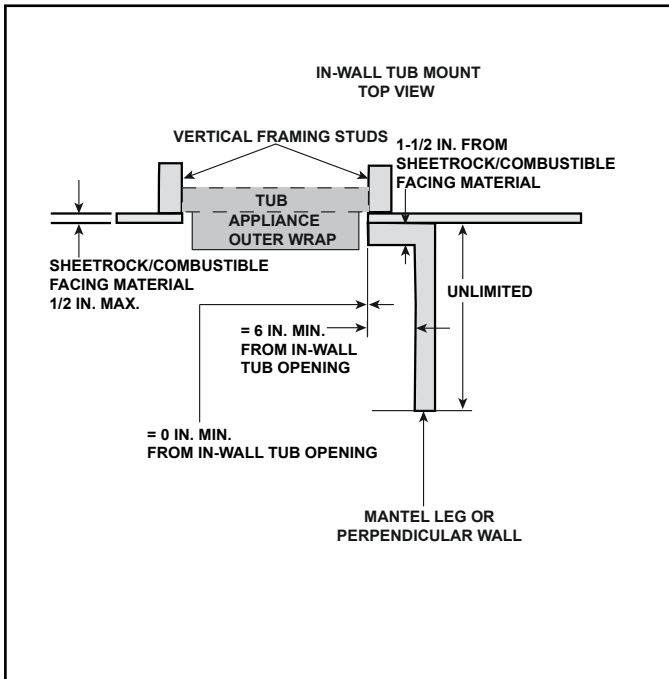

Figure 11.12 Non-Combustible Mantel Leg or Wall Projections
(Acceptable on both sides of opening)

Combustible Mantels Above Appliance Outer Wrap

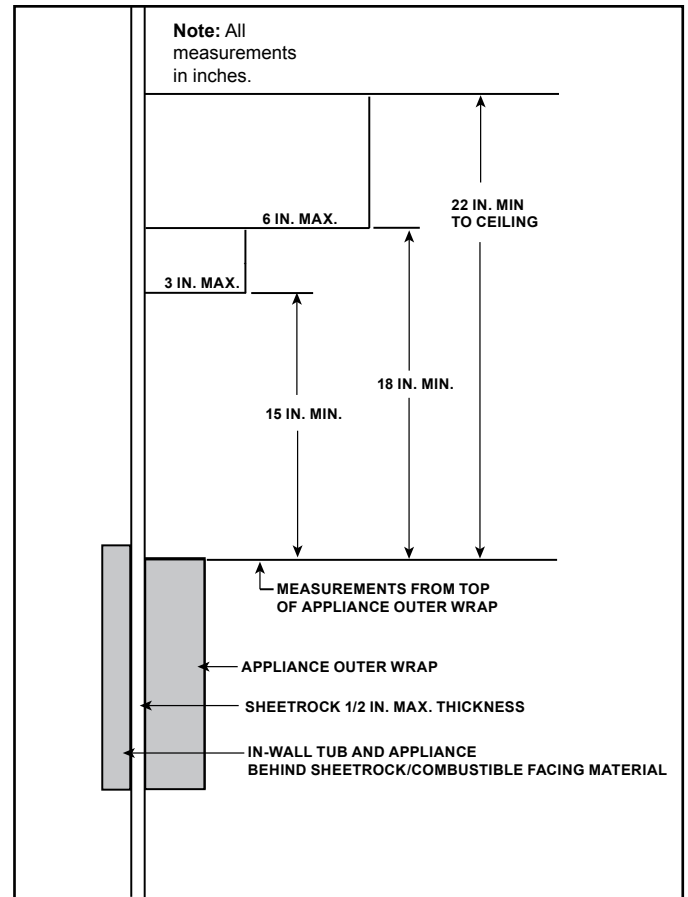

Figure 11.13 Minimum Vertical and Maximum Horizontal Dimensions of Combustibles

Non-Combustible Mantels Above Appliance Outer Wrap

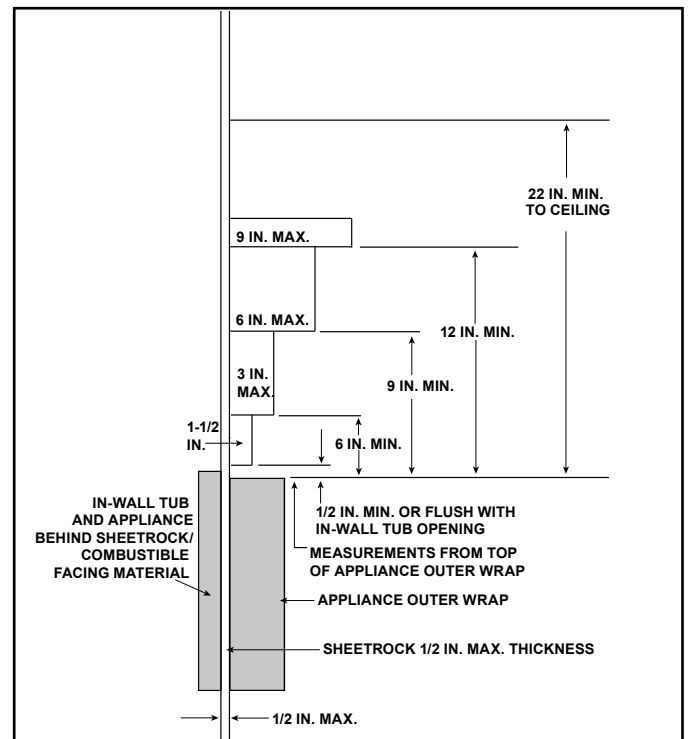

Figure 11.14 Minimum Vertical and Maximum Horizontal Dimensions of Non-Combustibles

E. In Wall - Finishing

The splatter guard is a piece of corrugated material used to protect the appliance during the installation process before finishing work on the whole hearth is complete. The splatter guard is shipped with the In-Wall Kit on the ION models. Splatter guards must be removed before appliance is fired.

WARNING! Risk of Fire! Close the ball valve before installing the splatter guard to prevent accidental lighting. Remove the splatter guard before lighting the appliance.

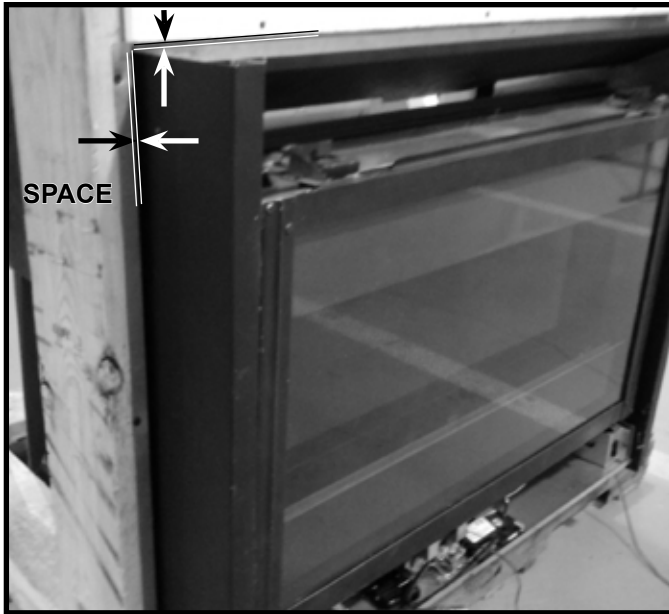

Figure 11.15 Splatter Guard Installation

1. Install the splatter guard in the space between the tub and the top and sides of the appliance outer wrap. See Figure 11.15.
2. To gain access to the component tray, lift the flap on the splatter guard and crease the perforation by hand. Bend the tabs and insert them into the slots on the splatter guard. See Figures 11.16 and 11.17.

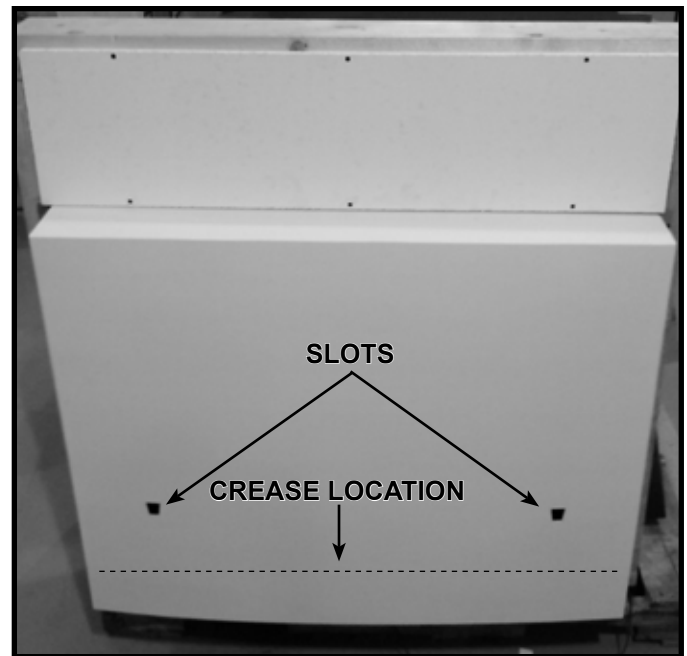

Figure 11.16 Splatter Guard Installed

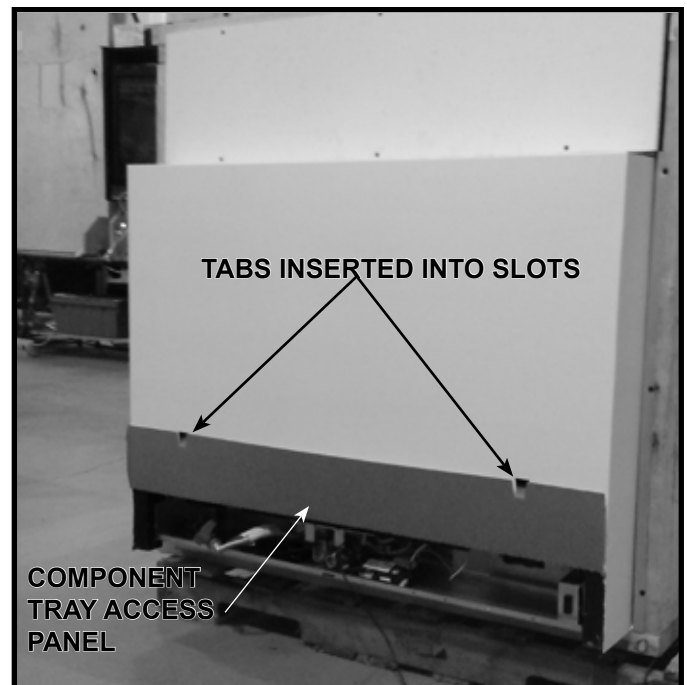

Figure 11.17 Component Tray Access

12 Appliance Setup

A. Removing Fixed Glass Assembly

WARNING! Risk of Asphyxiation! Handle fixed glass assembly with care. Inspect the gasket to ensure it is undamaged and inspect the glass for cracks, chips or scratches.

- **DO NOT** strike, slam or scratch glass.
- **DO NOT** operate fireplace with glass removed, cracked, broken or scratched.
- Replace as a complete assembly.

Removing Fixed Glass Assembly

- Remove the glass assembly from the firebox by releasing the two top glass latches and then the two bottom glass latches. Hold glass in place with one hand and disengage glass latches with the other hand. Remove glass assembly from the appliance. See Figure 12.1.

Replacing Fixed Glass Assembly

- Place the glass assembly on the appliance. Latch the two bottom glass assembly latches and then the two top glass latches. Hold glass in place with one hand and secure glass latches with the other hand. See Figure 12.1.

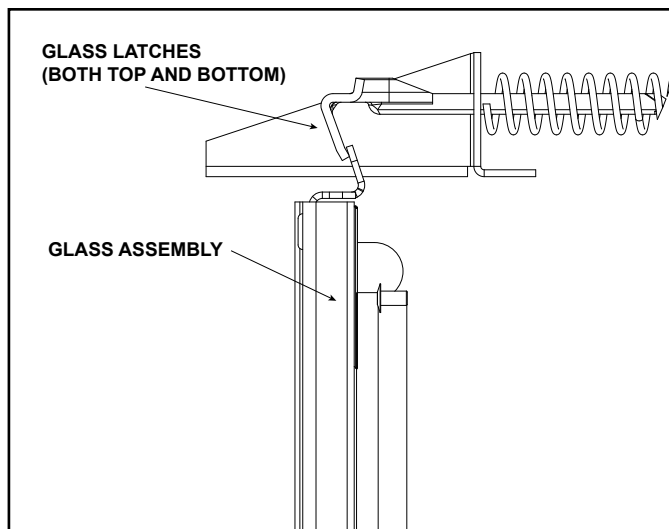

Figure 12.1 Fixed Glass Assembly

B. Remove the Shipping Materials

Remove shipping materials from inside or underneath the firebox. If an In-Wall kit has been purchased, a splatter guard will be included. The splatter guard is a piece of corrugated material used to protect the appliance during the installation process before finishing work on the whole hearth is complete. Splatter guards must be removed before appliance is fired. See Section 11.E for more information on installation of the splatter guard.

WARNING! Risk of Fire! Close the ball valve before installing the splatter guard to prevent accidental lighting. Remove the splatter guard before lighting the appliance.

Remove the glass shipping brackets by removing the two screws on each bracket. Discard glass shipping brackets. See Figure 12.2.

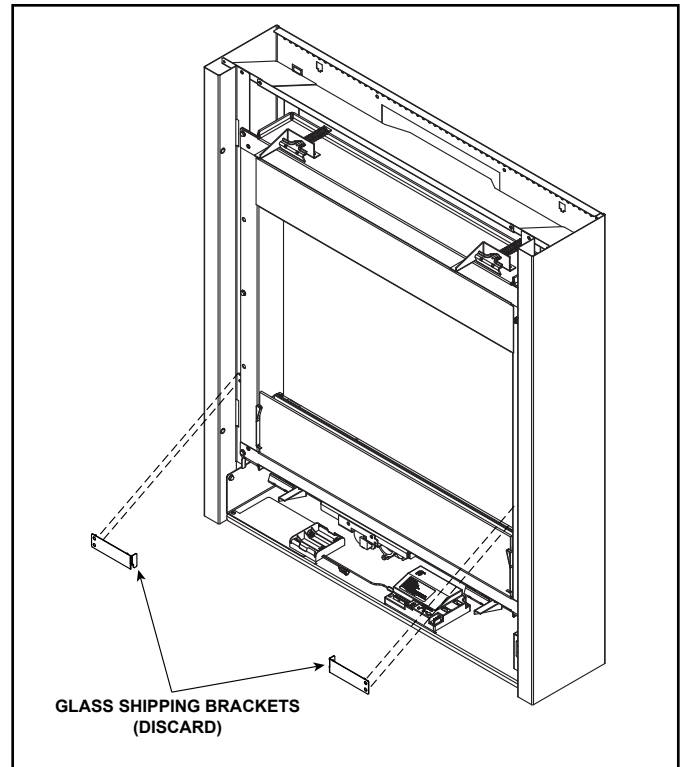

Figure 12.2 Remove Shipping Brackets

C. Clean the Appliance

Clean/vacuum any sawdust that may have accumulated inside the firebox or underneath in the control cavity.

D. Decorative Fronts/Mesh

The decorative fronts designed for this appliance include a mesh screen. Installation of the decorative front/mesh screen assembly is required for operation of this appliance. For installation instructions, see the instructions included with the decorative front.

WARNING! Risk of Fire! Install ONLY doors or fronts approved by Hearth & Home Technologies. Unapproved doors or fronts could cause fireplace to overheat.

This fireplace has been supplied with an integral barrier to prevent direct contact with the fixed glass panel. DO NOT operate the fireplace with the barrier removed.

Contact your dealer or Hearth & Home Technologies if the barrier is not present or help is needed to properly install one.

For more information refer to the instructions supplied with the decorative front.

13 Reference Materials

A. Vent Components Diagrams

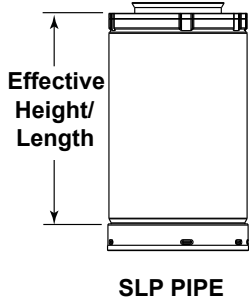
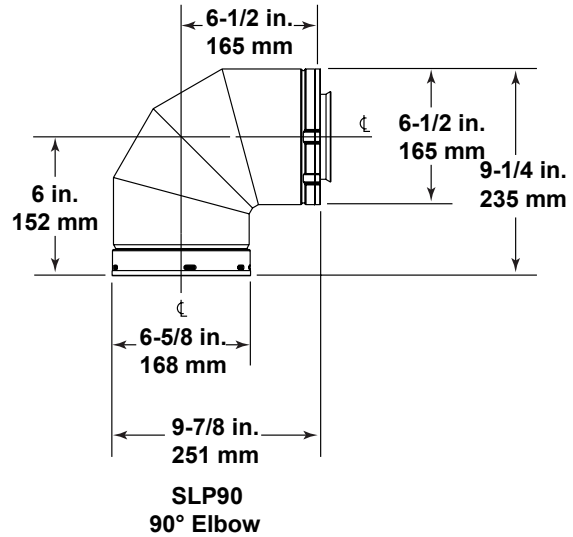
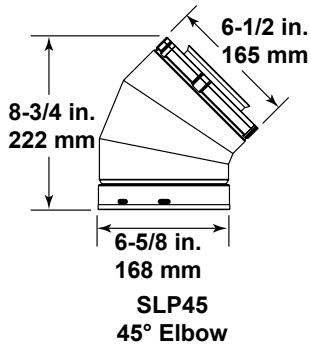

Effective Height/Length

Pipe	inches	mm
SLP4	4	102
SLP6	6	152
SLP12	12	305
SLP24	24	610
SLP36	36	914
SLP48	48	1219
SLP6A	2 - 6	51 - 152
SLP12A	2 - 12	51 - 305
SLP-FLEX-2	24	610
SLP-FLEX-3	36	914
SLP-FLEX-5	60	1524
SLP-FLEX-10	120	3048

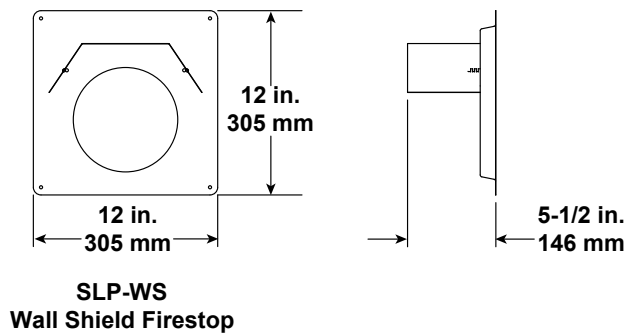
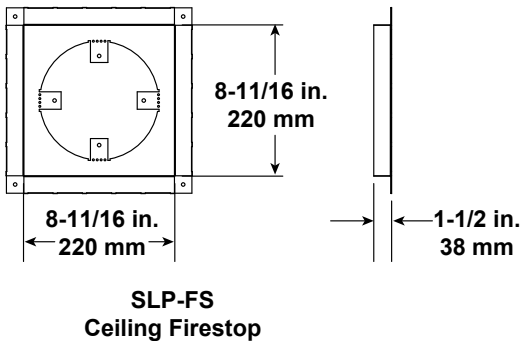
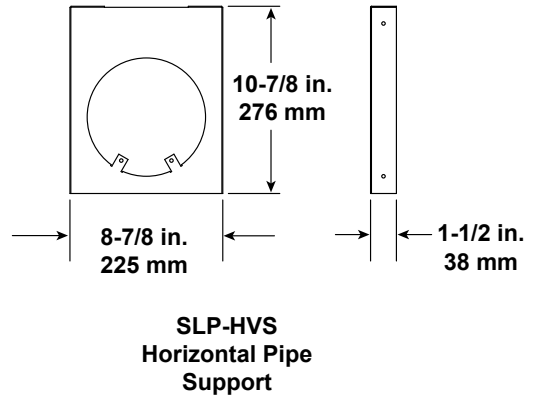
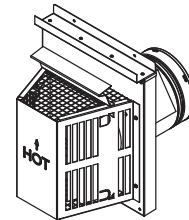
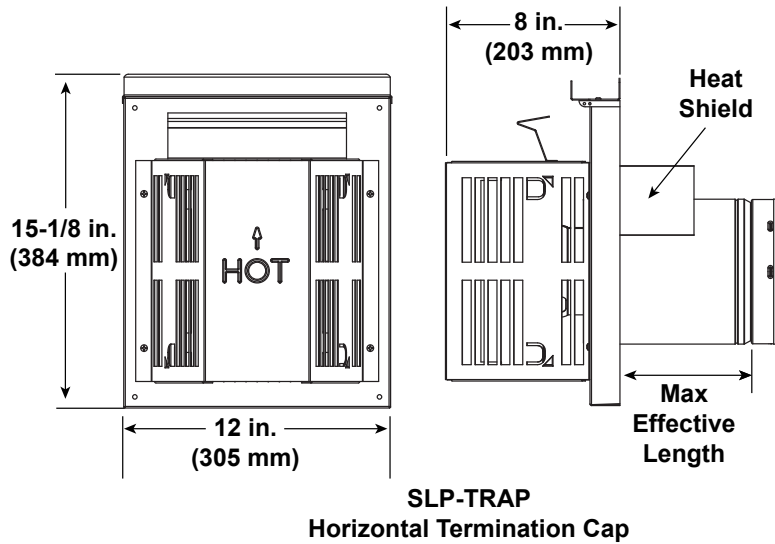

Figure 13.1 SLP Vent Components

A. Vent Components Diagrams (continued)

Note: Heat shields MUST overlap by a minimum of 1-1/2 in. (38 mm). The heat shield is designed to be used on a wall 4 in. to 7-1/4 in. (102 mm to 184 mm) thick. If wall thickness is less than 4 in. (102 mm) the existing heat shields must be field trimmed. If wall thickness is greater than 7-1/4 in. (184 mm) a DVP-HSM-B will be required.



Term Cap	Minimum Effective Length	Maximum Effective Length
Trap1	3-1/8 in.	4-3/4 in.
	79 mm	121 mm
Trap2	5-1/4 in.	9-1/4 in.
	133 mm	235 mm

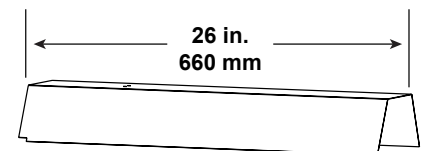
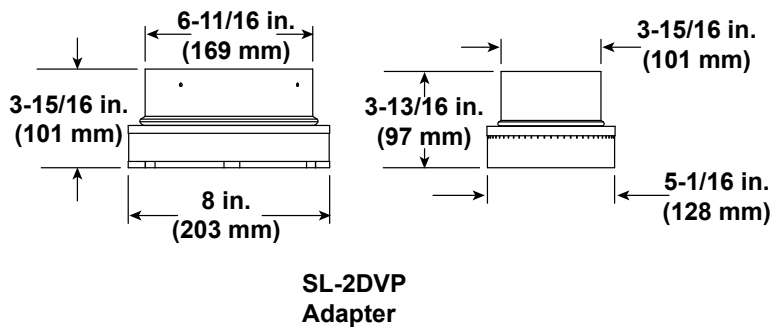

DVP-HSM-B
Extended Heat Shield

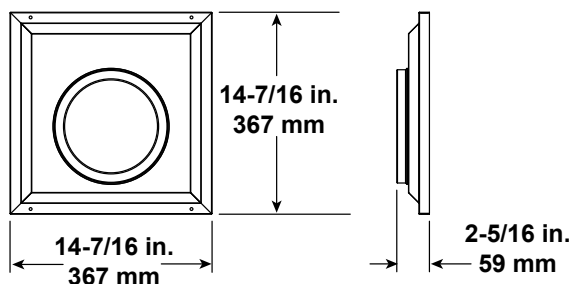
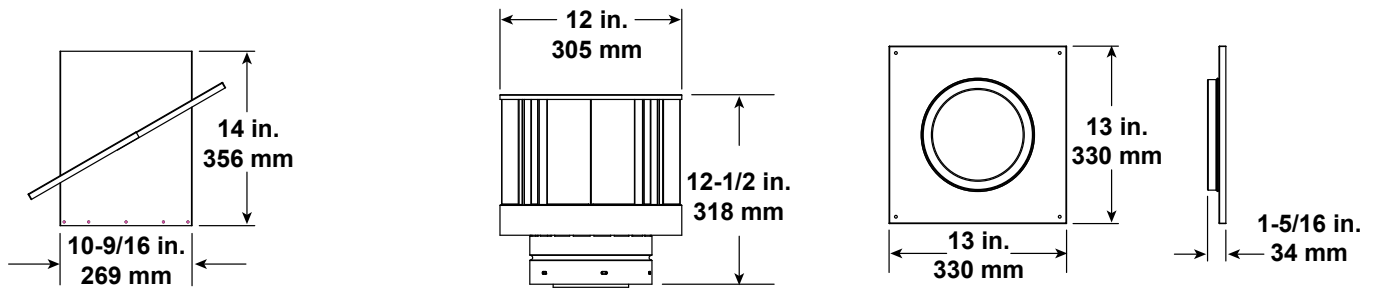

Figure 13.2 SLP vent components

A. Vent Components Diagrams (continued)



SLP-CCS-BK
Cathedral Ceiling
Support Box-Black

SLP-TVHW
Vertical
Termination Cap

SLP-DCF-BK
Ceiling Firestop
Black

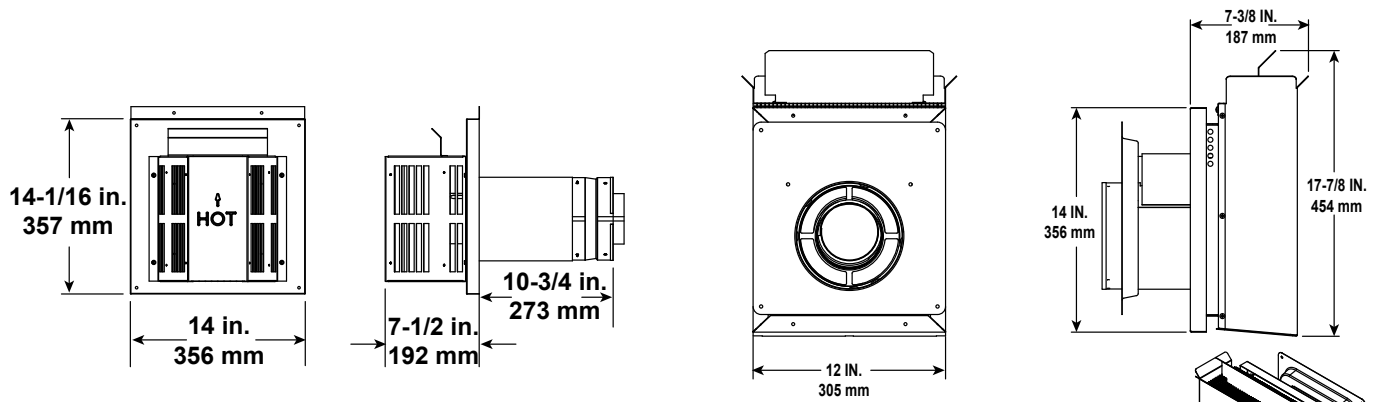

SLP-FLEX-TRAP
Horizontal
Termination Kit

SLP-TB1
Basement Vent Cap

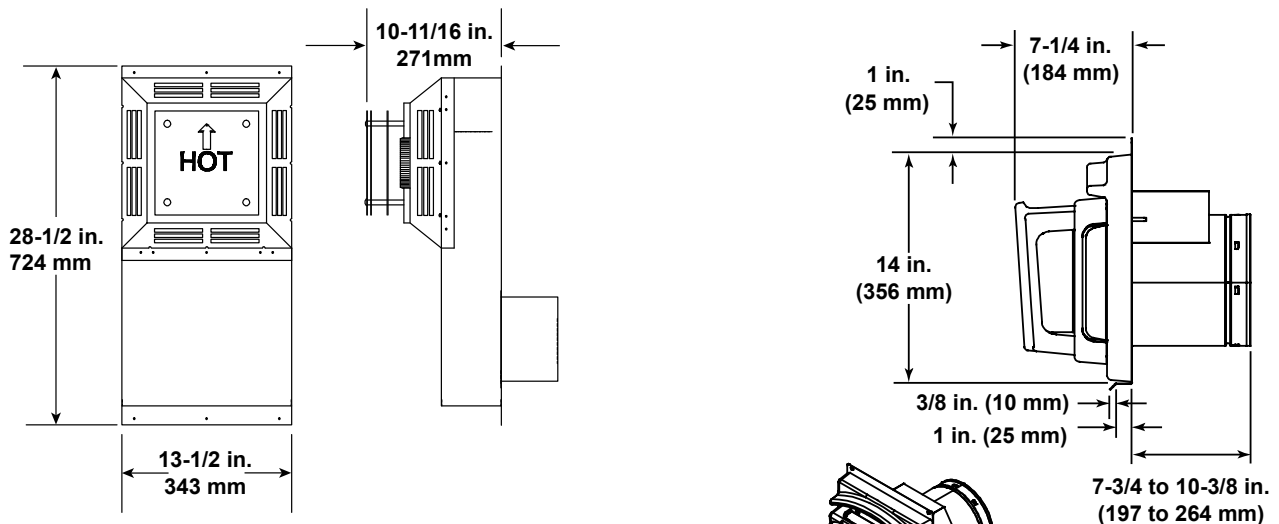

SLK-SNKD
Snorkel
Termination Cap

DVP-FBHT
Horizontal
Termination Cap

Figure 13.3 SLP vent components

A. Vent Components Diagrams (continued)

Note: Vent runs including the PVK-80 or PVI-SLP may not exceed 30 feet in total vent length or six 90 degree elbows.

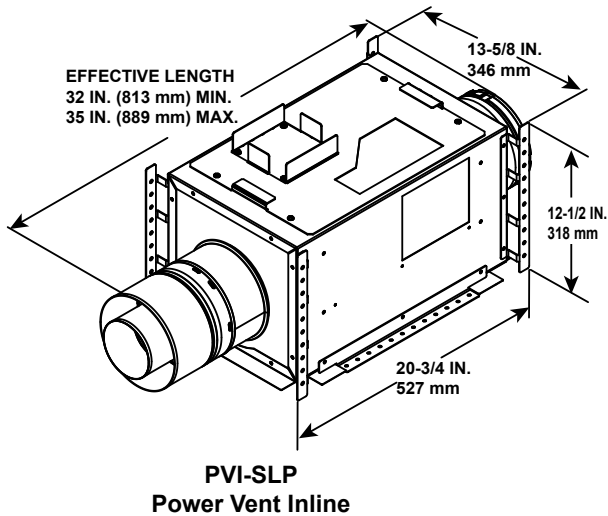

Optional Wire Harness	
DESCRIPTION	PART NUMBER
10 ft. PV Wire Harness	PVI-WH10
20 ft. PV Wire Harness	PVI-WH20
40 ft. PV Wire Harness	PVI-WH40
60 ft. PV Wire Harness	PVI-WH60
80 ft. PV Wire Harness	PVI-WH80
100 ft. PV Wire Harness	PVI-WH100

Note: Wire harnesses required to power the PVI-SLP connect to the appliance and are ordered separately from PVI-SLP. Contact your dealer to order.

Note: Use only approved termination caps with the PVI-SLP. See instructions included with PVI-SLP kit.

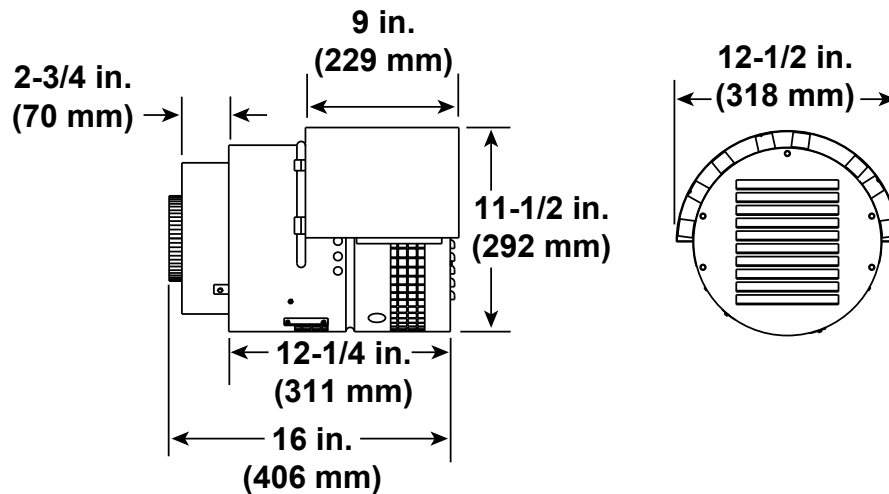

PVK-80

(Not approved for use with ION-V7.)

Figure 13.4 SLP vent components

B. Vent Components Diagrams (continued)

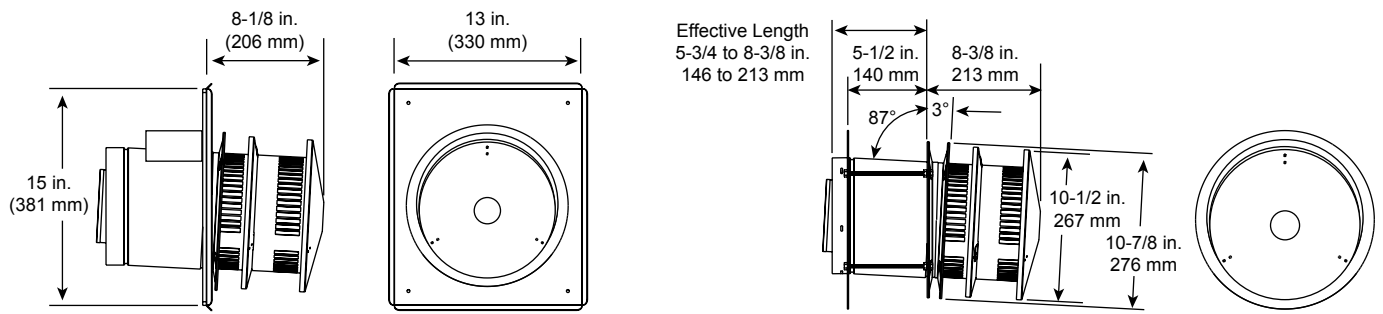

⚠ WARNING



Fire Risk.

- When using DVP-HRC-SS or DVP-HRC-ZC-SS termination caps on top vented fireplaces, a 6 inch minimum vertical vent section is required before installing first elbow.

**DVP-HRC-SS
DVP-HRC-ZC-SS
HORIZONTAL TERMINATION CAP**

COAXIAL to COLINEAR VENTING

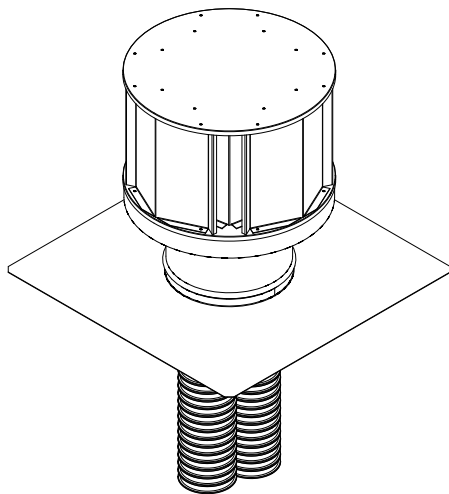

**LINK-DV30B
Flex Liner Kit**



**768-380A
Stainless Steel Flex Pipe**

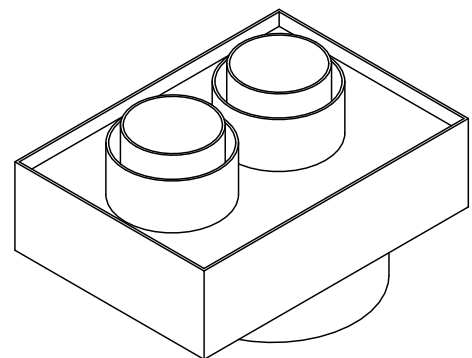

**DV-46DVA-GCL
Coaxial/Colinear Appliance Connector**

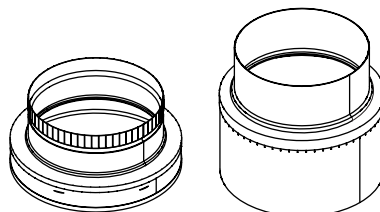

**DVP-2SL
Adapter**

Figure 13.5 DVP vent components

A. Vent Components Diagrams (continued)

PVLP-SLP
(Not approved for use with ION-V7)

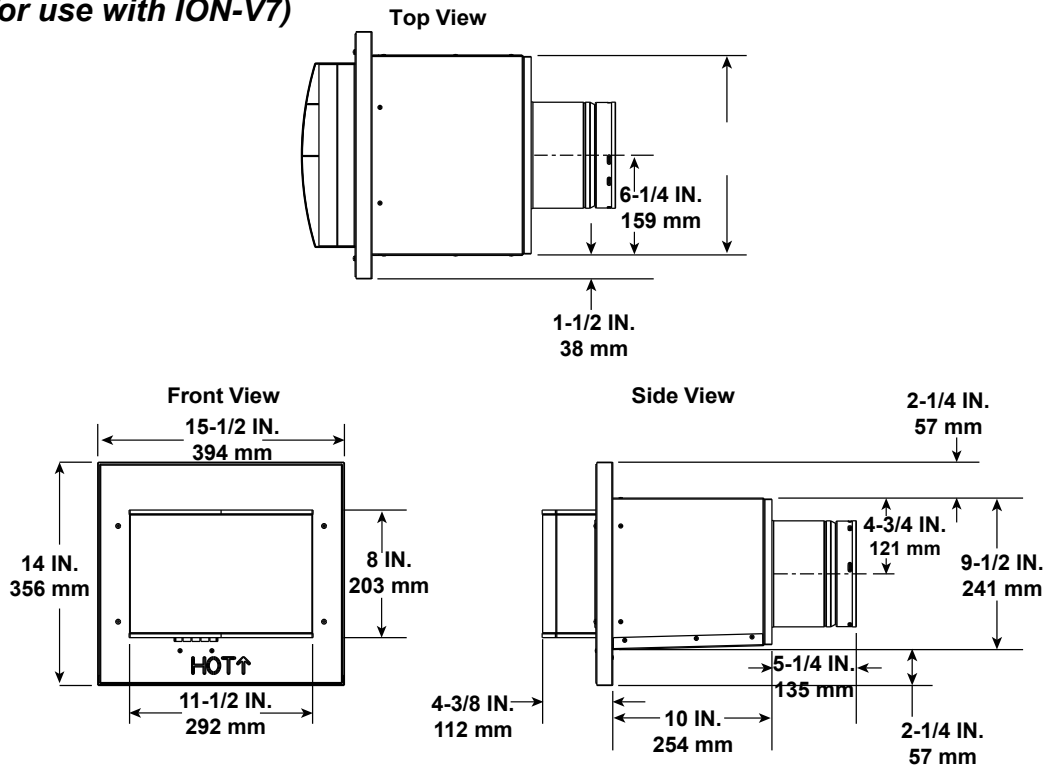

Required Wire Harness	
DESCRIPTION	PART NUMBER
10 FT PV Wire Harness	PVI-WH10
20 FT PV Wire Harness	PVI-WH20
40 FT PV Wire Harness	PVI-WH40
60 FT PV Wire Harness	PVI-WH60
80 FT PV Wire Harness	PVI-WH80
100 FT PV Wire Harness	PVI-WH100

Note: Wire harnesses required to power the PVLP-SLP connect to the appliance and are ordered separately from PVLP-SLP. Contact your dealer to order.

Note: The PVLP-SLP requires a PVLP-CK be installed on this appliance. The PVLP-CK is ordered separately from the PVLP-SLP. Contact your dealer to order.

Note: A PVLP-HS heat shield is available and sold separately. Use if the PVLP-SLP is installed in a high traffic area.

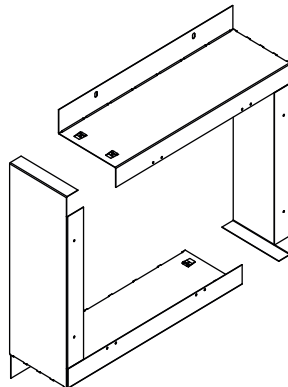

PVLP-BEK
 Brick Kit

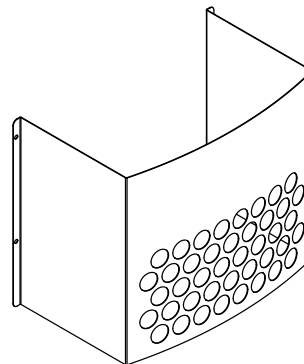

PVLP-HS
 Heat Shield

Figure 13.6 PVLP-SLP Vent Components

B. Accessories

Remote Controls, Wall Controls and Wall

Switches

Follow the instructions supplied with the control installed to operate your fireplace:

For safety:

- Install a switch lock or a wall/remote control with child protection lockout feature.
- Keep remote controls out of reach of children.

See your dealer if you have questions.

Heatilator, a brand of Hearth & Home Technologies
7571 215th Street West, Lakeville, MN 55044
www.heatilator.com

Please contact your Heatilator dealer with any questions or concerns.
For the location of your nearest Heatilator dealer,
please visit www.heatilator.com.

Printed in U.S.A. - Copyright 2015