

This appliance has been retired.
Service parts pages within have been removed.
For replacement parts, please refer to the individual
service parts list located on the brand websites.

HEAT & GLO™

No one builds a better fire

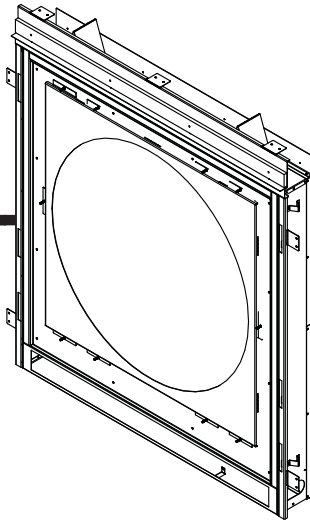

Owner's Manual Installation and Operation

Model:

SOLARIS36-ST

SOLARIS36-MR

GAS-FIRED



DO NOT DISCARD THIS MANUAL

- Important operating and maintenance instructions included.
- Read, understand and follow these instructions for safe installation and operation.
- Leave this manual with party responsible for use and operation.

**DO NOT
DISCARD**

⚠ WARNING:
FIRE OR EXPLOSION HAZARD
Failure to follow safety warnings exactly
could result in serious injury, death, or
property damage.

- **DO NOT** store or use gasoline or other flammable vapors and liquids in the vicinity of this or any other appliance.
- **What to do if you smell gas**
 - **DO NOT** try to light any appliance.
 - **DO NOT** touch any electrical switch. **DO NOT** use any phone in your building.
 - Leave the building immediately.
 - Immediately call your gas supplier from a neighbor's phone. Follow the gas supplier's instructions.
 - If you cannot reach your gas supplier, call the fire department.
- Installation and service must be performed by a qualified installer, service agency, or the gas supplier.

In the Commonwealth of Massachusetts installation must be performed by a licensed plumber or gas fitter.
See Table of Contents for location of additional Commonwealth of Massachusetts requirements.

DANGER



**HOT GLASS WILL
CAUSE BURNS.**

**DO NOT TOUCH GLASS
UNTIL COOLED.**

**NEVER ALLOW CHILDREN
TO TOUCH GLASS.**

A barrier designed to reduce the risk of burns from the hot viewing glass is provided with this appliance and shall be installed for the protection of children and other at-risk individuals.

This appliance may be installed as an OEM installation in manufactured home (USA only) or mobile home and must be installed in accordance with the manufacturer's instructions and the *Manufactured Home Construction and Safety Standard, Title 24 CFR, Part 3280* in the United States, or the *Standard for Installation in Mobile Homes, CAN/CSA Z240 MH Series*, in Canada.

This appliance is only for use with the type(s) of gas indicated on the rating plate. This appliance is not convertible for use with other gases, unless a certified kit is used.

Read this manual before installing or operating this appliance.
Please retain this owner's manual for future reference.

A. Congratulations

Congratulations on selecting a Heat & Glo gas fireplace, an elegant and clean alternative to wood burning fireplaces. The Heat & Glo gas fireplace you have selected is designed to provide the utmost in safety, reliability, and efficiency.

As the owner of a new fireplace, you'll want to read and carefully follow all of the instructions contained in this owner's manual. Pay special attention to all cautions and warnings.

This owner's manual should be retained for future reference. We suggest that you keep it with your other important documents and product manuals.

The information contained in this owner's manual, unless noted otherwise, applies to all models and gas control systems.

Your new Heat & Glo gas fireplace will give you years of durable use and trouble-free enjoyment. Welcome to the Heat & Glo family of fireplace products!

Homeowner Reference Information	<i>We recommend that you record the following pertinent information about your fireplace.</i>
Model Name: _____	Date purchased/installed: _____
Serial Number: _____	Location on fireplace: _____
Dealership purchased from: _____	Dealer Phone: _____
Notes: _____	

Listing Label Information/Location

The model information regarding your specific fireplace can be found on the rating plate usually located in the control area of the fireplace.



No one builds a better fire

Heat & Glo, a brand of Hearth & Home Technologies
7571 215th Street West, Lakeville, MN 55044

GAS-FIRED
UL
LISTED

Not for use with solid fuel.
(Ne doit pas être utilisé avec un combustible solide).

Type of Gas (Sorte De Gaz): **NATURAL GAS** This appliance must be installed in accordance with local codes, if any; if not, follow ANSI Z223.1 in the USA or CAN/CGA B149 installation codes. *(Installer l'appareil selon les codes ou règlements locaux ou, en l'absence de tels règlements, selon les codes d'installation CAN/CGA-B149.)*

ANSI Z21XX-XXXX · CSA 2.XX-MXX

Minimum Permissible Gas Supply for Purposes of Input Adjustment.

Approved Minimum (De Gaz) Acceptable	0.0 in w.c.	(Po. Col. d'eau)
Maximum Pressure (Pression)	0.0 in w.c.	(Po. Col. d'eau)
Maximum Manifold Pressure (Pression)	0.0 in w.c.	(Po. Col. d'eau)
Minimum Manifold Pressure (Pression)	0.0 in w.c.	(Po. Col. d'eau)

Total Electrical Requirements: 000Vac, 00Hz., less than 00 Amperes

MADE IN USA

ALTITUDE:	0-0000 FT. 0000-0000FT.	IN CANADA
MAX. INPUT BTUH:	00,000 00,000	
MIN. INPUT BTUH:	00,000 00,000	
ORIFICE SIZE:	#XXXXX #XXXXX	

Model:
(Modele): XXXXXXXX

Serial
(Serie): XXXXXXXX

Model Number

Serial Number

▲ Safety Alert Key:

- **DANGER!** Indicates a hazardous situation which, if not avoided will result in death or serious injury.
- **WARNING!** Indicates a hazardous situation which, if not avoided could result in death or serious injury.
- **CAUTION!** Indicates a hazardous situation which, if not avoided, could result in minor or moderate injury.
- **NOTICE:** Used to address practices not related to personal injury.

Table of Contents

A. Congratulations	2
→ B. Limited Lifetime Warranty	5

1 Listing and Code Approvals

A. Appliance Certification	7
B. Glass Specifications	7
C. BTU Specifications	7
D. High Altitude Installations	7
E. Non-Combustible Materials Specification	7
F. Combustible Materials Specification	7
G. Electrical Codes	7
H. Requirements for the Commonwealth of Massachusetts	8

User Guide

2 Operating Instructions

A. Gas Fireplace Safety	9
B. Your Fireplace	9
C. Clear Space	10
D. Decorative Fronts	10
E. Fixed Glass Assembly	10
F. Remote Control, Wall Controls and Wall Switches	10
G. Before Lighting Fireplace	10
H. Lighting Instructions (PVI-SLP-B)	10
I. After Fireplace is Lit	12
J. Frequently Asked Questions	12

3 Maintenance and Service

A. Maintenance Tasks-Homeowner	13
B. Maintenance Tasks-Qualified Service Technician	13

Installer Guide

4 Getting Started

A. Typical Appliance System	16
B. Design and Installation Considerations	17
C. Tools and Supplies Needed	17
D. Inspect Appliance and Components	17

5 Framing and Clearances

A. Selecting Appliance Location	18
B. Constructing the Appliance Chase	19
C. Clearances	19
D. Mantel and Wall Projections	20

6 Termination Locations

A. Vent Termination Minimum Clearances	22
--	----

7 Vent Information and Diagrams

A. Approved Pipe	24
B. Vent Table Key	24
C. Use of Elbows	24
D. Measuring Standards	24
E. Vent Diagrams	25

8 Vent Clearances and Framing

A. Pipe Clearances to Combustibles	31
B. Wall Penetration Framing	31
C. Install PVI-SLP-B	32
D. Install the Ceiling Firestop	37
E. Install Attic Insulation Shield	39

9 Appliance Preparation

A. Securing and Leveling Appliance	40
--	----

10 Installing Vent Pipe (DVRP and SLP Pipe) and PVI-SLP-B

A. Assemble Vent Sections (DVRP Pipe Only)	41
B. Assemble Vent Sections (SLP Pipe Only)	42
C. Assemble Slip Sections	42
D. Installation of the PVI-SLP-B Power Vent	43
E. Secure the Vent Sections	43
F. Disassemble Vent Sections	43
G. Install Decorative Ceiling Components (SLP only)	44
H. Install Metal Roof Flashing	45
I. Assemble and Install Storm Collar	45
J. Install Vertical Termination Cap	46
K. Install Decorative Wall Components (SLP only)	46
L. Heat Shield Requirements for Horizontal Termination	46
M. Install Horizontal Termination Cap (DVP and SLP Pipe)	47

11 Gas Information

A. Fuel Conversion	48
B. Gas Pressure	48
C. Gas Connection	48
D. High Altitude Installations	48

12 Electrical Information

A. Wiring Requirements	49
B. Wall Switch Installation	49
C. IntelliFire™ Plus Ignition System Wiring	49
D. Optional Accessories Requirements	49
E. Electrical Service and Repair	51
F. Junction Box Installation	51
G. PVI-SLP-B Wiring	52

13 Finishing

A. Doors and Finishing - Front Side	53
B. Doors and Finishing - Back Side	55
C. Doors and Finishing - Both Sides.	56

14 Appliance Setup

A. Fixed Glass Assembly	57
B. Remove the Shipping Materials	57
C. Clean the Appliance	57
D. Install Framed Mesh/Decorative Front	57
E. Install LED's	58
F. Air Shutter Setting	58
G. PVI-SLP-B Operation	59

15 Troubleshooting

A. IntelliFire™ Plus Ignition System	61
B. PVI-SLP-B Troubleshooting	63

16 Reference Materials

A. Appliance Dimension Diagram	64
B. Vent Components Diagrams	65
→ C. Service Parts	69
D. Contact Information	73

→ = Contains updated information.

→ **B. Limited Lifetime Warranty**

**Hearth & Home Technologies
LIMITED LIFETIME WARRANTY**

Hearth & Home Technologies, on behalf of its hearth brands (“HHT”), extends the following warranty for HHT gas, wood, pellet, coal and electric hearth appliances that are purchased from an HHT authorized dealer.

WARRANTY COVERAGE:

HHT warrants to the original owner of the HHT appliance at the site of installation, and to any transferee taking ownership of the appliance at the site of installation within two years following the date of original purchase, that the HHT appliance will be free from defects in materials and workmanship at the time of manufacture. After installation, if covered components manufactured by HHT are found to be defective in materials or workmanship during the applicable warranty period, HHT will, at its option, repair or replace the covered components. HHT, at its own discretion, may fully discharge all of its obligations under such warranties by replacing the product itself or refunding the verified purchase price of the product itself. The maximum amount recoverable under this warranty is limited to the purchase price of the product. This warranty is subject to conditions, exclusions and limitations as described below.

WARRANTY PERIOD:

Warranty coverage begins on the date of original purchase. In the case of new home construction, warranty coverage begins on the date of first occupancy of the dwelling or six months after the sale of the product by an independent, authorized HHT dealer/ distributor, whichever occurs earlier. The warranty shall commence no later than 24 months following the date of product shipment from HHT, regardless of the installation or occupancy date. The warranty period for parts and labor for covered components is produced in the following table.

The term “Limited Lifetime” in the table below is defined as: 20 years from the beginning date of warranty coverage for gas appliances, and 10 years from the beginning date of warranty coverage for wood, pellet, and coal appliances. These time periods reflect the minimum expected useful lives of the designated components under normal operating conditions.

Warranty Period		HHT Manufactured Appliances and Venting							Components Covered
Parts	Labor	Gas	Wood	Pellet	EPA Wood	Coal	Electric	Venting	
1 Year		X	X	X	X	X	X	X	All parts and material except as covered by Conditions, Exclusions, and Limitations listed
2 years				X	X	X			Igniters, electronic components, and glass
		X	X	X	X	X			Factory-installed blowers
		X	X						Molded refractory panels
3 years				X					Ignition Modules
5 years	1 year			X	X				Firepots and burnpots
7 years	3 years		X	X	X				Castings and baffles
10 years	1 year	X							Manifold tubes, HHT chimney and termination
Limited Lifetime	3 years	X	X	X	X	X			Burners, logs and refractory
90 Days		X	X	X	X	X	X	X	Firebox and heat exchanger
									All replacement parts beyond warranty period

See conditions, exclusions, and limitations on next page.

→ B. Limited Lifetime Warranty (*continued*)

WARRANTY CONDITIONS:

- This warranty only covers HHT appliances that are purchased through an HHT authorized dealer or distributor. A list of HHT authorized dealers is available on the HHT branded websites.
- This warranty is only valid while the HHT appliance remains at the site of original installation.
- This warranty is only valid in the country in which the HHT authorized dealer or distributor that sold the appliance resides.
- Contact your installing dealer for warranty service. If the installing dealer is unable to provide necessary parts, contact the nearest HHT authorized dealer or supplier. Additional service fees may apply if you are seeking warranty service from a dealer other than the dealer from whom you originally purchased the product.
- Check with your dealer in advance for any costs to you when arranging a warranty call. Travel and shipping charges for parts are not covered by this warranty.

WARRANTY EXCLUSIONS:

This warranty does not cover the following:

- Changes in surface finishes as a result of normal use. As a heating appliance, some changes in color of interior and exterior surface finishes may occur. This is not a flaw and is not covered under warranty.
- Damage to printed, plated, or enameled surfaces caused by fingerprints, accidents, misuse, scratches, melted items, or other external sources and residues left on the plated surfaces from the use of abrasive cleaners or polishes.
- Repair or replacement of parts that are subject to normal wear and tear during the warranty period. These parts include: paint, wood, pellet and coal gaskets, firebricks, grates, flame guides, batteries and the discoloration of glass.
- Expansion, contraction, or movement of certain parts causing noise. These conditions are normal and complaints related to this noise are not covered by this warranty.
- Damages resulting from: (1) failure to install, operate, or maintain the appliance in accordance with the installation instructions, operating instructions, and listing agent identification label furnished with the appliance; (2) failure to install the appliance in accordance with local building codes; (3) shipping or improper handling; (4) improper operation, abuse, misuse, continued operation with damaged, corroded or failed components, accident, or improperly/incorrectly performed repairs; (5) environmental conditions, inadequate ventilation, negative pressure, or drafting caused by tightly sealed constructions, insufficient make-up air supply, or handling devices such as exhaust fans or forced air furnaces or other such causes; (6) use of fuels other than those specified in the operating instructions; (7) installation or use of components not supplied with the appliance or any other components not expressly authorized and approved by HHT; (8) modification of the appliance not expressly authorized and approved by HHT in writing; and/or (9) interruptions or fluctuations of electrical power supply to the appliance.
- Non-HHT venting components, hearth components or other accessories used in conjunction with the appliance.
- Any part of a pre-existing fireplace system in which an insert or a decorative gas appliance is installed.
- HHT's obligation under this warranty does not extend to the appliance's capability to heat the desired space. Information is provided to assist the consumer and the dealer in selecting the proper appliance for the application. Consideration must be given to appliance location and configuration, environmental conditions, insulation and air tightness of the structure.

This warranty is void if:

- The appliance has been over-fired or operated in atmospheres contaminated by chlorine, fluorine, or other damaging chemicals. Over-firing can be identified by, but not limited to, warped plates or tubes, rust colored cast iron, bubbling, cracking and discoloration of steel or enamel finishes.
- The appliance is subjected to prolonged periods of dampness or condensation.
- There is any damage to the appliance or other components due to water or weather damage which is the result of, but not limited to, improper chimney or venting installation.

LIMITATIONS OF LIABILITY:

- The owner's exclusive remedy and HHT's sole obligation under this warranty, under any other warranty, express or implied, or in contract, tort or otherwise, shall be limited to replacement, repair, or refund, as specified above. In no event will HHT be liable for any incidental or consequential damages caused by defects in the appliance. Some states do not allow exclusions or limitation of incidental or consequential damages, so these limitations may not apply to you. This warranty gives you specific rights; you may also have other rights, which vary from state to state. EXCEPT TO THE EXTENT PROVIDED BY LAW, HHT MAKES NO EXPRESS WARRANTIES OTHER THAN THE WARRANTY SPECIFIED HEREIN. THE DURATION OF ANY IMPLIED WARRANTY IS LIMITED TO DURATION OF THE EXPRESSED WARRANTY SPECIFIED ABOVE.

1 Listing and Code Approvals

A. Appliance Certification

MODELS: SOLARIS36-ST, SOLARIS36-MR
LABORATORY: Underwriters Laboratories, Inc. (UL)
TYPE: Direct Vent Heater
STANDARD: ANSI Z21.88-2014/CSA 2.33-2014

This product is listed to ANSI standards for “Vented Gas Appliances” and applicable sections of “Gas Burning Heating Appliances for Manufactured Homes and Recreational Vehicles”, and “Gas Fired Appliances for Use at High Altitudes”.

NOTICE: This installation must conform with local codes. In the absence of local codes you must comply with the National Fuel Gas Code, ANSI Z223.1-latest edition in the U.S.A. and the CAN/CGA B149 Installation Codes in Canada.

NOT INTENDED FOR USE AS A PRIMARY HEAT SOURCE.
 This appliance is tested and approved as either supplemental room heat or as a decorative appliance. It should not be factored as primary heat in residential heating calculations.

B. Glass Specifications

Hearth & Home Technologies appliances manufactured with tempered glass may be installed in hazardous locations such as bathtub enclosures as defined by the Consumer Product Safety Commission (CPSC). The tempered glass has been tested and certified to the requirements of **ANSI Z97.1** and **CPSC 16 CFR 1202** (Safety Glazing Certification Council **SGCC# 1595** and **1597**. Architectural Testing, Inc. Reports **02-31919.01** and **02-31917.01**).

This statement is in compliance with **CPSC 16 CFR Section 1201.5** “Certification and labeling requirements” which refers to **15 U.S. Code (USC) 2063** stating “...Such certificate shall accompany the product or shall otherwise be furnished to any distributor or retailer to whom the product is delivered.”

Some local building codes require the use of tempered glass with permanent marking in such locations. Glass meeting this requirement is available from the factory. Please contact your dealer or distributor to order.

C. BTU Specifications

Models (U.S. or Canada)		Maximum Input BTU/h	Minimum Input BTU/h	Orifice Size (DMS)	
SOLARIS36-ST SOLARIS36-MR	NG	US (0-2000 FT)	29,500	-	38
		CANADA (2000-4500 FT)	27,000	-	39
	LP	US (0-2000 FT)	29,500	-	52
		CANADA (2000-4500 FT)	27,000	-	53

D. High Altitude Installations

NOTICE: If the heating value of the gas has been reduced, these rules do not apply. Check with your local gas utility or authorities having jurisdiction.

When installing above 2000 feet elevation:

- In the USA: Reduce input rate 4% for each 1000 feet above 2000 feet.
- In CANADA: Reduce input rate 10% for elevations between 2000 feet and 4500 feet. Above 4500 feet, consult local gas utility.

Check with your local gas utility to determine proper orifice size.

E. Non-Combustible Materials Specification

Material which will not ignite and burn. Such materials are those consisting entirely of steel, iron, brick, tile, concrete, slate, glass or plasters, or any combination thereof.

Materials that are reported as passing **ASTM E 136, Standard Test Method for Behavior of Materials in a Vertical Tube Furnace at 750 °C** shall be considered non-combustible materials.

F. Combustible Materials Specification

Materials made of or surfaced with wood, compressed paper, plant fibers, plastics, or other material that can ignite and burn, whether flame proofed or not, or plastered or unplastered shall be considered combustible materials.

G. Electrical Codes

NOTICE: This appliance must be electrically wired and grounded in accordance with local codes or, in the absence of local codes, with **National Electric Code ANSI/NFPA 70-latest edition** or the **Canadian Electric Code CSA C22.1**.

- A 110-120 VAC circuit for this product must be protected with ground-fault circuit-interrupter protection, in compliance with the applicable electrical codes, when it is installed in locations such as in bathrooms or near sinks.

Note: The following requirements reference various Massachusetts and national codes not contained in this document.

H. Requirements for the Commonwealth of Massachusetts

For all side wall horizontally vented gas fueled equipment installed in every dwelling, building or structure used in whole or in part for residential purposes, including those owned or operated by the Commonwealth and where the side wall exhaust vent termination is less than seven (7) feet above finished grade in the area of the venting, including but not limited to decks and porches, the following requirements shall be satisfied:

Installation of Carbon Monoxide Detectors

At the time of installation of the side wall horizontal vented gas fueled equipment, the installing plumber or gas fitter shall observe that a hard wired carbon monoxide detector with an alarm and battery back-up is installed on the floor level where the gas equipment is to be installed. In addition, the installing plumber or gas fitter shall observe that a battery operated or hard wired carbon monoxide detector with an alarm is installed on each additional level of the dwelling, building or structure served by the side wall horizontal vented gas fueled equipment. It shall be the responsibility of the property owner to secure the services of qualified licensed professionals for the installation of hard wired carbon monoxide detectors.

In the event that the side wall horizontally vented gas fueled equipment is installed in a crawl space or an attic, the hard wired carbon monoxide detector with alarm and battery back-up may be installed on the next adjacent floor level.

In the event that the requirements of this subdivision can not be met at the time of completion of installation, the owner shall have a period of thirty (30) days to comply with the above requirements; provided, however, that during said thirty (30) day period, a battery operated carbon monoxide detector with an alarm shall be installed.

Approved Carbon Monoxide Detectors

Each carbon monoxide detector as required in accordance with the above provisions shall comply with NFPA 720 and be ANSI/UL 2034 listed and IAS certified.

Signage

A metal or plastic identification plate shall be permanently mounted to the exterior of the building at a minimum height of eight (8) feet above grade directly in line with the exhaust vent terminal for the horizontally vented gas fueled heating appliance or equipment. The sign shall read, in print size no less than one-half (1/2) in. in size, "**GAS VENT DIRECTLY BELOW. KEEP CLEAR OF ALL OBSTRUCTIONS**".

Inspection

The state or local gas inspector of the side wall horizontally vented gas fueled equipment shall not approve the installation unless, upon inspection, the inspector observes carbon monoxide detectors and signage installed in accordance with the provisions of 248 CMR 5.08(2)(a)1 through 4.

Exemptions

The following equipment is exempt from 248 CMR 5.08(2)(a)1 through 4:

- The equipment listed in Chapter 10 entitled "Equipment Not Required To Be Vented" in the most current edition of NFPA 54 as adopted by the Board; and
- Product Approved side wall horizontally vented gas fueled equipment installed in a room or structure separate from the dwelling, building or structure used in whole or in part for residential purposes.

MANUFACTURER REQUIREMENTS

Gas Equipment Venting System Provided

When the manufacturer of Product Approved side wall horizontally vented gas equipment provides a venting system design or venting system components with the equipment, the instructions provided by the manufacturer for installation of the equipment and the venting system shall include:

- Detailed instructions for the installation of the venting system design or the venting system components; and
- A complete parts list for the venting system design or venting system.

Gas Equipment Venting System NOT Provided

When the manufacturer of a Product Approved side wall horizontally vented gas fueled equipment does not provide the parts for venting the flue gases, but identifies "special venting systems", the following requirements shall be satisfied by the manufacturer:

- The referenced "special venting system" instructions shall be included with the appliance or equipment installation instructions; and
- The "special venting systems" shall be Product Approved by the Board, and the instructions for that system shall include a parts list and detailed installation instructions.

A copy of all installation instructions for all Product Approved side wall horizontally vented gas fueled equipment, all venting instructions, all parts lists for venting instructions, and/or all venting design instructions shall remain with the appliance or equipment at the completion of the installation.

See Gas Connection section for additional Commonwealth of Massachusetts requirements.

A. Gas Fireplace Safety

WARNING! DO NOT operate fireplace before reading and understanding operating instructions. Failure to operate fireplace according to operating instructions could cause fire or injury.



HOT GLASS WILL CAUSE BURNS.

DO NOT TOUCH GLASS UNTIL COOLED.

NEVER ALLOW CHILDREN TO TOUCH GLASS.

- Keep children away.
- CAREFULLY SUPERVISE children in same room as fireplace.
- Alert children and adults to hazards of high temperatures.

High temperatures may ignite clothing or other flammable materials.

- Clothing, furniture, draperies, and other flammable materials must not be placed on or near the appliance.

A barrier designed to reduce the risk of burns from the hot viewing glass is provided with this appliance and shall be installed for the protection of children and other at-risk individuals. DO NOT operate the appliance with the barrier removed. If the barrier becomes damaged, the barrier shall be replaced with the manufacturer's barrier for this appliance.

Contact your dealer or Hearth & Home Technologies if the barrier is not present or help is needed to properly install one.

Young children should be carefully supervised when they are in the same room as the appliance. Toddlers, young children and others may be susceptible to accidental contact burns.

- A physical barrier is recommended if there are at risk individuals in the house.
- To restrict access to a fireplace or stove, install an adjustable safety gate to keep toddlers, young children and other at risk individuals out of the room and away from hot surfaces.
- Install a switch lock or a wall/remote control with child protection lockout feature.
- Keep remote controls out of reach of children.
- Never leave children alone near a hot fireplace, whether operating or cooling down.

- Teach children to NEVER touch the fireplace.
- Consider not using the fireplace when children will be present.

Contact your dealer for more information, or visit: www.hpba.org/safety-information.

To prevent unintended operation when not using your fireplace for an extended period of time (summer months, vacations, trips, etc):

- Remove batteries from remote controls.
- Unplug 6 volt adapter plug.

B. Your Fireplace

WARNING! DO NOT operate fireplace before reading and understanding operating instructions. Failure to operate fireplace according to operating instructions could cause fire or injury.

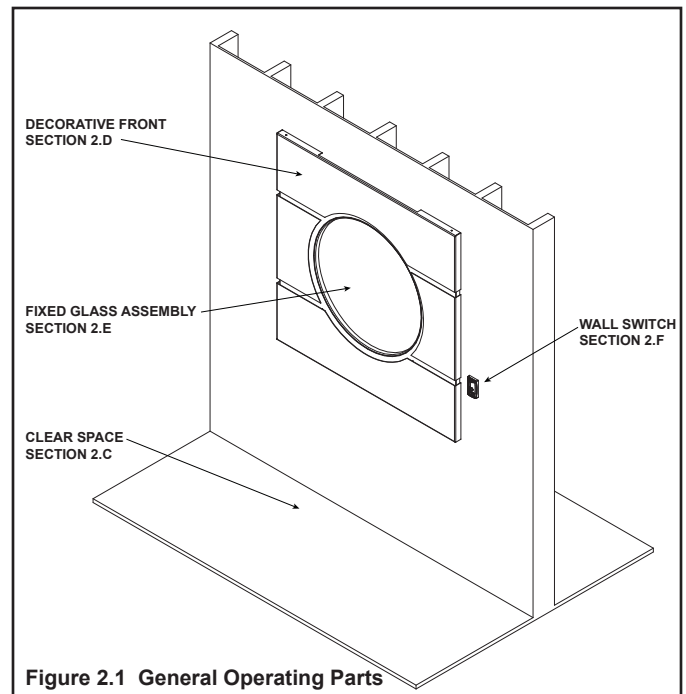

Figure 2.1 General Operating Parts

C. Clear Space

WARNING! DO NOT place combustible objects in front of the fireplace or block openings. High temperatures may start a fire. See Figure 2.2.

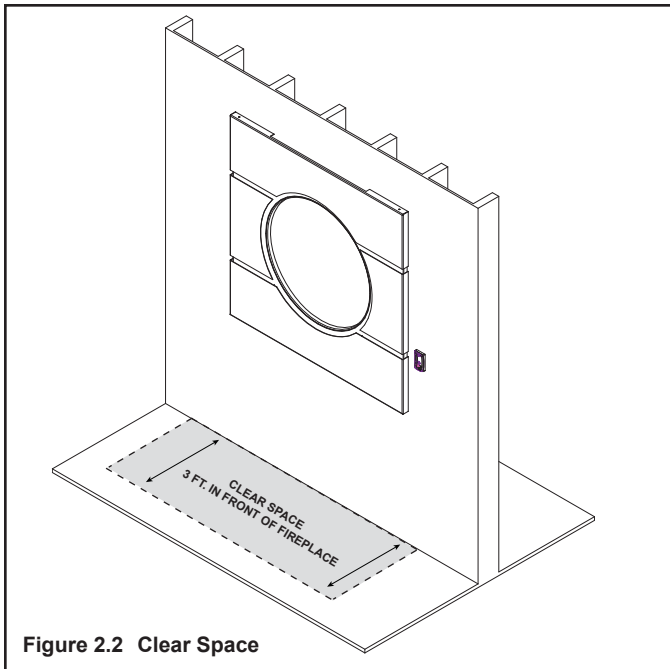

Figure 2.2 Clear Space

D. Decorative Fronts

WARNING! Risk of Fire! Install *ONLY* doors or fronts approved by Hearth & Home Technologies. Unapproved doors or fronts may cause fireplace to overheat.

This fireplace has been supplied with an integral barrier to prevent direct contact with the fixed glass panel. DO NOT operate the fireplace with the barrier removed.

Contact your dealer or Hearth & Home Technologies if the barrier is not present or help is needed to properly install one.

For more information refer to the instructions supplied with your decorative front.

E. Fixed Glass Assembly

See Section 14.A.

F. Remote Control, Wall Controls and Wall Switches

Follow the instructions supplied with the optional control to operate your fireplace:

For safety:

- Install a switch lock or a wall/remote control with child protection lockout feature.
- Keep remote controls out of reach of children.

See your dealer if you have questions.

G. Before Lighting Fireplace

Before operating this fireplace for the first time, **have a qualified service technician:**

- Verify all shipping materials have been removed from inside and/or underneath the firebox.
- Check the wiring.
- Check the air shutter adjustment.
- Ensure that there are no gas leaks.
- Ensure that the glass is sealed and in the proper position and that the integral barrier is in place.

WARNING! Risk of Fire or Asphyxiation! DO NOT operate fireplace with fixed glass assembly removed.

H. Lighting Instructions (PVI-SLP-B)

Note: There is a 30 SECOND DELAY before your Solaris fireplace lights. This allows the fan to reach operating speed and remove residual gas from the combustion chamber.

Note: For your remote or wall control to work properly, the OFF/ON/REMOTE switch must be in the ON position as described in Section 12. See your dealer if you have any questions.

H. Lighting Instructions (IPI) (continued)

FOR YOUR SAFETY READ BEFORE LIGHTING



WARNING: If you do not follow these instructions exactly, a fire or explosion may result causing property damage, personal injury or loss of life.

- A. This appliance is equipped with an intermittent pilot ignition (IPI) device which automatically lights the burner. **DO NOT** try to light the burner by hand.
- B. **BEFORE LIGHTING**, smell all around the appliance area for gas. Be sure to smell next to the floor because some gas is heavier than air and will settle on the floor.
- WHAT TO DO IF YOU SMELL GAS**
- **DO NOT** try to light any appliance.
 - **DO NOT** touch any electric switch; do not use any phone in your building.
 - Immediately call your gas supplier from a neighbor's phone. Follow the gas supplier's instructions.
 - If you cannot reach your gas supplier, call the fire department.
- C. Use only your hand to push in or turn the gas control knob. Never use tools. If the knob will not push in or turn by hand, **DO NOT** try to repair it, call a qualified service technician. Force or attempted repair may result in a fire or explosion.
- D. **DO NOT** use this appliance if any part has been under water. Immediately call a qualified service technician to inspect the appliance and to replace any part of the control system and any gas control which has been under water.

LIGHTING INSTRUCTIONS (IPI)

1. This appliance is equipped with an ignition device which automatically lights the burner. **DO NOT** try to light the burner by hand.
2. Wait five (5) minutes to clear out any gas. Then smell for gas, including near the floor. If you smell gas, **STOP!** Follow "B" in the Safety Information located on the top of this label. If you do not smell gas, go to next step.
3. To light the burner:
Equipped with wall switch: Turn ON/OFF switch to ON.
Equipped with remote or wall control: Press ON or FLAME button.
Equipped with thermostat: Set temperature to desired setting.
4. If the appliance does not light after three tries, call your service technician or gas supplier.

**GAS
VALVE**

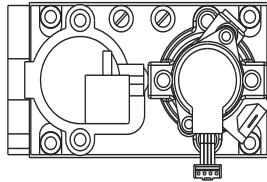

TO TURN OFF GAS TO APPLIANCE

1. Equipped with wall switch: Turn ON/OFF switch to OFF.
Equipped with remote or wall control: Press OFF button.
Equipped with thermostat: Set temperature to lowest setting.
2. Service technician should turn off electric power to the control when performing service.



DANGER



**HOT GLASS WILL CAUSE BURNS.
DO NOT TOUCH GLASS UNTIL COOLED.
NEVER ALLOW CHILDREN TO TOUCH GLASS.**

A barrier designed to reduce the risk of burns from the hot viewing glass is provided with this appliance and shall be installed for the protection of children and other at-risk individuals.

WARNING:

DO NOT CONNECT LINE VOLTAGE (110/120 VAC OR 220/240 VAC) TO THE CONTROL VALVE.

Improper installation, adjustment, alteration, service or maintenance can cause injury or property damage. Refer to the owner's information manual provided with this appliance. For assistance or additional information, consult a qualified installer, service agency or the gas supplier.

This appliance needs fresh air for safe operation and must be installed so there are provisions for adequate combustion and ventilation air.

If not installed, operated, and maintained in accordance with the manufacturer's instructions, this product could expose you to substances in fuel or fuel combustion which are known to the State of California to cause cancer, birth defects, or other reproductive harm.

Keep burner and control compartment clean. See installation and operating instructions accompanying appliance.

CAUTION:

Hot while in operation. **DO NOT** touch. Keep children, clothing, furniture, gasoline and other liquids having flammable vapors away.

DO NOT operate the appliance with fixed glass assembly removed, cracked or broken. Replacement of the fixed glass assembly should be done by a licensed or qualified service person.

NOT FOR USE WITH SOLID FUEL

For use with natural gas and propane. A conversion kit, as supplied by the manufacturer, shall be used to convert this appliance to the alternate fuel.

Also Certified for Installation in a Bedroom or a Bed sitting Room.

This appliance must be installed in accordance with local codes, if any; if none, follow the *National Fuel Gas Code, ANSI Z223.1/ NFPA 54, or the National Gas and Propane Installation code, CSA B149.1.*

For additional information on operating your
Hearth & Home Technologies fireplace, please refer to www.fireplaces.com.

593-913i

I. After Fireplace is Lit

Initial Break-in Procedure

- The fireplace should be run three to four hours continuously on high.
- Turn the fireplace off and allow it to completely cool.
- Remove one fixed glass assembly. See Section 14.A.
- Clean fixed glass assemblies. See Section 3.B.
- Replace the fixed glass assembly and run continuously on high an additional 12 hours.

This cures the materials used to manufacture the fireplace.

NOTICE! Open windows for air circulation during fireplace break-in.

- *Some people may be sensitive to smoke and odors.*
- *Smoke detectors may activate.*

J. Frequently Asked Questions

ISSUE	SOLUTIONS
Condensation on the glass	This is a result of gas combustion and temperature variations. As the fireplace warms, this condensation will disappear.
Blue flames	This is a result of normal operation and the flames will begin to yellow as the fireplace is allowed to burn for 20 to 40 minutes.
Odor from fireplace	When first operated, this fireplace may release an odor for the first several hours. This is caused by the curing of the paint and the burning off of any oils remaining from manufacturing. Odor may also be released from finishing materials and adhesives used around the fireplace.
Film on the glass	This is a normal result of the curing process of the paint and logs. Glass should be cleaned within 3 to 4 hours of initial burning to remove deposits left by oils from the manufacturing process. A non-abrasive cleaner such as gas fireplace glass cleaner may be necessary. See your dealer.
Metallic noise	Noise is caused by metal expanding and contracting as it heats up and cools down, similar to the sound produced by a furnace or heating duct. This noise does not affect the operation or longevity of the fireplace.
Is it normal to see the pilot flame burn continually?	In an intermittent pilot ignition system (IPI), the pilot flame should turn off when appliance is turned off. Some optional control systems available with IPI models may allow pilot flame to remain lit.

3 Maintenance and Service

Any safety screen or guard removed for servicing must be replaced prior to operating the fireplace.

When properly maintained, your fireplace will give you many years of trouble-free service. We recommend annual service by a qualified service technician.

A. Maintenance Tasks-Homeowner

Installation and repair should be done by a qualified service technician only. The fireplace should be inspected before use and at least annually by a professional service person.

The following tasks may be performed annually by the homeowner. If you are uncomfortable performing any of the listed tasks, please call your dealer for a service appointment.

More frequent cleaning may be required due to lint from carpeting or other factors. Control compartment, burner and circulating air passageway of the fireplace must be kept clean.

CAUTION! Risk of Burns! *The fireplace should be turned off and cooled before servicing.*

Decorative Fronts

Frequency: Annually

By: Homeowner

Tools needed: Protective gloves, stable work surface

- Assess condition of screen and replace as necessary.
- Inspect for scratches, dents or other damage and repair as necessary.
- Check that openings are not blocked.
- Vacuum and dust surfaces.

Remote Control

Frequency: Seasonally

By: Homeowner

Tools needed: Replacement batteries and remote control instructions.

- Locate remote control transmitter and receiver.
- Verify operation of remote. Refer to remote control operation instructions for proper calibration and setup procedure.
- Replace batteries as needed in remote transmitters and battery-powered receivers.
- Place remote control out of reach of children.

If not using your fireplace for an extended period of time (summer months, vacations/trips, etc), to prevent unintended operation:

- Remove batteries from remote controls.
- Unplug 6 volt transformer plug.

Venting

Frequency: Seasonally

By: Homeowner

Tools needed: Protective gloves and safety glasses.

- Inspect venting and termination cap for blockage or obstruction such plants, bird nests, leaves, snow, debris, etc.
- Verify termination cap clearance to subsequent construction (building additions, decks, fences, or sheds). See Section 6.
- Inspect for corrosion or separation.
- Verify weather stripping, sealing and flashing remains intact.
- Inspect draft shield to verify it is not damaged or missing.

B. Maintenance Tasks-Qualified Service Technician

The following tasks must be performed by a qualified service technician.

Glass Cleaning

Frequency: Seasonally

By: Qualified Service Technician

Tools Needed: Protective gloves, glass cleaner, drop cloth, 3/8 in. nut driver and a stable work surface.

CAUTION! Handle fixed glass assembly with care. *Glass is breakable.*

- *Avoid striking, scratching or slamming glass*
- *Avoid abrasive cleaners*
- **DO NOT** clean glass while it is hot
- Prepare a work area large enough to accommodate fixed glass assembly and door frame by placing a drop cloth on a flat, stable surface.

Note: Fixed glass assembly and gasketing may have residue that can stain carpeting or floor surfaces.

- Remove decorative front from fireplace and set aside on work surface.
- See Section 14.A for instructions to remove fixed glass assembly.
- Clean glass with a non-abrasive commercially available cleaner.
 - Light deposits: Use a soft cloth with soap and water
 - Heavy deposits: Use commercial fireplace glass cleaner (consult with your dealer)
- Carefully set fixed glass assembly in place on fireplace. Hold glass in place with one hand and secure nuts on to threaded studs with the other hand
- Reinstall decorative front.

L.E.D Replacement

Frequency: As needed

By: Qualified Service Technician

Tools needed: Protective gloves, replacement LED Strips, 3/8 in nut driver.

- Remove four panels from decorative front.
- Unplug LED wire assembly from control box.
- Remove large decorative front panel from fireplace.
- Loosen three 3/8 in. nuts that attach the LED strip to the decorative panel.
- Unplug wire from LED strip.
- Plug the wire into the new LED strip.
- Place LED strip onto the three threaded studs on the decorative panel.
- Tighten the three 3/8 in. nuts to secure the LED strips in place.
- Replace the large decorative panel on the fireplace.
- Replace the four panels on the decorative front.

Gasket Seal and Glass Assembly Inspection

Frequency: Annually

By: Qualified Service Technician

Tools needed: Protective gloves, drop cloth and a stable work surface.

- Inspect gasket seal and its condition.
- Inspect fixed glass assembly for scratches and nicks that can lead to breakage when exposed to heat.
- Confirm there is no damage to glass or glass frame. Replace as necessary.
- Verify that fixed glass assembly is properly retained and attachment components are intact and not damaged. Replace as necessary.

Firebox

Frequency: Annually

By: Qualified Service Technician

Tools needed: Protective gloves, sandpaper, steel wool, cloths, mineral spirits, primer and touch-up paint.

- Inspect for paint condition, warped surfaces, corrosion or perforation. Sand and repaint as necessary.
- Replace fireplace if firebox has been perforated.

Control Compartment and Firebox Top

Frequency: Annually

By: Qualified Service Technician

Tools needed: Protective gloves, vacuum cleaner, dust cloths

- Vacuum and wipe out dust, cobwebs, debris or pet hair. Use caution when cleaning these areas. Screw tips that

have penetrated the sheet metal are sharp and should be avoided.

- Remove all foreign objects.

Burner Ignition and Operation

Frequency: Annually

By: Qualified Service Technician

Tools needed: Protective gloves, vacuum cleaner, whisk broom, flashlight, voltmeter, indexed drill bit set, and a manometer.

- Verify burner is properly secured and aligned with pilot or igniter.
- Check for smooth lighting. Verify that there is no ignition delay.
- Inspect for lifting or other flame problems.
- Verify air shutter setting is correct. See Section 14 for required air shutter setting. Verify air shutter is clear of dust and debris.
- Inspect orifice for soot, dirt and corrosion. Verify orifice size is correct. See Service Parts List for proper orifice sizing.
- Verify manifold and inlet pressures. Adjust regulator as required.
- Inspect pilot flame pattern and strength. See Figure 3.1 for proper pilot flame pattern. Clean or replace orifice spud as necessary.
- Inspect IPI flame sensing rod for soot, corrosion and deterioration. Polish with fine steel wool or replace as required.
- Verify that there is not a short in flame sense circuit by checking continuity between pilot hood and flame sensing rod. Replace pilot as necessary.



Figure 3.1 IPI Pilot Flame Patterns

PVI-SLP-B Maintenance

CAUTION: Before performing any maintenance or repair to the power vent assembly, make sure electrical power is disconnected to the fireplace.

Frequency: Annually

By: Qualified Service Technician

Tools needed: Protective gloves, Phillips screwdriver, 3/8 in. Nut Driver, 1/4 Nut Driver

- Vent System: Inspect all components and connections annually. Replace, seal, or tighten pipe connections if necessary.
- PVI-SLP-B Cover: Inspect at least annually. Ensure mesh is free of dust and debris.
- Motor: The fan motor bearings are sealed and no further lubrication is necessary.

To access the motor, vacuum switch or pressure sense tube. Refer to Figure 3.2.

If the motor needs to be removed, take out the four screws that attach the collar to the wall and the five nuts holding the motor down as shown in Figure 3.3.

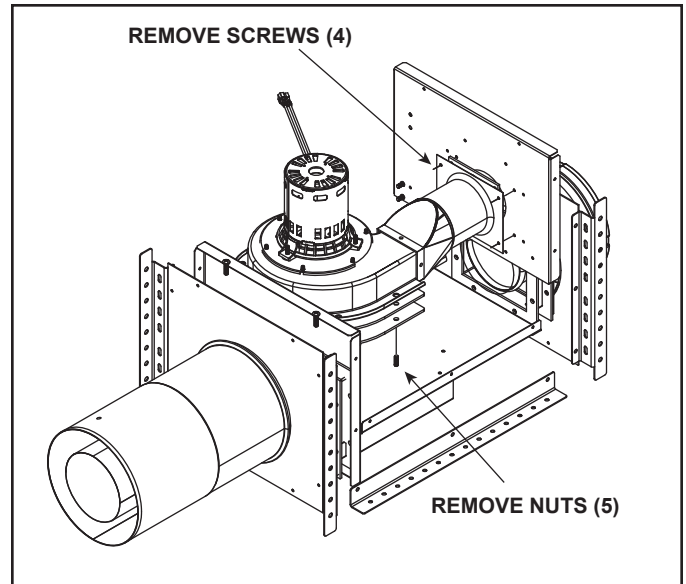

Figure 3.3 Motor/Blower Service

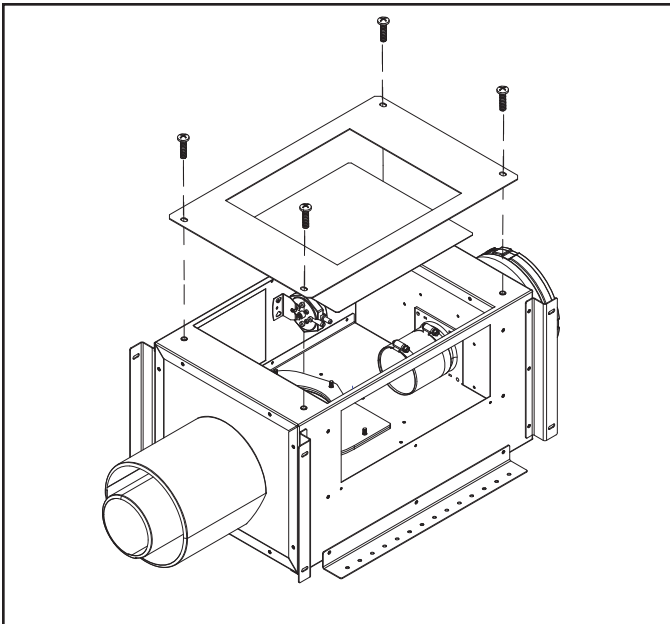

Figure 3.2 Maintenance Access

4 Getting Started

Installer Guide

A. Typical Appliance System

NOTICE: Illustrations and photos reflect typical installations and are for design purposes only. Illustrations/diagrams are not drawn to scale. Actual product may vary from pictures in manual.

Note: Dual venting configurations **ARE NOT** allowed. Appliance **MUST** be vented **EITHER** vertically **OR** horizontally.

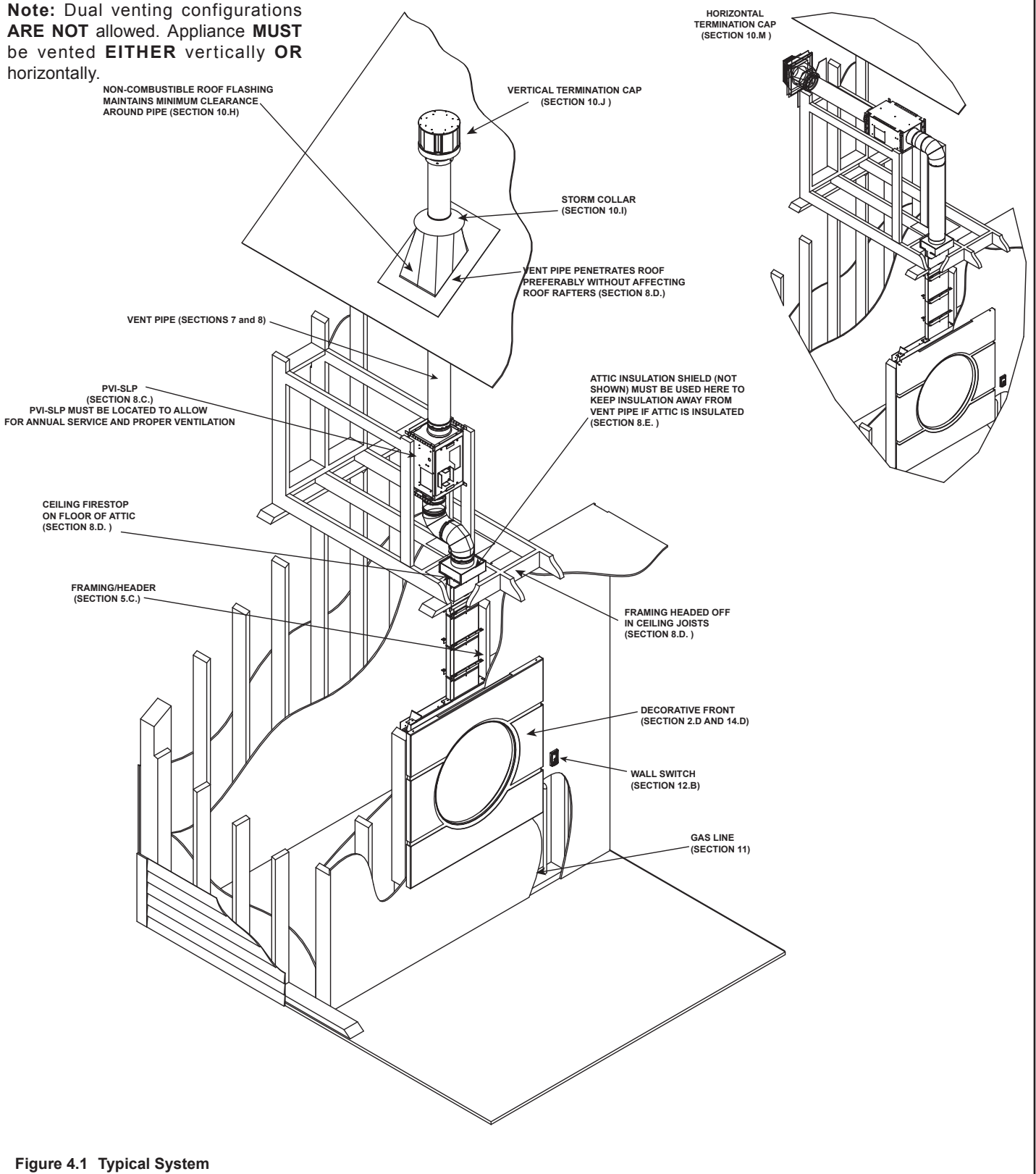

Figure 4.1 Typical System

B. Design and Installation Considerations

Heat & Glo direct vent gas appliances are designed to operate with all combustion air siphoned from outside of the building and all exhaust gases expelled to the outside. No additional outside air source is required.

Installation **MUST** comply with local, regional, state and national codes and regulations. Consult insurance carrier, local building inspector, fire officials or authorities having jurisdiction over restrictions, installation inspection and permits.

Before installing, determine the following:

- Where the appliance is to be installed.
- Where the PVI-SLP-B is to be installed. The PVI-SLP-B must be located to allow for annual service and proper ventilation.
- The vent system configuration to be used.
- Gas supply piping requirements.
- Electrical wiring requirements.
- Framing and finishing details.
- Whether optional accessories are desired.



Installation and service of this appliance should be performed by qualified personnel. Hearth & Home Technologies suggests NFI certified or factory trained professionals, or technicians supervised by an NFI certified professional.

Improper installation, adjustment, alteration, service or maintenance can cause injury or property damage. For assistance or additional information, consult a qualified service technician, service agency or your dealer.

C. Tools and Supplies Needed

Before beginning the installation be sure that the following tools and building supplies are available.

Tape measure	Framing material
Pliers	Flat blade screwdriver
Hammer	Phillips screwdriver
Gloves	Framing square
Voltmeter	Electric drill and bits (1/4 in.)
Plumb line	Safety glasses
Level	Reciprocating saw
Manometer	Non-corrosive leak check solution
1/2 - 3/4 in. length, #6 or #8 Self-drilling screws	
Caulking material (300°F minimum continuous exposure rating)	

D. Inspect Appliance and Components

- Carefully remove the appliance and components from the packaging.
- The vent system components and decorative doors and fronts may be shipped in separate packages.
- Report to your dealer any parts damaged in shipment, particularly the condition of the glass.
- **Read all of the instructions before starting the installation. Follow these instructions carefully during the installation to ensure maximum safety and benefit.**

WARNING! Risk of Fire or Explosion! Damaged parts could impair safe operation. DO NOT install damaged, incomplete or substitute components. Keep appliance dry.

Hearth & Home Technologies disclaims any responsibility for, and the warranty will be voided by, the following actions:

- Installation and use of any damaged appliance or vent system component.
- Modification of the appliance or vent system.
- Installation other than as instructed by Hearth & Home Technologies.
- Improper positioning of the glass door.
- Installation and/or use of any component part not approved by Hearth & Home Technologies.

Any such action may cause a fire hazard.

WARNING! Risk of Fire, Explosion or Electric Shock! DO NOT use this appliance if any part has been under water. Call a qualified service technician to inspect the appliance and to replace any part of the control system and/or gas control which has been under water.

5 Framing and Clearances

A. Selecting Appliance Location

When selecting a location for the appliance it is important to consider the required minimum clearances to walls (see Figure 5.1).

WARNING! Risk of Fire or Burns! Provide adequate clearance around air openings and for service access. **Due to high temperatures, the appliance should be located out of traffic and away from furniture and draperies.**

NOTICE: Illustrations reflect typical installations and are **FOR DESIGN PURPOSES ONLY**. Illustrations/diagrams are not drawn to scale. Actual installation may vary due to individual design preference.

NOTICE: This See-Through appliance is **NOT** designed or approved for an indoor/outdoor application.

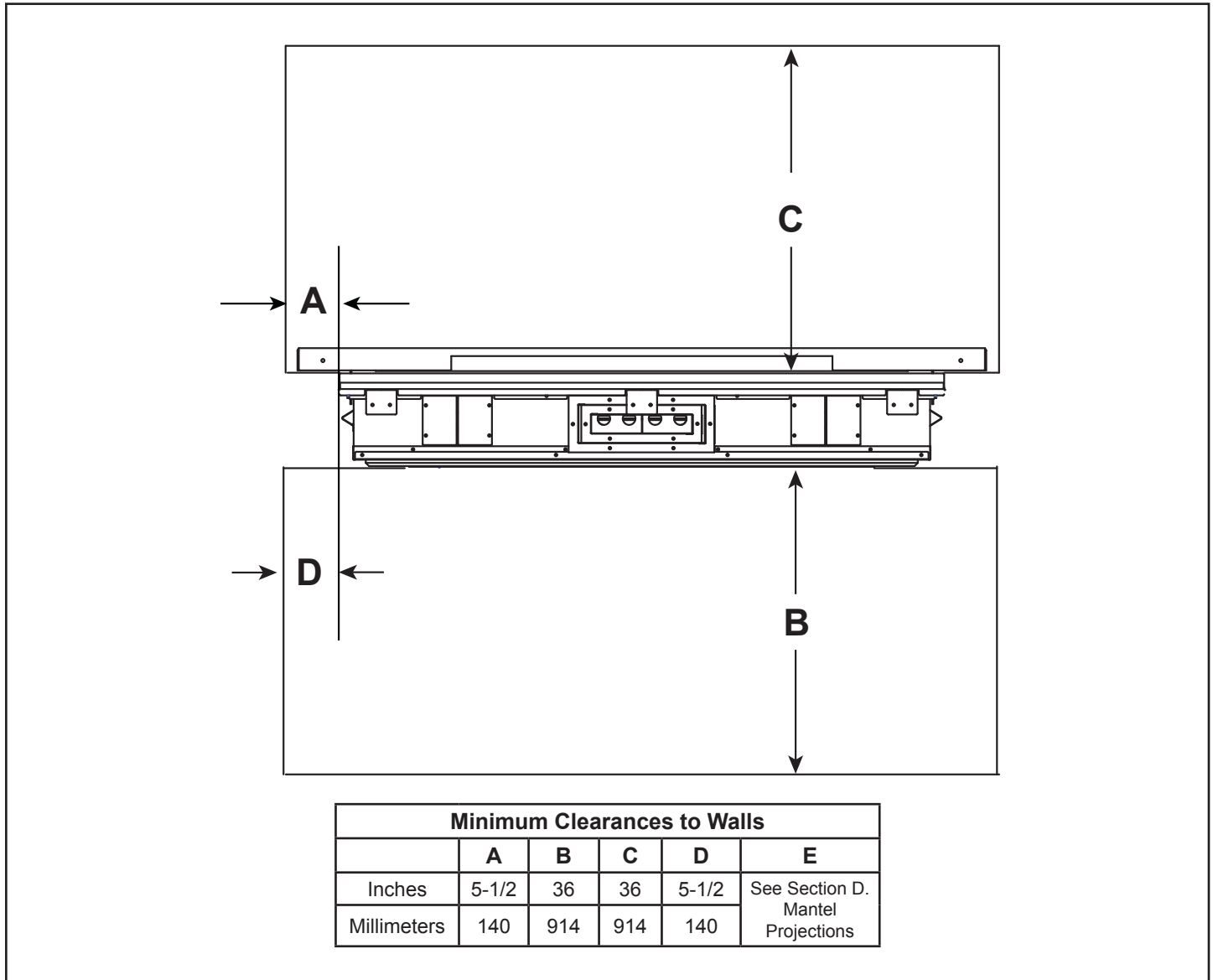

Figure 5.1 Appliance Locations

B. Constructing the Appliance Chase

A chase is a vertical box-like structure built to enclose the gas appliance and/or its vent system. In cooler climates the vent should be enclosed inside the chase.

NOTICE: Treatment of ceiling firestops and wall shield firestops and construction of the chase may vary with the type of building. These instructions are not substitutes for the requirements of local building codes. Therefore, you **MUST** check local building codes to determine the requirements to these steps.

Chases should be constructed per regional codes. The chase should not break the outside building envelope in any manner.

Walls, ceiling, base plate and cantilever floor of the chase should be insulated. Vapor and air infiltration barriers should be installed in the chase as per regional codes for the rest of the home.

To further prevent drafts, the wall shield and ceiling firestops should be caulked with caulk with a minimum of 300°F continuous exposure rating to seal gaps. Gas line holes and other openings should be caulked with caulk with a minimum of 300°F continuous exposure rating or stuffed with unfaced insulation.

C. Clearances

NOTICE: Install appliance on hard metal or wood surfaces extending full width and depth. **DO NOT** install directly on carpeting, vinyl, tile or any combustible material other than wood.

WARNING! Risk of Fire! Maintain specified air space clearances to appliance and vent pipe:

- Insulation and other materials must be secured to prevent accidental contact.
- The chase must be properly blocked to prevent blown insulation or other combustibles from entering and making contact with fireplace or chimney.
- Failure to maintain airspace may cause overheating and a fire.

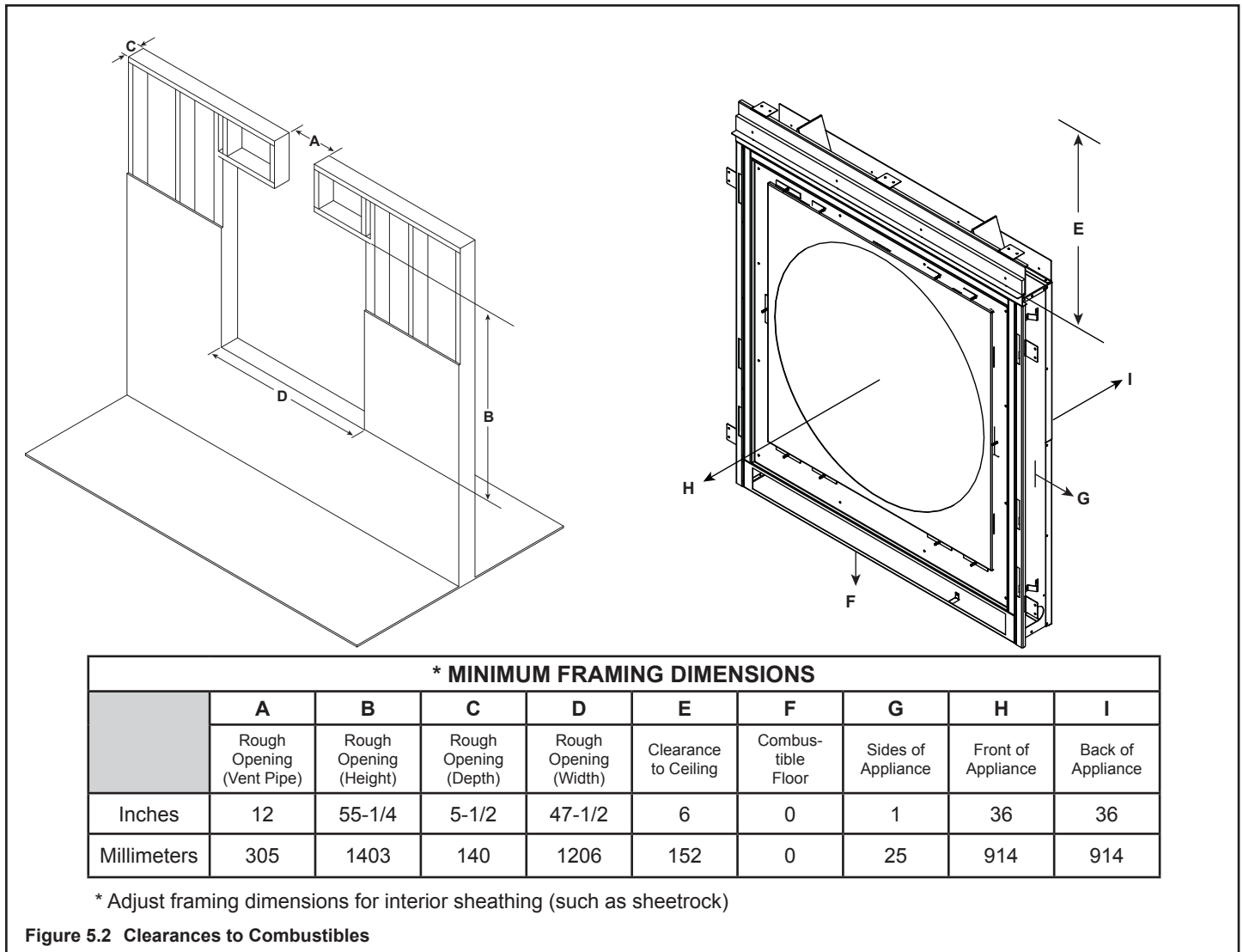
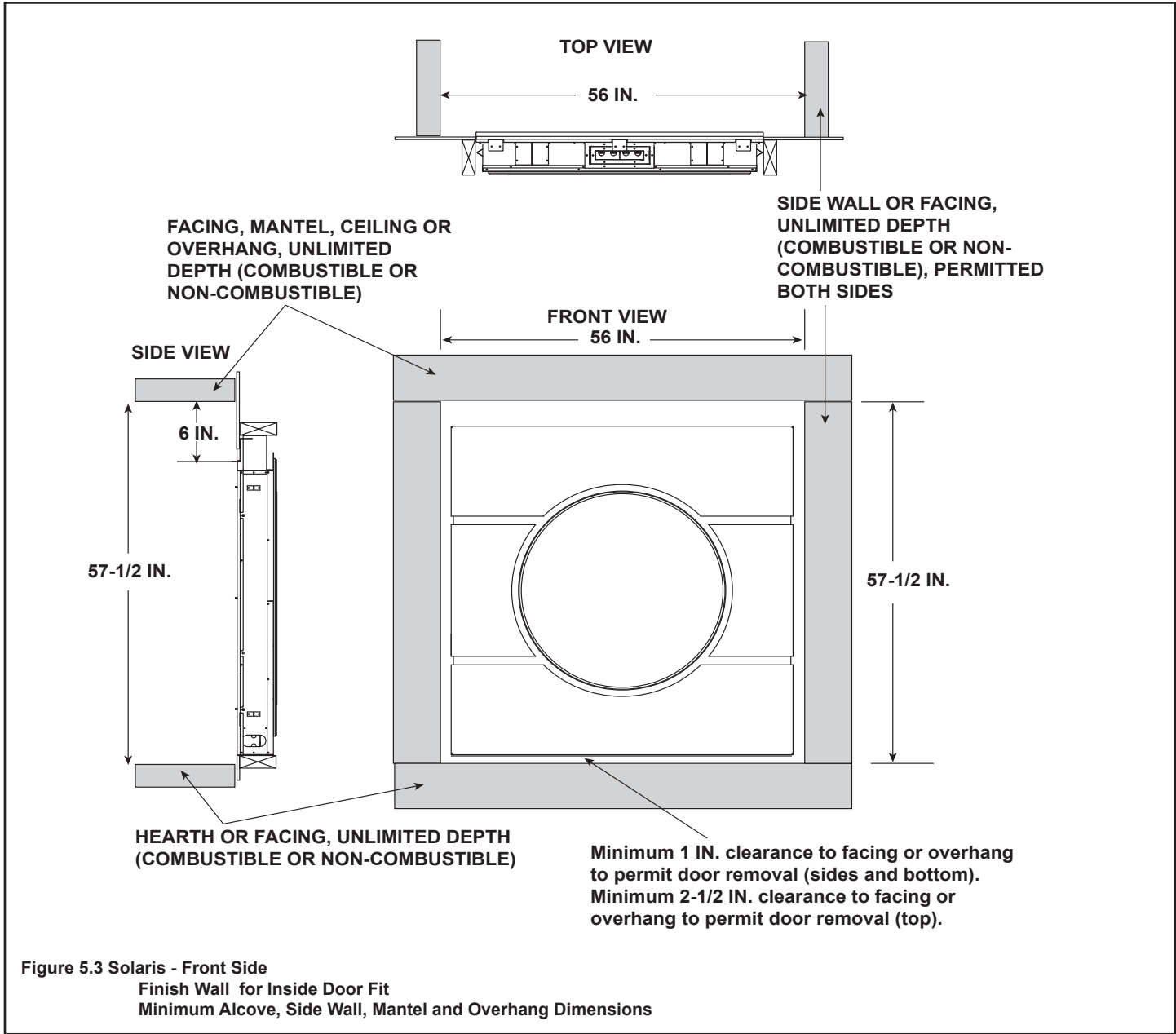

Figure 5.2 Clearances to Combustibles

D. Mantel and Wall Projections

WARNING! Risk of Fire! Comply with all minimum clearances as specified. Framing or finishing material closer than the minimums listed must be constructed entirely of noncombustible materials (i.e., steel studs, concrete board, etc).

Note: The front of the Solaris is the side with access to the controls.



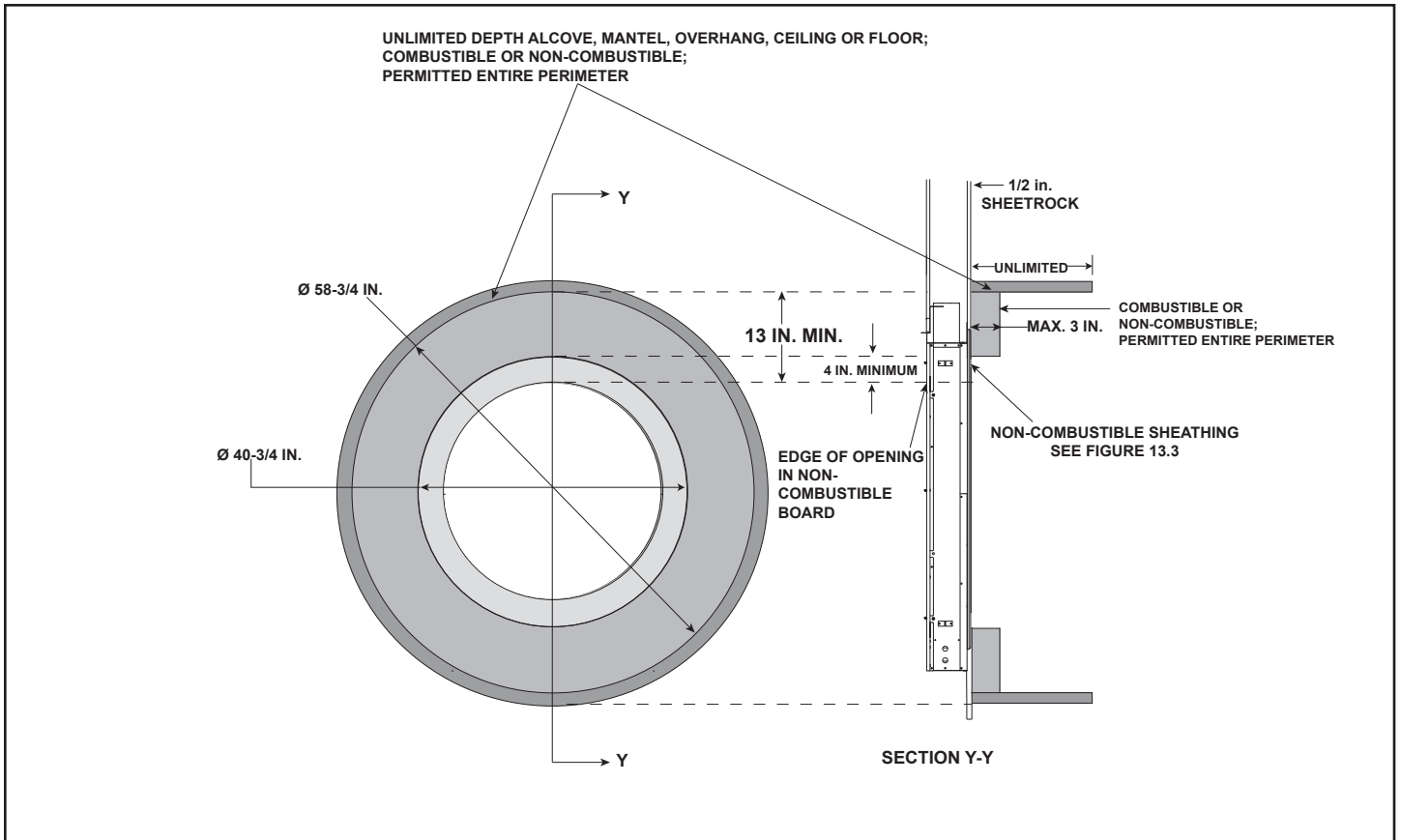

Figure 5.4 Solaris - Back Side
Finish Wall for Overlap Door Fit
Minimum Alcove, Side Wall, Mantel and Overhang Dimensions

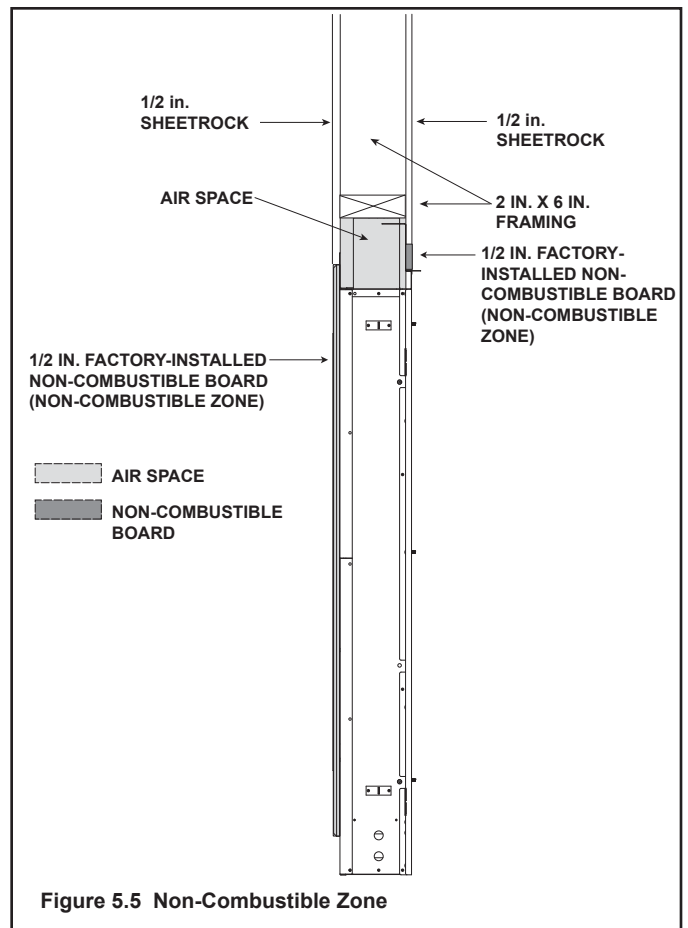

Figure 5.5 Non-Combustible Zone

6 Termination Locations

A. Vent Termination Minimum Clearances

⚠ WARNING

Fire Risk.
Maintain vent clearance to combustibles as specified.

- **DO NOT** pack air space with insulation or other materials.

Failure to keep insulation or other materials away from vent pipe may cause overheating and fire.

Roof Pitch	H (Min.) Ft.
Flat to 6/12.....	1.0*
Over 6/12 to 7/12.....	1.25*
Over 7/12 to 8/12.....	1.5*
Over 8/12 to 9/12.....	2.0*
Over 9/12 to 10/12.....	2.5*
Over 10/12 to 11/12.....	3.25
Over 11/12 to 12/12.....	4.0
Over 12/12 to 14/12.....	5.0
Over 14/12 to 16/12.....	6.0
Over 16/12 to 18/12.....	7.0
Over 18/12 to 20/12.....	7.5
Over 20/12 to 21/12.....	8.0

* 3 foot minimum in snow regions

Figure 6.1 Minimum Height From Roof To Lowest Discharge Opening

A	B
6 in. (minimum) up to 20 in. <i>152 mm/508 mm</i>	18 in. minimum <i>457 mm</i>
20 in. and over	0 in. minimum

* If using decorative cap cover(s), this distance may need to be increased. Refer to the installation instructions supplied with the decorative cap cover.

** In a staggered installation with both gas and wood or fuel oil terminations, the wood or fuel oil termination cap must be higher than the gas termination cap.

Figure 6.2 Staggered Termination Caps

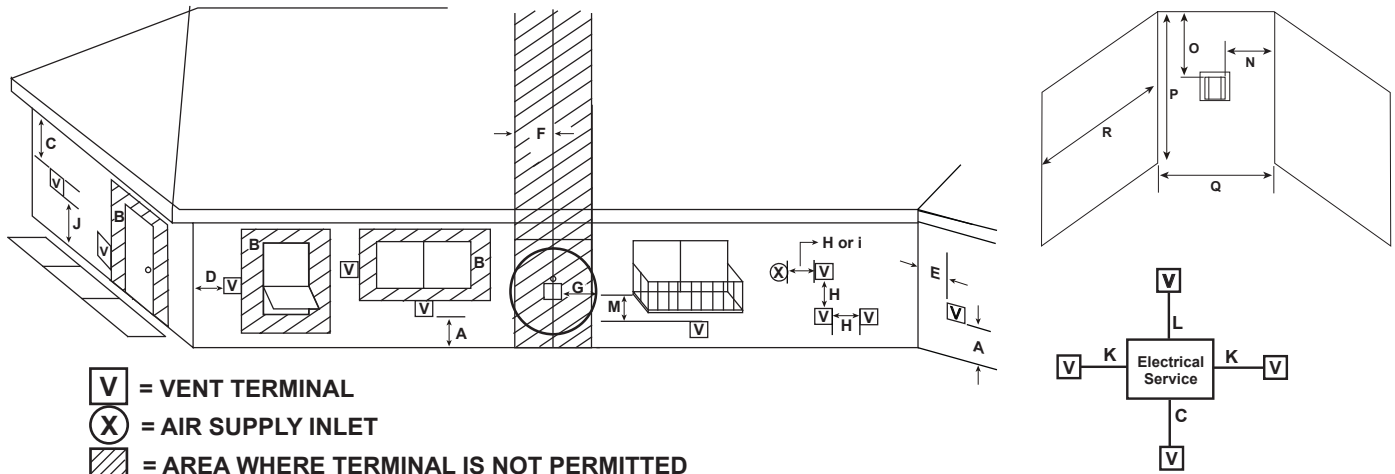

- V** = VENT TERMINAL
- X** = AIR SUPPLY INLET
- Diagonal hatching** = AREA WHERE TERMINAL IS NOT PERMITTED

- A** = 12 inches.....clearances above grade, veranda, porch, deck or balcony
- B** = 12 inches.....clearance to window or door that may be opened, or to permanently closed window
- C** = 18 inches.....clearance below unventilated soffit
18 inches.....clearance below ventilated soffit
30 inches.....clearance below vinyl soffits and electrical service
- D** = 6 inches.....clearance to outside corner
- E** = 6 inches.....clearance to inside corner
- F** = 3 ft. (Canada).....not to be installed above a gas meter/regulator assembly within 3 feet horizontally from the center-line of the regulator
- G** = 3 ft.....clearance to gas service regulator vent outlet
- H** = 12 inches.....clearance to non-mechanical (unpowered) air supply inlet, combustion air inlet or direct-vent termination
- i** = 3 ft. (U.S.A.)
6 ft. (Canada).....clearance to a mechanical (powered) air supply inlet

All mechanical air intakes within 10 feet of a termination cap must be a minimum of 3 feet below termination.

J = 7 ft..... On **public** property: clearance above paved sidewalk or a paved driveway.

A vent shall not terminate directly above a sidewalk or paved driveway which is located between two single family dwellings and serves both dwellings.

- K** = 6 inches.....clearance from sides of electrical service
- L** = 12 inches.....clearance above electrical service
Location of the vent termination must not interfere with access to the electrical service.

M = 18 inches clearance under veranda, porch, deck, balcony or overhang
42 inchesvinyl or composite overhang
Permitted when veranda, porch, deck or balcony is fully open on a minimum of 2 sides beneath the floor.

Covered Alcove Applications

(Spaces open only on one side and with an overhang)

- N** = 6 inches non-vinyl sidewalls
12 inches vinyl sidewalls
- O** = 18 inches non-vinyl soffit and overhang
42 inches vinyl soffit and overhang
- P** = 8 ft.

	Q_{MIN}	R_{MAX}
1 cap	3 feet	2 x Q _{ACTUAL}
2 caps	6 feet	1 x Q _{ACTUAL}
3 caps	9 feet	2/3 x Q _{ACTUAL}
4 caps	12 feet	1/2 x Q _{ACTUAL}
Q_{MIN} = # termination caps x 3 R_{MAX} = (2 / # termination caps) x Q _{ACTUAL}		

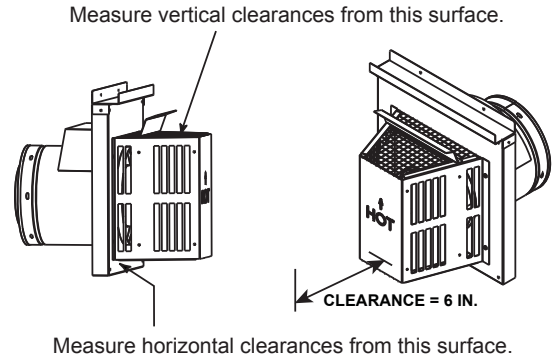

CAUTION! Risk of Burns! Termination caps are **HOT**, consider proximity to doors, traffic areas or where people may pass or gather (sidewalk, deck, patio, etc.). Listed cap shields available. Contact your dealer.

- Local codes or regulations may require different clearances.
- Vent system termination is **NOT** permitted in screened porches.
- Vent system termination is permitted in porch areas with two or more sides open.
- Hearth & Home Technologies assumes no responsibility for the improper performance of the appliance when the venting system does not meet these requirements.
- Vinyl protection kits are suggested for use with vinyl siding.

Figure 6.3 Minimum Clearances for Termination

7 Vent Information and Diagrams

A. Approved Pipe

This appliance is approved for use with Hearth & Home Technologies DVRP and SLP venting system, and requires the use of the PVI-SLP-B system. Conversion to DVP is only allowed at the vent cap for use of the firebrick cap. Refer to Section 16.B for vent component information.

DO NOT mix pipe, fittings or joining methods from different manufacturers.

The pipe is tested to be run inside an enclosed wall. There is no requirement for inspection openings at each joint within the wall.

WARNING! Risk of Fire or Asphyxiation. This appliance requires a separate vent. **DO NOT** vent to a pipe serving a separate solid fuel burning appliance.

WARNING! Risk of Fire! This model requires the use of the PVI-SLP-B power venting system. Failure to use this system could result in overheating and fire.

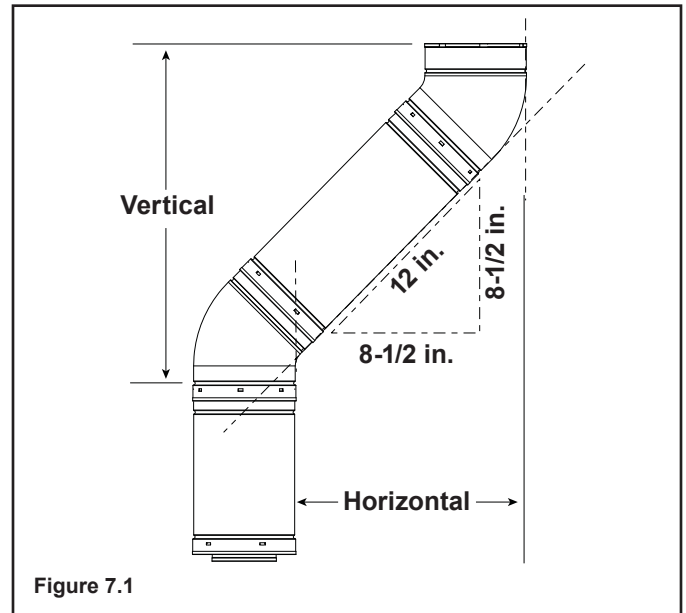

Figure 7.1

B. Vent Table Key

The abbreviations listed in this vent table key are used in the vent diagrams.

Symbol	Description
V ₁	First section (closest to appliance) of vertical length
V ₂	Second section of vertical length
H ₁	First section (closest to appliance) of horizontal length
H ₂	Subsequent sections of horizontal length

C. Use of Elbows

Diagonal runs have both vertical and horizontal vent aspects when calculating the effects. Use the rise for the vertical aspect and the run for the horizontal aspect (see Figure 7.1).

Two 45° elbows may be used in place of one 90° elbow. On 45° runs, one foot of diagonal is equal to 8-1/2 in. (216 mm) horizontal run and 8-1/2 in. (216 mm) vertical run. A length of straight pipe is allowed between two 45° elbows (see Figure 7.1).

D. Measuring Standards

Vertical and horizontal measurements listed in the vent diagrams were made using the following standards.

- Pipe measurements are shown using the effective length of pipe. See Figure 7.2 and Figure 7.3.
- Horizontal terminations are measured to the outside mounting surface (flange of termination cap) (see Figure 6.3).
- Vertical terminations are measured to bottom of termination cap.
- Horizontal pipe installed level with no rise.

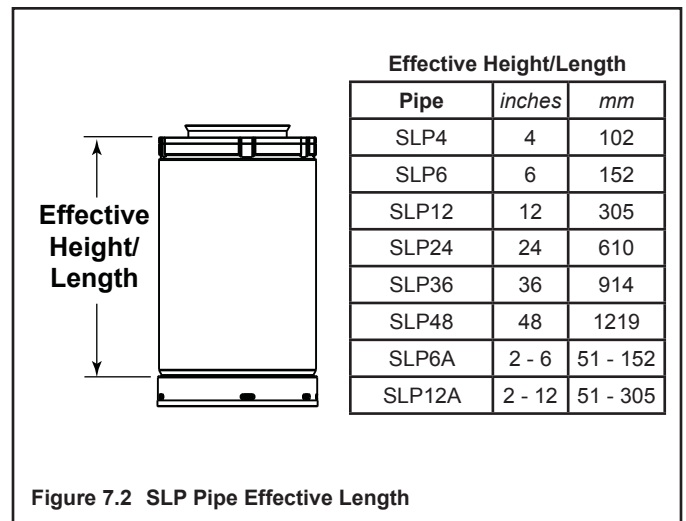

Figure 7.2 SLP Pipe Effective Length

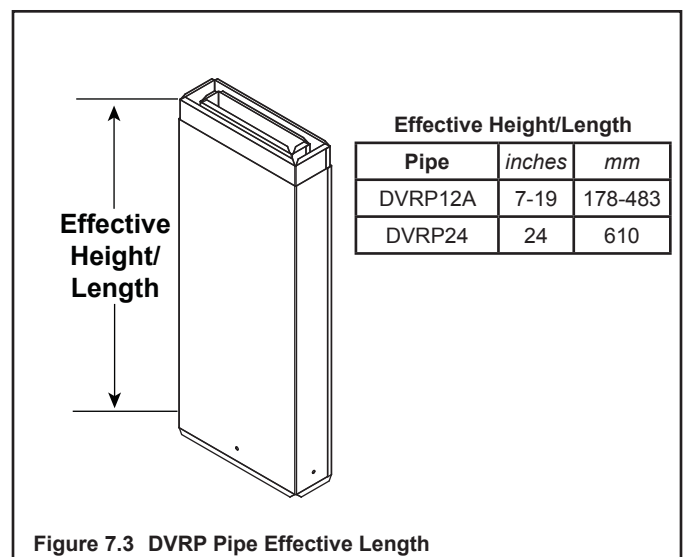

Figure 7.3 DVRP Pipe Effective Length

E. Vent Diagrams

Installation of Vent Pipe

For the allowable pipe lengths and elbow combinations for an appliance utilizing the PVI-SLP-B, see below and on the following pages. The PVI-SLP-B uses SLP pipe (6-5/8 inch) connections for both the inlet and outlet.

The following termination caps are available for use with the power vent inline (PVI-SLP-B): SLP-TVHW, SLP-TRAP, SLP-HRC-SS, SLP-HRC-ZC-SS, DVP-FBHT and LPC-SLP. Check installation manual for termination caps specifications.

All outer pipe joints must be sealed with high temperature silicone, including the slip section that connects directly to the horizontal termination cap.

- Apply a bead of silicone sealant inside the female outer pipe joint prior to joining sections. See Figure 7.4 and 7.5.
- Only outer pipes need to be sealed. All unit collar, pipe, slip section, elbow and cap outer flues shall be sealed in this manner, unless otherwise stated.
- Horizontal termination cap should have a 1/4 inch downward slant to allow any moisture in cap to be released.



Figure 7.4 High Temperature Silicone Sealant

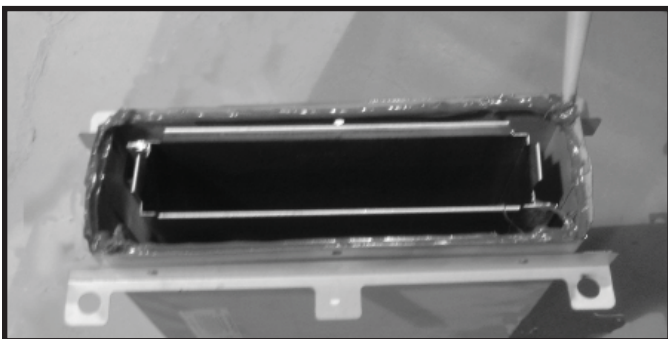
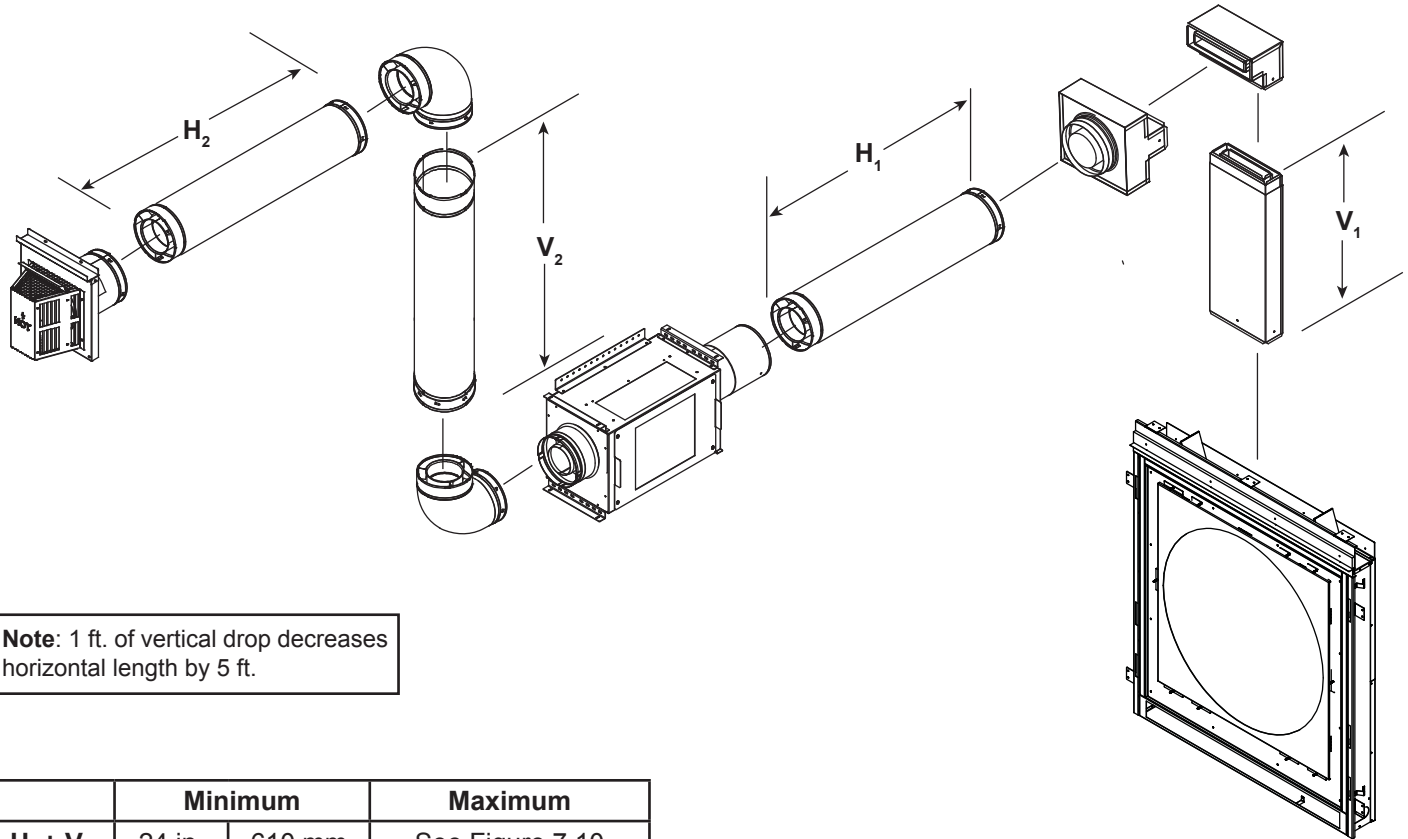

Figure 7.5 High Temperature Silicone Sealant

Vent Pipe Regulations

1. A minimum of one 90 degree elbow and 2 total feet of straight horizontal or straight vertical venting is required between the appliance and the PVI-SLP-B. Once this requirement is met, the PVI-SLP-B may be placed at any point in the venting configuration.
2. A minimum of 18 inches is required between the PVI-SLP-B and the termination cap to allow room for the pipe to go through a wall or roof.
3. If PVI-SLP-B is installed in the vertical position, a minimum of two 90 degree elbows and two feet of pipe are required between the appliance and the PVI-SLP-B. The elbows may be positioned back to back.
4. There may only be a maximum of twelve total feet of DVRP pipe and a maximum of three DVRP elbows.
5. Horizontal length decreases by 5 ft. for every 1 ft. of vertical drop.

Top Vent - Horizontal Termination



Note: 1 ft. of vertical drop decreases horizontal length by 5 ft.

	Minimum		Maximum
$H_1 + V_1$	24 in.	610 mm	See Figure 7.10
H_2	18 in.	457 mm	See Figure 7.10
V_2	0 in.	0 mm	See Figure 7.10

Figure 7.6

Top Vent - Horizontal Termination (continued)

Note: Minimum of two 90 degree elbows required before vertically positioned power vent.

Note: 1 ft. of vertical drop decreases horizontal length by 5 ft.

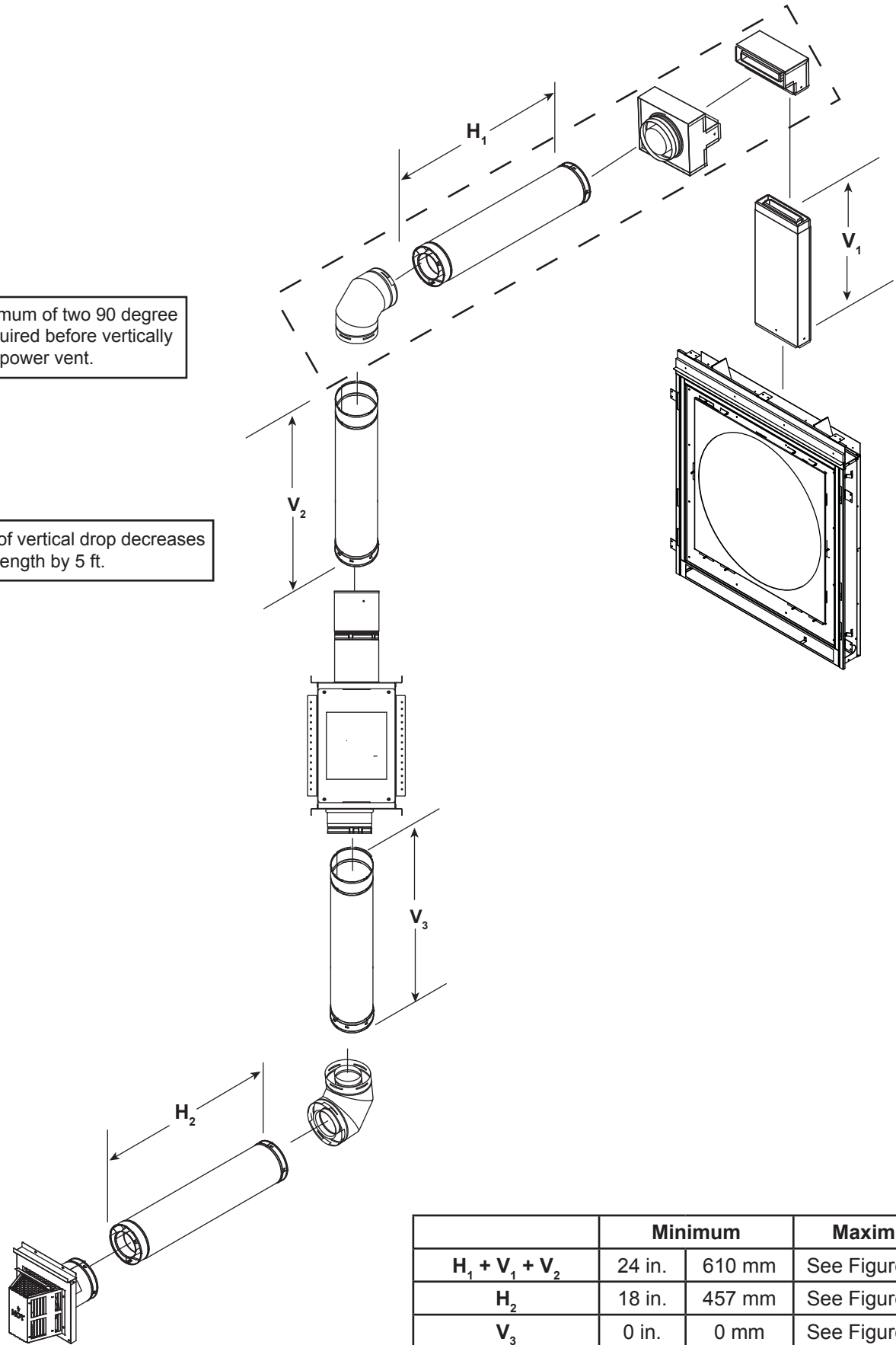

	Minimum		Maximum
$H_1 + V_1 + V_2$	24 in.	610 mm	See Figure 7.10
H_2	18 in.	457 mm	See Figure 7.10
V_3	0 in.	0 mm	See Figure 7.10

Figure 7.7

Top Vent - Horizontal Termination - (continued)

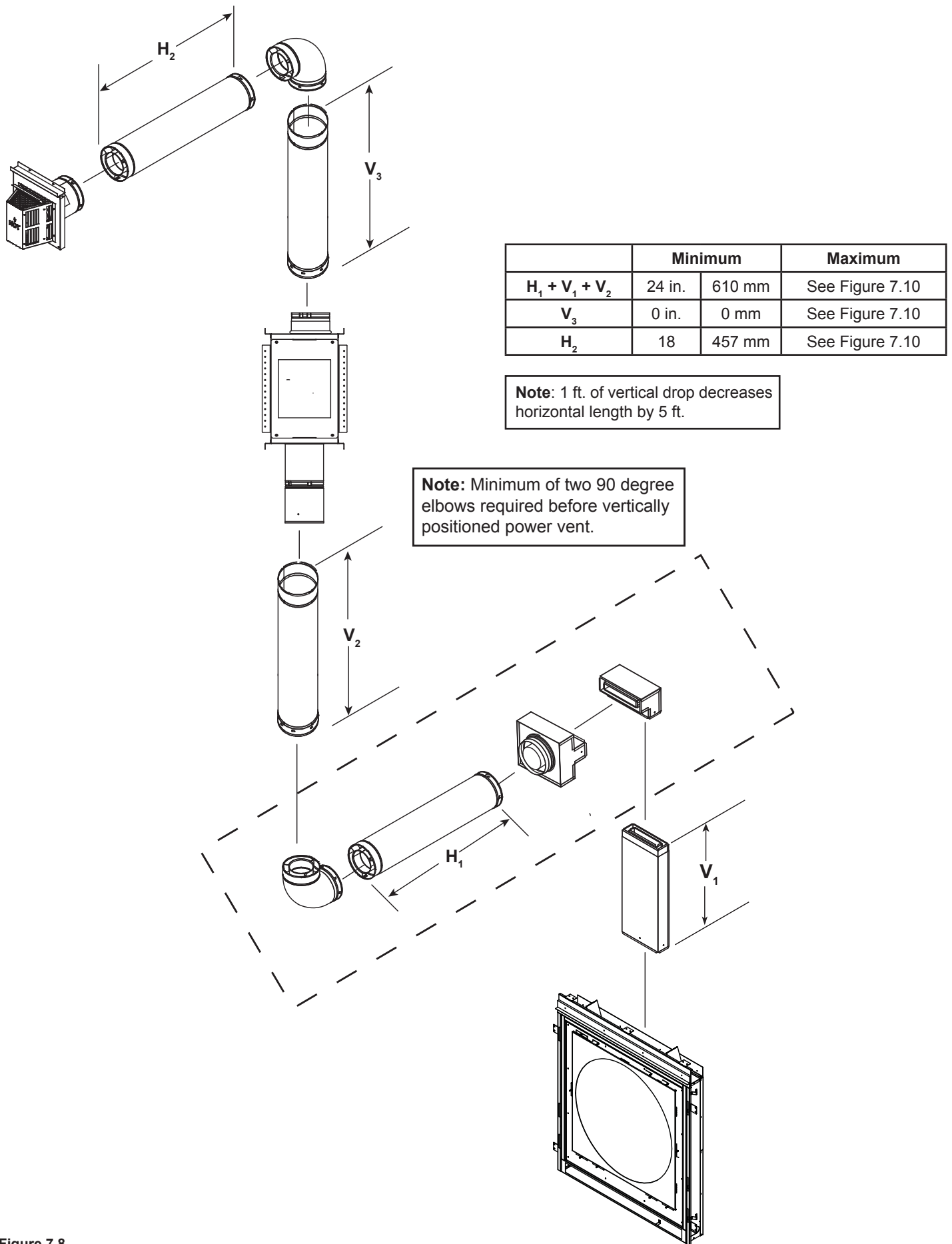

Figure 7.8

Top Vent - Vertical Termination

	Minimum		Maximum
$H_1 + V_1$	24 in.	610 mm	See Figure 7.11
V_2	18 in.	457 mm	See Figure 7.11
H_{TOTAL}	0	0	30% of Total Venting Length allowed in 7.11

Note: 1 ft. of vertical drop decreases horizontal length by 5 ft.

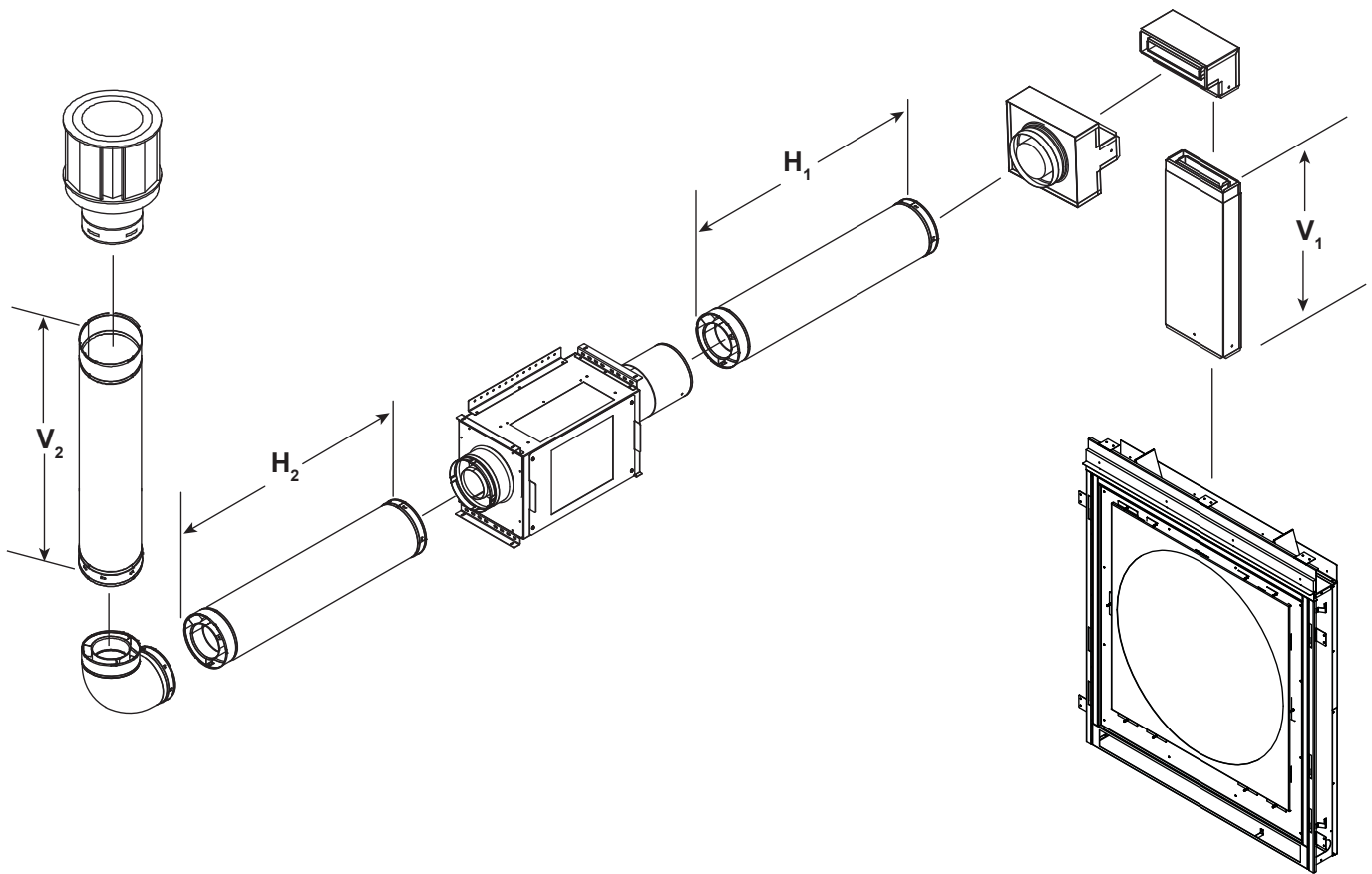

Figure 7.9

Power Vent Inline (PVI-SLP-B)

For the allowable venting configuration of a horizontal termination for this model, refer to Figure 7.10. The shaded boxes containing an “X” are allowable setups.

For the allowable venting configuration of a vertical termination for this model, refer to Figure 7.11. The shaded boxes containing an “X” are allowable setups.

Note: 1 ft. of vertical drop decreases horizontal length by 5 ft.

SOLARIS - Horizontal Termination														
TOTAL VENTING LENGTH (feet)														
# of Elbows	10	20	30	40	50	60	70	80	90	100	110	120	130	140
1	X	X	X	X	X	X	X	X	X	X				
2	X	X	X	X	X	X	X	X	X					
3	X	X	X	X	X	X	X	X	X					
4	X	X	X	X	X	X	X	X	X					
5	X	X	X	X	X	X	X	X						
6	X	X	X	X	X	X	X	X						
7	X	X	X	X	X	X	X	X						
8	X	X	X	X	X	X	X							
9	X	X	X	X	X	X	X							
10	X	X	X	X	X	X	X							
11	X	X	X	X	X	X								
12	X	X	X	X	X	X								
13	X	X	X	X	X	X								

Figure 7.10

SOLARIS - Vertical Termination														
TOTAL VENTING LENGTH (feet)														
Note: Per Figure 7.9, Total H must not exceed 30% of Total Venting Length														
# of Elbows	10	20	30	40	50	60	70	80	90	100	110	120	130	140
2	X	X	X	X	X	X	X	X	X	X	X	X	X	
3	X	X	X	X	X	X	X	X	X	X	X	X		
4	X	X	X	X	X	X	X	X	X	X	X	X		
5	X	X	X	X	X	X	X	X	X	X	X			
6	X	X	X	X	X	X	X	X	X	X				
7	X	X	X	X	X	X	X	X	X	X				
8	X	X	X	X	X	X	X	X	X					
9	X	X	X	X	X	X	X	X	X					
10	X	X	X	X	X	X	X	X						
11	X	X	X	X	X	X	X	X						
12	X	X	X	X	X	X	X							
13	X	X	X	X	X	X	X							

Figure 7.11

8 Vent Clearances and Framing

A. Pipe Clearances to Combustibles

WARNING! Risk of Fire! Maintain air space clearance to vent. DO NOT pack insulation or other combustibles:

- Between ceiling firestops
- Between wall shield firestops
- Around vent system

Failure to keep insulation or other material away from vent pipe may cause over heating and fire.

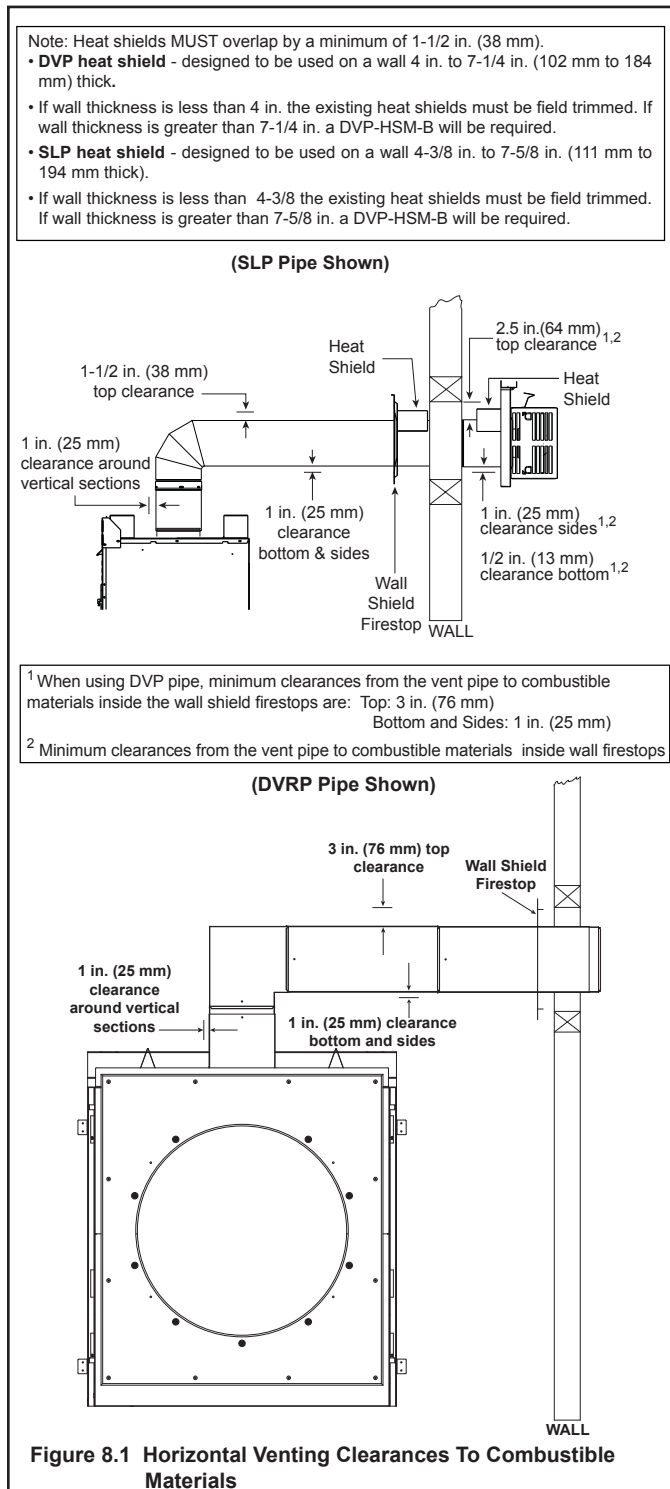

B. Wall Penetration Framing

Combustible Wall Penetration

Whenever a combustible wall is penetrated, you must frame a hole for the wall shield firestop(s). The wall shield firestop maintains minimum clearances and prevents cold air infiltration.

- The opening must be framed on all four sides using the same size framing materials as those used in the wall construction.
- DVRP - A wall shield firestop must be placed on at least one side of the interior wall.
- SLP pipe - A wall shield firestop must be placed on each side of an interior wall. A minimum 1-1/2 in. (38 mm) overlap of attached heat shields must be maintained.
- See Section 10.M. for information for regarding the installation of a horizontal termination cap.

Non-Combustible Wall Penetration

If the hole being penetrated is surrounded by noncombustible materials such as concrete, a hole with diameter one inch greater than the pipe is acceptable.

Whenever a non-combustible wall is penetrated, the wall shield firestop is only required on one side and no heat shield is necessary.

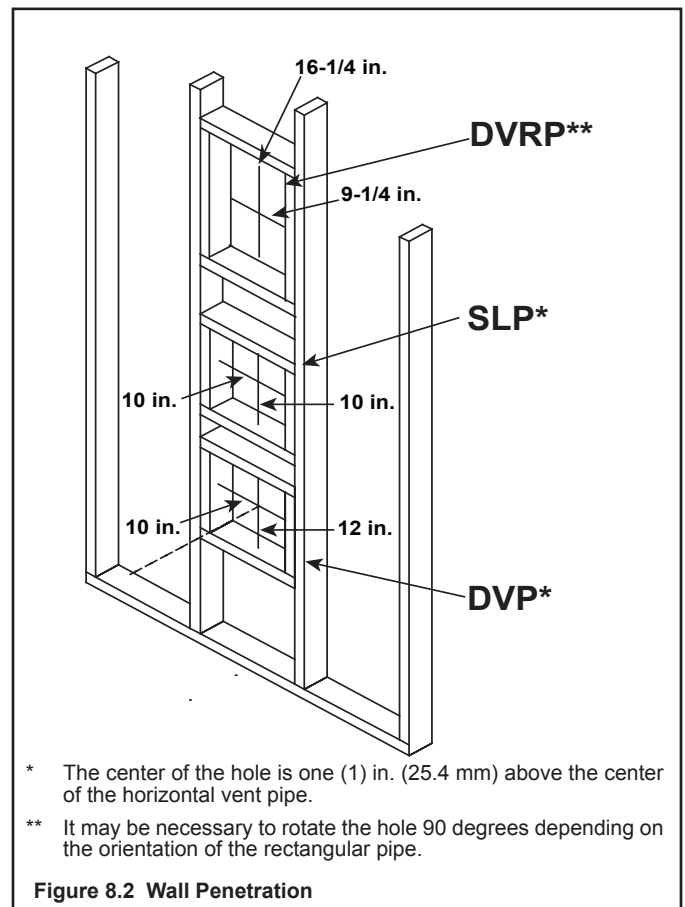

C. Install PVI-SLP-B

Installation Precautions

- a. This device must be installed by a qualified installer in accordance with these instructions.
- b. Safety inspection of the venting system should be performed before and after installation of this power vent. Consult local code officials and follow applicable installation codes.
- c. **DO NOT INSTALL DAMAGED EQUIPMENT OR VENT COMPONENTS.**
- d. Disconnect electrical power supply before making wiring connections.
- e. Venting of more than one appliance in a common vent system is prohibited.
- f. Clearances between the vent pipe and combustible materials must be maintained at least 1-1/2 inch on top, and 1 inch sides and bottom for SLP and 3 inches on top and 1 inch on sides and bottom for DVRP. These clearances apply through entire vent run.
- g. All outer pipe joints must be sealed with high temperature silicone. See Section 7.E.
- h. The access panel opening must be located such that access for service and adjustment is available. The NEC requires a minimum of 30 inches of space around the opening and 36 inches in front of the opening to the access panel. Consult officials having jurisdiction regarding regional requirements.

CAUTION: *Failure to install, operate, and maintain the power venting system in accordance with manufacturer's instructions will result in conditions which may produce bodily injury and/or property damage.*

Installation Guidelines

WARNING: RISK OF FIRE AND BURNS. DO NOT install PVI-SLP-B with the access panel facing upward. Overheating may occur.

NOTICE: *Installation of the PVI-SLP-B in an attic is not recommended in regions where temperatures reach 0°F (-18°C) and relative humidity exceeds 60% simultaneously. Low temperatures and high moisture content may cause the PVI-SLP-B to freeze.*

- a. If the PVI-SLP-B is being installed in a confined space (such as a utility closet, mechanical room or attic space) with a total volume less than 250 cubic feet, an 8 inch by 16 inch hole will be required directly in front of the access panel. The confined space where the PVI is installed, and the space to which the access hole opens, must add up to at least 250 cubic feet. This hole may be covered with a decorative cover as long as the cover has a minimum of 30% open air. If the PVI-SLP-B is being installed in a space greater than 250 cubic feet the 8 inch by 16 inch access hole is still required, but a solid cover may be used. This also applies to a fireplace chase.

The decorative cover CANNOT be located on an outside wall that is open to the environment.

- b. For installations near loose-fill insulation (such as attics) a minimum clearance of six inches must be maintained between the access panel and the insulation.
- c. The PVI-SLP-B CANNOT be installed with the access panel facing upward.
- d. The exit termination of mechanical draft systems shall not be less than seven feet above grade when located adjacent to public walkways.
- e. A mechanical drafting venting system shall terminate at least three feet above any forced air inlet located within 10 feet.

Note: The mounting brackets must be used to install the PVI-SLP-B so that it is secure.

Chassis Dimensions

The dimensions are measured as shown in Figure 8.9 and listed in Table 8.1 when the PVI-SLP-B is vertically positioned.

Height	Width	Depth
18-7/8 in.	11-5/8 in.	10-1/2 in.

Table 8.1.

Framing Dimensions

WARNING! Risk of fire and burns! DO NOT install PVI-SLP-B with the access panel facing upward. Overheating may occur.

Table 8.2 and Figure 8.9 show the clearances required for the PVI-SLP-B. Required clearances are the same for all allowable PVI-SLP-B orientations.

Height	Width	Depth
20-7/8 in.	13-5/8 in.	12 in.

Table 8.2.

If the PVI-SLP-B is being installed in a confined space (such as a utility closet, mechanical room or attic space) with a total volume less than 250 cubic feet, an 8 inch by 16 inch hole will be required directly in front of the access panel. The confined space where the PVI is installed, and the space to which the access hole opens, must add up to at least 250 cubic feet. This hole may be covered with a decorative cover as long as the cover has a minimum

of 30% open air. If the PVI-SLP-B is being installed in a space greater than 250 cubic feet the 8 inch by 16 inch access hole is still required, but a solid cover may be used. This also applies to a fireplace chase. See Figure 8.10.

If the PVI-SLP-B is being installed in a space greater than 250 cubic feet, the 8 inch by 16 inch access hole is still required, but a solid cover may be used.

The access panel opening must be located such that access for service and adjustment is available. The NEC requires a minimum of 30 inches of space around the opening and 36 inches in front of the opening to the access panel. Consult officials having jurisdiction regarding regional requirements.

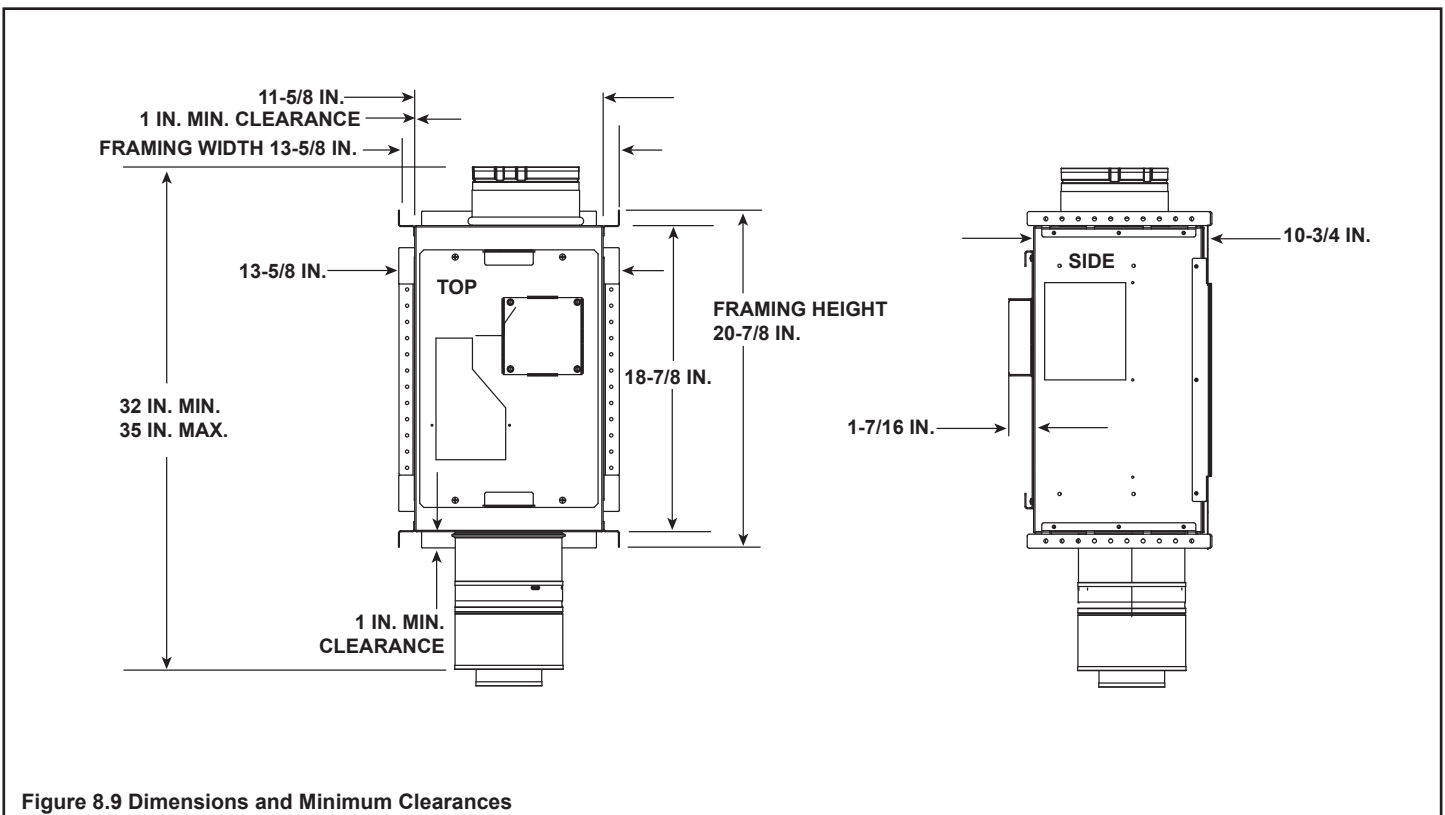
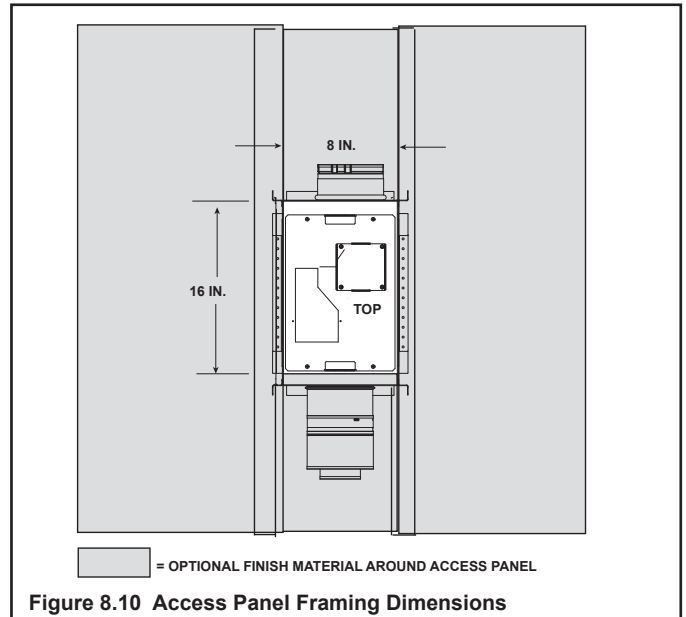

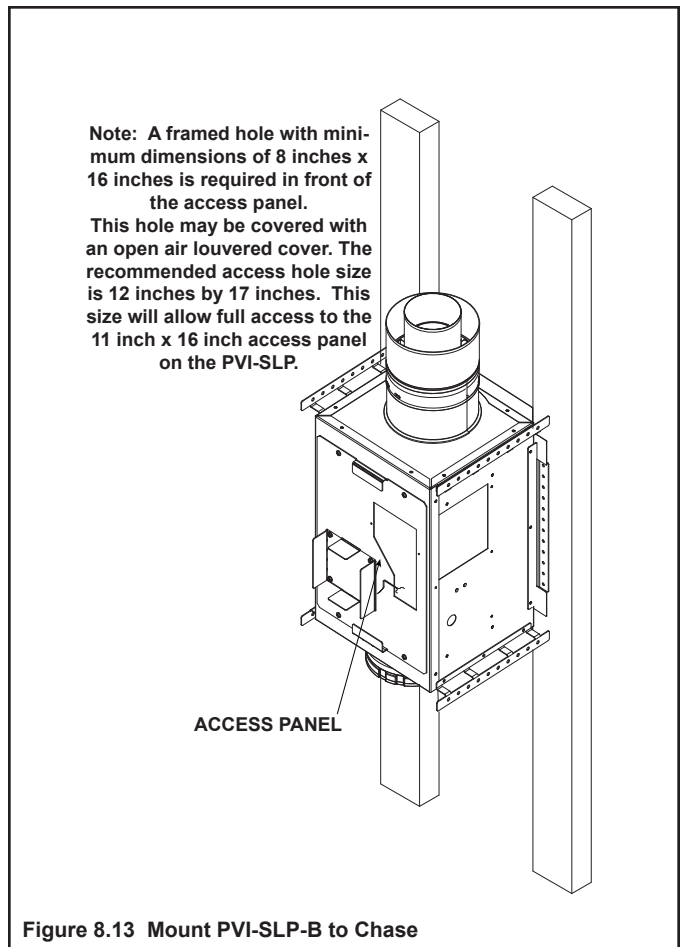
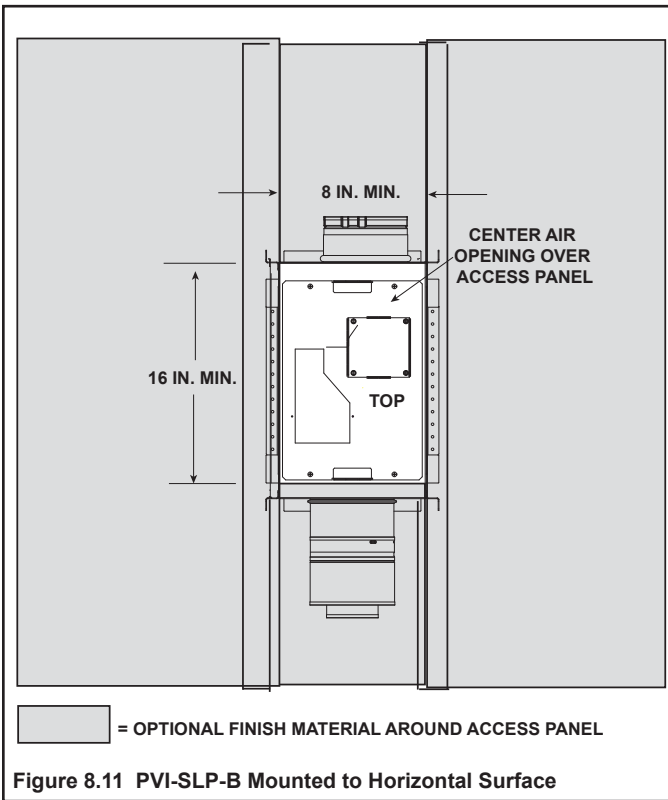

Figures 8.12 - 8.14 show possible framing techniques.

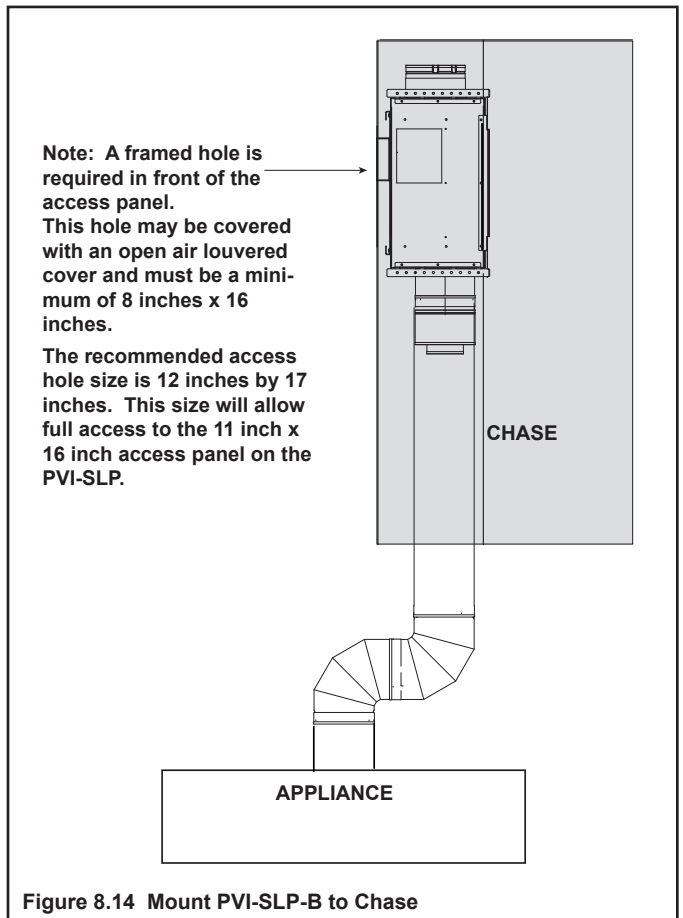
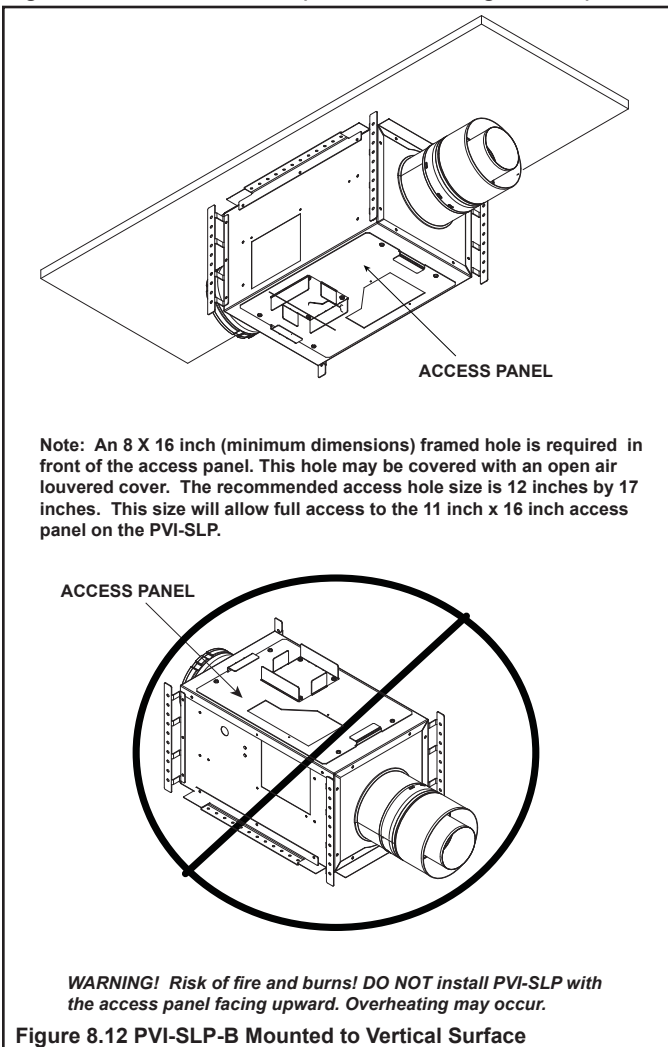

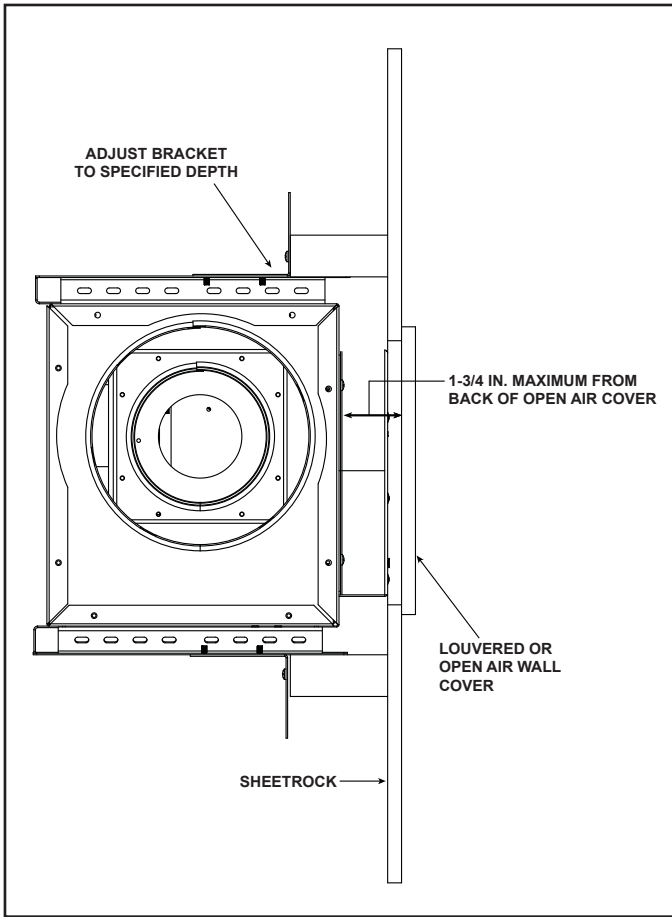

Figure 8.15 PVI-SLP-B Mounted with Fresh Air Access

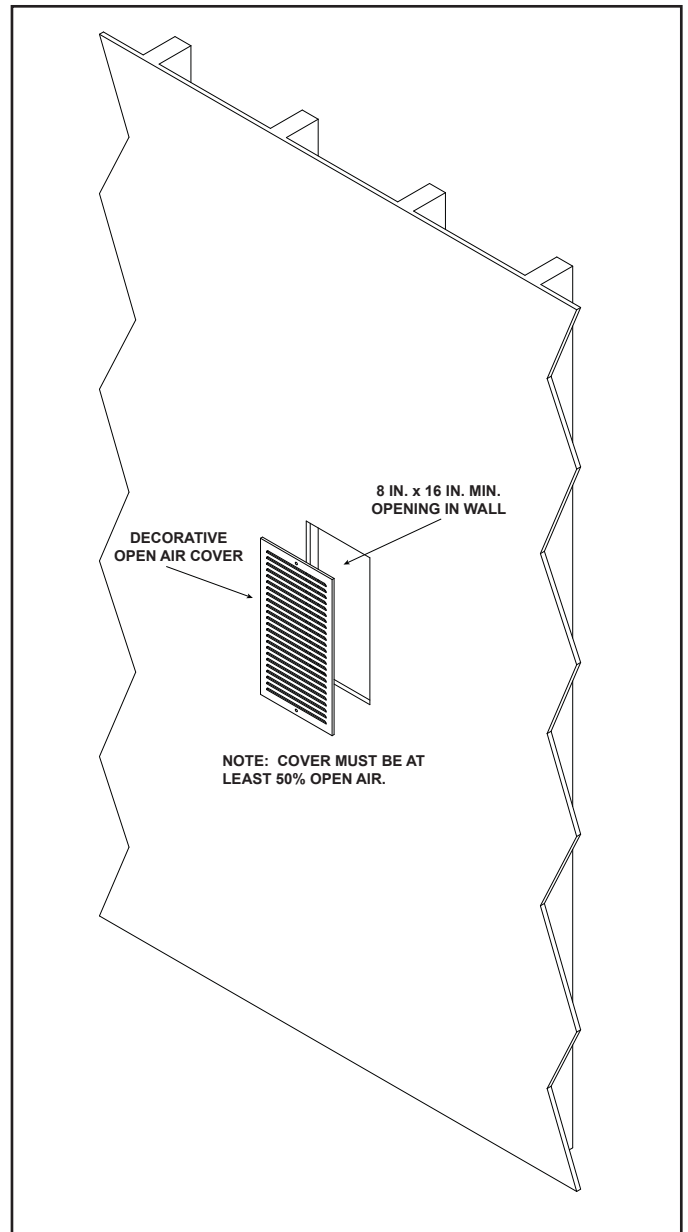

Figure 8.17 Requirements for Decorative Cover Installation

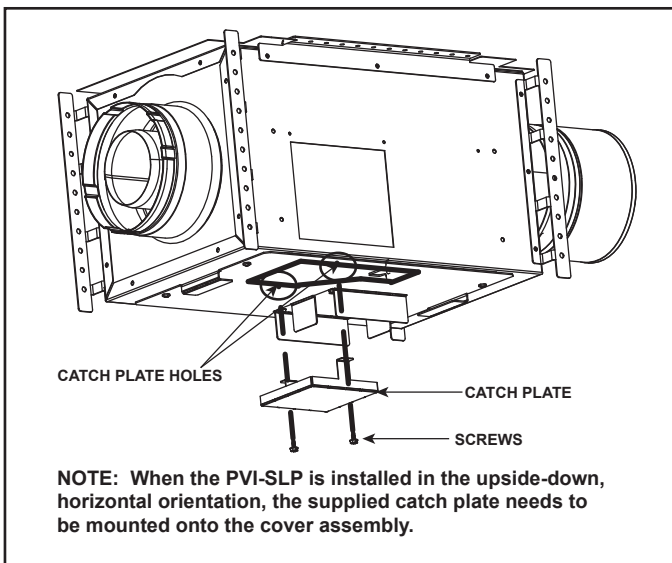

Figure 8.16 Mount the Catch Plate

For additional scenarios to attach the PVI-SLP-B, the optional mounting brackets (2196-024) can be used. They can be secured to the side brackets on the PVI-SLP-B using wing nuts (supplied). The brackets can be attached anywhere along these designated holes. See Figure 8.18 and Figure 8.19.

The optional mounting brackets may be used when mounting the PVI-SLP-B to a studded wall. See Figure 8.20.

Securing the PVI-SLP-B inside a floor joist can be easily done using the side brackets. See Figure 8.21. If the side brackets cannot be used, or additional support is needed, the optional mounting brackets can be used as shown in Figure 8.22.



Figure 8.20

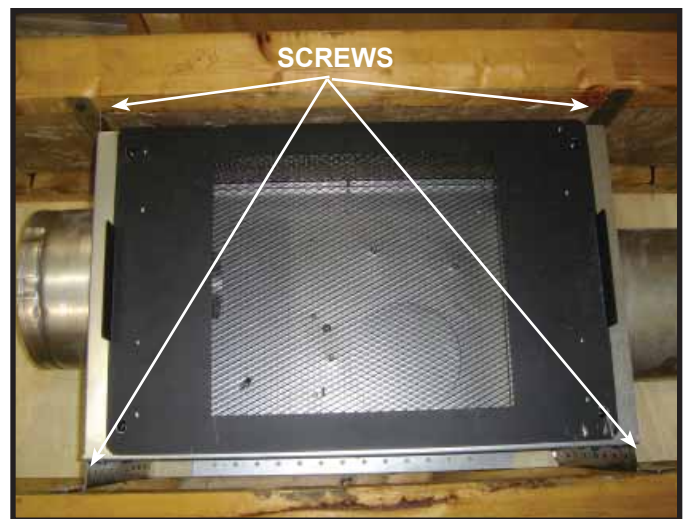

Figure 8.21



Figure 8.22



Figure 8.18



Figure 8.19

D. Install the Ceiling Firestop

A ceiling firestop **MUST** be used between floors and attics.

- **SLP pipe only** - Frame opening 9 in. x 9 in. (229 mm x 229 mm) whenever the vent penetrates a ceiling/floor (see Figure 8.23).
- **DVRP pipe only** - Either the DVRP-CFS or DVRP-WFS may be used as a ceiling firestop for DVRP pipe.
- **DVRP-CFS** - Remove a 12 inch section of the 2 x 6 top wall plate. Attach the firestop with two screws on each side. See Figure 8.24.
- **DVRP-WFS** -Frame opening 9-1/4 in. x 16-1/4 in. (235 mm x 413 mm) whenever the vent penetrates a ceiling/floor. See Figure 8.25.
- Frame the area with the same sized lumber as used in ceiling/floor joist.

- The ceiling firestop may be installed above or below the ceiling joists when installed with a attic insulation shield. It must be under joists between floors that are not insulated. Refer to Figure 8.26.

- Secure with three fasteners on each side.

WARNING! Risk of Fire! DO NOT pack insulation around the vent. Insulation must be kept back from the pipe to prevent overheating.

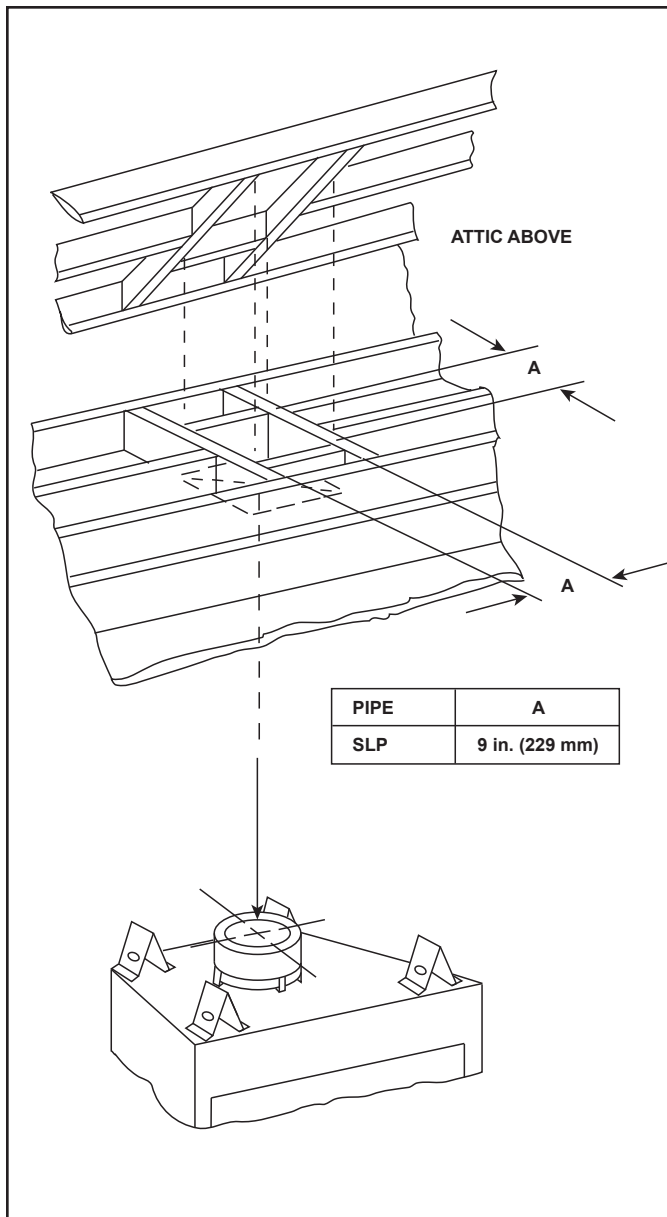

Figure 8.23 Installing Ceiling Firestop

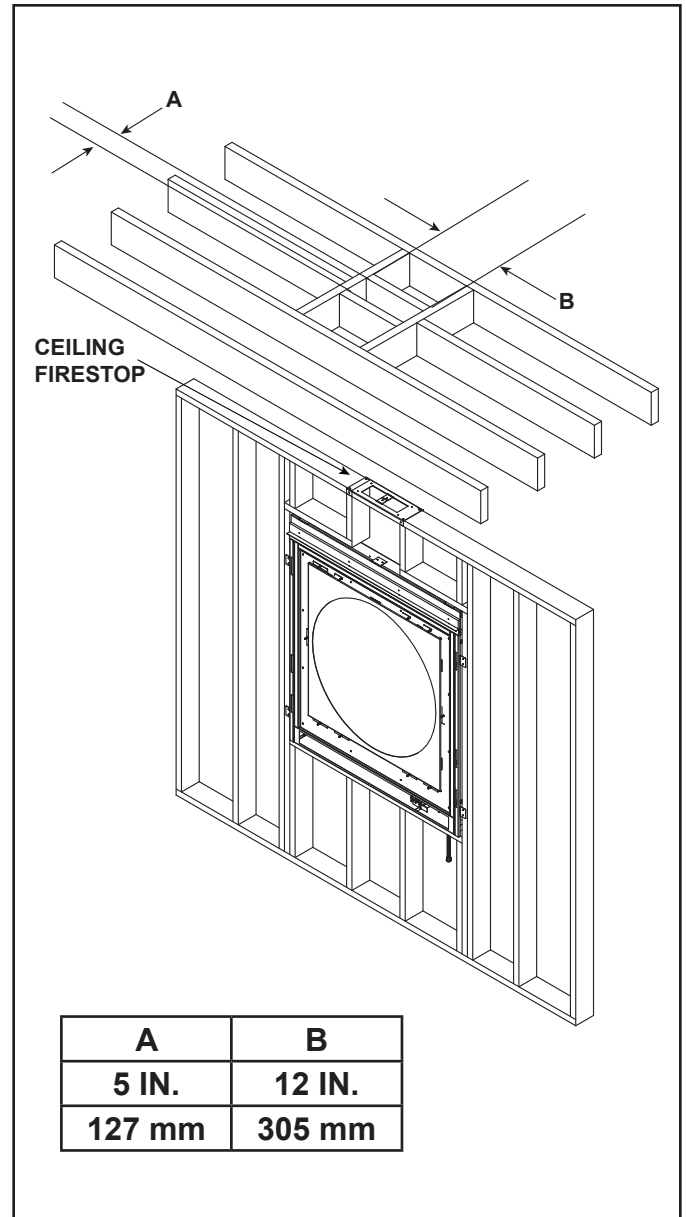

Figure 8.24 Installing DVRP-CFS Firestop

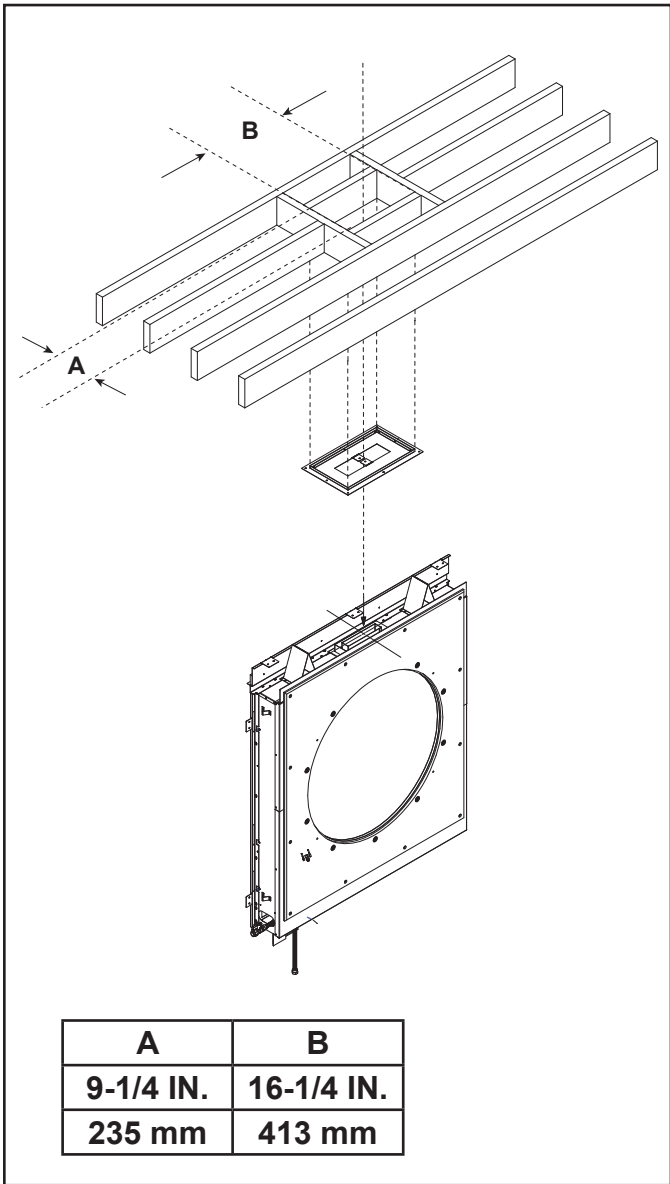

Figure 8.25 Installing DVRP-WFS Ceiling Firestop

E. Install Attic Insulation Shield

WARNING! Fire Risk. DO NOT allow loose materials or insulation to touch vent. *Hearth & Home Technologies requires the use of an attic shield.*

The International Fuel Gas Code requires an attic shield constructed of 26 gauge minimum steel that extends at least 2 in. (51 mm) above insulation.

- Attic insulation shields must meet specified clearances to combustible materials and be secured in place.
- An attic insulation shield kit is available from Hearth & Home Technologies. Contact your dealer to order. Install attic insulation shield according to instructions included with kit.

Flat Ceiling Installation (DVRP Pipe)

- Remove two heat shield component pieces from box.
- **NOTICE:** Cut previously installed batt insulation to make room for the attic insulation shield.
- Place the two pieces around the pipe that has already been installed.
- Align the three holes on each side of the insulation shield and fasten with six screws to form a tube.
- Bend four tabs outward on bottom of shield to allow for attachment to the firestop.
- Bend the remaining tabs inward 90° to maintain the air space between the pipe and shield. Set the shield on the firestop and attach it to the firestop.
- Bend all tabs inward 90° around the top of the shield. These tabs must be used to prevent blown insulation from getting between the shield and vent pipe, and to maintain air space clearance.

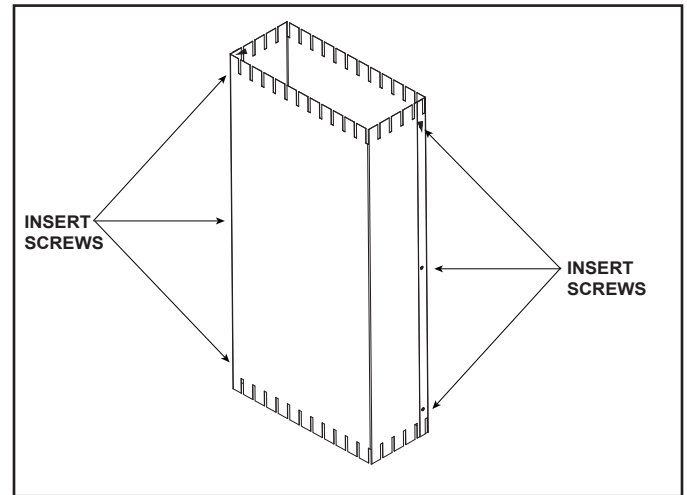

Figure 8.27 Attic Insulation Shield-DVRP

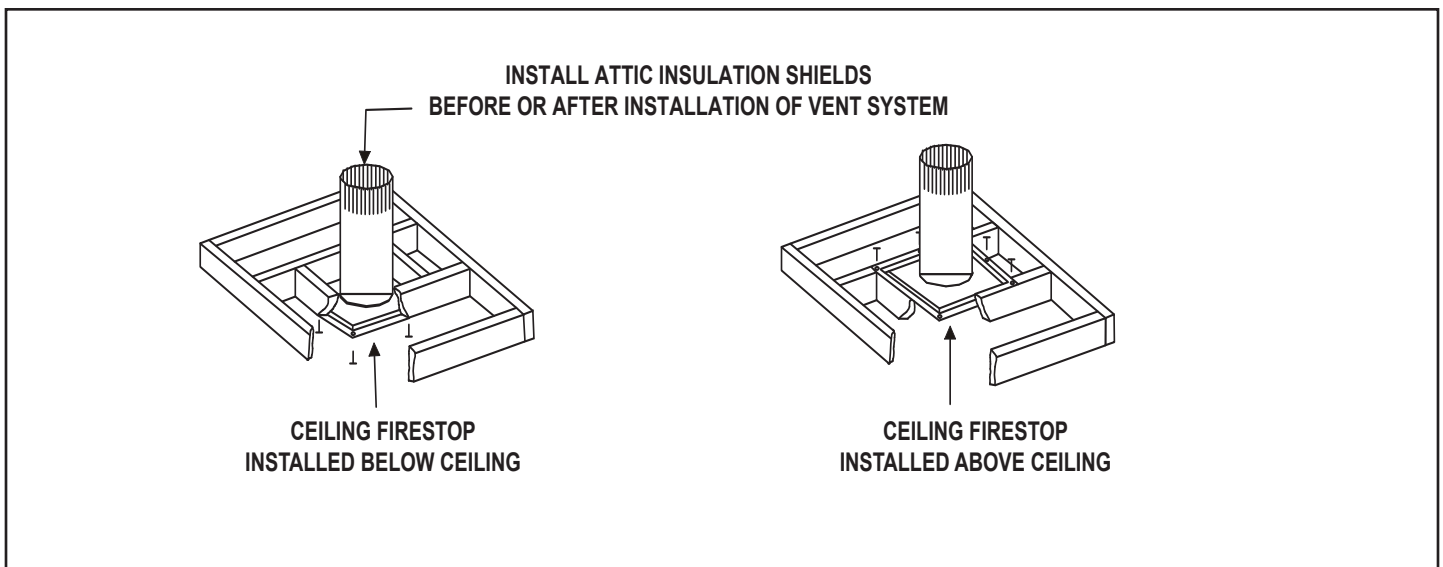

Figure 8.26 Installing the Attic Shield

9 Appliance Preparation

A. Securing and Leveling Appliance

CAUTION! Risk of Cuts, Abrasions or Flying Debris.
Wear protective gloves and safety glasses during installation. Sheet metal edges are sharp.

NOTICE: Once appliance is set up for top or rear venting, it CANNOT be changed at a later time.

The diagram shows how to properly position and secure the appliance (see Figure 9.1). Nailing tabs are provided to secure the appliance to the framing members.

- Bend out nailing tabs on each side.
- Place the appliance into position.
- Keep nailing tabs flush with the framing.
- Level the appliance from side to side and front to back.
- Shim the appliance as necessary. It is acceptable to use wood shims underneath the appliance.
- Secure the appliance to the framing by using nails or screws through the nailing tabs.
- Secure the appliance to the sill by inserting two screws through the pilot holes at the bottom of the appliance.

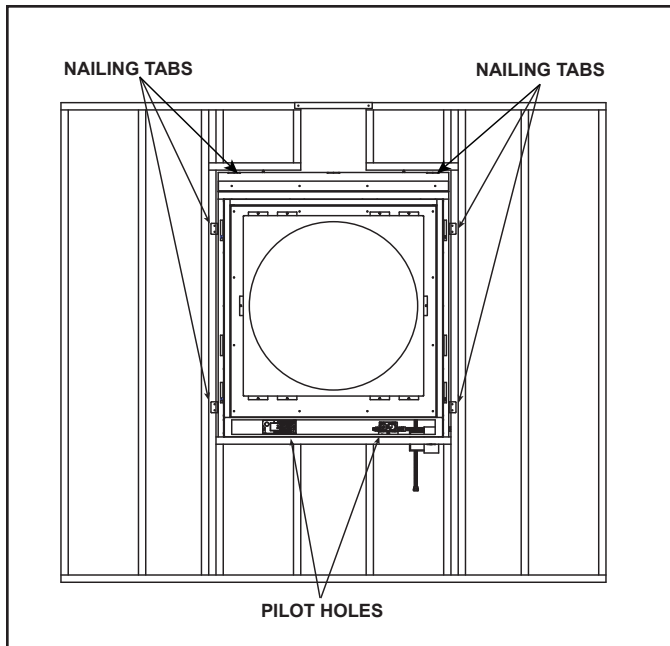

Figure 9.1 Proper Positioning and Securing of an Appliance

10 Installing Vent Pipe (DVRP and SLP Pipe) and PVI-SLP-B

A. Assemble Vent Sections (DVRP Pipe Only)

Attach Vent to the Firebox Assembly

Note: The end of the pipe sections with the outward flare will face toward the appliance.

Attach the first pipe section to the starting collar:

- Flare pipe end over the starting collar
- Inner pipe over inner collar
- Push the pipe section until the pipe is touching the top of the fireplace.
- Attach the pipe to the starting collar with two screws.

All DVRP outer pipe joints must be sealed with high temperature silicone, and foil tape, which is provided with the DVRP-2SLP converter.

- Apply a bead of silicone sealant inside the female outer pipe joint prior to joining sections. See Figure 10.1
- Only outer pipes need to be sealed. All unit collar, pipe, slip section, and elbow shall be sealed in this manner, unless otherwise stated.

WARNING! Risk of Fire or Explosion! DO NOT break silicone seals on slip sections. Use care when removing termination cap from slip pipe. If slip section seals are broken during removal of the termination cap, vent may leak.

Assemble Pipe Sections

Per Figure 10.2:

- Start the inner pipe on the flared end of section A into the chamfered end of section B.
- Start the outer pipe of section A over the outer pipe of section B.
- Once both vents sections are started, push firmly until Section A bottoms out on Section B.
- Attach the sections with four screws.

It is acceptable to use screws no longer than 1/2 in. (13 mm) to hold outer pipe sections together. If predrilling holes, **DO NOT** penetrate inner pipe.

Assemble Adjustable Sections

- Slide the inner section of the adjustable section to the desired length.
- Maintain 1-1/2 inches overlap between the inner and outer sections of the pipe.
- Secure the two pieces of the adjustable section using the two pilot holes provided. Use two screws no longer than 1/2 inch.

NOTICE: If the slip section is too long, the inner and outer flues of the slip section can be cut to the desired length.

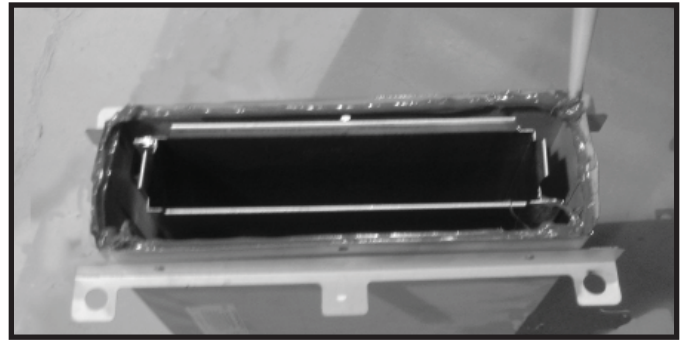

Figure 10.1 High Temperature Silicone Sealant

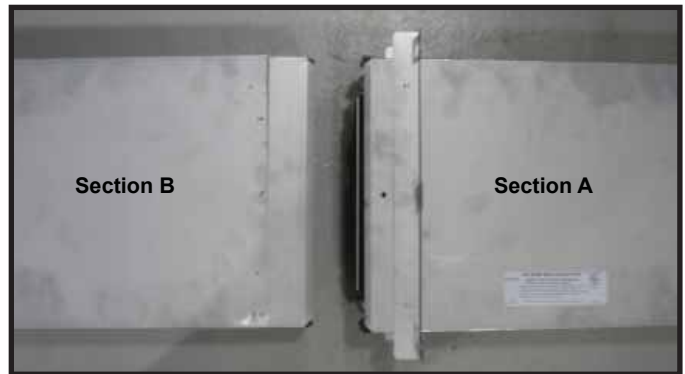

Figure 10.2

Converting DVRP to SLP Vent Sections

- Attach the DVRP-2SLP converter to the last section of DVRP in the same way that you attached the previous DVRP sections.
- Attach the first section of SLP by following the directions in Section 10.B.

B. Assemble Vent Sections (SLP Pipe Only)

- Lock the vent components into place by sliding the pipe section onto the collar.
- Align the seam of the pipe and seam of collar to allow engagement. Rotate the vent component to lock into place. Use this procedure for all vent components. See Figure 10.5.
- Continue adding vent components, locking each succeeding component into place.
- Ensure that each succeeding vent component is securely fitted and locked into the preceding component.

All SOLARIS36 installations require that all outer pipe joints must be sealed with high temperature silicone, including the slip section that connects directly to the horizontal termination cap.

- Apply a bead of silicone sealant inside the female outer pipe joint prior to joining sections. See Figure 10.4.
- Only outer pipes need to be sealed. All unit collar, pipe, slip section, elbow and cap outer flues shall be sealed in this manner, unless otherwise stated.



Figure 10.4 High Temperature Silicone Sealant

WARNING! Risk of Fire or Explosion! DO NOT break silicone seals on slip sections. Use care when removing termination cap from slip pipe. If slip section seals are broken during removal of the termination cap, vent may leak.

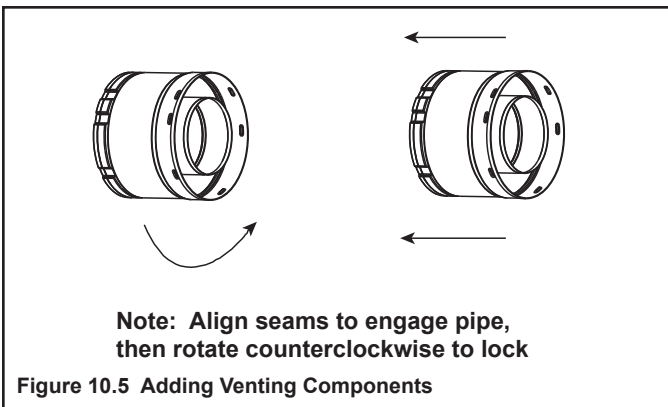

Figure 10.5 Adding Venting Components

C. Assemble Slip Sections

- Slide the inner flue of the slip section into the inner flue of the pipe section and the outer flue of the slip section over the outer flue of the pipe section. See Figure 10.6.
- Slide together to the desired length.

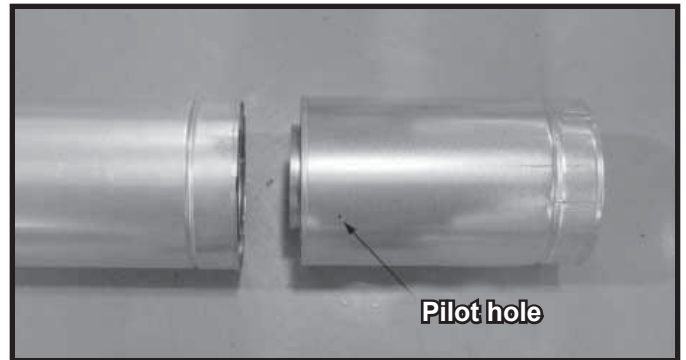

Figure 10.6 Slip Section Pilot Holes

- Maintain a 1-1/2 in. (38 mm) overlap between the slip section and the pipe section.
- Secure the pipe and slip section with two screws no longer than 1/2 in. (13 mm), using the pilot holes in the slip section. See Figure 10.7.

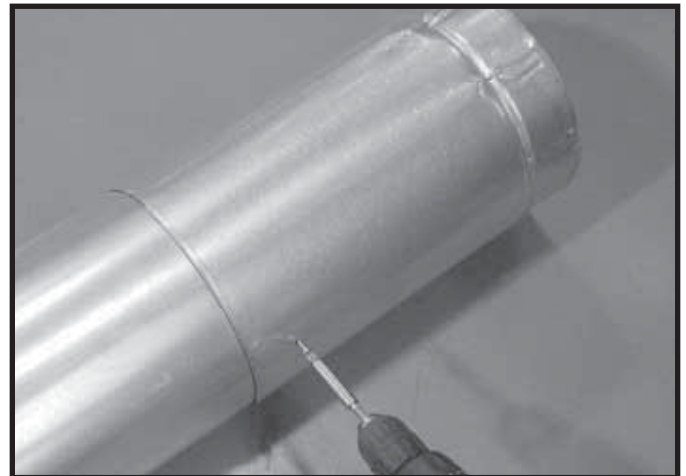

Figure 10.7 Screws into Slip Section

- Continue adding pipe as necessary following instructions in "Assembling Pipe Sections."

NOTICE: If slip section is too long, the inner and outer flues of the slip section can be cut to the desired length.

NOTICE: When installing a vent system with an HRC termination cap, all pipe system joints shall be sealed using a high temperature silicone sealant.

- Apply a bead of silicone sealant inside the female outer pipe joint prior to joining sections.
- Only outer pipes are sealed, sealing the inner flue is not required.
- All unit collar, pipe, slip section, elbow and cap outer flues shall be sealed.

D. Installation of the PVI-SLP-B Power Vent

- Follow the instructions in Section 8.C for proper installation.

E. Secure the Vent Sections

- Vertical runs of SLP pipe must be supported every 8 ft. (2.44 m).
- Horizontal sections must be supported every 5 feet (1.52 m).
- Vertical runs of DVRP pipe must be supported every 6 feet.
- Horizontal runs of DVRP pipe must be supported every 4 feet.
- Vent supports or plumbers strap (spaced 120° apart) may be used to support vent sections. See Figures 10.8 and 10.9.
- Wall shield firestops may be used to provide horizontal support to vent sections.
- SLP ceiling firestops have tabs that may be used to provide vertical support.
- DVRP ceiling firestops have tabs that may be used to provide vertical support.

WARNING! Risk of Fire, Explosion or Asphyxiation! Improper support may allow vent to sag and separate. Use vent run supports and connect vent sections per installation instructions. **DO NOT** allow vent to sag below connection point to appliance.

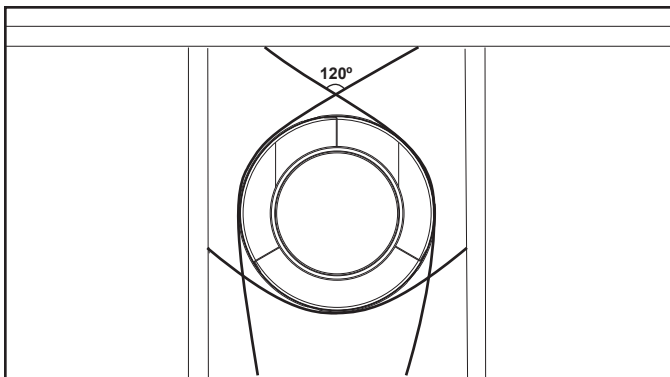

Figure 10.8 Securing Vertical Pipe Sections

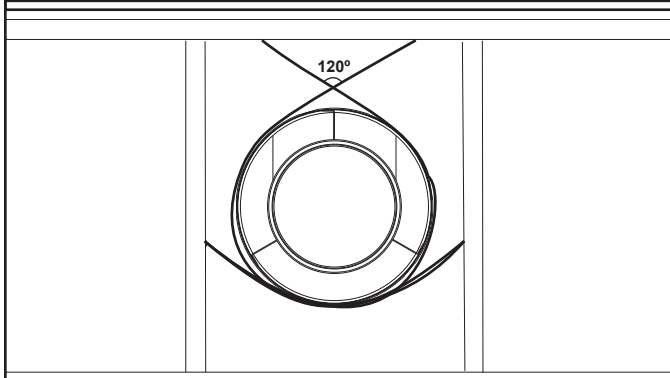

Figure 10.9 Securing Horizontal Pipe Sections

F. Disassemble Vent Sections

- Rotate either section (see Figure 10.10) so the seams on both pipe sections are aligned as shown in Figure 10.11.
- Pull carefully to separate the pieces of pipe.

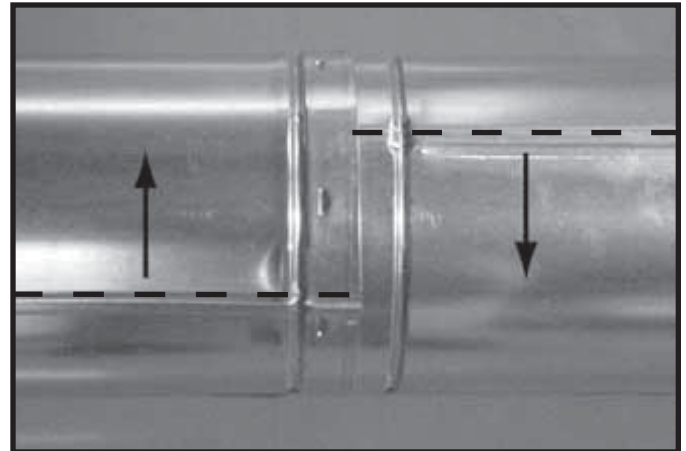

Figure 10.10 Rotate Seams for Disassembly

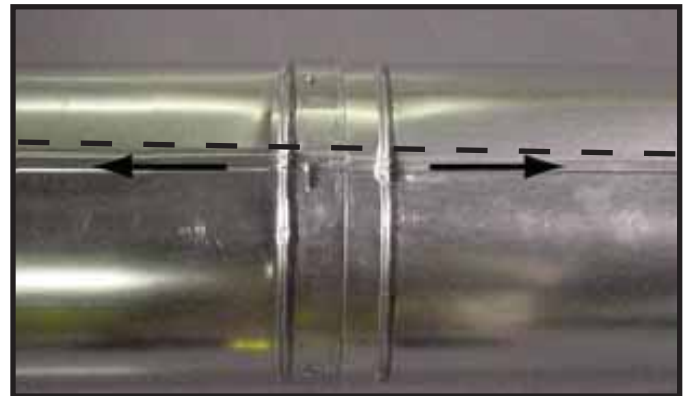

Figure 10.11 Align and Disassemble Vent Sections

G. Install Decorative Ceiling Components (SLP only)

A decorative ceiling thimble can be installed on a flat ceiling through which the vent passes. The decorative ceiling thimble is used to cover the firestop.

- Seal the gap between the vent pipe and firestop using high temperature silicone to prevent cold air infiltration.
- Install the decorative ceiling thimble by sliding it up to the ceiling and attaching it using the provided screws.

A decorative cathedral ceiling support box can be installed on a cathedral ceiling through which the vent passes.

- Use a plumb-bob to mark the center line of the venting system on the ceiling and drill a small hole through the ceiling and roof at this point. Locate the hole and mark the outline of the cathedral ceiling support box on the outside roof.
- Remove shingles or other roof covering as necessary to cut the rectangular hole for the support box. Cut the hole 1/8 in. (3 mm) larger than the support box outline.
- Lower the support box through the hole in the roof until its bottom is at least 2 in. (51 mm) below the ceiling (Figure 10.12).
- Level the support box both vertically and horizontally and temporarily tack it in place through the inside walls into the roof sheathing.
- Use tin snips to cut the support box from the top corners down to the roof line and fold the resulting flaps to the roof. See Figure 10.13.
- Nail the flaps to the roof AFTER running a bead of non hardening sealant between the flaps and the roof.

WARNING! Risk of Fire! Clean out ALL materials from inside the support box and complete the vertical vent run and termination.

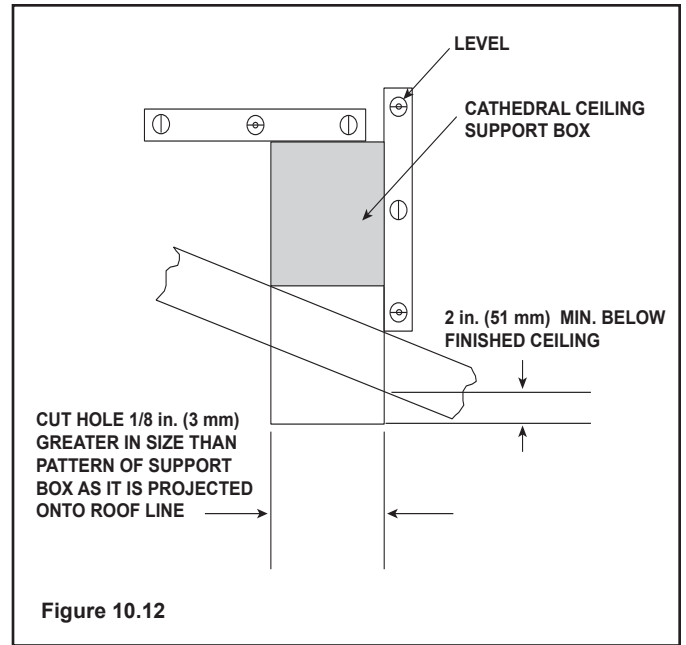

Figure 10.12

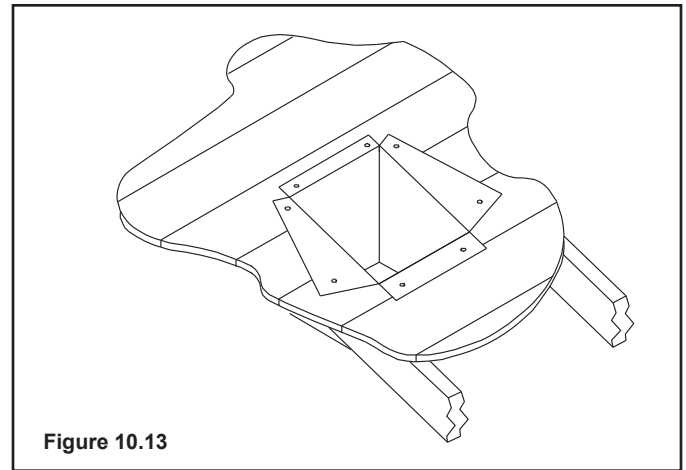
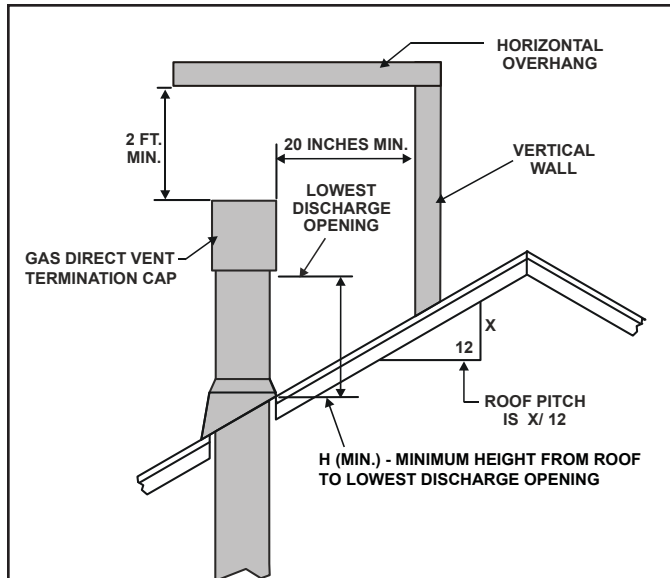

Figure 10.13

H. Install Metal Roof Flashing

- See minimum vent heights for various pitched roofs (Figure 10.14) to determine the length of pipe to extend through the roof.
- Slide the roof flashing over the pipe sections extending through the roof as shown in Figure 10.15.



Roof Pitch	H (Min.) Ft.
Flat to 6/12.....	1.0*
Over 6/12 to 7/12.....	1.25*
Over 7/12 to 8/12.....	1.5*
Over 8/12 to 9/12.....	2.0*
Over 9/12 to 10/12.....	2.5*
Over 10/12 to 11/12.....	3.25
Over 11/12 to 12/12.....	4.0
Over 12/12 to 14/12.....	5.0
Over 14/12 to 16/12.....	6.0
Over 16/12 to 18/12.....	7.0
Over 18/12 to 20/12.....	7.5
Over 20/12 to 21/12.....	8.0

* 3 foot minimum in snow regions

Figure 10.14 Minimum Height From Roof To Lowest Discharge Opening

NOTICE: Failure to properly caulk the roof flashing and pipe seams may permit entry of water.

- Caulk the gap between the roof flashing and the outside diameter of the pipe.
- Caulk the perimeter of the flashing where it contacts the roof surface. See Figure 10.15.
- Caulk the overlap seam of any exposed pipe sections that are located above the roof line.

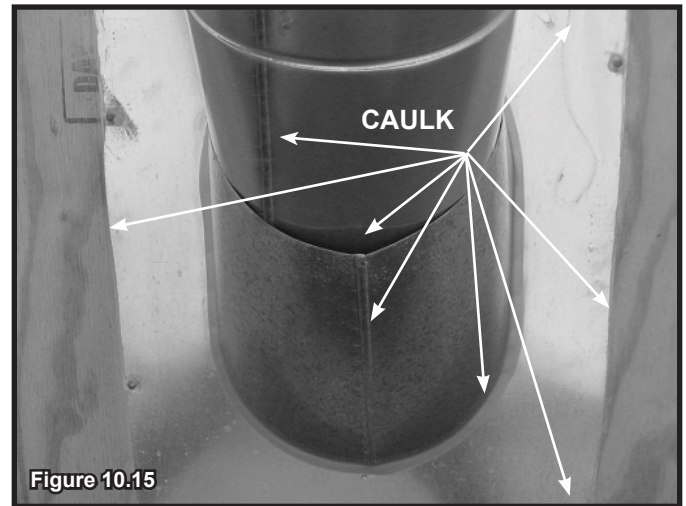

I. Assemble and Install Storm Collar

CAUTION! Risk of Cuts, Abrasions or Flying Debris. Wear protective gloves and safety glasses during installation. Sheet metal edges are sharp.

- Slide the storm collar onto the exposed pipe section and align brackets.
- Insert a bolt (provided) through the brackets and install nut. Do not completely tighten.



- Slide the assembled storm collar down the pipe section until it rests on the roof flashing (see Figure 10.16).
- Tighten nut and make sure the collar is tight against the pipe section.
- Caulk around the top of the storm collar. See Figure 10.17.

J. Install Vertical Termination Cap

- Attach the vertical termination cap by sliding the inner collar of the cap into the inner flue of the pipe section while placing the outer collar of the cap over the outer flue of the pipe section.
- Secure the cap by driving three self-tapping screws (supplied) through the pilot holes in the outer collar of the cap into the outer flue of the pipe (see Figure 10.17).



K. Install Decorative Wall Components (SLP only)

A decorative wall thimble can be installed on wall through which the vent passes. The decorative wall thimble is used to cover the wall shield firestop.

- Slide the decorative wall thimble over the last section of horizontal pipe before connecting the termination cap to the pipe.
- Once the pipe section and the termination cap have been connected, slide the wall thimble up to the interior wall surface and attach with screws provided. See Figure 10.18.

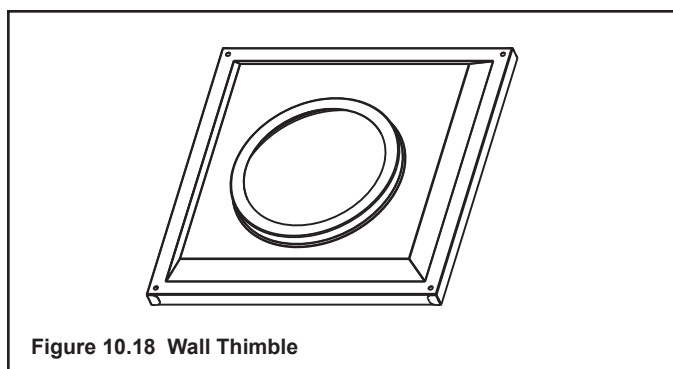

L. Heat Shield Requirements for Horizontal Termination

WARNING! Risk of Fire! To prevent overheating and fire, heat shields must extend through the entire wall thickness.

- **DO NOT** remove the heat shields attached to the wall shield firestop and the horizontal termination cap (shown in Figure 10.19).
- Heat shields must overlap 1-1/2 in. (38 mm) minimum.

There are two sections of the heat shield. One section is factory-attached to the wall shield firestop. The other section is factory-attached to the cap. See Figure 10.19.

If the wall thickness does not allow the required 1-1/2 in. (38 mm) heat shield overlap when installed, an extended heat shield must be used.

- If the wall thickness is less than 4 in./102 mm (DVP) or 4-3/8 in./ 111 mm (SLP), the heat shields on the cap and wall shield firestop must be trimmed. A minimum 1-1/2 in. (38 mm) overlap **MUST** be maintained.
- Use an extended heat shield if the finished wall thickness is greater than 7-1/4 in. (184 mm).
- The extended heat shield may need to be cut to length maintaining sufficient length for a 1-1/2 in. (38 mm) overlap between heat shields.
- Attach the extended heat shield to either of the existing heat shields using the screws supplied with the extended heat shield. Refer to vent components diagrams in the back of this manual.
- Rest the small leg on the extended heat shield on top of the pipe section to properly space it from the pipe section.

Important Notice: Heat shields may not be field constructed.

M. Install Horizontal Termination Cap (DVP and SLP Pipe)

WARNING! Risk of Fire! The telescoping flue section of the termination cap **MUST** be used when connecting vent.

- 1-1/2 (38 mm) minimum overlap of flue telescoping section is required.

Failure to maintain overlap may cause overheating and fire.

- Vent termination must not be recessed in the wall. Siding may be brought to the edge of the cap base.
- Flash and seal as appropriate for siding material at outside edges of cap.
- When installing a horizontal termination cap, follow the cap location guidelines as prescribed by current **ANSI Z223.1** and **CAN/CGA-B149** installation codes and refer to Section 6 of this manual.

CAUTION! Risk of Burns! Local codes may require installation of a cap shield to prevent anything or anyone from touching the hot cap.

NOTICE: For certain exposures which require superior resistance to wind-driven rain penetration, a flashing kit and HRC caps are available. When penetrating a brick wall, a brick extension kit is available for framing the brick.

Note: When using termination caps with factory-supplied heat shield attached, no additional wall shield firestop is required on the exterior side of a combustible wall.

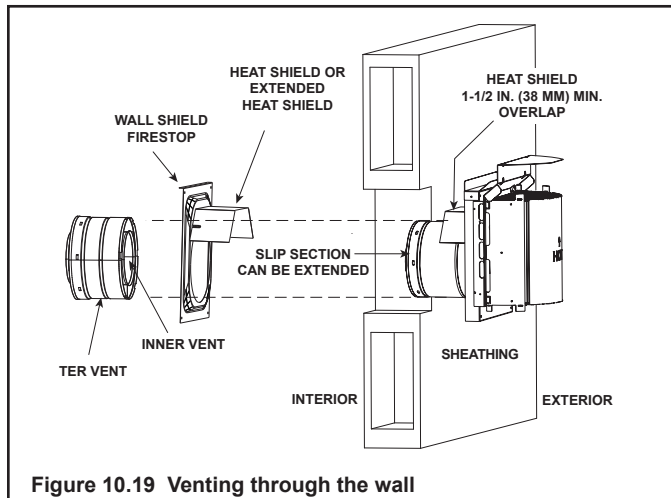

11 Gas Information

A. Fuel Conversion

- Make sure the appliance is compatible with available gas types.
- Conversions must be made by a qualified service technician using Hearth & Home Technologies specified and approved parts.

B. Gas Pressure

- Optimum appliance performance requires proper input pressures.
- Gas line sizing requirements will be determined in ANSI Z223.1 National Fuel Gas Code in the USA and CAN/CGA B149 in Canada.
- Pressure requirements are:

Gas Pressure	Natural Gas	Propane
Minimum inlet pressure	5.0 in. w.c.	11.0 in. w.c.
Maximum inlet pressure	10.0 in. w.c.	13.0 in. w.c.
Manifold pressure	3.5 in. w.c.	10.0 in. w.c.

WARNING! Risk of Fire or Explosion! High pressure will damage valve. Low pressure may cause explosion.

- Verify inlet pressures. Verify minimum pressures when other household gas appliances are operating.
- Install regulator upstream of valve if line pressure is greater than 1/2 psig.

⚠ WARNING



Fire Risk.
Explosion Hazard.
High pressure will damage valve.

- Disconnect gas supply piping BEFORE pressure testing gas line at test pressures above 1/2 psig.
- Close the manual shutoff valve BEFORE pressure testing gas line at test pressures equal to or less than 1/2 psig.

Note: Have the gas supply line installed in accordance with local codes, if any. If not, follow ANSI 223.1. Installation should be done by a qualified installer approved and/or licensed as required by the locality. (In the Commonwealth of Massachusetts installation must be performed by a licensed plumber or gas fitter).

Note: A listed (and Commonwealth of Massachusetts approved) 1/2 in. (13 mm) T-handle manual shut-off valve and flexible gas connector are connected to the 1/2 in. (13 mm) control valve inlet.

- **If substituting for these components, please consult local codes for compliance.**

C. Gas Connection

- Refer to Reference Section 16 for location of gas line access in appliance.
- Gas line may be run through access hole provided or a hole may be made in the bottom of the appliance.
- The gap between supply piping and gas access hole may be caulked with caulk with a minimum of 300°F continuous exposure rating or stuffed with non-combustible, unfaced insulation to prevent cold air infiltration.
- Ensure that gas line does not come in contact with outer wrap of the appliance. Follow local codes.
- Pipe incoming gas line into valve compartment.
- Connect incoming gas line to the 1/2 in. (13 mm) connection on manual shutoff valve.

WARNING! Risk of Fire or Explosion! Support control when attaching pipe to prevent bending gas line.

- A small amount of air will be in the gas supply lines.

WARNING! Risk of Fire or Explosion! Gas build-up during line purge could ignite.

- Purge should be performed by qualified service technician.
- Ensure adequate ventilation.
- Ensure there are no ignition sources such as sparks or open flames.

Light the appliance. It will take a short time for air to purge from lines. When purging is complete the appliance will light and operate normally.

WARNING! Risk of Fire, Explosion or Asphyxiation! Check all fittings and connections with a non-corrosive commercially available leak-check solution. **DO NOT** use open flame. Fittings and connections could have loosened during shipping and handling.

WARNING! Risk of Fire! DO NOT change valve settings. This valve has been preset at the factory.

D. High Altitude Installations

NOTICE: If the heating value of the gas has been reduced, these rules do not apply. Check with your local gas utility or authorities having jurisdiction.

When installing above 2000 feet elevation:

- In the USA: Reduce burner orifice 4% for each 1000 feet above 2000 feet.
- In CANADA: Reduce burner orifice 10% for elevations between 2000 feet and 4500 feet. Above 4500 feet, consult local gas utility.

12 Electrical Information

A. Wiring Requirements

NOTICE: This appliance must be electrically wired and grounded in accordance with local codes or, in the absence of local codes, with **National Electric Code ANSI/NFPA 70-latest edition or the Canadian Electric Code CSA C22.1.**

- Wire the appliance junction box to 110-120 VAC. This is required for proper operation of the appliance.
- A 110-120 VAC circuit for this product must be protected with ground-fault circuit-interrupter protection, in compliance with the applicable electrical codes, when it is installed in locations such as in bathrooms or near sinks.
- Low voltage and 110-120 VAC voltage cannot be shared within the same wall box.

WARNING! Risk of Shock or Explosion! DO NOT wire 110V to the valve or to the appliance wall switch. Incorrect wiring will damage controls.

B. Wall Switch Installation

- A wall switch **MUST** be installed on this appliance. This will allow the appliance to operate.

Wiring for optional Hearth & Home Technologies approved accessories should be done now to avoid reconstruction. Follow instructions that come with those accessories.

Position the wall switch in the desired position on the wall. Instead of the supplied assembly, wire with a length of 25 ft or less and a gauge of 20 AWG through 14 AWG is acceptable. The wire needs a jacket with a temperature rating of 140 °F (60 °C) or higher. At the appliance connect the wire to the ON/OFF switch pigtails.

C. IntelliFire™ Plus Ignition System Wiring

- Wire the appliance junction box to 110-120 VAC for proper operation of the appliance.

WARNING! Risk of Shock or Explosion! DO NOT wire IPI controlled appliance junction box to a switched circuit. Incorrect wiring will override IPI safety lockout.

- Refer to Figure 12.2, IPI Wiring Diagram for the SOLARIS36-ST and SOLARIS36-MR.
- This appliance is equipped with an IntelliFire™ Plus control module which operates on a 6 volt system.
- The ignition module's ON/OFF/REMOTE switch must be in the ON position to work with the wall switch or SMART STAT.
- The control module has safety feature that automatically shuts down the fireplace after 9 hours of continuous operation without receiving a command from the wall switch or optional remote.

Module Reset

This module may lock-out under certain conditions. When this occurs, the appliance will not ignite or respond to commands. The module will go into lock-out mode by emitting three audible beeps, then continuously displaying a RED/GREEN error code at its status indicator LED.

- Locate the module selector switch. (See Figure 12.1).
- Set the module selector switch to the OFF position.
- Wait five (5) minutes to allow possible accumulated gas to clear.
- Set the module selector switch to the ON position.
- Start the appliance.

WARNING! Risk of Explosion! DO NOT press the module reset switch more than one time within a five minute time period. Gas may accumulate in firebox. Call a qualified service technician.

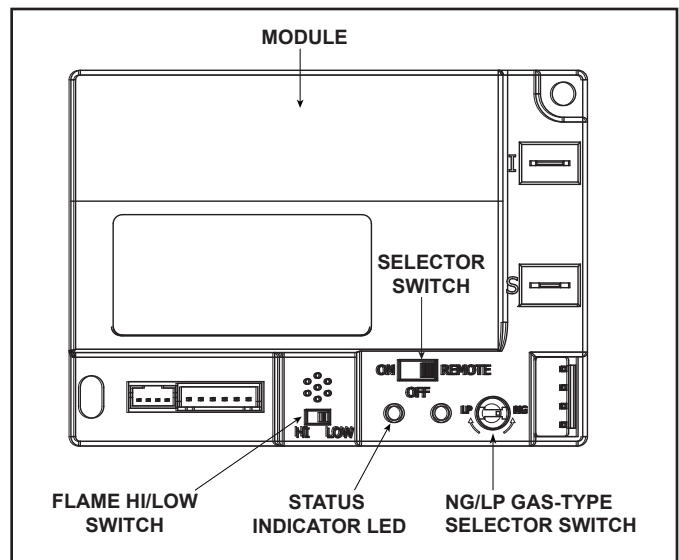

Figure 12.1 Control Module

D. Optional Accessories Requirements

- This appliance comes standard with a wall switch.
- Wiring for optional Hearth & Home Technologies approved accessories should be done now to avoid reconstruction. Follow instructions that come with those accessories.

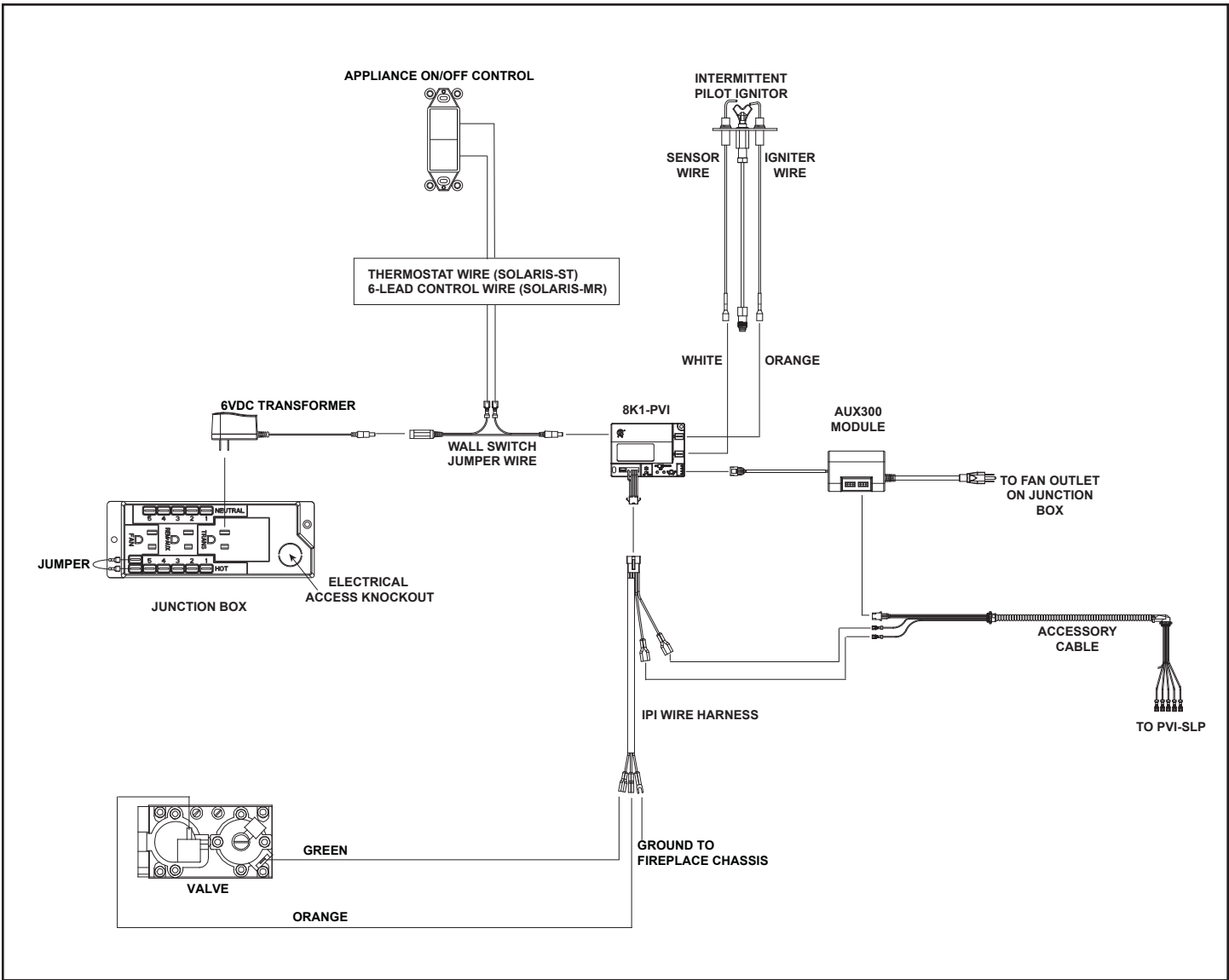

Figure 12.2 IPI Wiring Diagram

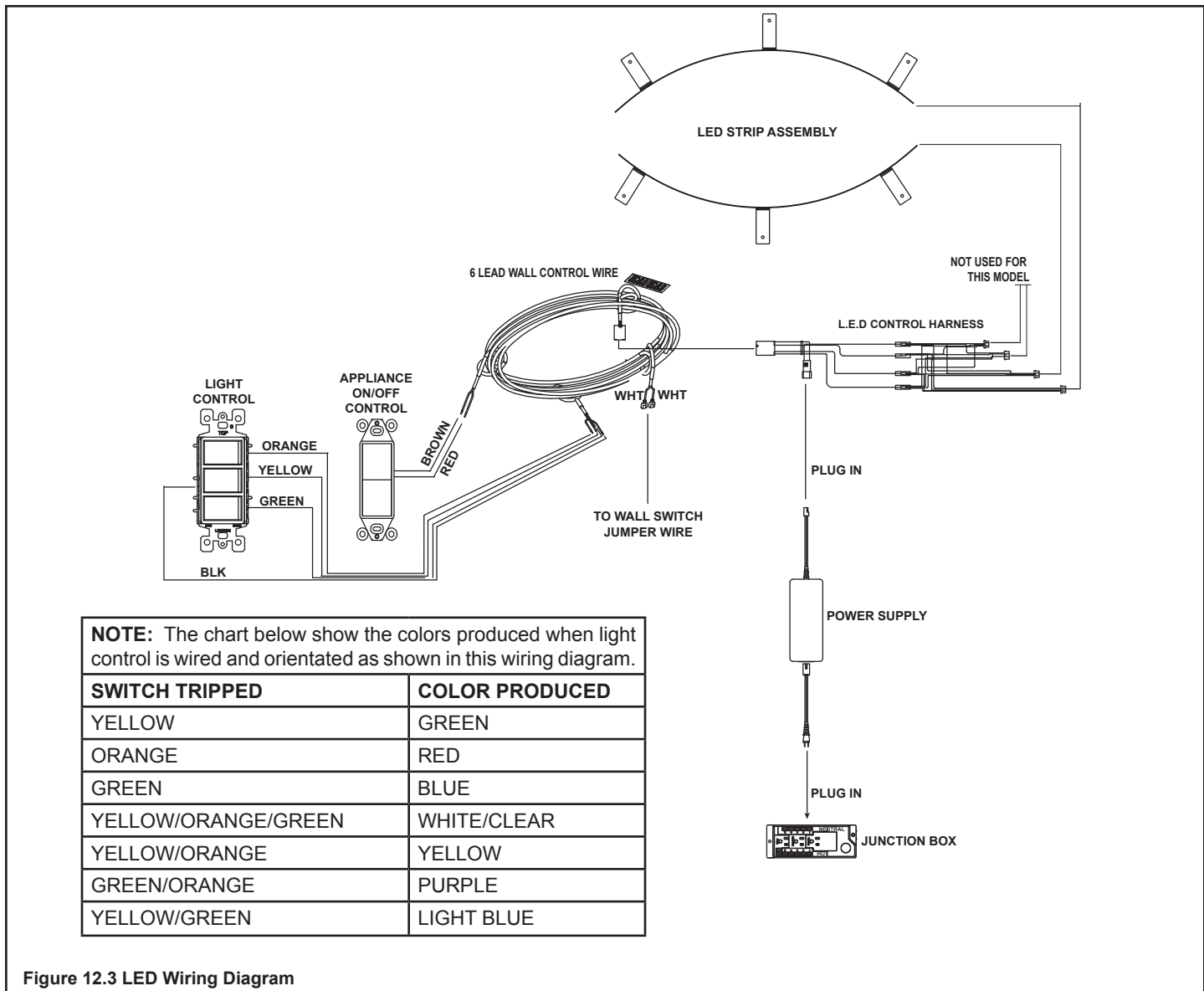

Figure 12.3 LED Wiring Diagram

E. Electrical Service and Repair

WARNING! Risk of Shock! Label all wires prior to disconnection when servicing controls. Wiring errors can cause improper and dangerous operation. Verify proper operation after servicing.

WARNING! Risk of Shock! Replace damaged wire with type 105° C rated wire. Wire must have high temperature insulation.

F. Junction Box Installation

- Remove the screw attaching the junction box/receptacle to the outer shell, rotate the junction box inward to disengage it from the outer shell. See Figure 12.4.
- Pull the electrical wires from outside the appliance through the opening into the valve compartment and secure wires with a Romex connector. See Figure 12.4.
- Remove the knockout from the front of the junction box.
- Pull the electrical wires through the knockout and secure the wires with a Romex connector. See Figure 12.4.

- Make all necessary wire connections to the junction box/receptacle and reattach the junction box/receptacle to the outer shell.

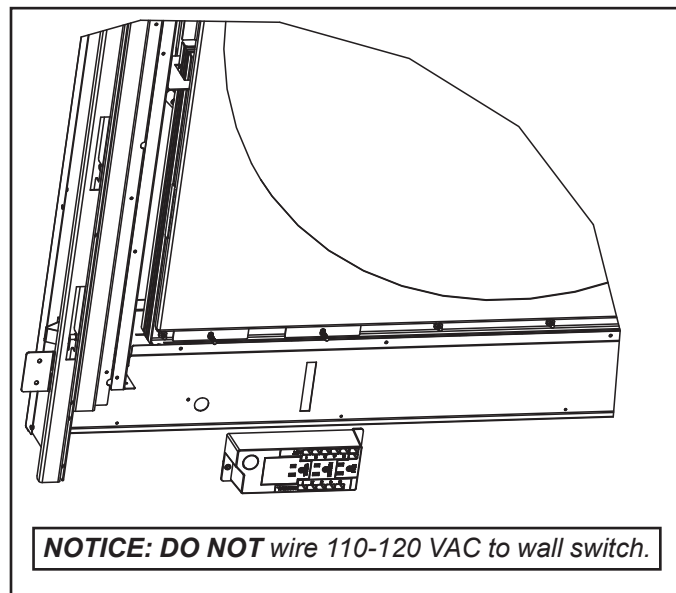

Figure 12.4 Junction Box Detail

G. PVI-SLP-B Wiring

NOTICE: Electrical wiring must be done in accordance with national, provincial, and/or local electric codes.

CAUTION: Risk of shock! Disconnect electrical power from fireplace/power vent before performing any maintenance, repair, or electrical wiring.

NOTICE: Electrical service of 120 VAC-60Hz must be supplied to the junction box of the fireplace in order for the power vent to operate correctly.

1. Wire Harness

- Determine the length of the wire harness required to run between the PVI-SLP-B and the appliance from the service parts list.
- Attach the end of the harness with the loose wires to the PVI-SLP-B. Use supplied wire ties to contain all loose wiring.
- Attach the end of the harness with the connector to the appliance.

2. PVI-SLP-B Connections

Refer to the PVI-SLP-B wiring diagram (Figure 12.5).

- Attach the green wire from the harness to the quick ground connect. Connect the red wire to one of the spades on the vacuum switch. Connect the brown wire to the remaining spade on the vacuum switch.
- Connect the white wire from the harness to the open female connector on harness, part number 2187-198, inside the PVI.
- Connect the black wire from the harness to the open male connector on harness, part number 2187-198, inside the PVI.

3. SOLARIS Connections

Refer to the SOLARIS36-ST and SOLARIS36-MR wiring diagrams, Figure 12.2 and Figure 12.3. Ensure wire harness has been fastened to the appliance. Route wires and wire harness in a manner that protects them from contact with sharp metal surfaces.

- Attach the white, 3-wire connector to the AUX #2 connector on the AUX300.
- Connect the brown wire to the brown wire coming from the 8K1-PVI.
- Connect the red wire to the red wire coming from the 8K1-PVI.

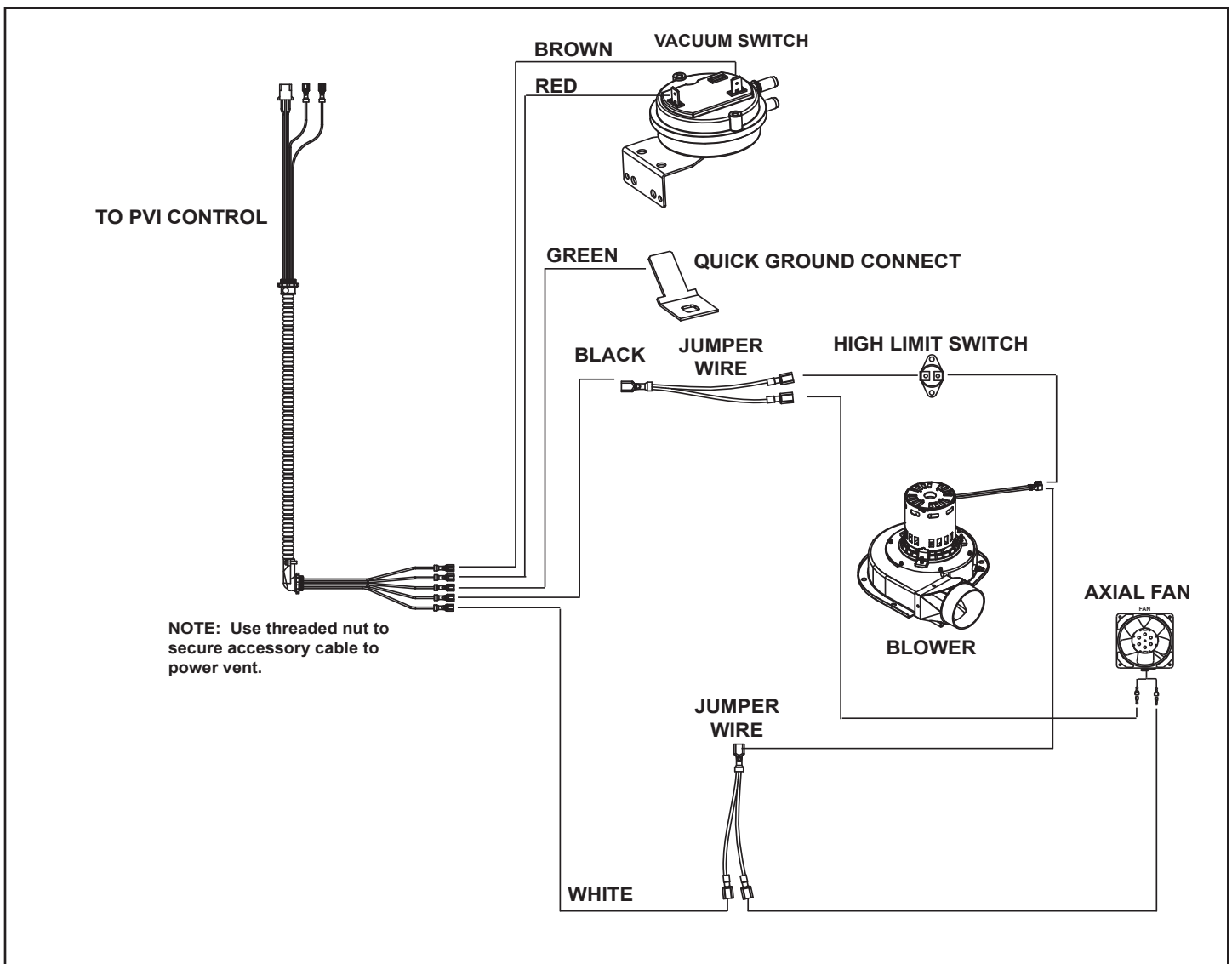

Figure 12.5 Internal PVI Wiring

13 Finishing

WARNING! Risk of Fire! Comply with all minimum clearances as specified. Framing or finishing material closer than the minimums listed must be constructed entirely of non-combustible materials (i.e., steel studs, concrete board, etc).

- Facing and/or finishing materials must not interfere with air flow, operation of decorative front, or access for service.
- Facing and/or finishing materials must never overhang into the glass opening.
- Observe all clearances when applying combustible materials.

WARNING! Risk of Fire! DO NOT apply combustible materials beyond the minimum clearances. Overlapping materials could ignite and will interfere with proper operation of doors.

A. Doors and Finishing - Front Side

Note: The front of the Solaris is the side with access to the controls.

The SOL-BASE with SOL-TB and SOL-LR panels is the only door certified for use on the front of the Solaris fireplace. This door is available in several standard finishes. Custom finishes may be available, see your dealer for details.

When installed as inside fit (finish material or alcove extending around the door), there must be at least one inch clearance on the sides and bottom of the door panels, and 2-1/2 inches clearance on the top of the door panels to permit removal and access to the controls.

Sheath the wall per Figure 13.1.

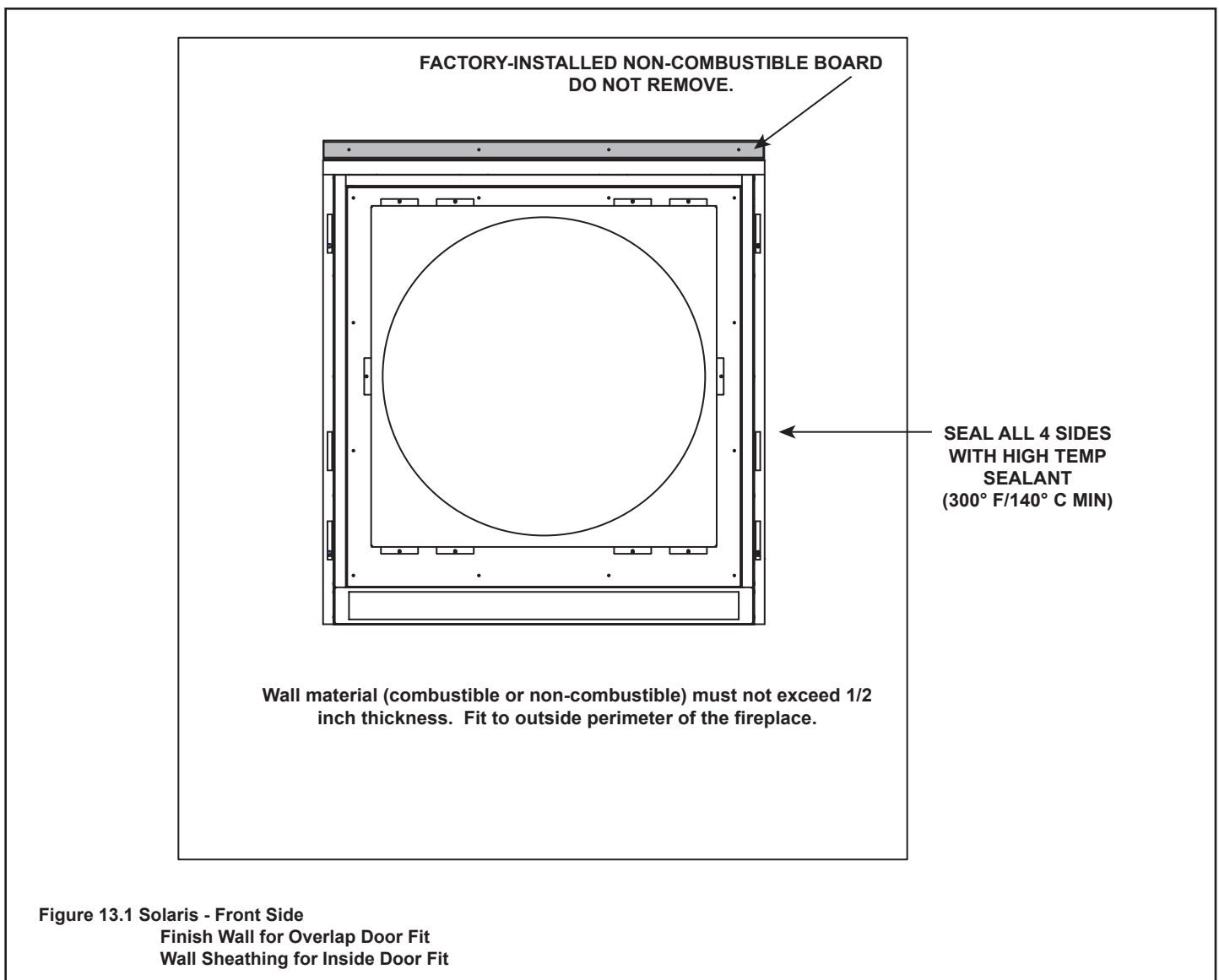

Figure 13.1 Solaris - Front Side
Finish Wall for Overlap Door Fit
Wall Sheathing for Inside Door Fit

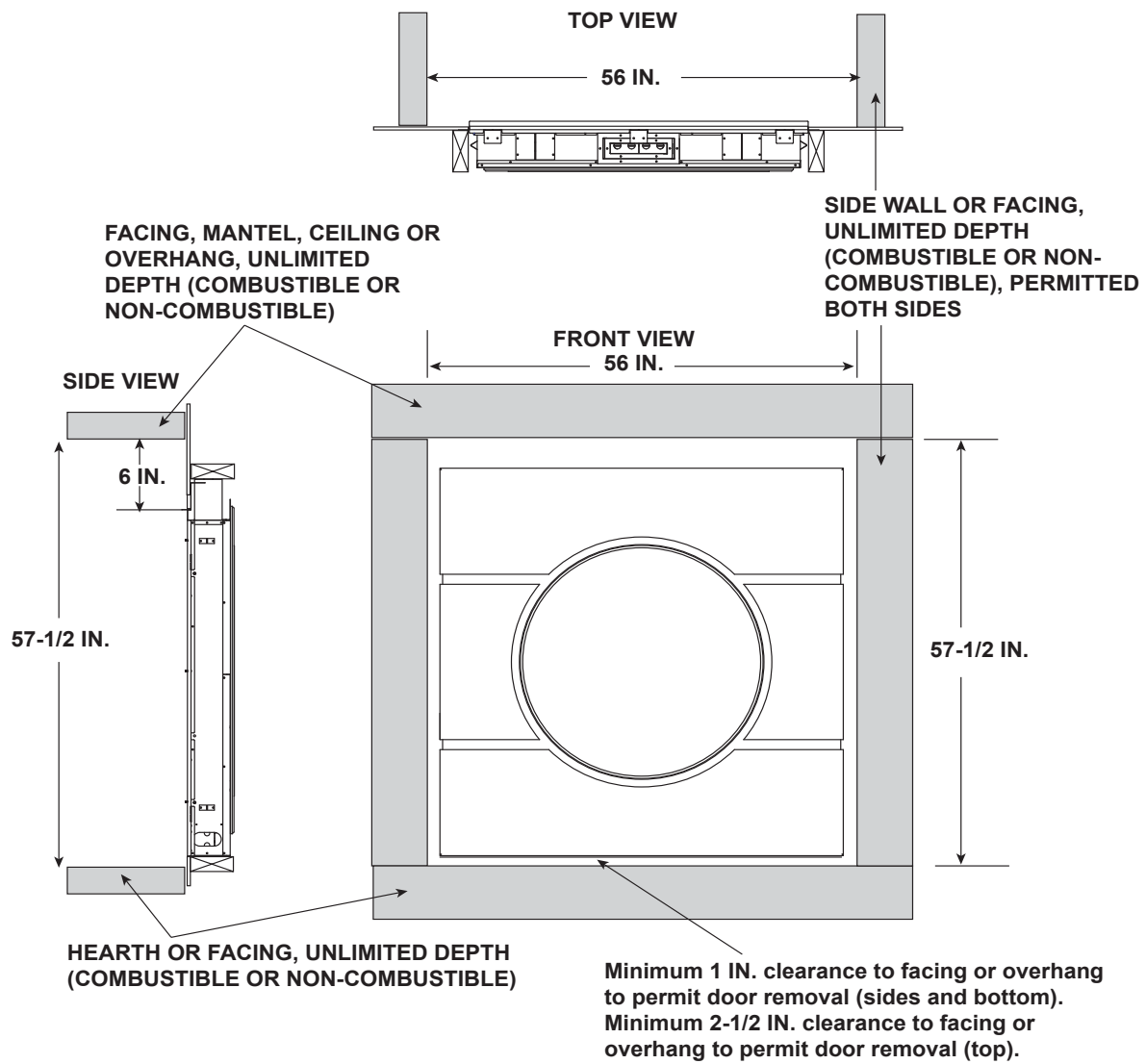

Figure 13.2 Solaris - Front Side
 Finish Wall for Inside Door Fit
 Minimum Alcove, Side Wall, Mantel and Overhang Dimensions

B. Doors and Finishing - Back Side

The SOL-RING series of doors are the only doors certified for use on the back of the Solaris fireplace. They may be mounted for either inside fit or overlap fit.

Non-combustible wall material is supplied, thickness is $\frac{1}{2}$ in. It may be made up to $\frac{7}{8}$ in. thicker with non-combustible material, to a maximum of $1\frac{3}{8}$ in. (See Figure 13.6 regarding maximum screw length for attachment.)

The supplied non-combustible boards may be surrounded with combustible wall material (such as sheet rock).

SEAL ALL 4 SIDES WITH
HIGH TEMPERATURE SEALANT
(300°F/149° C MIN.)

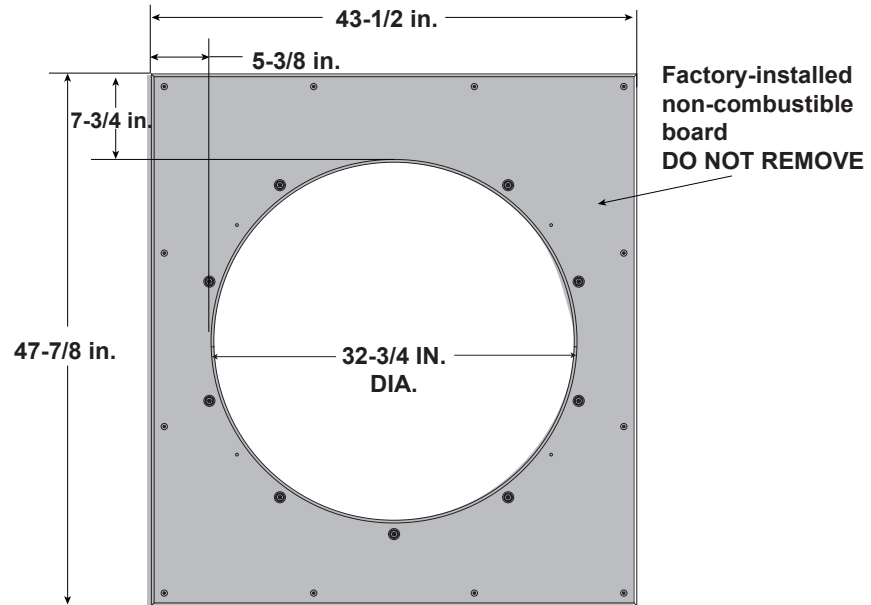

Figure 13.3 Solaris-Back Side,
Finish Wall-for Overlap Door Fit
Wall Sheathing for Inside Door Fit

UNLIMITED DEPTH ALCOVE, MANTEL, OVERHANG, CEILING OR FLOOR;
COMBUSTIBLE OR NON-COMBUSTIBLE;
PERMITTED ENTIRE PERIMETER

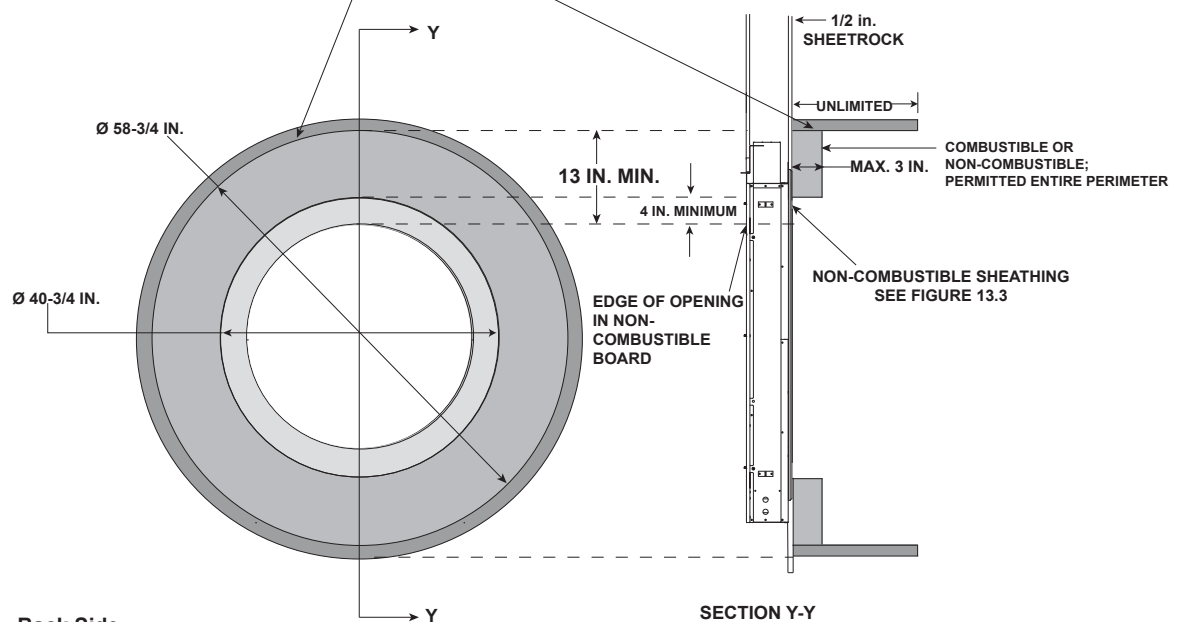
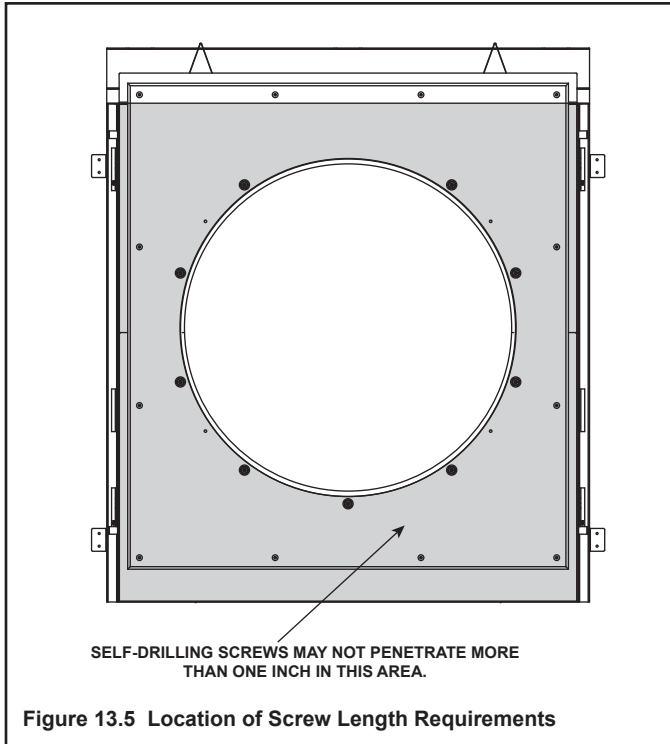

Figure 13.4 Solaris - Back Side
Finish Wall for Overlap Door Fit
Minimum Alcove, Side Wall, Mantel and Overhang Dimensions

Screws

Self-drilling screws are required in the shaded area of Figure 13.5. Fasteners must not penetrate surface of non-combustible board more than one inch.

WARNING! Risk of Fire! DO NOT remove non-combustible board. Observe clearances for combustible facings. Fasteners must not penetrate surface of non-combustible board more than one inch. Damage to the fireplace or glass may result. Use only self-drilling screws.



C. Doors and Finishing - Both Sides

Finish and Sealing Joints

All joints between the finished wall sheathing and the appliance must be sealed with non-combustible materials. Sealants, such as caulk or mastic used to seal the gap between the wall and the fireplace, should be rated at a minimum continuous exposure to 300°F.

Finishing Around Opening with Gypsum Wallboard

Gypsum wallboard (drywall) joints adjacent to the fireplace opening, including the non-combustible board on the appliance, require special attention to minimize cracking. When installing gypsum wallboard around the fireplace, install the hole for the fireplace opening in a single wallboard sheet, if possible. This will minimize the joints adjacent to the fireplace opening.

Tape wall board joints around the fireplace opening with fiberglass-mesh tape. It will provide a more crack-resistant joint than paper tape. Fill, smooth and finish wall joints with chemically setting-type joint compound. It will provide a more crack-resistant joint than air-drying light-weight compound.

Painting

If desired finishing includes a painted wall, 100% acrylic latex with compatible primer is recommended around this appliance. Oil-based or standard acrylic paints may discolor due to heat exposure.

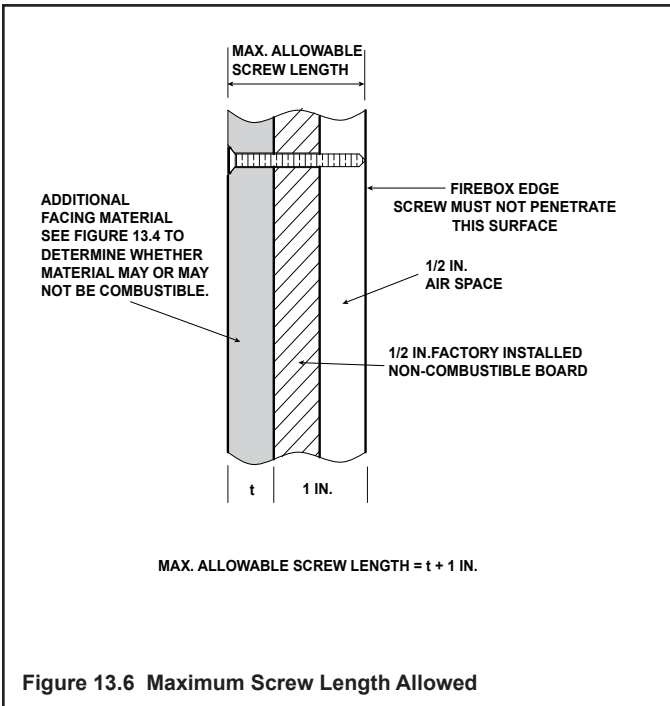

14 Appliance Setup

A. Fixed Glass Assembly

WARNING! Risk of Asphyxiation! Handle fixed glass assembly with care. Inspect the gasket to ensure it is undamaged and inspect the glass for cracks, chips or scratches.

- **DO NOT** strike, slam or scratch glass.
- **DO NOT** operate fireplace with glass removed, cracked, broken or scratched.
- Replace as a complete assembly.

CAUTION! Risk of Injury! It is recommended that two people remove or install the glass assembly due to its weight and size.

Removing Fixed Glass Assembly

- Prepare a work area large enough to accommodate fixed glass assembly and door frame by placing a drop cloth on a flat, stable surface.
- Remove decorative front from appliance and set aside.
- Loosen the ten 3/8 inch nuts that attach the fixed glass assembly to the front of the appliance.
- Remove the ten 3/8 inch nuts carefully while holding the fixed glass assembly in place.
- Set the fixed glass/screened mesh assembly on the prepared work area.

Replacing Fixed Glass Assembly

- Position the fixed glass/screened mesh assembly onto the ten threaded studs on the front of the appliance.
- Manually thread the ten 3/8 inch nuts on the threaded studs.
- Tighten the ten 3/8 inch nuts to secure the fixed glass assembly into position.
- Replace the decorative front onto the appliance.

B. Remove the Shipping Materials

Remove shipping materials from inside or underneath the firebox.

C. Clean the Appliance

Clean/vacuum any sawdust that may have accumulated inside the firebox or underneath in the control cavity.

D. Install Framed Mesh/Decorative Front

Framed Mesh for SOLARIS models is included with the approved decorative fronts. Install framed mesh and decorative fronts per instructions included with decorative fronts. Contact your dealer for a list of approved decorative fronts.

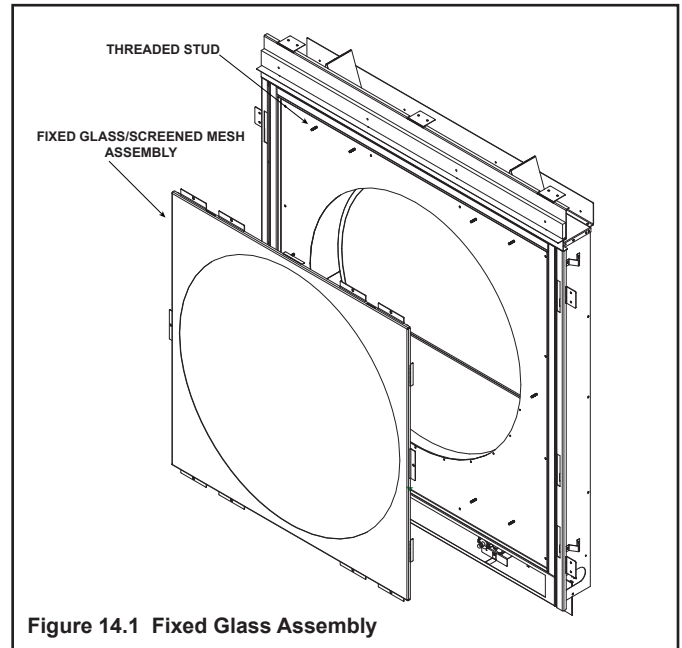

Figure 14.1 Fixed Glass Assembly

WARNING! Risk of Fire and Electric Shock! Use ONLY Hearth & Home Technologies-approved decorative fronts with this appliance. Using non-listed decorative fronts could result in a safety hazard and will void the warranty.

E. Install LED's

LED's are a standard component of the SOLARIS36-MR model. They are packaged separately and must be installed to the back of the SOL-BASE decorative front. For additional LED wiring information, see Figure 12.3 in the electrical section of this manual.

- Remove LED's wire assembly, 3/8 inch nuts and grommets from packaging.
- Install the two grommets into the bottom center of the SOL-BASE decorative front. See Figure 14.2.
- Attach the LED strips to the back of the decorative front by placing the brackets over the threaded studs and then tightening the 3/8 inch nuts, supplied with the LED's, onto the threaded studs. See Figure 14.2.
- Thread one of the ends of the wire assembly that has a small, white plug through one of the grommets and then plug it into the LED strip closest to that grommet. See Figure 14.2.
- Thread the other end of the wire assembly that has a small, white plug through the other grommet and plug it into the remaining LED strip. See Figure 14.2.
- Plug the black LED power supply into the REM/AUX outlet on the junction box.
- Connect the remaining connector on the LED power supply to the LED control harness.
- Connect the large connector on the end of the LED control harness into the wall switch wire harness
- Hang the SOL-BASE on the appliance per the instructions supplied with the SOL-BASE kit.
- Plug the black end of the wire assembly into the open plug on the LED control module.

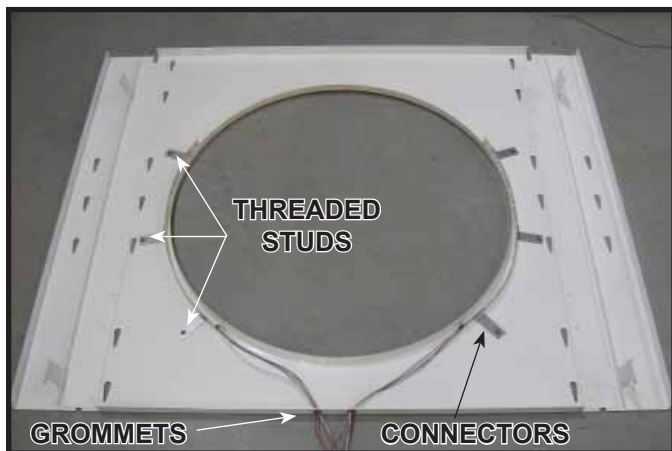

Figure 14.2 LED Installation

F. Air Shutter Setting

Air shutter settings should be adjusted by a qualified service technician at the time of installation. The air shutter is set at the factory for minimum vertical vent run. Adjust air shutter for longer vertical runs. See Figure 14.3.

NOTICE: If sooting occurs, provide more air by opening the air shutter.

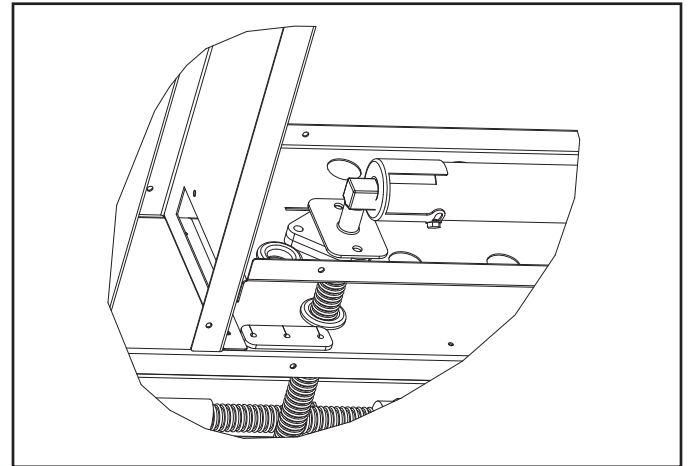

Figure 14.3 Air Shutter

Air Shutter Settings

	NG	LP
SOLARIS36-ST SOLARIS36-MR	3/16 in. (.48cm)	Full Open

G. PVI-SLP-B Operation

Installation Inspection

1. Follow safety inspection procedures recommended by national, provincial, and/or local codes.
2. Be certain all electrical connections are properly made and secure.
3. Visually inspect the vent system and determine that there is no flue gas spillage, blockage or restriction, leakage, corrosion or other unsafe deficiencies.
4. Place the fireplace in operation and determine that the burner and power vent are operating properly. The main burner should show no signs of floating, lifting, or flashbacks.

WARNING: If any unsafe condition is determined when inspecting the installation and operation of the fireplace and Power Vent, the equipment should be shut off. Corrections **MUST** be made before the equipment is put into continuous operation.

Vacuum Switch Orientation

The vacuum switch must be installed on a vertical plane for proper function. If the PVI-SLP-B is mounted in a vertical position, the vacuum switch needs to be moved from its place in Figure 14.4 to the location shown in Figure 14.5. To do this, loosen and remove the two nuts securing it to the inside wall of the PVI-SLP-B. Move and secure the vacuum switch onto the adjacent wall using the two bolts that are sticking out of the surface. Be sure that the tube running from the vacuum switch to the motor is not pinched closed

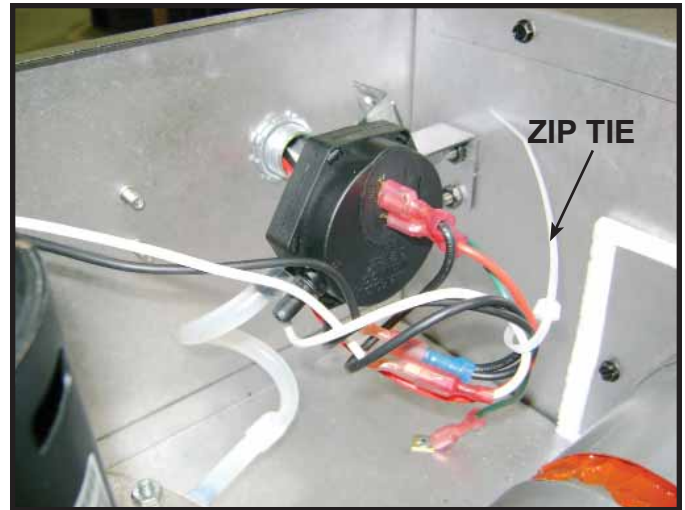

Figure 14.5 Switch Position for Vertical Installation of PVI-SLP-B

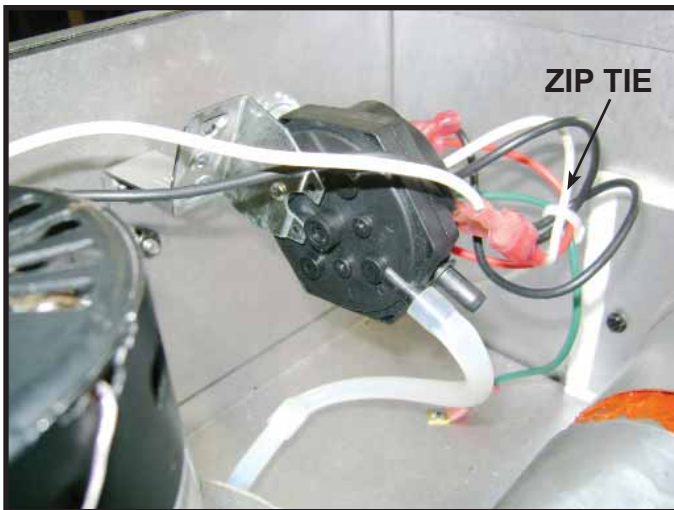

Figure 14.4 Switch Position for Horizontal Installation of PVI-SLP

CAUTION: Risk of electrical shock! DO NOT allow 120VAC wires to contact hot metal surfaces. Use supplied wire ties to bundle wires away from flue pipe, fan housing and other metal surfaces.

Setting the PVI-SLP-B Baffle Adjustment

The PVI-SLP-B has a baffle adjustment which must be set during the Installation Inspection. This baffle adjustment is located alongside the motor. See Figure 14.6

The baffle adjustment is measured using the holes on the indicator bar of the PVI-SLP-B baffle. See Figure 14.7. This bar raises as the baffle is opened and lowers as the baffle is closed. When only one hole is showing, the baffle is closed. When all four holes are visible, the baffle is all the way open. DO NOT TRY TO FORCE IT OPEN ANY FURTHER THAN 1/2 in.

When used with SOLARIS models, the baffle MUST be fully closed.

WARNING: Risk of Fire! Risk of Injury! PVI-SLP-B baffle MUST be fully closed. DO NOT open baffle. Overheating or glass breakage could occur.

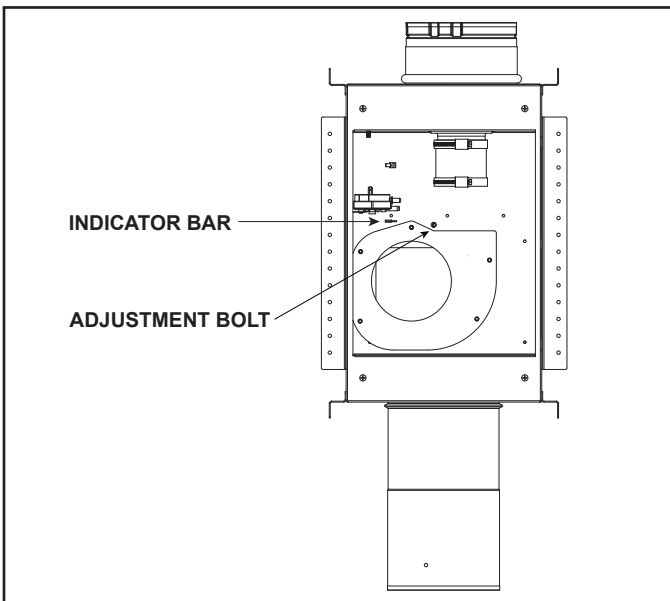

Figure 14.6 Baffle Adjustment Location

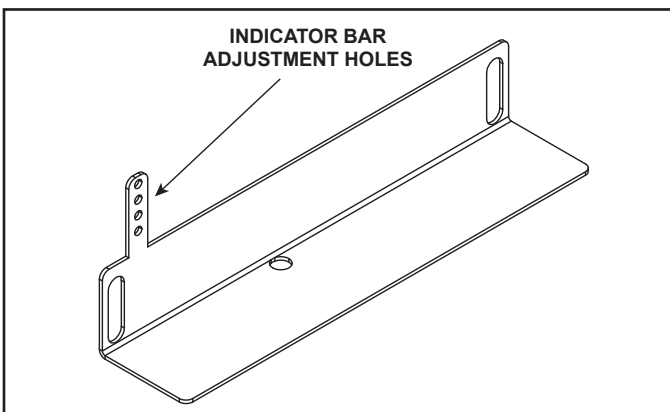

Figure 14.7 Baffle Adjustment

15 Troubleshooting

With proper installation, operation, and maintenance your gas appliance will provide years of trouble-free service. If you do experience a problem, this troubleshooting guide will assist a qualified service technician in the diagnosis of a problem and the corrective action to be taken. This troubleshooting guide can only be used by a qualified service technician. Contact your dealer to arrange a service call by a qualified service technician.

A. IntelliFire™ Plus Ignition System

Symptom	Possible Cause	Corrective Action
1. Pilot won't light. The ignitor/module makes noise, but no spark.	A. Incorrect wiring.	Verify "S" wire (white) for sensor and "I" wire (orange) for ignitor are connected to correct terminals on module and pilot assembly.
	B. Loose connections or electrical shorts in the wiring.	Verify no loose connections or electrical shorts in wiring from module to pilot assembly. Verify connections underneath pilot assembly are tight; also verify igniter and flame sense wires are not grounding out to metal chassis, pilot burner, pilot enclosure, mesh screen if present, or any other metal object.
	C. Ignitor gap is too large.	Verify gap of igniter to right side of pilot hood. The gap should be approximately .17 in. or 1/8 in. (3 mm).
2. Pilot won't light, there is no noise or spark.	A. No power or transformer installed incorrectly.	Verify that transformer is installed and plugged into module. Check voltage of transformer at connection to module. Acceptable readings of a good transformer are between 6.4 and 6.6 volts DC.
	B. A shorted or loose connection in wiring configuration or wiring harness.	Remove and reinstall the wiring harness that plugs into module. Verify there is a tight fit. Verify pilot assembly wiring to module. Remove and verify continuity of each wire in wiring harness. Replace any damaged components.
	C. Improper wall switch wiring.	Verify that 110-120 VAC power is "ON" to junction box.
	D. Module not grounded.	Verify black ground wire from module wire harness is grounded to metal chassis of appliance.
3. Pilot sparks, but Pilot will not light.	A. Gas supply.	Verify that incoming gas line ball valve is "open". Verify that inlet pressure reading is within acceptable limits.
	B. Ignitor gap is too large.	Verify gap of igniter to right side of pilot hood. The gap should be approximately .17 in. or 1/8 in. (3 mm).
	C. Module is not grounded.	Verify module is securely grounded to metal chassis of appliance.
	D. Pilot valve solenoid.	Verify that 1.5 to 1.8 VDC is supplied to pilot solenoid from module. If below 1.5 volts, replace module. If 1.5 volts or greater, replace valve.

Troubleshooting (continued)

Symptom	Possible Cause	Corrective Action
<p>4. Pilot lights but continues to spark, and main burner will not ignite. (If the pilot continues to spark after the pilot flame has been lit, flame rectification has not occurred.)</p>	<p>A. A shorted or loose connection in flame sensing rod.</p>	<p>Verify all connections to wiring diagram in manual. Verify connections underneath pilot assembly are tight. Verify flame sense or igniter wires are not grounding out to metal chassis, pilot burner, pilot enclosure or screen if present, or any other metal object.</p>
	<p>B. Poor flame rectification or contaminated flame sensing rod.</p>	<p>With fixed glass assembly in place, verify that flame is engulfing flame sensing rod on left side of pilot hood. Flame sensing rod should glow shortly after ignition. With a multi-meter, verify that current in series between module and sense lead is at least 0.14 microamps. Verify correct pilot orifice is installed and gas inlet is set to pressure specifications. Polish flame sensing rod with fine steel wool to remove any contaminants that may have accumulated on flame sensing rod.</p>
	<p>C. Module is not grounded.</p>	<p>Verify module is securely grounded to metal chassis of appliance. Verify that wire harness is firmly connected to the module.</p>
	<p>D. Damaged pilot assembly or contaminated flame sensing rod.</p>	<p>Verify that ceramic insulator around the flame sensing rod is not cracked, damaged, or loose. Verify connection from flame sensing rod to white sensor wire. Polish flame sensing rod with fine steel wool to remove any contaminants that may have accumulated on flame sensing rod. Verify continuity with a multi-meter with ohms set at lowest range. Replace pilot if any damage is detected.</p>

B. PVI-SLP-B Troubleshooting

Symptoms	Possible Causes	Corrective Action
IntelliFire™ Plus System		
Main Closes/ Pilot open, 5 seconds later pilot sparking with Blower ON. If condition persists for 60 seconds, 8K-1 locks out with 3 LED alarm.	Pilot Rectification Failure	<ol style="list-style-type: none"> 1. Verify that black wire on IPI wire harness is properly grounded to the fireplace chassis. 2. Verify that pilot is not being compromised by draft such that it fails to rectify. With the glass assembly in place, verify that the pilot flame is engulfing the flame sensing rod on the left side of the pilot hood. With a multi-meter, verify that the current in series between the module and the sense lead is at least 0.14 microamps. 3. Verify that line inlet pressure is within range on rating plate and correct pilot orifice is in pilot. 4. If #1-4 are correct, replace IPI module.
Pilot and Main shut down and 8K1-PVI locks out with 4 LED alarm.	Blocked Flue/Insufficient Draft	<ol style="list-style-type: none"> 1. Verify the teflon pressure tube is connected between blower impeller housing and vacuum switch. 2. Verify that wiring within PVI is correct and that the blower operates during the ignition command. 3. Verify that the venting is connected and sealed properly. 4. Verify that the vent termination is not blocked. 5. If #1 thru #4 are complete, connect black and red wires to bypass vacuum switch. If malfunction is corrected, lock-out system until the vacuum switch can be replaced.
Main Closes, 5 seconds later pilot sparking with Blower ON. If condition persists for 60 seconds, 8K-1 locks out with 3 LED alarm.	Shorted Pilot Sense	<ol style="list-style-type: none"> 1. Verify that the white sensor lead is properly connected to the S-terminal on the module. 2. Check for soot deposits on the pilot sense rod, adjacent shielding, or logs. If so, clean affected parts. 3. Verify that the white sense lead from the pilot is not damaged or melted within the firebox or valve compartment. Replace pilot if damage exists.
Main Closes, 5 seconds later pilot sparking with Blower ON. If condition persists for 60 seconds, 8K-1 locks out with 3 LED alarm.	Disconnected Pilot Sense	Verify that white sensor lead is properly connected to the S-terminal and the orange ignitor lead is connected to the I-terminal on the module
If given ignition command in both ON and REMOTE modes, system immediately locks-out with 3 LED alarm. Does not spark or attempt to ignite.	Pre-Existing/False Pilot Flame	Check for pre-existing pilot flame. If so, the valve is defective and should be replaced.
Pilot rectifies, burner begins to light, but has a difficult time fully lighting.	Draft from back of firebox is too strong due to power vent.	Place ember material along the back side of the ports that are experiencing the difficult lighting. This will block a portion of the strong draft.

16 Reference Materials

A. Appliance Dimension Diagram

Dimensions are actual appliance dimensions. Use for reference only. For framing dimensions and clearances refer to Section 5.

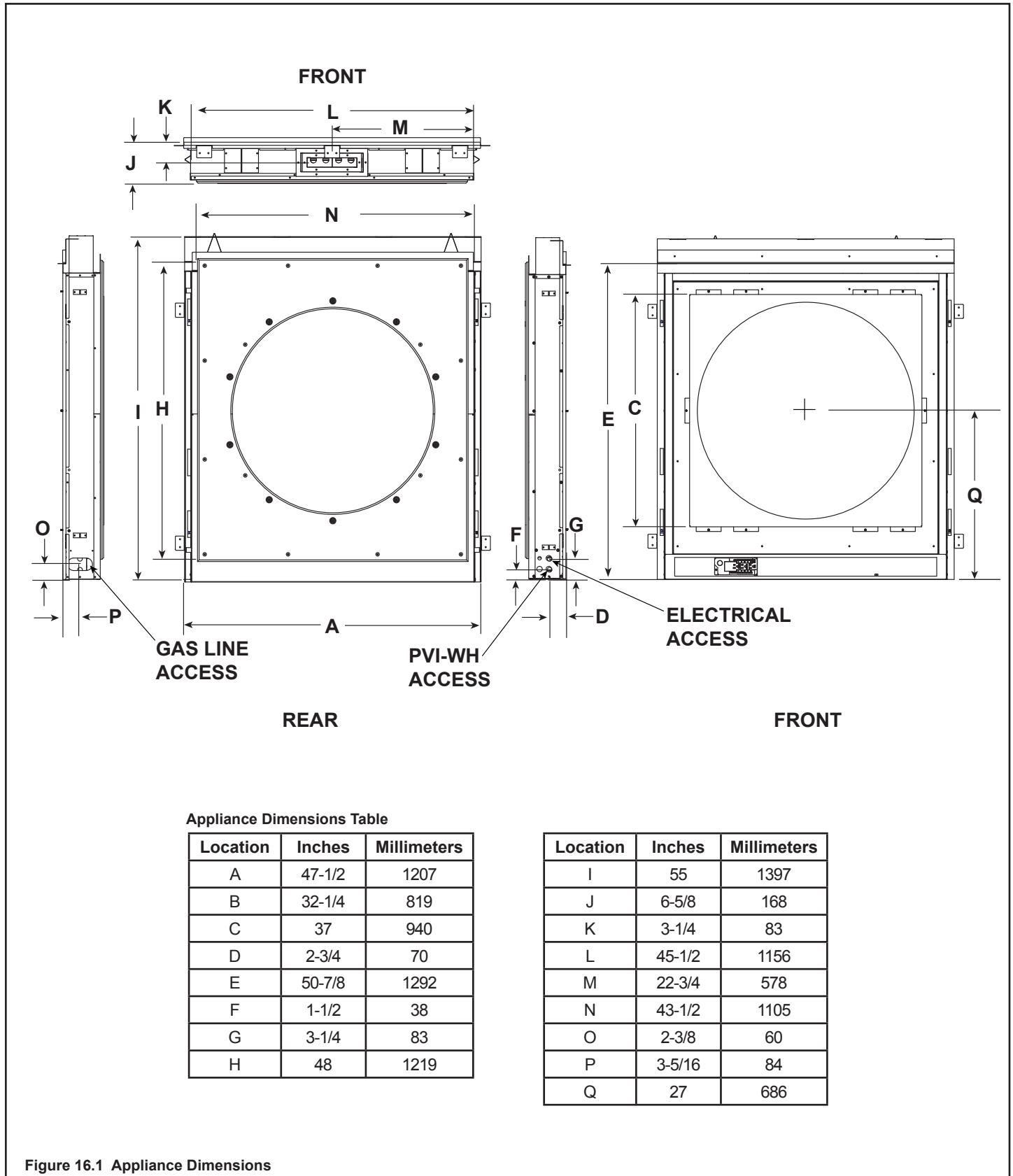
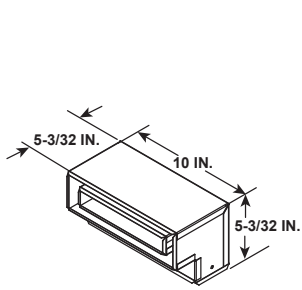
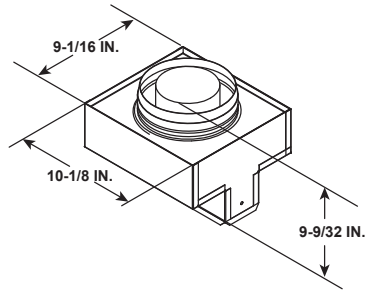

Figure 16.1 Appliance Dimensions

B. Vent Components Diagrams



DVRP90H
90° HORIZONTAL ELBOW



DVRP-2SLP
DVRP TO SLP CONVERTER

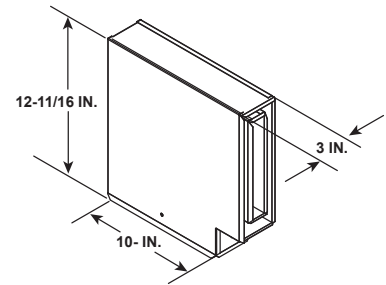

DVRP90V
90° VERTICAL ELBOW

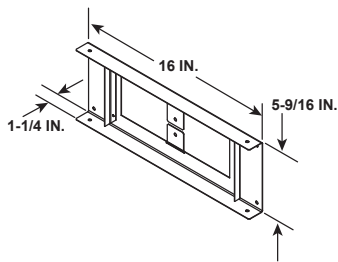

DVRP-CFS
CEILING FIRESTOP

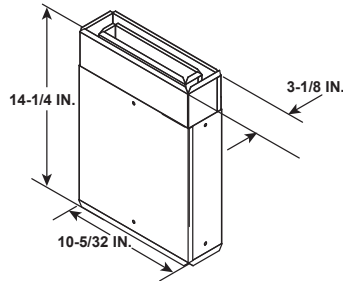

DVRP12A
13 IN. TO 19 IN.
ADJUSTABLE SECTION

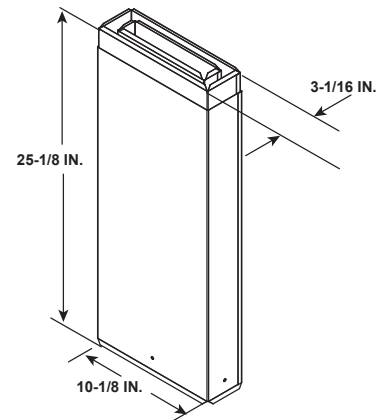

DVRP24
24 IN. FIXED SECTION

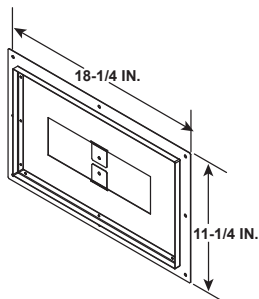

DVRP-WFS
WALL SHIELD FIRESTOP

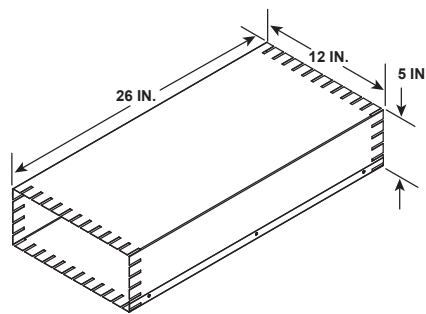

DVRP-AIS
ATTIC INSULATION SHIELD

Figure 16.2 DVRP Vent Components

B. Vent Components Diagrams (continued)

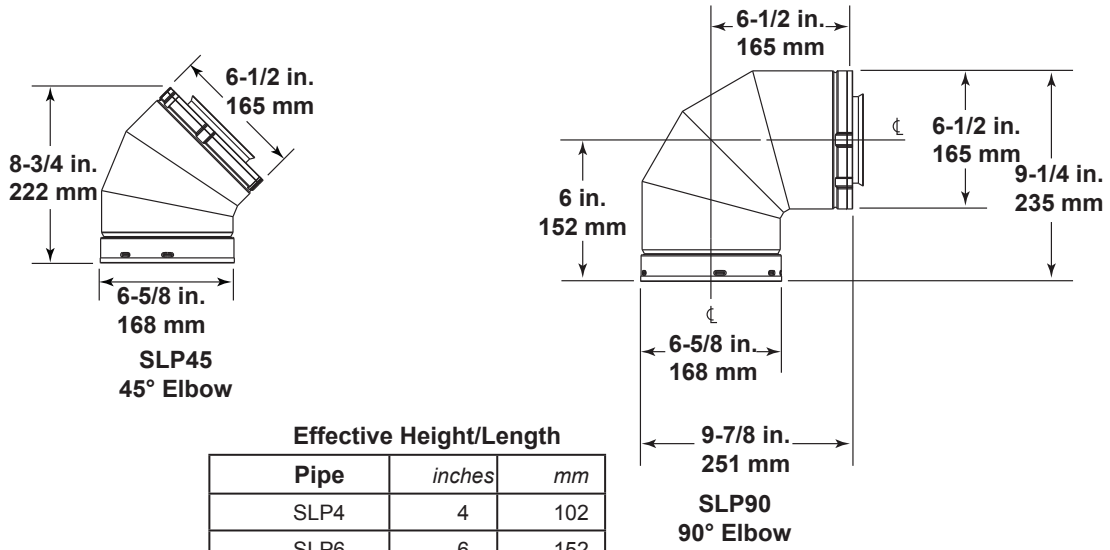

Effective Height/Length

Pipe	inches	mm
SLP4	4	102
SLP6	6	152
SLP12	12	305
SLP24	24	610
SLP36	36	914
SLP48	48	1219
SLP6A	2 - 6	51-152
SLP12A	2 - 12	51-305
SLP-FLEX-2	24	610
SLP-FLEX-3	36	914
SLP-FLEX-5	60	1524
SLP-FLEX-10	120	3048

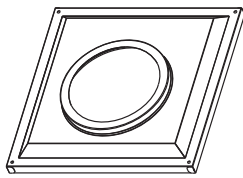
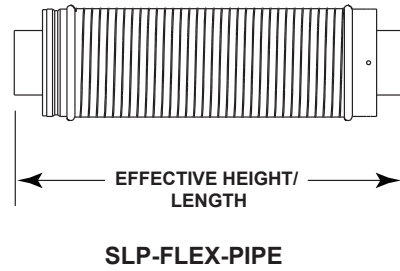
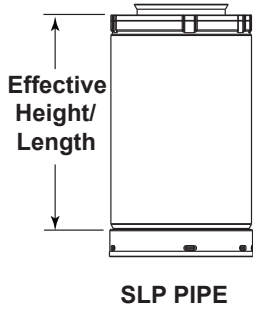

**SLP-WT-BK
Wall Thimble-Black**

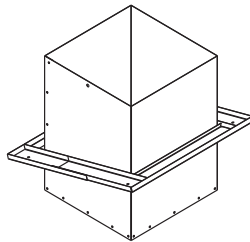

**SLP-CCS-BK
Cathedral Ceiling
Support Box-Black**

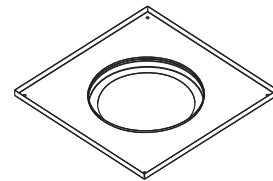

**SLP-DCF-BK
Ceiling Firestop
Black**

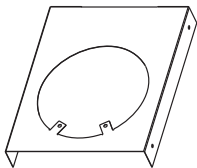

**SLP-HVS
Horizontal Pipe
Support**

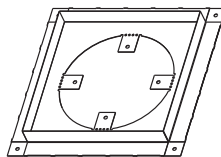

**SLP-FS
Ceiling Firestop**

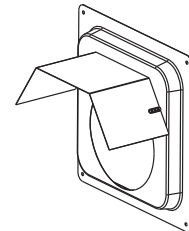

**SLP-WS
Wall Shield Firestop**

Figure 16.3 SLP Series Vent Components

B. Vent Components Diagrams (continued)

Note: Heat shields MUST overlap by a minimum of 1-1/2 in. (38 mm). The heat shield is designed to be used on a wall 4 in. to 7-1/4 in. (102 mm to 184 mm) thick. If wall thickness is less than 4 in. (102 mm) the existing heat shields must be field trimmed. If wall thickness is greater than 7-1/4 in. (184 mm) a DVP-HSM-B will be required.

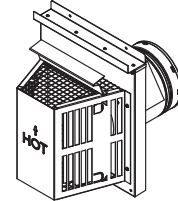
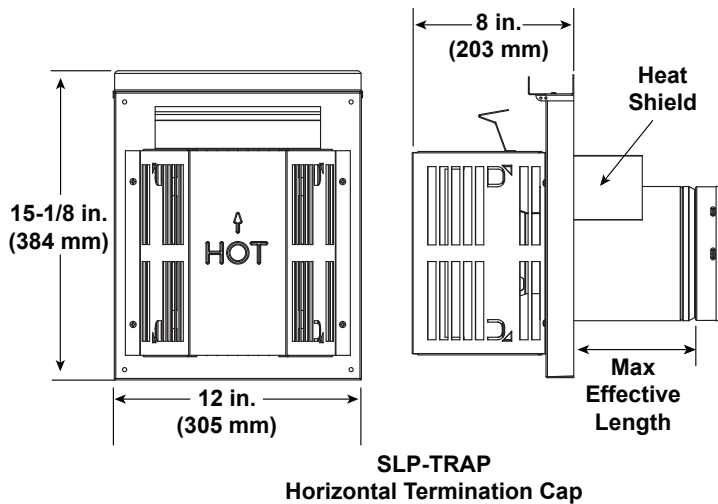

Term Cap	Minimum Effective Length	Maximum Effective Length
Trap1	3-1/8 in.	4-3/4 in.
	79 mm	121 mm
Trap2	5-1/4 in.	9-1/4 in.
	133 mm	235 mm

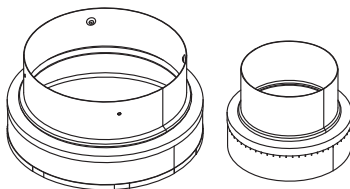

SL-2DVP
Adapter

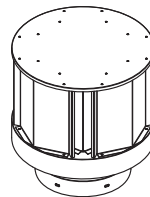

SLP-TVHW
Vertical
Termination Cap

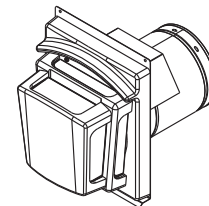

DVP-FBHT
Horizontal
Termination Cap

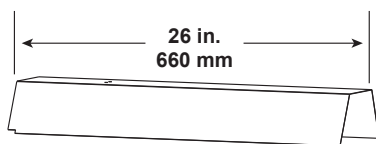

DVP-HSM-B
Extended Heat Shield

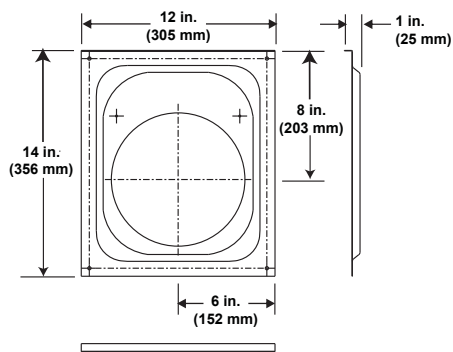

DVP-WS (Wall Shield Firestop)

Figure 16.4 SLP Series Vent Components

B. Vent Components Diagrams (continued)

⚠ WARNING

Fire Risk.

- When using SLP-HRC-SS and SLP-HRC-ZC-SS termination caps on top vented fireplaces, a one foot minimum vertical vent section is required before installing first elbow.
- When using DVP-TB1 termination cap on top vented fireplaces, a three foot minimum vertical vent section is required before installing first elbow.

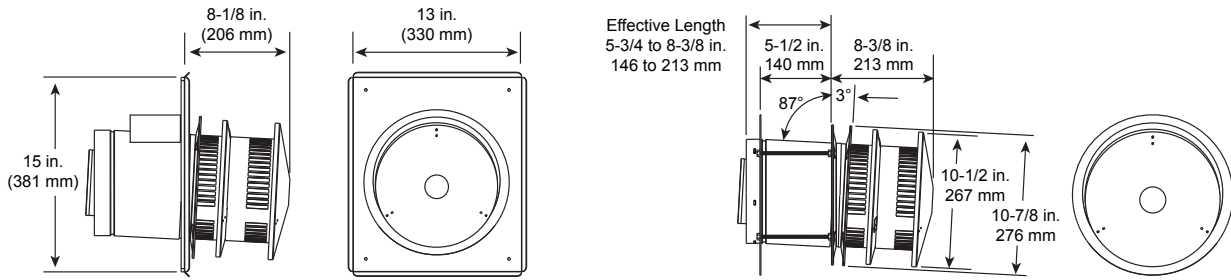

**SLP-HRC-SS
SLP-HRC-ZC-SS
HORIZONTAL TERMINATION CAP**

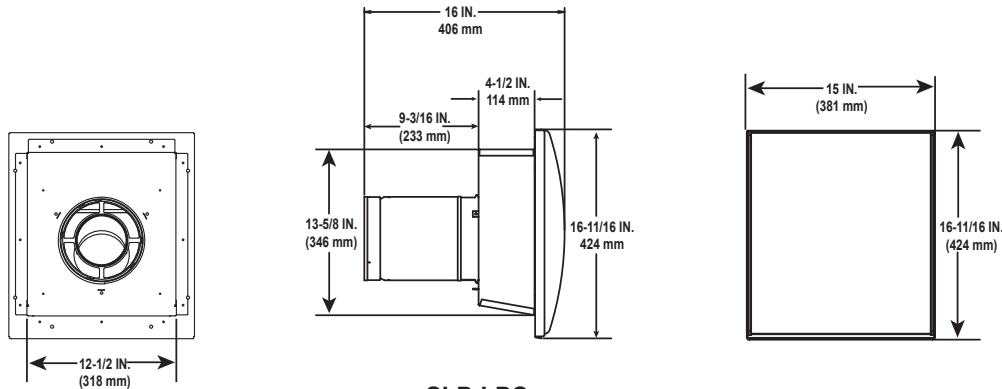

**SLP-LPC
LOW PROFILE CAP**

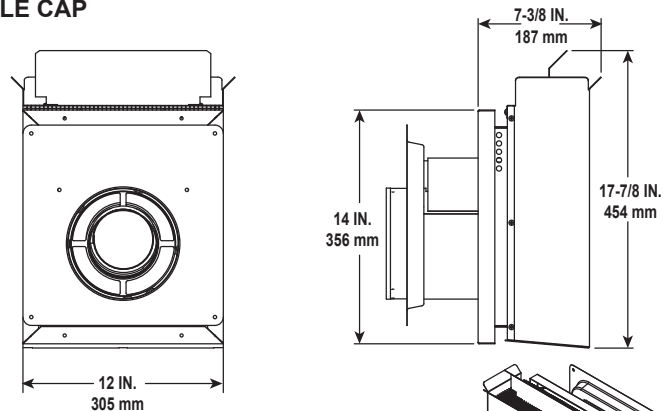

**SLP-TB1
Basement Vent Cap**

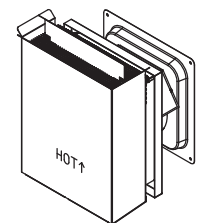

Figure 16.5 SLP Series Vent Components

D. Contact Information



No one builds a better fire

Heat & Glo, a brand of Hearth & Home Technologies
7571 215th Street West, Lakeville, MN 55044
www.heatnglo.com

Please contact your Heat & Glo dealer with any questions or concerns.
For the location of your nearest Heat & Glo dealer,
please visit www.heatnglo.com.

- NOTES -

NOTICE



- Important operating and maintenance instructions included.

DO NOT DISCARD THIS MANUAL

- Read, understand and follow these instructions for safe installation and operation.

- Leave this manual with party responsible for use and operation.



This product may be covered by one or more of the following patents: (United States) 5613487, 5647340, 5890485, 5941237, 6006743, 6019099, 6053165, 6145502, 6374822, 6484712, 6601579, 6769426, 6863064, 7077122, 7098269, 7258116, 7470729, 8147240 or other U.S. and foreign patents pending.

2000-945C

Printed in U.S.A. - Copyright 2016

Heat & Glo • Solaris • 2179-900 Rev. o • 10/16