

Model:
SOHO-B-CEB
SOHO-N-CEB
SOHO-P-CEB

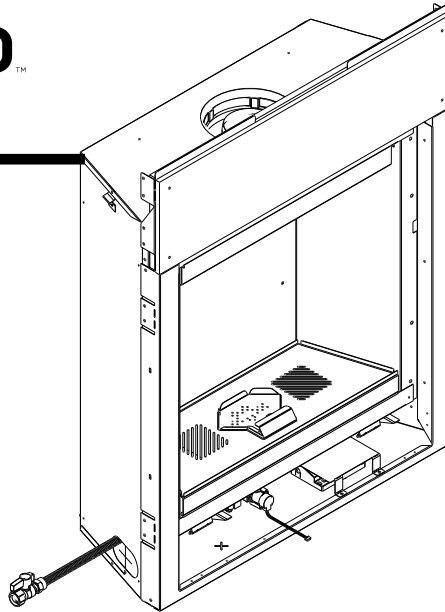

CE
0086

NOTICE



DO NOT DISCARD THIS MANUAL

- Important operating and maintenance instructions included.
- Read, understand and follow these instructions for safe installation and operation.
- Leave this manual with party responsible for use and operation.

**DO NOT
DISCARD**

⚠ WARNING: If the information in these instructions is not followed exactly, a fire or explosion may result causing property damage, personal injury, or death.

- **DO NOT** store or use gasoline or other flammable vapors and liquids in the vicinity of this or any other appliance.
- **DO NOT** spray aerosols in the vicinity of this appliance while it is in operation.
- **What to do if you smell gas**
 - **DO NOT** try to light any appliance.
 - **DO NOT** touch any electrical switch. **DO NOT** use any phone in your building.
 - Immediately call your gas supplier from a neighbor's phone. Follow the gas supplier's instructions.
 - If you cannot reach your gas supplier, call the fire department.
- Installation and service must be performed by a qualified installer, service agency, or the gas supplier.

This is a room sealed appliance and no other ventilation is required than what is provided.

⚠ WARNING



HOT SURFACES!

Glass and other surfaces are hot during operation AND cool down.

Hot glass will cause burns.

- **DO NOT** touch glass until it is cooled
 - **NEVER** allow children to touch glass
 - Keep children away
 - **CAREFULLY SUPERVISE** children in same room as fireplace.
 - Alert children and adults to hazards of high temperatures.
- High temperatures may ignite clothing or other flammable materials.**
- **DO NOT** place articles on or against this appliance.
 - Keep clothing, furniture, draperies and other flammable materials away.

This appliance has been supplied with an integral barrier to prevent direct contact with the fixed glass panel. DO NOT operate the appliance with the barrier removed.

Contact your dealer or Hearth & Home Technologies if the barrier is not present or help is needed to properly install one.

These instructions are only valid if the following country symbol is on the appliance. If this symbol is not present on the appliance, it is necessary to refer to the technical instructions which will provide the necessary information concerning the modification of the appliance to the conditions of use for the country.

These instructions are valid for the following countries: GB

HEAT & GLO™

No one builds a better fire

PLEASE READ THIS MANUAL BEFORE INSTALLING
AND USING THIS APPLIANCE.

**MODEL: SOHO-CEB IS BSI APPROVED FOR
NATURAL GAS, PROPANE OR BUTANE AS A
BALANCED FLUE FIREPLACE.**

Refer to the appliance data plates for gas consumptions and pressures.

Installation of this appliance should only be carried out by an authorized person in accordance with the manufacturer's instructions. Appliance is to be installed in full compliance with the manufacturer's instructions, and any local authorities' requirements for gas, electrical and building regulations.

This appliance and its components are tested and safe when installed in accordance with this Installation Manual. Report to your dealer any parts damaged in shipment, specifically check glass condition. The gas logs and flue system components are in separate packages. Read all instructions before starting installation and follow these instructions carefully during installation to ensure maximum benefit and safety.

Failure to follow them will void your warranty

and may present a fire hazard.

The Heat & Glo, a brand of Hearth & Home Technologies warranty will be voided by, and Heat & Glo, a brand of Hearth & Home Technologies disclaims any responsibility for the following actions:

- Installation of any damaged fireplace or flue system component
- Modification of the fireplace or balanced flue system installation other than as instructed by Heat & Glo, a brand of Hearth & Home Technologies Inc.
- Improper positioning of the gas logs or the glass door
- Installation and/or use of any component part not manufactured or approved by Heat & Glo, brand of Hearth & Home Technologies, notwithstanding any independent testing laboratory or other party approval of such component part or accessory.

It is the responsibility of the professionals involved with the service and installation of the appliance to test the operation of the appliance before leaving the installation site.

IMPORTANT: Read all instructions carefully before starting installation. Failure to follow these installation instructions may result in a possible fire hazard and will void the warranty. Save this manual for future reference.

Heat & Glo, a brand of Hearth & Home Technologies
7571 215th Street West, Lakeville, MN 55044
Copyright 2013 • Printed in U.S.A.

Read this manual before installing or operating this appliance.
Please retain this owner's manual for future reference.

A. Congratulations

Congratulations on selecting a Heat & Glo gas fireplace, an elegant and clean alternative to wood burning fireplaces. The Heat & Glo gas fireplace you have selected is designed to provide the utmost in safety, reliability, and efficiency.

As the owner of a new fireplace, you'll want to read and carefully follow all of the instructions contained in this owner's manual. Pay special attention to all cautions and warnings.

This owner's manual should be retained for future reference. We suggest that you keep it with your other important documents and product manuals.

The information contained in this owner's manual, unless noted otherwise, applies to all models and gas control systems.

Your new Heat & Glo gas fireplace will give you years of durable use and trouble-free enjoyment. Welcome to the Heat & Glo family of fireplace products!

Homeowner Reference Information		<i>We recommend that you record the following pertinent information about your fireplace.</i>	
Model Name: _____	Date purchased/installed: _____		
Serial Number: _____	Location on fireplace: _____		
Dealership purchased from: _____	Dealer Phone: _____		
Notes: _____			

Listing Label Information/Location

The model information regarding your specific fireplace can be found on the rating plate usually located in the control area of the fireplace.

Type of Gas

No one builds a better fire
PIN: 87BU58

Heat & Glo, a brand of Hearth & Home Technologies Inc.
 7571 215th Street West, Lakeville, MN 55044 USA

BSI

MADE IN USA

Gas Type	G20	G20	G20/25
Destination	AT,ES,DE,GB,GR,LU,NO,SK	DE	FR
CAT	I _{2H}	I _{2E}	I _{2E+}
Heat Input (Net)	7.32 kW	7.32 kW	7.32 kW
Pn	20 mbar	20 mbar	20/25 mbar
Burner Pressure	8.7 mbar	9.5 mbar	9.5/11.5 mbar
Injector	#42 DMS	#42 DMS	#42 DMS
Efficiency Class	2	2	2
Gas Rate m ³ /h	.70	.70	.70/.68
Electrical Requirements: 230 V / 50 hz / 1A			

This appliance must be installed in accordance with the rules in force, and used only in a sufficiently vented space. Consult instructions before installation and use of this appliance.

DO NOT REMOVE OR COVER THIS LABEL.

Model: **XXXXXXXX**
 Serial: **XXXXXXXX**

Model Number

Serial Number

xxxx-xxx

▲ Safety Alert Key:

- **DANGER!** Indicates a hazardous situation which, if not avoided will result in death or serious injury.
- **WARNING!** Indicates a hazardous situation which, if not avoided could result in death or serious injury.
- **CAUTION!** Indicates a hazardous situation which, if not avoided, could result in minor or moderate injury.
- **NOTICE:** Used to address practices not related to personal injury.

Table of Contents

A. Congratulations	3
B. Limited Lifetime Warranty.	6

1 Listing and Code Approvals

A. Appliance Certification	8
B. Additional Related Standards.	8
C. Gas Pressure Requirements	8
D. High Altitude Installations.	8
E. Non-Combustible Materials Specification.	8
F. Combustible Materials Specification	8
G. Electrical Codes	8

User Guide

2 Operating Instructions

A. Gas Fireplace Safety	9
B. Your Fireplace	9
C. Clear Space	10
D. Decorative Doors and Fronts	10
E. Fixed Glass Assembly	10
F. Remote Controls, Wall Controls and Wall Switches.	10
G. Before Lighting Fireplace	10
H. Control Module Operation	11
I. Lighting Instructions (IPI)	12
J. After Fireplace is Lit	13
K. Frequently Asked Questions	13

3 Maintenance and Service

A. Maintenance Tasks-Homeowner	14
B. Maintenance Tasks-Qualified Service Technician	15

Installer Guide

4 Getting Started

A. Typical Appliance System.	17
B. Design and Installation Considerations	18
C. Tools and Supplies Needed	18
D. Inspect Appliance and Components.	18

5 Framing and Clearances

A. Selecting Appliance Location	19
B. Constructing the Appliance Chase	20
C. Clearances	20
D. Mantel and Wall Projections.	21

6 Termination Locations

A. Vent Termination Minimum Clearances	22
--	----

7 Vent Information and Diagrams

A. Approved Pipe	24
B. Vent Table Key	24
C. Use of Elbows	24
D. Measuring Standards	24
E. Flue Diagrams	24

8 Vent Clearances and Framing

A. Pipe Clearances to Combustibles	31
B. Wall Penetration Framing.	31
C. Install the Ceiling Firestop	32
D. Install Attic Insulation Shield.	33

9 Appliance Preparation

A. Top Vent	34
B. Installation of Non-combustible Facing Material	35
C. Securing and Leveling the Appliance	36
D. Covers Removal For Servicing.	37
E. Components Removal For Service	37
F. Parts Replacement.	37
G. Adjustments And Replacement Parts.	37
H. Install Trim and/or Surround	37
I. Air Shutter Setting	37

10 Installing Vent Pipe (SLP Pipe)

A. Assemble Vent Sections.	38
B. Assemble Slip Sections	39
C. Secure the Vent Sections.	39
D. Disassemble Vent Sections	40
E. Install Support Brackets	41
F. Install Firestops	41
G. Flue Termination	42
H. Heat Shield Requirements for Horizontal Termination	43
I. Install Metal Roof Flashing.	43
J. Assemble and Install Storm Collar.	44
K. Install Vertical Termination Cap	44

11 Gas Information

→ A. Gas Pressure Requirements	45
B. Gas Connection	45

12 Electrical Information

A. Wiring Requirements	47
B. IntelliFire Plus™ Ignition System Wiring	47
C. Optional Accessories Requirements	47
D. Control Module Operation	48

13 Finishing

A. Mantel and Wall Projections	55
B. Facing Material	55
C. Framing and Finishing Instructions	56

14 Appliance Setup

A. Remove Fixed Glass Assembly	57
B. Remove the Shipping Materials	57
C. Clean the Appliance	57
D. Accessories	57
E. Log Placement Instructions	58
F. Install Media Rock Kit	59
G. IPI Module Reset Switch	60

15 Troubleshooting

A. IntelliFire Plus™ Ignition System	61
--	----

16 Reference Materials

A. Appliance Dimension Diagram	63
B. Maintenance Tasks	64
C. Vent Components Diagrams	65
→ D. Service Parts	68
→ E. Contact Information	71

→ = Contains updated information.

B. Limited Lifetime Warranty

Hearth & Home Technologies Inc. LIMITED LIFETIME WARRANTY

Hearth & Home Technologies Inc., on behalf of its hearth brands ("HHT"), extends the following warranty for HHT gas, wood, pellet, coal and electric hearth appliances that are purchased from an HHT authorized dealer.

WARRANTY COVERAGE:

HHT warrants to the original owner of the HHT appliance at the site of installation, and to any transferee taking ownership of the appliance at the site of installation within two years following the date of original purchase, that the HHT appliance will be free from defects in materials and workmanship at the time of manufacture. After installation, if covered components manufactured by HHT are found to be defective in materials or workmanship during the applicable warranty period, HHT will, at its option, repair or replace the covered components. HHT, at its own discretion, may fully discharge all of its obligations under such warranties by replacing the product itself or refunding the verified purchase price of the product itself. The maximum amount recoverable under this warranty is limited to the purchase price of the product. This warranty is subject to conditions, exclusions and limitations as described below.

WARRANTY PERIOD:

Warranty coverage begins on the date of original purchase. In the case of new home construction, warranty coverage begins on the date of first occupancy of the dwelling or six months after the sale of the product by an independent, authorized HHT dealer/ distributor, whichever occurs earlier. The warranty shall commence no later than 24 months following the date of product shipment from HHT, regardless of the installation or occupancy date. The warranty period for parts and labor for covered components is produced in the following table.

The term "Limited Lifetime" in the table below is defined as: 20 years from the beginning date of warranty coverage for gas appliances, and 10 years from the beginning date of warranty coverage for wood, pellet, and coal appliances. These time periods reflect the minimum expected useful lives of the designated components under normal operating conditions.

Warranty Period		HHT Manufactured Appliances and Venting							Components Covered
Parts	Labor	Gas	Wood	Pellet	EPA Wood	Coal	Electric	Venting	
1 Year		X	X	X	X	X	X	X	All parts and material except as covered by Conditions, Exclusions, and Limitations listed
2 years				X	X	X			Igniters, electronic components, and glass
		X	X	X	X	X			Factory-installed blowers
				X					Molded refractory panels
3 years				X					Firepots and burnpots
5 years	1 year			X	X				Castings and baffles
7 years	3 years		X	X	X				Manifold tubes, HHT chimney and termination
10 years	1 year	X							Burners, logs and refractory
Limited Lifetime	3 years	X	X	X	X	X			Firebox and heat exchanger
90 Days		X	X	X	X	X	X	X	All replacement parts beyond warranty period

See conditions, exclusions, and limitations on next page.

WARRANTY CONDITIONS:

- This warranty only covers HHT appliances that are purchased through an HHT authorized dealer or distributor. A list of HHT authorized dealers is available on the HHT branded websites.
- This warranty is only valid while the HHT appliance remains at the site of original installation.
- Contact your installing dealer for warranty service. If the installing dealer is unable to provide necessary parts, contact the nearest HHT authorized dealer or supplier. Additional service fees may apply if you are seeking warranty service from a dealer other than the dealer from whom you originally purchased the product.
- Check with your dealer in advance for any costs to you when arranging a warranty call. Travel and shipping charges for parts are not covered by this warranty.

WARRANTY EXCLUSIONS:

This warranty does not cover the following:

- Changes in surface finishes as a result of normal use. As a heating appliance, some changes in color of interior and exterior surface finishes may occur. This is not a flaw and is not covered under warranty.
- Damage to printed, plated, or enameled surfaces caused by fingerprints, accidents, misuse, scratches, melted items, or other external sources and residues left on the plated surfaces from the use of abrasive cleaners or polishes.
- Repair or replacement of parts that are subject to normal wear and tear during the warranty period. These parts include: paint, wood, pellet and coal gaskets, firebricks, grates, flame guides, light bulbs, batteries and the discoloration of glass.
- Minor expansion, contraction, or movement of certain parts causing noise. These conditions are normal and complaints related to this noise are not covered by this warranty.
- Damages resulting from: (1) failure to install, operate, or maintain the appliance in accordance with the installation instructions, operating instructions, and listing agent identification label furnished with the appliance; (2) failure to install the appliance in accordance with local building codes; (3) shipping or improper handling; (4) improper operation, abuse, misuse, continued operation with damaged, corroded or failed components, accident, or improperly/incorrectly performed repairs; (5) environmental conditions, inadequate ventilation, negative pressure, or drafting caused by tightly sealed constructions, insufficient make-up air supply, or handling devices such as exhaust fans or forced air furnaces or other such causes; (6) use of fuels other than those specified in the operating instructions; (7) installation or use of components not supplied with the appliance or any other components not expressly authorized and approved by HHT; (8) modification of the appliance not expressly authorized and approved by HHT in writing; and/or (9) interruptions or fluctuations of electrical power supply to the appliance.
- Non-HHT venting components, hearth components or other accessories used in conjunction with the appliance.
- Any part of a pre-existing fireplace system in which an insert or a decorative gas appliance is installed.
- HHT's obligation under this warranty does not extend to the appliance's capability to heat the desired space. Information is provided to assist the consumer and the dealer in selecting the proper appliance for the application. Consideration must be given to appliance location and configuration, environmental conditions, insulation and air tightness of the structure.

This warranty is void if:

- The appliance has been over-fired or operated in atmospheres contaminated by chlorine, fluorine, or other damaging chemicals. Over-firing can be identified by, but not limited to, warped plates or tubes, rust colored cast iron, bubbling, cracking and discoloration of steel or enamel finishes.
- The appliance is subjected to prolonged periods of dampness or condensation.
- There is any damage to the appliance or other components due to water or weather damage which is the result of, but not limited to, improper chimney or venting installation.

LIMITATIONS OF LIABILITY:

- The owner's exclusive remedy and HHT's sole obligation under this warranty, under any other warranty, express or implied, or in contract, tort or otherwise, shall be limited to replacement, repair, or refund, as specified above. In no event will HHT be liable for any incidental or consequential damages caused by defects in the appliance. Some states do not allow exclusions or limitation of incidental or consequential damages, so these limitations may not apply to you. This warranty gives you specific rights; you may also have other rights, which vary from state to state. EXCEPT TO THE EXTENT PROVIDED BY LAW, HHT MAKES NO EXPRESS WARRANTIES OTHER THAN THE WARRANTY SPECIFIED HEREIN. THE DURATION OF ANY IMPLIED WARRANTY IS LIMITED TO DURATION OF THE EXPRESSED WARRANTY SPECIFIED ABOVE.

1 Listing and Code Approvals

A. Appliance Certification

MODELS: SOHO-B-CEB, SOHO-N-CEB, SOHO-P-CEB

LABORATORY: BSI

TYPE: Gas Fireplace

STANDARD: Latest version of BS EN:613:2001

DIRECTIVE: GAD90/396/EEC

B. Additional Related Standards

The installation must comply with these installation instructions and all relevant parts of Local and National Building Standards Regulations and those relevant recommendations of the following British Standards. BS 5871: Part 1 BS 8303 BS 5440: Parts 1 & 2 BS 6891 BSEN1856 Parts 1 & 2 BS 5482 Part 1, as well as IGE/UP/7.

NOT INTENDED FOR USE AS A PRIMARY HEAT SOURCE.

This appliance is tested and approved as either supplemental room heat or as a decorative appliance. It should not be factored as primary heat in residential heating calculations.

The Heat & Glo gas appliances discussed in this Installer's Guide have been tested to certification standards and listed by the applicable laboratories.

This appliance must be installed in accordance with the rules in force.
NOX Class 5 for G20, NOX Class 5 for G31

C. Gas Pressure Requirements

Pressure requirements for SOHO-CEB fireplace are shown in table below.

Two taps are provided on the right hand side of the gas control for a test gauge connection to measure the inlet and outlet pressures.

	Natural Gas (G20)	Natural Gas (G25)	Butane (G30)	Propane (G31)
CAT	I _{2H} , I _{2E} , I _{2E+}	I _{2E+}	I _{3B/P}	I _{3P}
Inlet Pressure	20 mbar	25 mbar	37 or 50 mbar	37 or 50 mbar
Burner Pressure	8,4 mbar	8,4 mbar	24 mbar	24 mbar
Gas Rate	Max. 0,405 m ³ /h	Max. 0,405 m ³ /h	Max. 0,111 m ³ /h	Max. 0,134 m ³ /h
Heat Input (Net)	4,0 kW	3,5 kW	3,6 kW	3,5 kW
Burner Injector	DMS 50 (1,78 mm)	DMS 50 (1,78 mm)	DMS 61 (1,07 mm)	DMS 58 (1 mm)
Pilot Injector	0,023	0,023	0,010	0,014

Columns highlighted in gray = The gas control valve supplied with this product is approved for a maximum inlet pressure of 37 mbar. For pressures over 37 mbar, an in line pressure regulator must be installed upstream from the gas control valve.

The fireplace and its individual shut-off valve must be disconnected from the gas supply piping system during any pressure testing of the system at test pressures in excess of 60 mbar.

If the fireplace must be isolated from the gas supply piping system by closing an individual shut-off valve, it must be of the handle-less type.

WARNING! Risk of Explosion! An in-line regulator **MUST** be installed if the gas pressure exceeds 37 mbar. Failure to install a regulator could damage valve.

D. High Altitude Installations

NOTICE: If the heating value of the gas has been reduced, these rules do not apply. Check with your local gas utility or authorities having jurisdiction.

When installing above 610 meter elevation:

Reduce input rate 4% for each 305 meters feet above 610 meters.

E. Non-Combustible Materials Specification

Material which will not ignite and burn. Such materials are those consisting entirely of steel, iron, brick, tile, concrete, slate, glass or plasters, or any combination thereof.

Materials that are reported as passing **ASTM E 136, Standard Test Method for Behavior of Materials in a Vertical Tube Furnace at 750 °C** and **UL763** shall be considered non-combustible materials.

F. Combustible Materials Specification

Materials made of or surfaced with wood, compressed paper, plant fibers, plastics, or other material that can ignite and burn, whether flame proofed or not, or plastered or unplastered shall be considered combustible materials.

G. Electrical Codes

All electrical safety testing has been done following the EN 60335-2-102 standard. Local codes apply.

A. Gas Fireplace Safety

⚠ WARNING



HOT SURFACES!

Glass and other surfaces are hot during operation AND cool down.

Hot glass will cause burns.

- **DO NOT** touch glass until it is cooled
- **NEVER** allow children to touch glass
- Keep children away

- **CAREFULLY SUPERVISE** children in same room as fireplace.
- Alert children and adults to hazards of high temperatures.

High temperatures may ignite clothing or other flammable materials.

- Keep clothing, furniture, draperies and other flammable materials away.

This appliance has been supplied with an integral barrier to prevent direct contact with the fixed glass panel. DO NOT operate the appliance with the barrier removed.

Contact your dealer or Hearth & Home Technologies if the barrier is not present or help is needed to properly install one.

This appliance is not intended for use by persons (including children) with reduced physical, sensory or mental capabilities, or lack of experience and knowledge, unless they have been given supervision or instruction concerning use of the appliance by a person responsible for their safety.

Children should be supervised to ensure that they do not play with the appliance.

If you expect that small children or vulnerable adults may come into contact with this fireplace, the following precautions are recommended:

- Install a physical barrier such as:
 - A decorative firescreen.
 - Adjustable safety gate.
- Install a switch lock or a wall/remote control with child protection lockout feature.
- Keep remote controls out of reach of children.
- Never leave children alone near a hot fireplace, whether operating or cooling down.
- Teach children to **NEVER** touch the fireplace.
- Consider not using the fireplace when children will be present.

To prevent unintended operation when not using your fireplace for an extended period of time (summer months, vacations, trips, etc):

- Remove batteries from remote controls.
- Turn off wall controls.
- Unplug 6 volt adapter plug and remove batteries on IPI models.

B. Your Fireplace

WARNING! DO NOT operate fireplace before reading and understanding operating instructions. Failure to operate fireplace according to operating instructions could cause fire or injury.

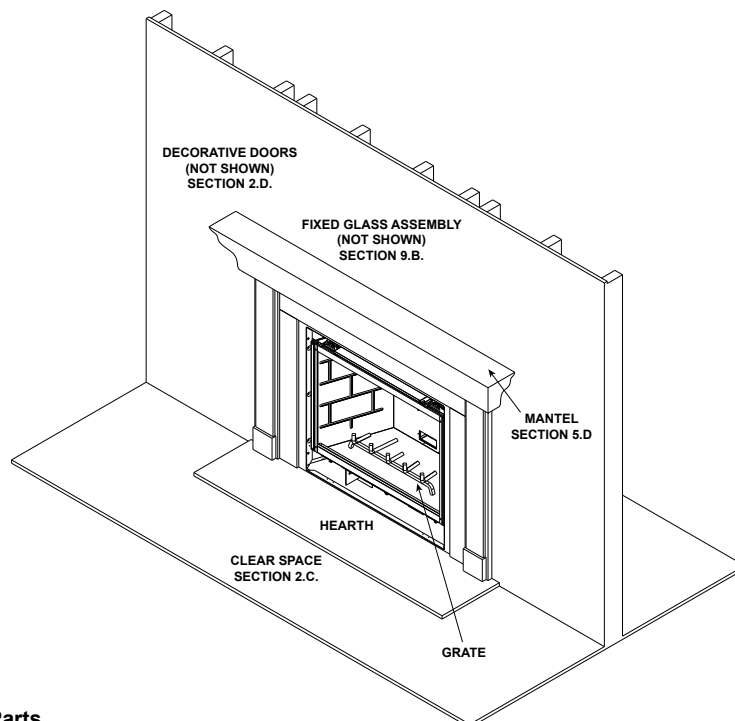

Figure 2.1 General Operating Parts

C. Clear Space

WARNING! DO NOT place combustible objects in front of the fireplace or block louvers. High temperatures may start a fire. See Figure 2.2.

Avoid placing candles and other heat-sensitive objects on mantel or hearth. Heat may damage these objects.

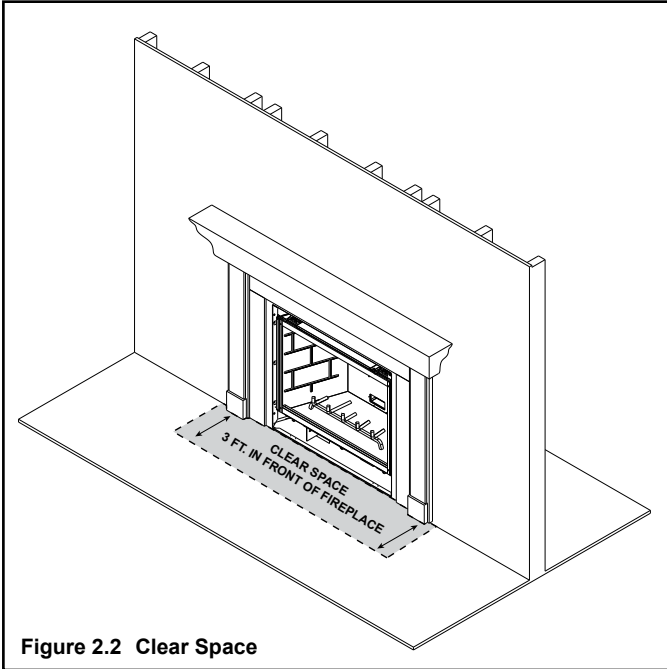

Figure 2.2 Clear Space

D. Decorative Doors and Fronts

WARNING! Risk of Fire! Install **ONLY** doors or fronts approved by **Hearth & Home Technologies**. Unapproved doors or fronts may cause fireplace to overheat.

This fireplace has been supplied with an integral barrier to prevent direct contact with the fixed glass panel. DO NOT operate the fireplace with the barrier removed.

Contact your dealer or **Hearth & Home Technologies** if the barrier is not present or help is needed to properly install one.

For more information refer to the instructions supplied with your decorative door or front.

E. Fixed Glass Assembly

See Section 9.B.

F. Remote Controls, Wall Controls and Wall Switches

Follow the instructions supplied with the control installed to operate your fireplace:

For safety:

- Install a switch lock or a wall/remote control with child protection lockout feature.
- Keep remote controls out of reach of children.

See your dealer if you have questions.

G. Before Lighting Fireplace

Before operating this fireplace for the first time, **have a qualified service technician:**

- Verify all shipping materials have been removed from inside and/or underneath the firebox.
- Review proper placement of logs, ember material and/or other decorative materials.
- Check the wiring.
- Check the air shutter adjustment.
- Ensure that there are no gas leaks.
- Ensure that the glass is sealed and in the proper position and that the integral barrier is in place.

WARNING! Risk of Fire or Asphyxiation! DO NOT operate fireplace with fixed glass assembly removed.

Nine Hour Safety Shutdown Feature

The appliance has a safety feature that automatically shuts down the fireplace after nine hours of continuous operation without receiving a command from the wall switch or optional remote.

H. Control Module Operation

1. The control module has an ON/OFF/REMOTE selector switch that must be set. See Figure 2.3.

OFF Position: Appliance will ignore all power inputs and will not respond to any commands from a wall switch or remote. The unit should be in the OFF position during installation, service, battery installation, fuel conversion, and in the event that the control goes into LOCK-OUT mode as a result of an error code.

ON Position: Appliance will ignite and run continuously in the HI flame setting, with no adjustment in flame output. This mode of operation is primarily used for initial installation or power outage operation with battery backup.

REMOTE Position: Appliance will initiate commands from an optional wired wall switch and/or the wireless remote (RC300CE).

2. If using a wired wall switch with the module in REMOTE mode, the flame output can be adjusted with the HI/LO selector switch on the module. See Figure 2.3. Note that the flame HI/LO selector switch will become inactive once an optional remote control (RC300CE) is programmed to the control module. Note that the control module will always ignite the fireplace on HI and remain so for the initial 10 seconds of operation. If the HI/LO is switched to the LO position, the flame output will automatically drop to the lowest setting after the flame has been established for 10 sec. After this 10 second period, the flame can be adjusted from HI to LO with the switch.
3. The control module has safety feature that automatically shuts down the fireplace after 9 hours of continuous operation without receiving a command from the RC300CE remote.
4. If you intend to use both an optional wired wall switch and the RC300CE remote control to operate your fireplace, the wall switch will override any commands given by the remote.

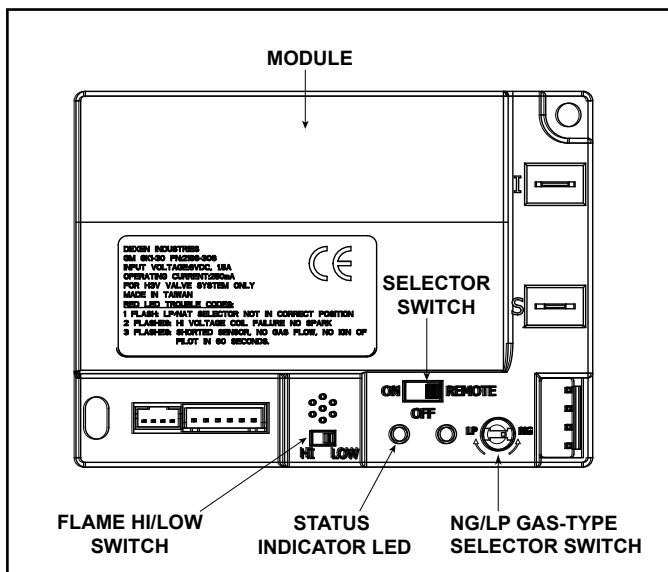

Figure 2.3 Control Module

5. Module Reset Switch

This module may lock-out under certain conditions. When this occurs, the appliance will not ignite or respond to commands. The module will go into lock-out mode by emitting three audible beeps, then continuously displaying an error code at its status indicator LED.

- Check battery tray. Remove batteries if installed. Batteries should only be installed for use during power outages. See Section H.
- Locate the module reset switch. See Figures 2.4 or 2.5.
- Set the module reset switch to the RESET position.
- Wait five (5) minutes to allow possible accumulated gas to clear.
- Set the module reset switch to ON.
- Start the appliance.

WARNING! Risk of Explosion! DO NOT press the module reset switch more than one time within a five minute time period. Gas may accumulate in firebox. Call a qualified service technician.

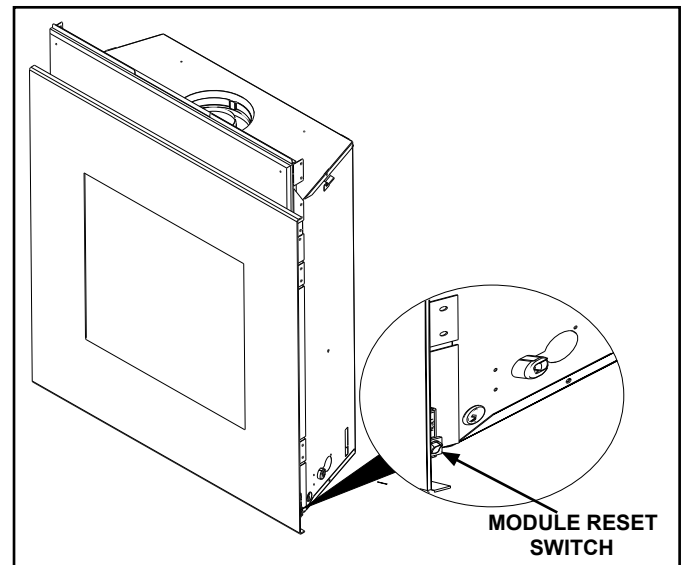

Figure 2.4 Location of Module Reset Switch - Studio Front

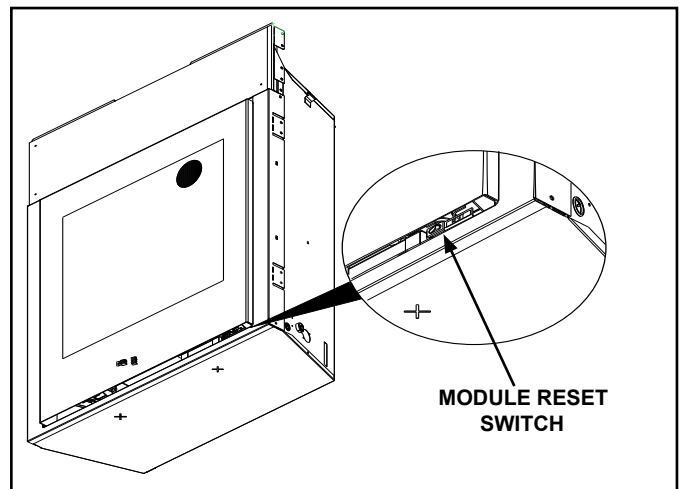

Figure 2.5 Location of Module Reset Switch - DF-Soho-CE Front

I. Lighting Instructions (IPI)

FOR YOUR SAFETY READ BEFORE LIGHTING

WARNING: If you do not follow these instructions exactly, a fire or explosion may result causing property damage, personal injury or loss of life.

- A.** This appliance is equipped with an intermittent pilot ignition (IPI) device which automatically lights the burner. **DO NOT** try to light the burner by hand.
- B. BEFORE LIGHTING,** smell all around the appliance area for gas. Be sure to smell next to the floor because some gas is heavier than air and will settle on the floor.

WHAT TO DO IF YOU SMELL GAS

- **DO NOT** try to light any appliance.
- **DO NOT** touch any electric switch; do not use any phone in your building.

WARNING:

DO NOT CONNECT LINE VOLTAGE (110/120 VAC OR 220/240 VAC) TO THE CONTROL VALVE.

Improper installation, adjustment, alteration, service or maintenance can cause injury or property damage. Refer to the owner's information manual provided with this appliance.

This appliance needs fresh air for safe operation and must be installed so there are provisions for adequate combustion and ventilation air.

If not installed, operated, and maintained in accordance with the manufacturer's instructions, this product could expose you to substances in fuel or fuel combustion which are known to the State of California to cause cancer, birth defects, or other reproductive harm.

Keep burner and control compartment clean. See installation and operating instructions accompanying appliance.

For additional information on operating your
Hearth & Home Technologies fireplace, please refer to www.fireplaces.com.

- Immediately call your gas supplier from a neighbor's phone. Follow the gas supplier's instructions.
 - If you cannot reach your gas supplier, call the fire department.
- C. DO NOT** use this appliance if any part has been under water. Immediately call a qualified service technician to inspect the appliance and to replace any part of the control system and any gas control which has been under water.

CAUTION:

Hot while in operation. **DO NOT** touch. Keep children, clothing, furniture, gasoline and other liquids having flammable vapors away.

DO NOT operate the appliance with fixed glass assembly removed, cracked or broken. Replacement of the fixed glass assembly should be done by a licensed or qualified service person.

NOT FOR USE WITH SOLID FUEL

For use with natural gas and propane. A conversion kit, as supplied by the manufacturer, shall be used to convert this appliance to the alternate fuel.

Also Certified for Installation in a Bedroom or a Bedsitting Room.

For assistance or additional information, consult a qualified installer, service agency or the gas supplier.

LIGHTING INSTRUCTIONS (IPI)

1. This appliance is equipped with an ignition device which automatically lights the burner. **DO NOT** try to light the burner by hand.

**GAS
VALVE**

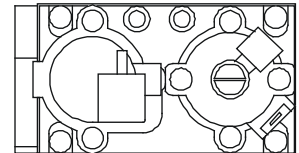

2. Wait five (5) minutes to clear out any gas. Then smell for gas, including near the floor. If you smell gas, **STOP!** Follow "B" in the Safety Information located on the left side of this label. If you do not smell gas, go to next step.
3. To light the burner:
Equipped with wall switch: Turn ON/OFF switch to ON.
Equipped with remote or wall control: Press ON or FLAME button.
Equipped with thermostat: Set temperature to desired setting.
4. If the appliance does not light after three tries, call your service technician or gas supplier.

TO TURN OFF GAS TO APPLIANCE

1. Equipped with wall switch: Turn ON/OFF switch to OFF.
Equipped with remote or wall control: Press OFF button.
Equipped with thermostat: Set temperature to lowest setting.
2. Service technician should turn off electric power to the control when performing service.

593-913G

Final inspection by _____

J. After Fireplace is Lit

Initial Break-in Procedure

- The fireplace should be run three to four hours continuously on high.
- Turn the fireplace off and allow it to completely cool.
- Remove fixed glass assembly. See Section 9.B.
- Clean fixed glass assembly. See Section 3.
- Replace the fixed glass assembly and run continuously on high an additional 12 hours.

This cures the materials used to manufacture the fireplace.

NOTICE! Open windows for air circulation during fireplace break-in.

- *Some people may be sensitive to smoke and odors.*
- *Smoke detectors may activate.*

K. Frequently Asked Questions

ISSUE	SOLUTIONS
Condensation on the glass	This is a result of gas combustion and temperature variations. As the fireplace warms, this condensation will disappear.
Blue flames	This is a result of normal operation and the flames will begin to yellow as the fireplace is allowed to burn for 20 to 40 minutes.
Odor from fireplace	When first operated, this fireplace may release an odor for the first several hours. This is caused by the curing of materials from manufacturing. Odor may also be released from finishing materials and adhesives used near the fireplace. These circumstances may require additional curing related to the installation environment.
Film on the glass	This is a normal result of the curing process of the paint. Glass should be cleaned within 3 to 4 hours of initial burning. A non-abrasive cleaner such as gas appliance glass cleaner may be necessary. See your dealer.
Metallic noise	Noise is caused by metal expanding and contracting as it heats up and cools down, similar to the sound produced by a furnace or heating duct. This noise does not affect the operation or longevity of the fireplace.
Power Outages (battery backup)	This appliance can operated on battery power in the event of a power outage. To access the battery pack, the decorative front, mesh and glass assembly must be removed. Refer to Section 12 for more details.
Wall above appliance feels hot to the touch.	No action necessary. This appliance ships with a non-combustible material attached. Specifications of the attached non-combustible material are listed in Section 1.E.

3 Maintenance and Service

Any safety screen or guard removed for servicing must be replaced prior to operating the fireplace.

When properly maintained, your fireplace will give you many years of trouble-free service. We recommend annual service by a qualified service technician.

A. Maintenance Tasks-Homeowner

Installation and repair should be done by a qualified service technician only. The fireplace should be inspected before use and at least annually by a professional service person.

The following tasks may be performed annually by the homeowner. If you are uncomfortable performing any of the listed tasks, please call your dealer for a service appointment.

More frequent cleaning may be required due to lint from carpeting or other factors. Control compartment, burner and circulating air passageway of the fireplace must be kept clean.

CAUTION! Risk of Burns! The fireplace should be turned off and cooled before servicing.

Glass Cleaning

Frequency: Seasonally

By: Homeowner

Tools Needed: Protective gloves, glass cleaner, drop cloth and a stable work surface.

CAUTION! Handle fixed glass assembly with care. Glass is breakable.

- Avoid striking, scratching or slamming glass
- Avoid abrasive cleaners
- **DO NOT** clean glass while it is hot
- Prepare a work area large enough to accommodate fixed glass assembly and door frame by placing a drop cloth on a flat, stable surface.

Note: Fixed glass assembly and gasketing may have residue that can stain carpeting or floor surfaces.

- Remove door or decorative front from fireplace and set aside on work surface.
- See Section 9.B for instructions to remove fixed glass assembly.
- Clean glass with a non-abrasive commercially available cleaner.
 - Light deposits: Use a soft cloth with soap and water
 - Heavy deposits: Use commercial fireplace glass cleaner (consult with your dealer)
- Carefully set fixed glass assembly in place on fireplace. Hold glass in place with one hand and secure glass latches with the other hand.
- Reinstall door or decorative front.

Doors, Surrounds, Fronts

Frequency: Annually

By: Homeowner

Tools needed: Protective gloves, stable work surface

- Assess condition of screen and replace as necessary.
- Inspect for scratches, dents or other damage and repair as necessary.
- Check that louvers are not blocked.
- Vacuum and dust surfaces.

Remote Control

Frequency: Seasonally

By: Homeowner

Tools needed: Replacement batteries and remote control instructions.

- Locate remote control transmitter and receiver.
- Verify operation of remote. Refer to remote control operation instructions for proper calibration and setup procedure.
- Place batteries as needed in remote transmitters and battery-powered receivers.
- Place remote control out of reach of children.

If not using your fireplace for an extended period of time (summer months, vacations/trips, etc), to prevent unintended operation:

- Remove batteries from remote controls.
- Unplug 6 volt adapter plug on IPI models.
- Remove battery backup from control module.

Venting

Frequency: Seasonally

By: Homeowner

Tools needed: Protective gloves and safety glasses.

- Inspect venting and termination cap for blockage or obstruction such plants, bird nests, leaves, snow, debris, etc.
- Verify termination cap clearance to subsequent construction (building additions, decks, fences, or sheds). See Section 6.
- Inspect for corrosion or separation.
- Verify weather stripping, sealing and flashing remains intact.
- Inspect draft shield to verify it is not damaged or missing.

B. Maintenance Tasks-Qualified Service Technician

To prevent inadvertent burner operation while servicing this appliance:

- Unplug DC regulator from junction box.
- Remove batteries from battery pack (if installed).
- Shut off gas supply to the appliance.

The following tasks must be performed by a qualified service technician.

Gasket Seal and Glass Assembly Inspection

Frequency: Annually

By: Qualified Service Technician

Tools needed: Protective gloves, drop cloth and a stable work surface.

- Inspect gasket seal and its condition.
- Inspect fixed glass assembly for scratches and nicks that can lead to breakage when exposed to heat.
- Confirm there is no damage to glass or glass frame. Replace as necessary.
- Verify that fixed glass assembly is properly retained and attachment components are intact and not damaged. Replace as necessary.

Logs

Frequency: Annually

By: Qualified Service Technician

Tools needed: Protective gloves.

- Inspect for damaged or missing logs. Replace as necessary. Refer to Section 14.E for log placement instructions.
- Verify correct log placement and no flame impingement causing sooting. Correct as necessary.

Firebox

Frequency: Annually

By: Qualified Service Technician

Tools needed: Protective gloves, sandpaper, steel wool, cloths, mineral spirits, primer and touch-up paint.

- Inspect for paint condition, warped surfaces, corrosion or perforation. Sand and repaint as necessary.
- Replace fireplace if firebox has been perforated.

Control Compartment and Firebox Top

Frequency: Annually

By: Qualified Service Technician

Tools needed: Protective gloves, vacuum cleaner, dust cloths

- Vacuum and wipe out dust, cobwebs, debris or pet hair. Use caution when cleaning these areas. Screw tips that have penetrated the sheet metal are sharp and should be avoided.
- Remove all foreign objects.
- Verify unobstructed air circulation.

Gas Pressure Information

Frequency: Upon initial installation and gas valve replacement or service.

By: Qualified Service Technician

Tools needed: Protective gloves, manometer, flashlight, screw driver set.

- Gas pressure taps are accessible by removing the decorative front and fixed glass assembly. Refer to section 11.A for information related to the gas valve and gas pressure settings.

Burner Ignition and Operation

Frequency: Annually

By: Qualified Service Technician

Tools needed: Protective gloves, vacuum cleaner, whisk broom, flashlight, voltmeter, indexed drill bit set, and a manometer.

- Verify burner is properly secured and aligned with pilot or igniter.
- Clean off burner top, inspect for plugged ports, corrosion or deterioration. Replace burner if necessary.
- Replace Glowing embers with new dime-size pieces. **DO NOT** block ports or obstruct lighting paths. See Figure 3.2.
- Verify batteries have been removed from battery back-up IPI systems to prevent premature battery failure or leaking.
- Check for smooth lighting and ignition carryover to all ports. Verify that there is no ignition delay.
- Inspect for lifting or other flame problems.
- Verify air shutter setting is correct. See Section 9 for required air shutter setting. Verify air shutter is clear of dust and debris.
- Inspect orifice for soot, dirt and corrosion. Verify orifice size is correct. See Service Parts List for proper orifice sizing.
- Verify manifold and inlet pressures. Adjust regulator as required.
- Inspect pilot flame pattern and strength. See Figure 3.1 for proper pilot flame pattern. Clean or replace orifice spud as necessary.
- Inspect IPI flame sensing rod for soot, corrosion and deterioration. Polish with fine steel wool or replace as required.
- Verify that there is not a short in flame sense circuit by checking continuity between pilot hood and flame sensing rod. Replace pilot as necessary.

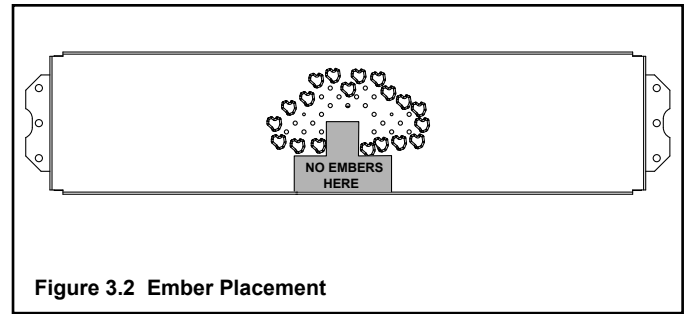

Figure 3.2 Ember Placement

- Place small pieces of ember material on burner top around burner ports.
- Do NOT press embers into burner ports.
- Do NOT place embers in the center area shown in Figure 3.2.



Figure 3.1 IPI Pilot Flame Patterns

4 Getting Started

Installer Guide

A. Typical Appliance System

NOTICE: Illustrations and photos reflect typical installations and are for design purposes only. Illustrations/diagrams are not drawn to scale. Actual product may vary from pictures in manual

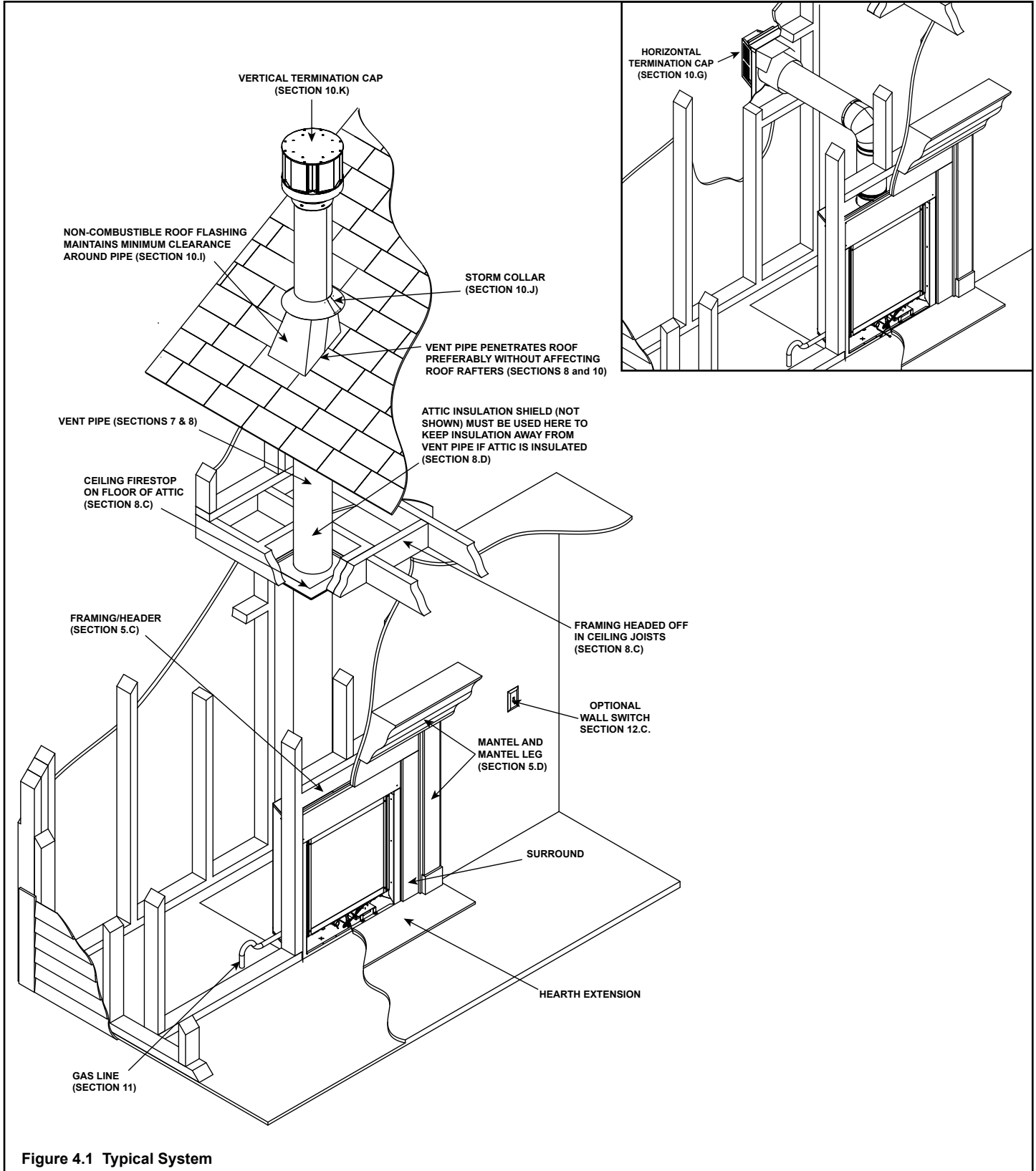

Figure 4.1 Typical System

B. Design and Installation Considerations

Heat & Glo direct vent gas appliances are designed to operate with all combustion air siphoned from outside of the building and all exhaust gases expelled to the outside of the building. No additional outside air source is required.

Installation **MUST** comply with local, regional, state and national codes and regulations. Consult insurance carrier, local building inspector, fire officials or authorities having jurisdiction over restrictions, installation inspection and permits.

Before installing, determine the following:

- Where the appliance is to be installed.
- The vent system configuration to be used.
- Gas supply piping requirements.
- Electrical wiring requirements.
- Framing and finishing details.
- Whether optional accessories—devices such as a fan, wall switch, or remote control—are desired.

Improper installation, adjustment, alteration, service or maintenance can cause injury or property damage. For assistance or additional information, consult a qualified service technician, service agency or your dealer.

C. Tools and Supplies Needed

Before beginning the installation be sure that the following tools and building supplies are available.

- | | |
|--------------|-----------------------------------|
| Tape measure | Framing material |
| Pliers | Hammer Phillips screwdriver |
| Gloves | Framing square |
| Voltmeter | Electric drill and bits (1/4 in.) |
| Plumb line | Safety glasses |
| Level | Reciprocating saw |
| Manometer | Flat blade screwdriver |

Non-corrosive leak check solution

High temperature caulking material (150 °C minimum continuous exposure rating)

1/2 - 3/4 in. length, #6 or #8 Self-drilling screws

One 1/4 in. female connection (for optional fan).

D. Inspect Appliance and Components

- Carefully remove the appliance and components from the packaging.
- The vent system components and decorative doors and fronts may be shipped in separate packages.
- If packaged separately, the log set and appliance grate must be installed.
- Report to your dealer any parts damaged in shipment, particularly the condition of the glass.
- **Read all of the instructions before starting the installation. Follow these instructions carefully during the installation to ensure maximum safety and benefit.**

WARNING! Risk of Fire or Explosion! Damaged parts could impair safe operation. DO NOT install damaged, incomplete or substitute components. Keep appliance dry.

Hearth & Home Technologies disclaims any responsibility for, and the warranty will be voided by, the following actions:

- Installation and use of any damaged appliance or vent system component.
- Modification of the appliance or vent system.
- Installation other than as instructed by Hearth & Home Technologies.
- Improper positioning of the gas logs or the glass door.
- Installation and/or use of any component part not approved by Hearth & Home Technologies.

Any such action may cause a fire hazard.

WARNING! Risk of Fire, Explosion or Electric Shock! DO NOT use this appliance if any part has been under water. Call a qualified service technician to inspect the appliance and to replace any part of the control system and/or gas control which has been under water.

5 Framing and Clearances

A. Selecting Appliance Location

When selecting a location for the appliance it is important to consider the required clearances to walls (see Figure 5.1).

WARNING! Risk of Fire or Burns! Provide adequate clearance around air openings and for service access. Due to high temperatures, the appliance should be located out of traffic and away from furniture and draperies.

NOTICE: Illustrations reflect typical installations and are FOR DESIGN PURPOSES ONLY. Illustrations/diagrams are not drawn to scale. Actual installation may vary due to individual design preference.

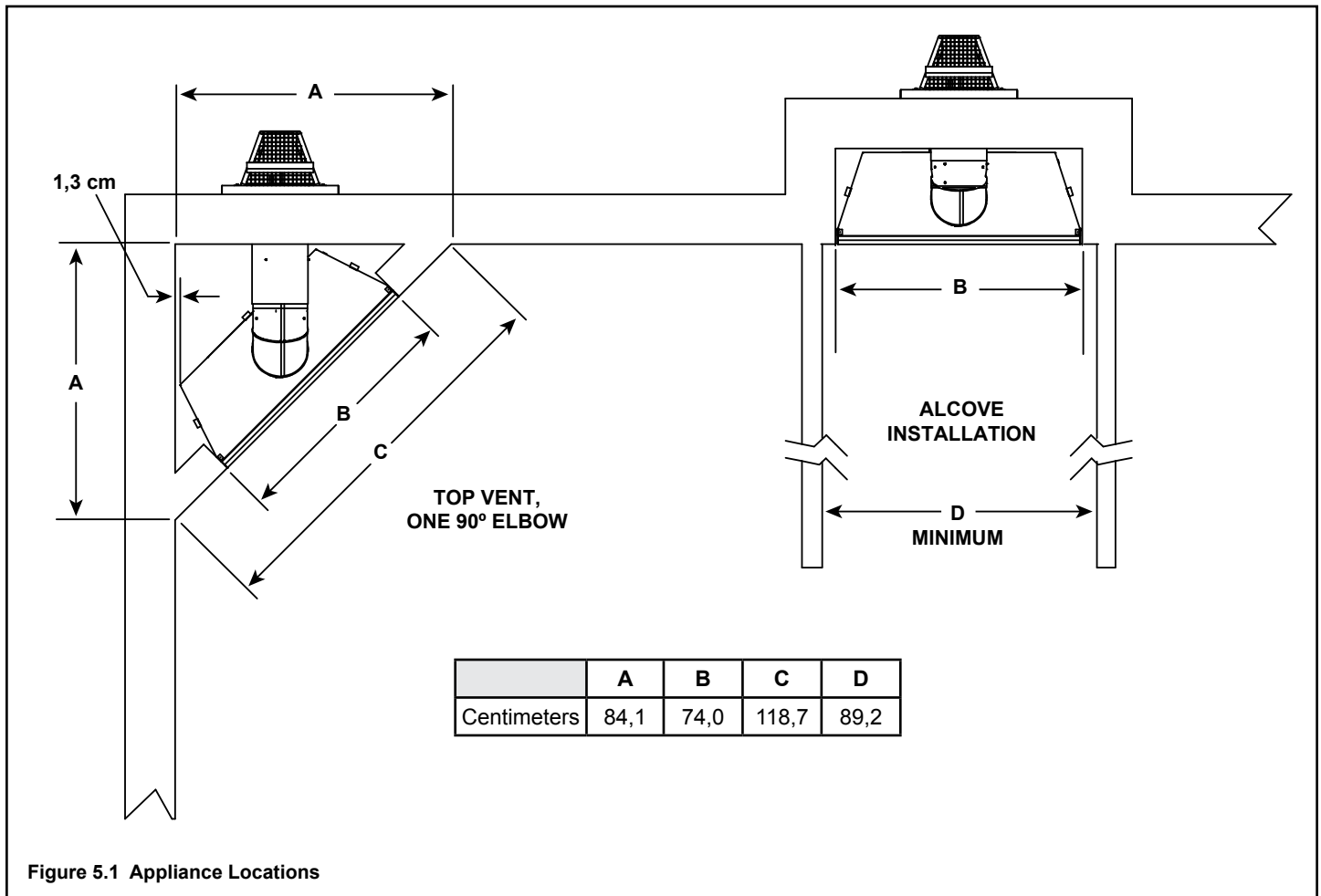

Figure 5.1 Appliance Locations

B. Constructing the Appliance Chase

A chase is a vertical box-like structure built to enclose the gas appliance and/or its vent system. In cooler climates the vent should be enclosed inside the chase.

NOTICE: Treatment of ceiling firestops and wall shield firestops and construction of the chase may vary with the type of building. These instructions are not substitutes for the requirements of local building codes. Therefore, you **MUST** check local building codes to determine the requirements to these steps.

Chases should be constructed in the manner of all outside walls of the home to prevent cold air drafting problems. The chase should not break the outside building envelope in any manner.

Walls, ceiling, base plate and cantilever floor of the chase should be insulated. Vapor and air infiltration barriers should be installed in the chase as per regional codes for the rest of the home. Additionally, in regions where cold air infiltration may be an issue, the inside surfaces may be sheetrocked and taped for maximum air tightness.

NOTICE: Measure fireplace dimensions and verify framing methods and wall covering details, before framing construction begins.

To further prevent drafts, the wall shield and ceiling firestops should be caulked with high temperature caulk (150 °C minimum continuous exposure rating) to seal gaps. Gas line holes and other openings should be caulked with high temperature caulk (150 °C minimum continuous exposure rating) or stuffed with unfaced insulation. If the appliance is being installed on a cement surface, a layer of plywood may be placed underneath to prevent conducting cold up into the room.

C. Clearances

NOTICE: Install appliance on hard metal or wood surfaces extending full width and depth. **DO NOT** install directly on carpeting, vinyl, tile or any combustible material other than wood.

WARNING! Risk of Fire! Maintain specified air space clearances to appliance and vent pipe:

- Insulation and other materials must be secured to prevent accidental contact.
- The chase must be properly blocked to prevent blown insulation or other combustibles from entering and making contact with fireplace or chimney.
- Failure to maintain airspace may cause overheating and a fire.

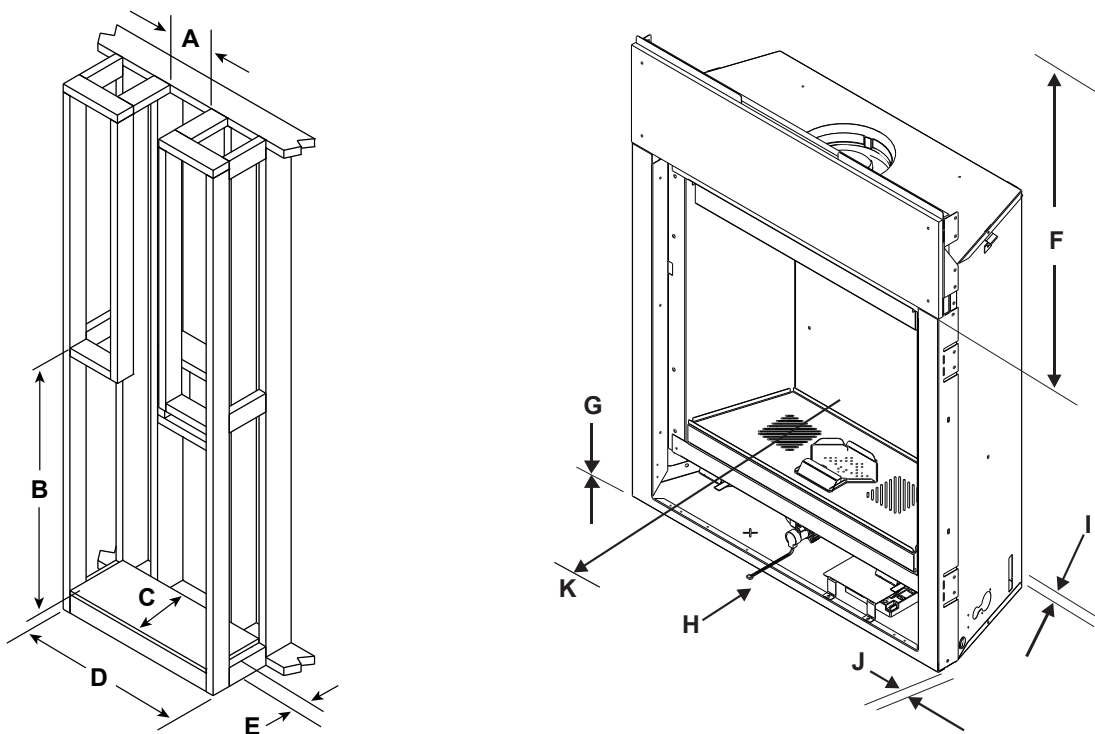

CLEARANCES TO COMBUSTIBLES:

	A	B	C	D	E	F	G	H	I	J	K
	Rough Opening (Flue Pipe)	Rough Opening (Height)	Rough Opening (Depth)	Rough Opening (Width)	Minimum Platform Height	Clearance to Ceiling	Non-Combustible Floor	Combustible Flooring	Behind Appliance	Sides of Appliance	Front of Appliance
cm	21,9	111,8	29,2	75,2	7,6	71,1	0	0	1,3	1,3	91,4

Figure 5.2 Clearances to Combustibles

D. Mantel and Wall Projections

WARNING! Risk of Fire! Comply with all minimum clearances as specified. Framing or finishing material closer than the minimums listed must be constructed entirely of non-combustible materials (i.e., steel studs, concrete board, etc).

Combustible Mantels

No mantels are allowed when using Studio-CE fronts.

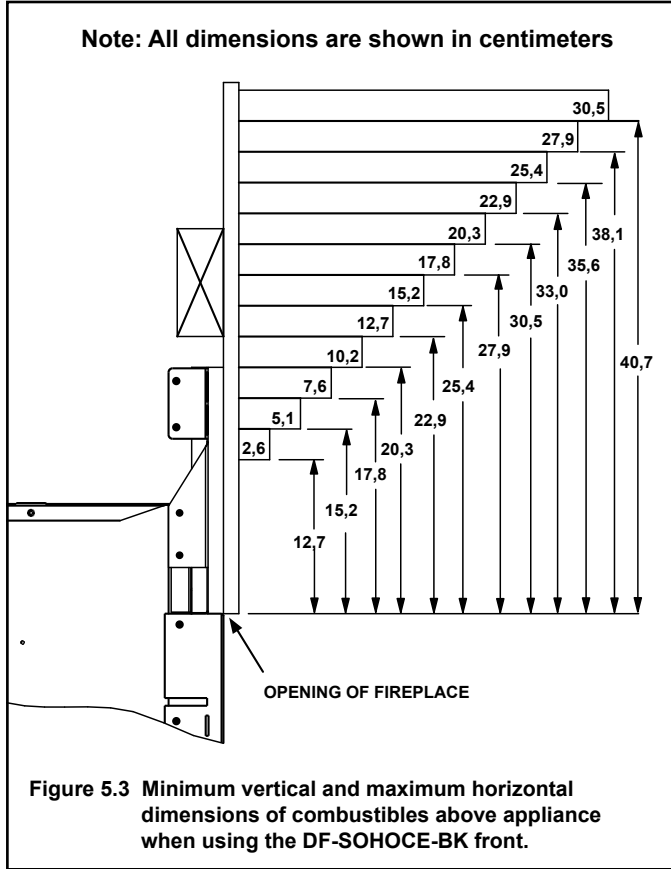

Combustible Mantel Legs or Wall Projections

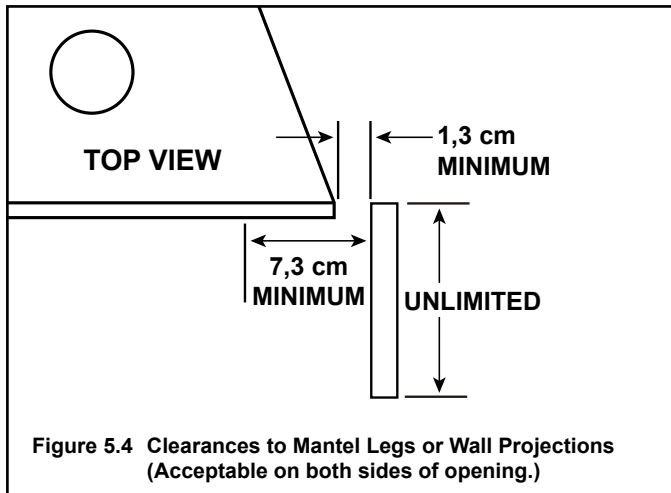

6 Termination Locations

A. Vent Termination Minimum Clearances

WARNING

Fire Risk.
Maintain vent clearance to combustibles as specified.

- DO NOT** pack air space with insulation or other materials.

Failure to keep insulation or other materials away from vent pipe may cause overheating and fire.

Angle	H (Min.) cm
0°-26.6°	30*
26.6°-30.3°	38*
30.3°-33.7°	46*
33.7°-36.9°	61*
36.9°-39.8°	76
39.8°-42.5°	99
42.5°-45.0°	122
45.0°-49.4°	152
49.4°-53.1°	183
53.1°-56.3°	213
56.3°-59.0°	229
59.0°-60.3°	244

*.91 M minimum in snow regions

Figure 6.1 Minimum Height From Roof To Lowest Discharge Opening

A	B
15,2 cm (minimum) up to 50,8 cm	45,7 cm minimum
50,8 cm and over	0 mm minimum

* If using decorative cap cover(s), this distance may need to be increased. Refer to the installation instructions supplied with the decorative cap cover.

** In a staggered installation with both gas and wood or fuel oil termination, the wood or fuel oil termination cap must be higher than the gas termination cap.

Figure 6.2 Staggered Termination Caps

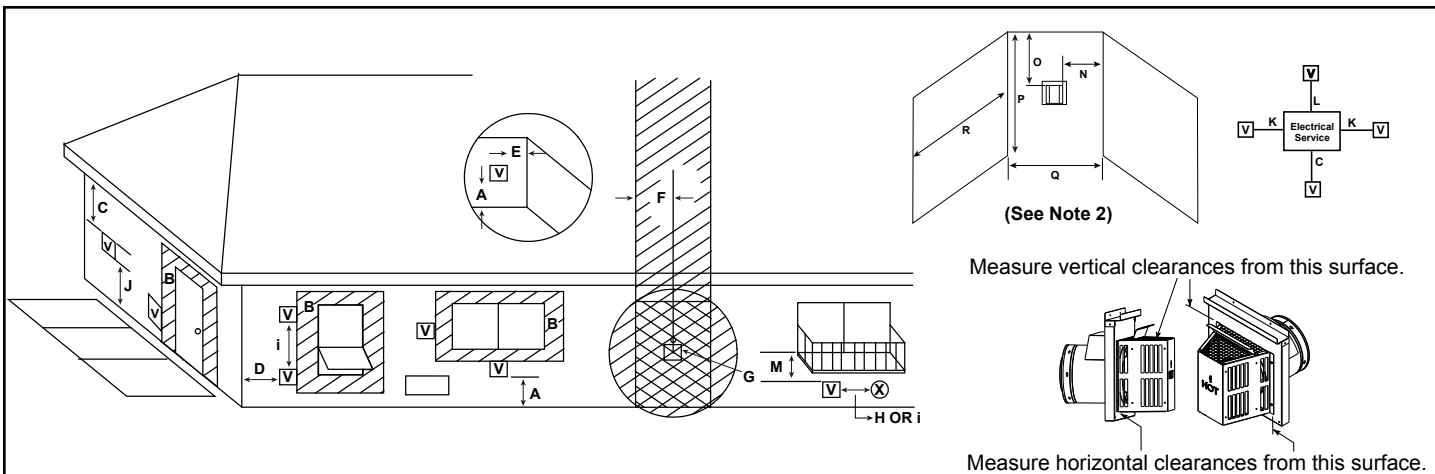

V = VENT TERMINAL **X** = AIR SUPPLY INLET = AREA WHERE TERMINAL IS NOT PERMITTED

- A = 31 cmclearances above grade, veranda, porch, deck or balcony (See Note 1)
- B = 31 cmclearances to window or door that may be opened, or to permanently closed window. (Glass)
- C = 46 cmvertical clearance to unventilated soffit or to ventilated soffit located above the terminal
76 cm.....for vinyl clad soffits and below electrical service
- D = 23 cmclearance to outside corner
- E = 15 cmclearance to inside corner
- F = 91 cmnot to be installed above a gas meter/regulator assembly within 3 feet (90 cm) horizontally from the center-line of the regulator
- G = 1,8 mclearance to gas service regulator flue outlet
- H = 31 cmclearance to non-mechanical air supply inlet to building or the combustion air inlet to any other appliance (See Note 2)
- i = 1,8 mclearance to a mechanical (powered) air supply inlet (See Note 2)

- J** = 2,13 m clearance above paved sidewalk or a paved driveway located on **public** property (See Note 1)
- K = 15 cmclearance from sides of electrical service (See Note 5)
- L = 31 cmclearance above electrical service (See Note 5)

Covered Alcove Applications

- M*** = 46 cm clearance under veranda, porch, deck, balcony or overhang
107 cm vinyl
- N = 15 cm non-vinyl sidewalls
31 cm vinyl sidewalls
- O = 46 cm non-vinyl soffit and overhang
107 cm vinyl soffit and overhang
- P = 2.4 m

	Q_{MIN}	R_{MAX}
1 cap	91 cm	2 x Q _{ACTUAL}
2 caps	1,8 m	1 x Q _{ACTUAL}
3 caps	2,7 m	2/3 x Q _{ACTUAL}
4 caps	3,7 m	1/2 x Q _{ACTUAL}
Q_{MIN} = # termination caps x 3 R_{MAX} = (2 / # termination caps) x Q_{ACTUAL}		

** a vent shall not terminate directly above a sidewalk or paved driveway which is located between two single family dwellings and serves both dwellings.

*** only permitted if veranda, porch, deck or balcony is fully open on a minimum of 2 sides beneath the floor, or meets Note 2.

Note 1: On private property where termination is less than 2.1 m above a sidewalk, driveway, deck, porch, veranda or balcony, use of a listed cap shield is suggested. (See vents components page)

Note 2: Termination in a covered alcove space (spaces open only on one side and with an overhang) are permitted with the dimensions specified for vinyl or non-vinyl siding and soffits. **1.** There must be .91 m minimum between termination caps. **2.** All mechanical air intakes within 3 m of a termination cap must be a minimum of .91 m below the termination cap. **3.** All gravity air intakes within .91 m of a termination cap must be a minimum of .30 m below the termination cap.

Note 3: Local codes or regulations may require different clearances.

Note 4: Termination caps may be hot. Consider their proximity to doors or other traffic areas.

Note 5: Location of the vent termination must not interfere with access to the electrical service.

Vent system termination is **NOT** permitted in screened porches.

Vent system termination is permitted in porch areas with two or more sides open. You must follow all side walls, overhang and ground clearances as stated in the instructions.

Heat & Glo assumes no responsibility for the improper performance of the appliance when the venting system does not meet these requirements.

Figure 6.3 Minimum Clearances for Termination

7 Vent Information and Diagrams

A. Approved Pipe

This appliance is approved for use with Hearth & Home Technologies SLP venting systems. Refer to Section 16.B for vent component information.

DO NOT mix pipe, fittings or joining methods from different manufacturers.

The pipe is tested to be run inside an enclosed wall. There is no requirement for inspection openings at each joint within the wall.

WARNING! Risk of Fire or Asphyxiation. This appliance requires a separate vent. **DO NOT** vent to a pipe serving a separate solid fuel burning appliance.

B. Vent Table Key

The abbreviations listed in this vent table key are used in the vent diagrams.

Symbol	Description
V ₁	First section (closest to appliance) of vertical length
V ₂	Second section of vertical length
H ₁	First section (closest to appliance) of horizontal length
H ₂	Subsequent sections of horizontal length

C. Use of Elbows

Diagonal runs have both vertical and horizontal vent aspects when calculating the effects. Use the rise for the vertical aspect and the run for the horizontal aspect (see Figure 7.1).

Two 45° elbows may be used in place of one 90° elbow. On 45° runs, one foot of diagonal is equal to 21,6 cm horizontal run and 21,6 cm vertical run. A length of straight pipe is allowed between two 45° elbows (see Figure 7.1).

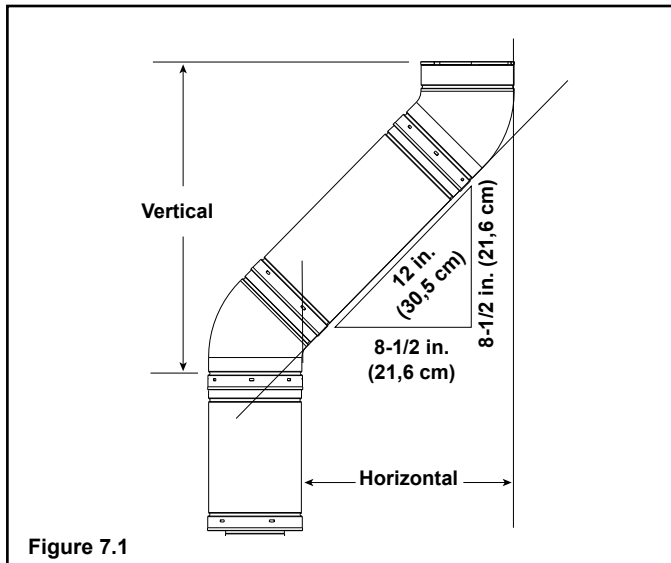

Figure 7.1

D. Measuring Standards

Vertical and horizontal measurements listed in the vent diagrams were made using the following standards.

- Pipe measurements are shown using the effective length of pipe (see Figure 7.2).
- Measurements are made from the appliance outer wrap, not from the standoffs.
- Horizontal terminations are measured to the outside mounting surface (flange of termination cap).
- Vertical terminations are measured to bottom of termination cap.
- Horizontal pipe installed level with no rise.

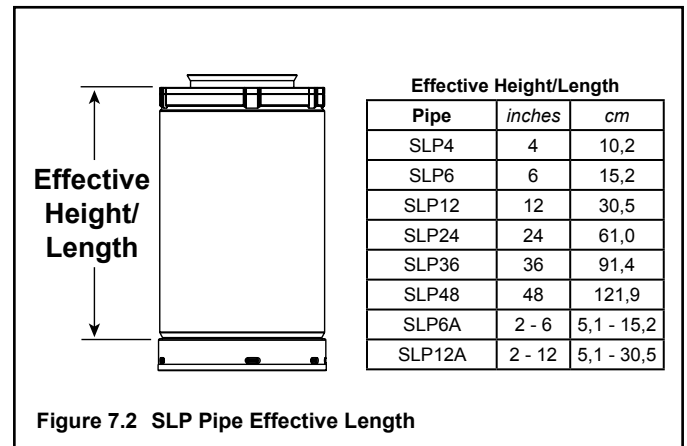

Figure 7.2 SLP Pipe Effective Length

E. Flue Diagrams

General Rules:

- When penetrating a combustible wall, a wall shield firestop must be installed.
- When penetrating a combustible ceiling, a ceiling firestop must be installed.
- Horizontal runs of vent do not require vertical rise; horizontal runs may be level.

Top Vent - Horizontal Termination

One Elbow

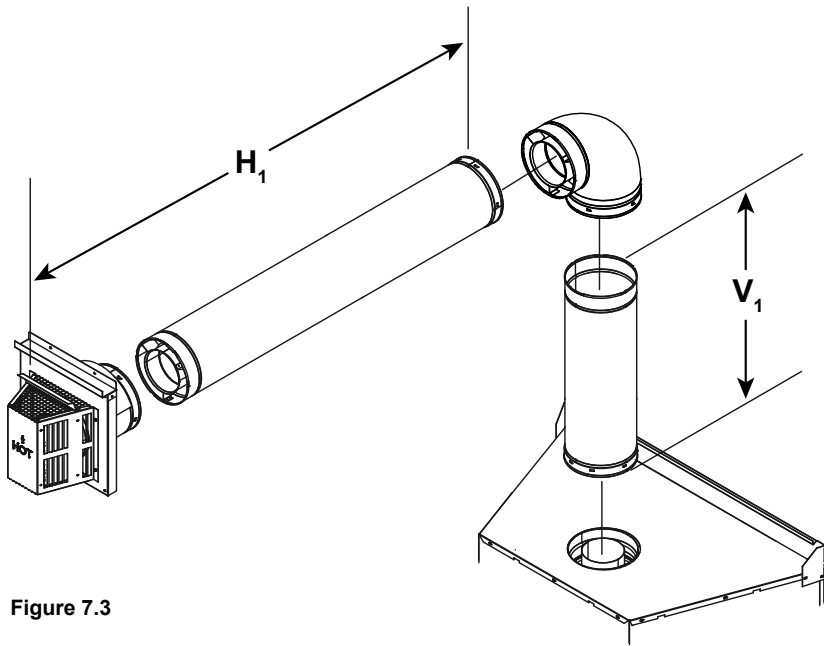

Figure 7.3

V_1 Minimum		H_1 Maximum	
Elbow only		2 ft.	61 cm
1 ft.	30,5 cm	2-1/2 ft.	76,2 cm
2 ft.	61 cm	5-1/2 ft.	1,68 m
3 ft.	91,4 cm	9 ft.	2,74 m
4 ft.	1,22 m	12 ft.	3,66 m
5 ft.	1,52 m	15 ft.	4,57 m
$V_1 + H_1$ Maximum = 38 ft. (11,58 m)			
H_1 Maximum = 15 ft. (4,57 m)			

Two Elbows

V_1 Minimum		$H_1 + H_2$ Maximum	
Elbow only		Not Allowed	
1 ft.	30,5 cm	2 ft.	61 cm
2 ft.	61 cm	5 ft.	1,52 m
3 ft.	91,4 cm	8 ft.	2,44 m
4 ft.	1,22 m	11 ft.	3,35 m
5 ft.	1,52 m	14 ft.	4,27 m
$V_1 + H_1 + H_2$ Maximum = 38 ft. (11,58 m)			
$H_1 + H_2$ Maximum = 14 ft. (4,27 m)			

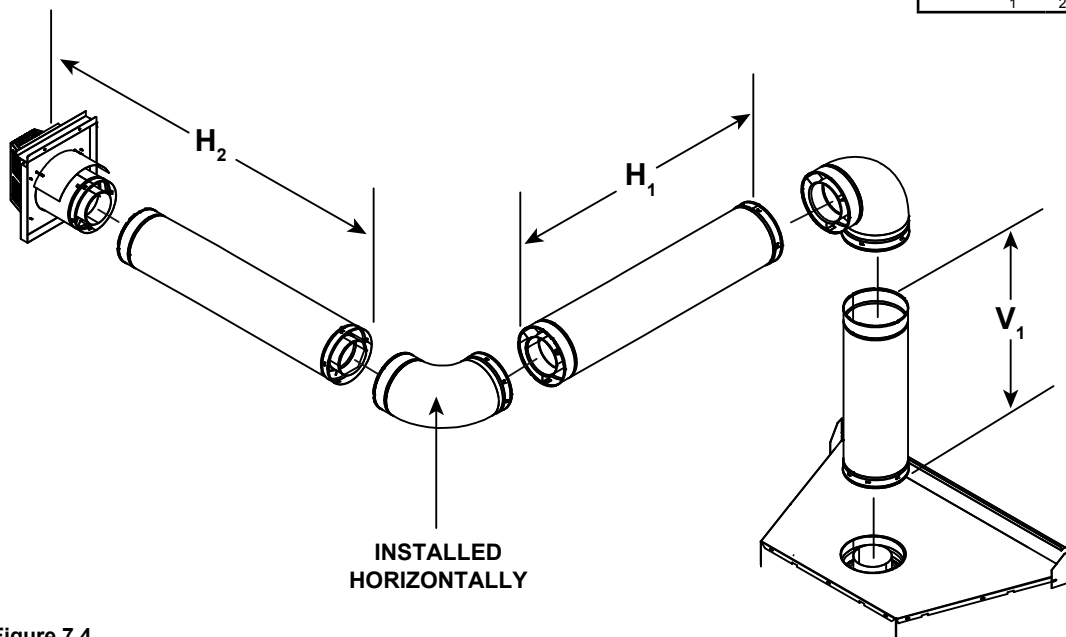

Figure 7.4

Top Vent - Horizontal Termination - (continued)

Three Elbows

Note: A 15,2 cm section of straight flue must be attached to the fireplace before a 90° elbow.

V ₁ Minimum		H ₁ Maximum		V ₂ Minimum		H ₂ Maximum	
6 in.	15,2 cm	1 ft.	30,5 cm	1 ft.	30,5 cm	1 ft.	30,5 cm
1 ft.	30,5 cm	2 ft.	61 cm	2 ft.	61 cm	2 ft.	61,0 cm
2 ft.	61 cm	2 ft.	61 cm	3 ft.	91,4 cm	4 ft.	1,22 m
3 ft.	91,4 cm	3 ft.	91,4 cm	4 ft.	1,22 m	6 ft.	1,83 m
4 ft.	1,22 m	4 ft.	1,22 m	5 ft.	1,52 m	8 ft.	2,44 m*
5 ft.	1,52 m	6 ft.	1,83 m	6 ft.	1,83 m	12 ft.	3,66 m
*H ₁ = 6 ft. (1,83 m) Maximum *H ₁ + H ₂ = 12 ft. (3,66 m) Maximum V ₁ + V ₂ = 32 ft. (9,75 m) Maximum V ₁ + V ₂ + H ₁ + H ₂ = 36 ft. (10,97 m) Maximum							

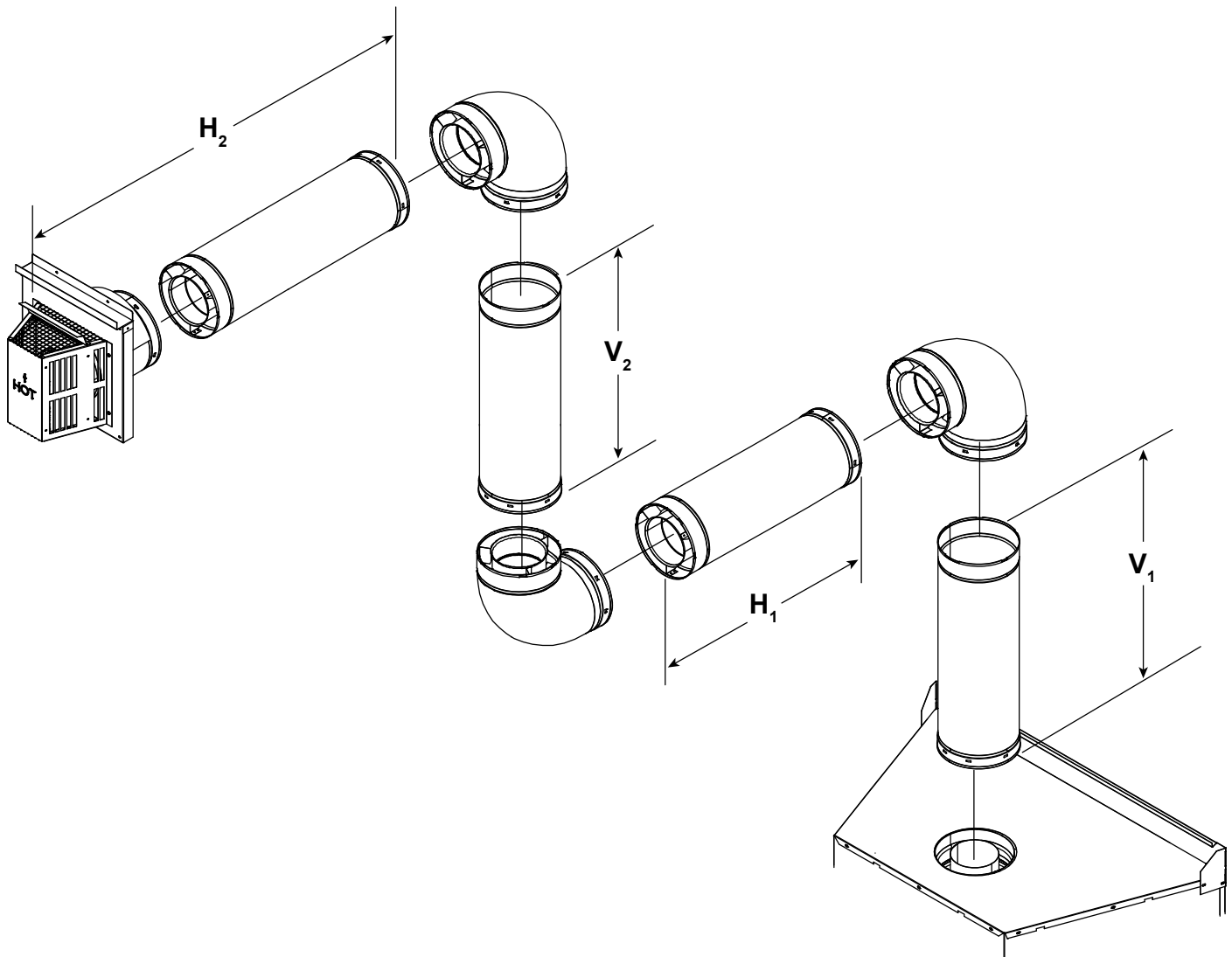

Figure 7.5

Top Vent - Vertical Termination

MODEL	FLUE TERMINATION APPROVALS
SOHO-CEB	SLP-TVHW

This model is approved to use SLP Series flue pipe components. A **SLP-TVHW** vertical Termination Cap must be used to terminate flue systems in a vertical position.

Approved flue system components are labeled for identification. **NO OTHER FLUE SYSTEMS OR COMPONENTS MAY BE USED.** Detailed installation instructions are included with each flue termination kit and should be used in conjunction with this manual.

WARNING! Risk of Fire! This gas appliance and flue assembly must be flued directly to the outside and must never be attached to a chimney serving a separate solid fuel burning appliance. Each gas appliance must use a separate flue system-common flue systems are prohibited.

WARNING! Risk of Fire! DO NOT apply combustible materials beyond the minimum clearances. Comply with all minimum clearances to combustibles as specified in this manual. Overlapping material could ignite and will interfere with proper operation of doors and louvers.

- Horizontal sections 3 inches (7,62 cm) from the top of the pipe.
- Horizontal sections 2-1/2 inches (6,35 cm) at wall shield firestops.
- Horizontal sections 1 inches (2,54 cm) from sides and bottom of the pipe.
- Vertical sections 1 inches (2,54 cm) on all sides of pipe.

Failure to keep insulation or other material away from vent pipe may cause over heating and fire.

For alternative installations, other than depicted, contact your dealer for further information.

Straight Up Vertical Flue System

Figure 7.6 shows straight up vertical flue system approved for use on this model.

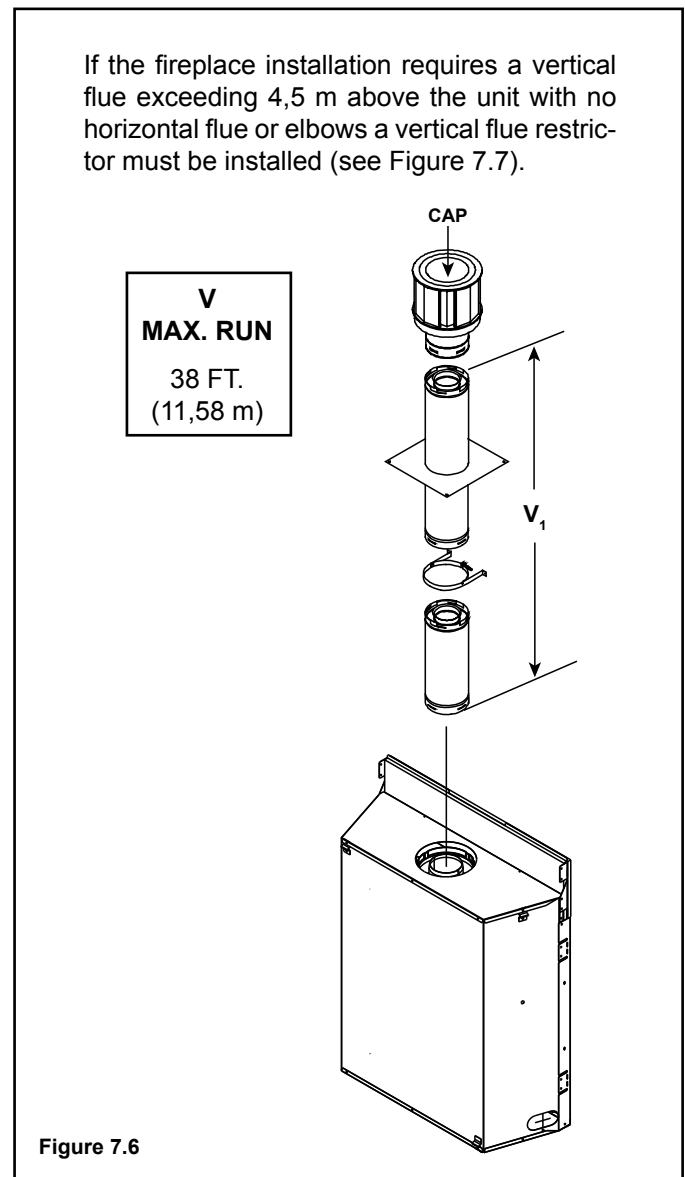

Top Vent - Vertical Termination - (continued)

No Elbow

$V_1 = 38$ ft. Max. (11.58 m)

$V_1 = 3$ ft. Min. (91,4 cm)

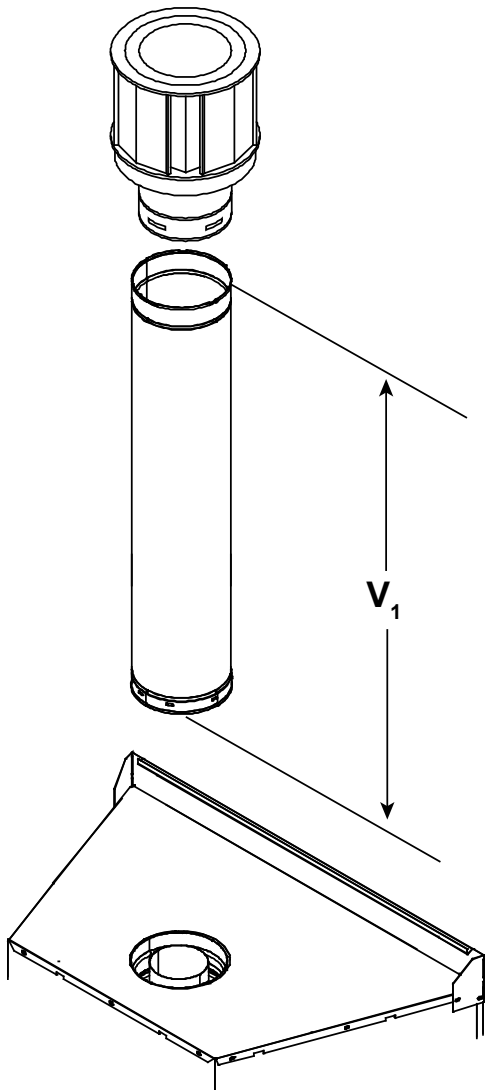

Note: The vertical termination baffle should be used for runs of 10 feet (3,05 m) or greater.

The vertical restrictor has a break away portion that creates a larger hole. If venting 10-18 feet (3,05 m - 5,49 m), the break away portion **MUST** be removed and the larger hole must be used. If venting over 18 feet (5,49 m), the break away portion should be left in place and the small hole should be used.

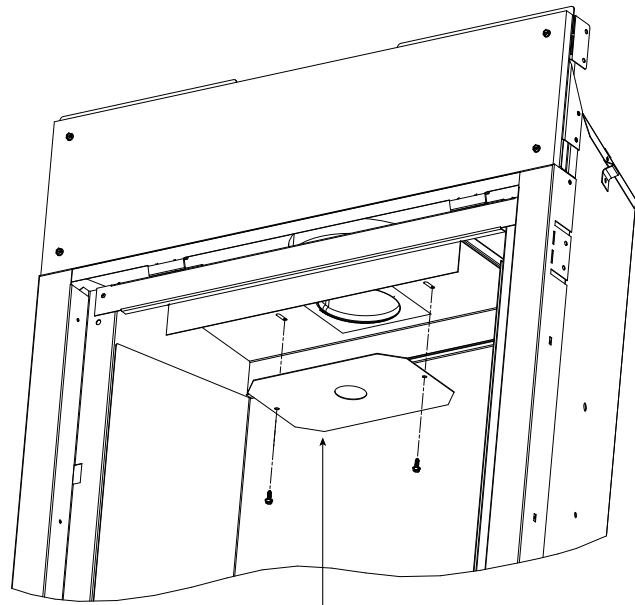

VERTICAL TERMINATION Baffle

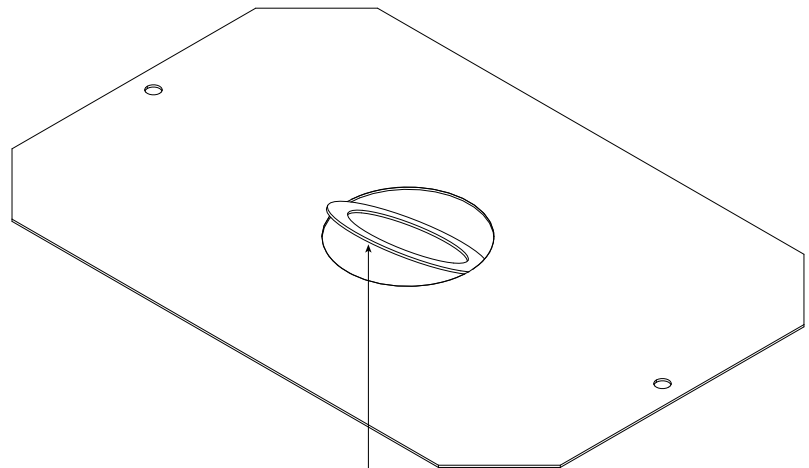

BREAK AWAY PORTION

Figure 7.7

MODEL
SOHO-CEB

FLUE TERMINATION APPROVALS
SLP-TRAP2 HORIZONTAL TERMINATION CAP
SLP-TVHW VERTICAL TERMINATION CAP
DVP-FBHT HORIZONTAL TERMINATION CAP

Flue System Approvals And Installations

These models have flue starting collars on both the top and the back of the unit. Depending upon the installation, decide which ONE set of starting collars will be used to attach the flue system. The starting collar sealing cap must remain on the starting collar NOT used.

These models use SLP series direct flue components.

Approved flue system components are labeled for identification. **NO OTHER FLUEING SYSTEMS OR COMPONENTS MAY BE USED.** Detailed installation instructions are included with each flue termination kit and should be used in conjunction with this *manual*. Figure 7.8 shows flue system components and terminations.

Identifying Flue Components

The flue systems installed on this gas fireplace may include one, two, or three 90° elbow assemblies. The relationships of vertical rise to horizontal run in flue configurations using 90° elbows **MUST BE** strictly adhered to. The rise to run relationships are shown in the flueing drawings and tables on the next few pages.

WARNING! Risk of Fire! This gas appliance and flue as-

sembly must flue directly to the outside and must never be attached to a chimney serving a separate solid fuel burning appliance. Each gas appliance must use a separate flue system—common flue systems are prohibited.

WARNING! Risk of Fire! DO NOT apply combustible materials beyond the minimum clearances. Comply with all minimum clearances to combustibles as specified in this manual. Overlapping material could ignite and will interfere with proper operation of doors and louvers.

- Horizontal sections 3 inches (7,62 cm) from the top of the pipe.
- Horizontal sections 2-1/2 inches (6,35 cm) at wall shield firestops.
- Horizontal sections 1 inches (2,54 cm) from sides and bottom of the pipe.
- Vertical sections 1 inches (2,54 cm) on all sides of pipe.

Failure to keep insulation or other material away from vent pipe may cause over heating and fire.

For alternative installations, other than depicted, contact your dealer for further information.

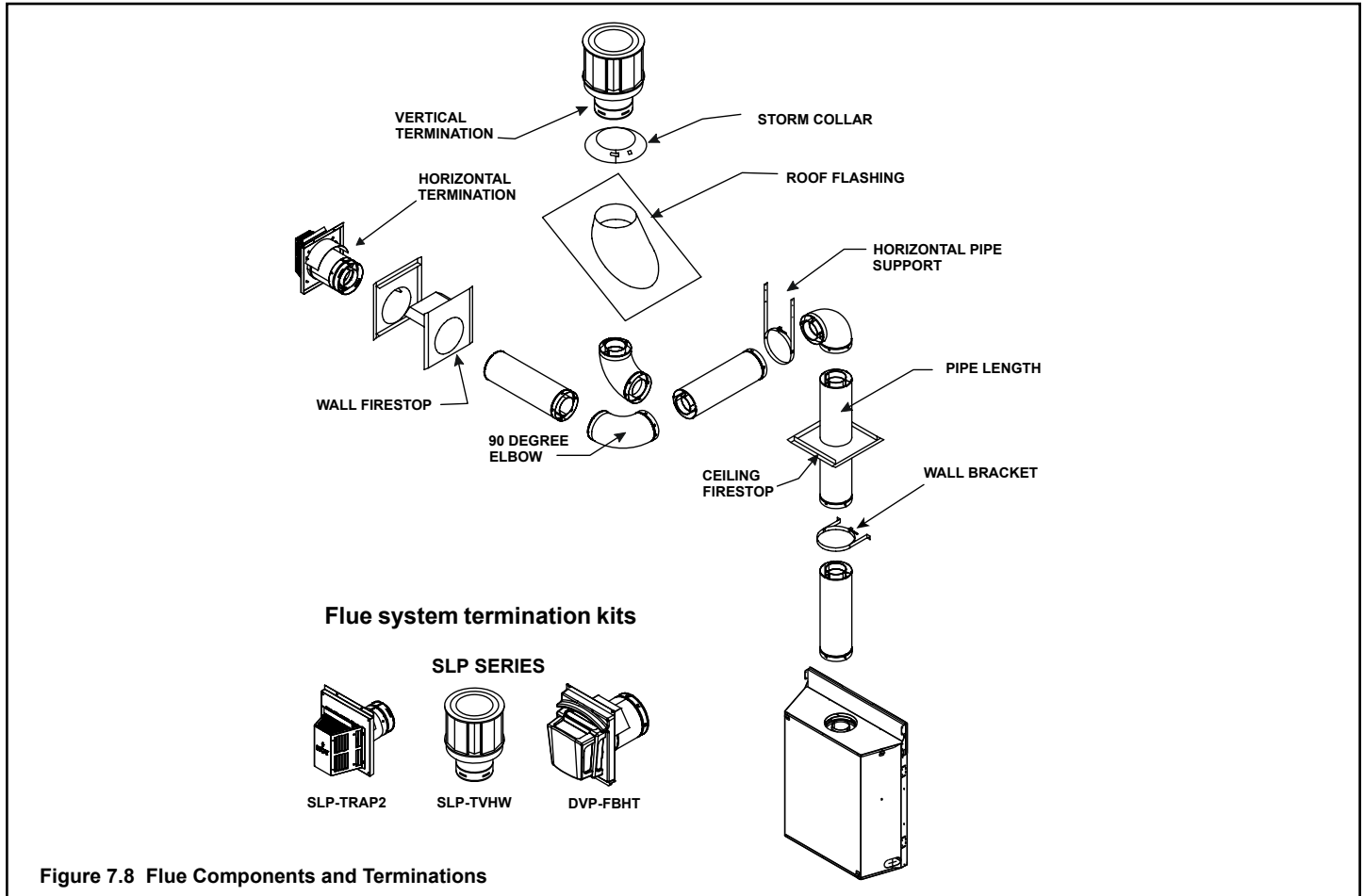
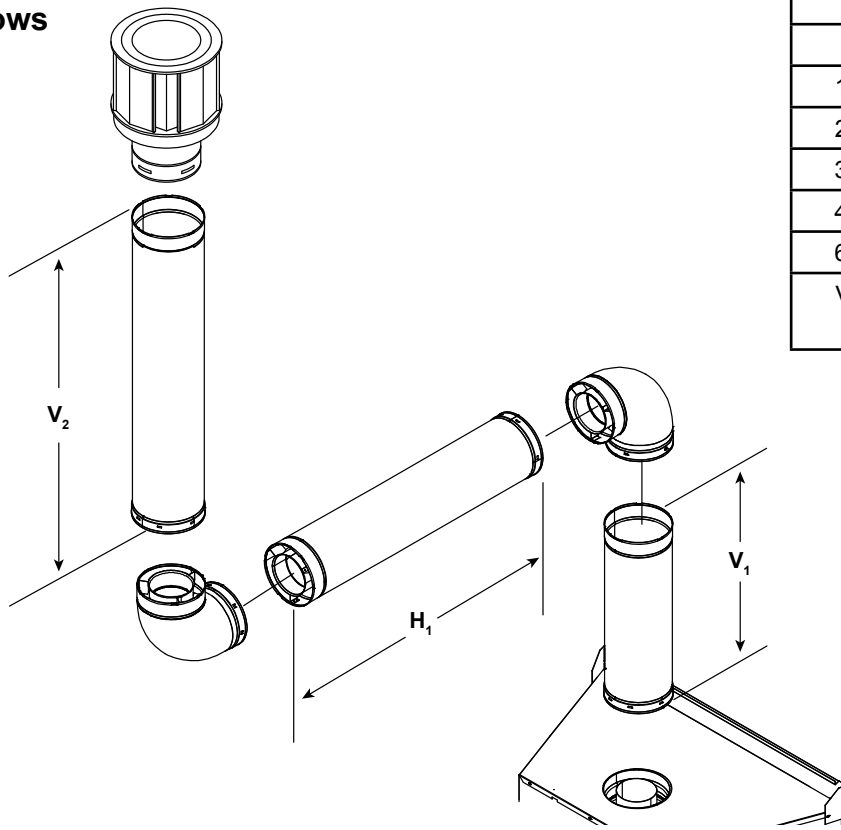

Figure 7.8 Flue Components and Terminations

Top Vent - Vertical Termination - (continued)

Two Elbows



V₁ Minimum		H₁ Maximum	
Elbow only		1-1/2 ft.	45,7 cm
1 ft.	30,5 cm	3 ft.	91,4 cm
2 ft.	61 cm	4 ft.	1,22 m
3 ft.	91,4 cm	6 ft.	1,83 m
4 ft.	1,22 m	8 ft.	2,44 m
6 ft.	1,83 m	15 ft.	4,57 m
V ₁ + V ₂ + H ₁ Maximum = 38 ft. (11,58 m)			
H ₁ + H ₂ Maximum = 15 ft. (4,57 m)			

Figure 7.9

Three Elbows

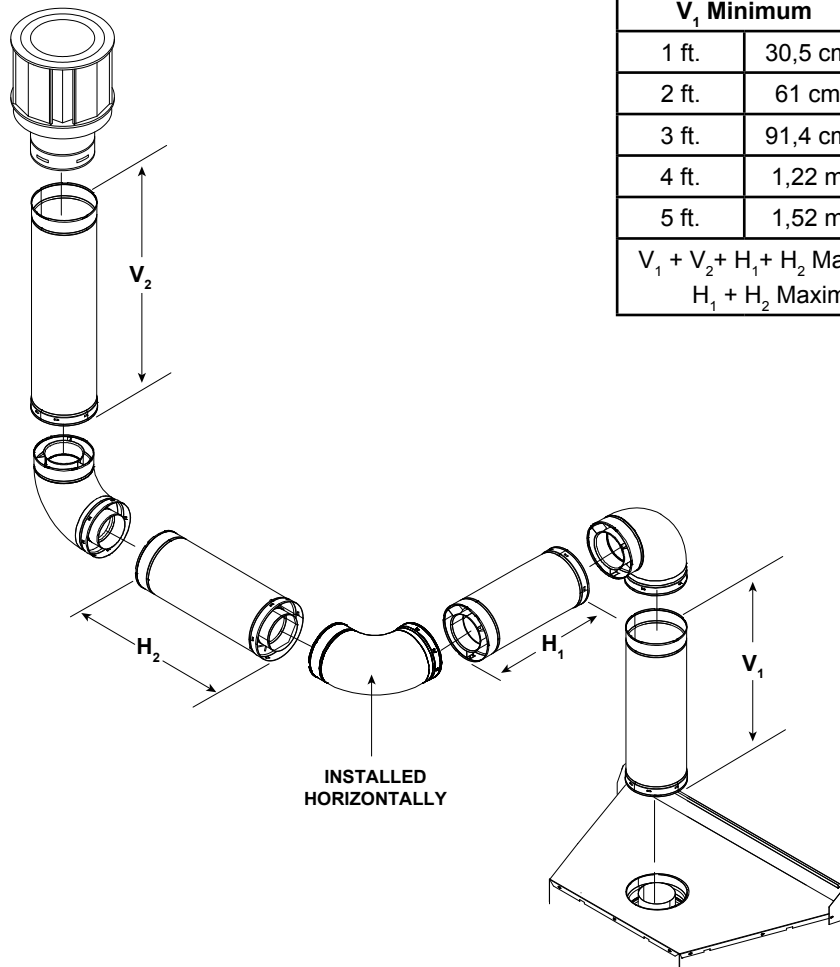

V₁ Minimum		H₁ + H₂ Maximum	
1 ft.	30,5 cm	2 ft.	61 cm
2 ft.	61 cm	3 ft.	91,4 cm
3 ft.	91,4 cm	5 ft.	1,52 m
4 ft.	1,22 m	7 ft.	2,13 m
5 ft.	1,52 m	14 ft.	4,27 m
V ₁ + V ₂ + H ₁ + H ₂ Maximum = 38 ft. (11,58 m)			
H ₁ + H ₂ Maximum = 14 ft. (4,27 m)			

Figure 7.10

8 Vent Clearances and Framing

A. Pipe Clearances to Combustibles

WARNING! Risk of Fire! Maintain air space clearance to vent. DO NOT pack insulation or other combustibles:

- Between ceiling firestops
- Between wall shield firestops
- Around vent system

Failure to keep insulation or other material away from vent pipe may cause over heating and fire.

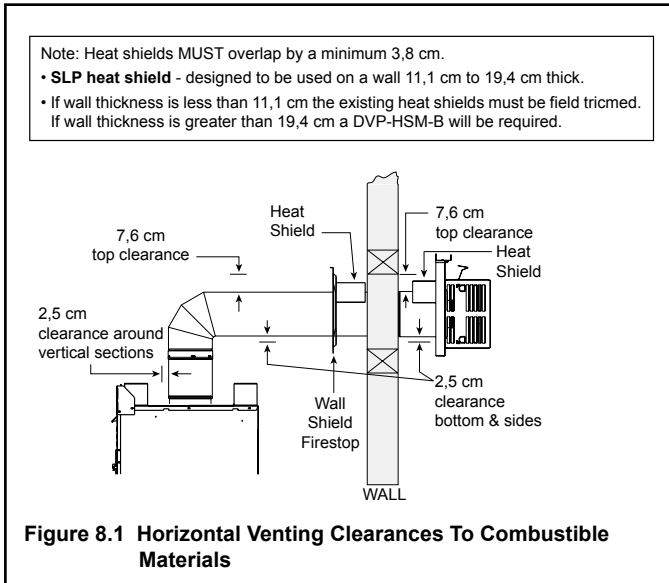

B. Wall Penetration Framing

Combustible Wall Penetration

Whenever a combustible wall is penetrated, you must frame a hole for the wall shield firestop(s). The wall shield firestop maintains minimum clearances and prevents cold air infiltration.

- The opening must be framed on all four sides using the same size framing materials as those used in the wall construction.
- SLP pipe - A wall shield firestop must be placed on each side of an interior wall. A minimum 1-1/2 inch (3,8 cm) overlap of attached heat shields must be maintained.
- See Section 10.G for information for regarding the installation of a horizontal termination cap.

Non-Combustible Wall Penetration

If the hole being penetrated is surrounded by noncombustible materials such as concrete, a hole with diameter one inch greater than the pipe is acceptable.

Whenever a non-combustible wall is penetrated, the wall shield firestop is only required on one side and no heat shield is necessary.

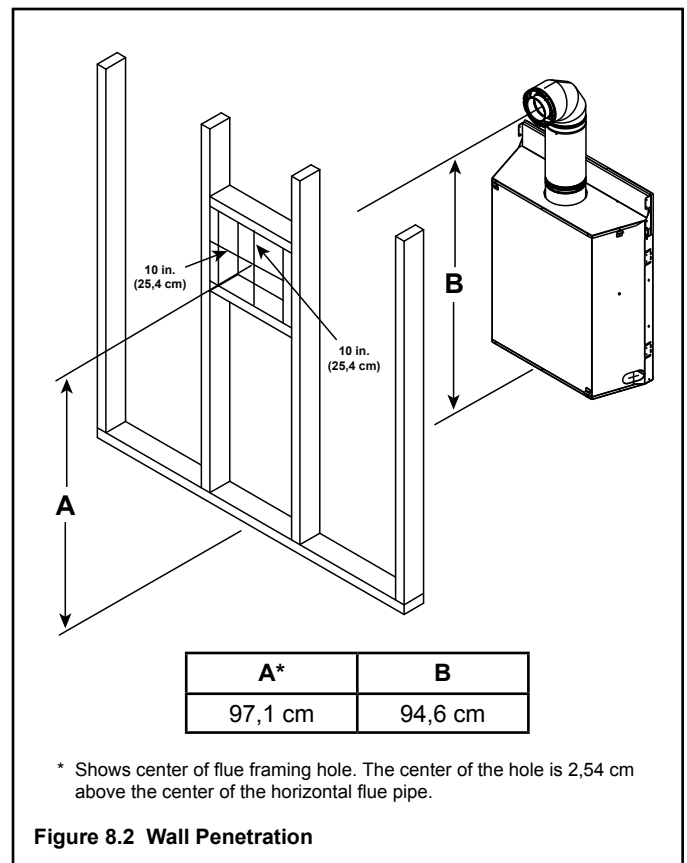

C. Install the Ceiling Firestop

A ceiling firestop **MUST** be used between floors and attics.

- **SLP pipe only** - Frame opening 22,9 cm x 22,9 cm whenever the vent penetrates a ceiling/floor (see Figure 8.3).
- Frame the area with the same sized lumber as used in ceiling/floor joist.
- The ceiling firestop may be installed above or below the ceiling joists when installed with a attic insulation shield. It must be under joists between floors that are not insulated. Refer to Figure 8.4.
- Secure with three fasteners on each side.

WARNING! Risk of Fire! DO NOT pack insulation around the vent. Insulation must be kept back from the pipe to prevent overheating.

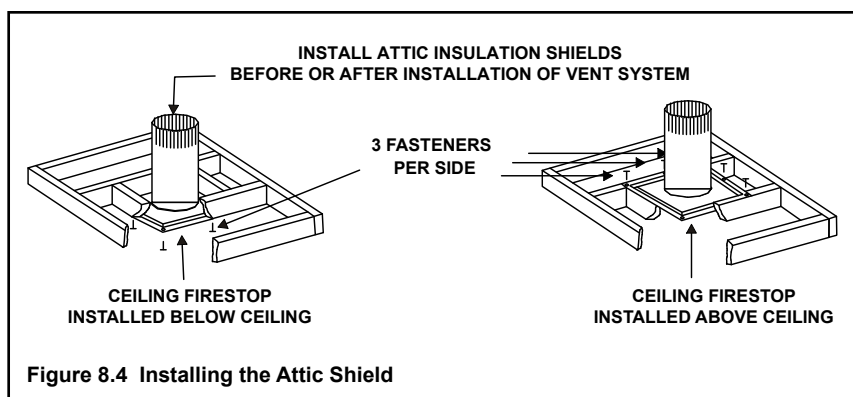
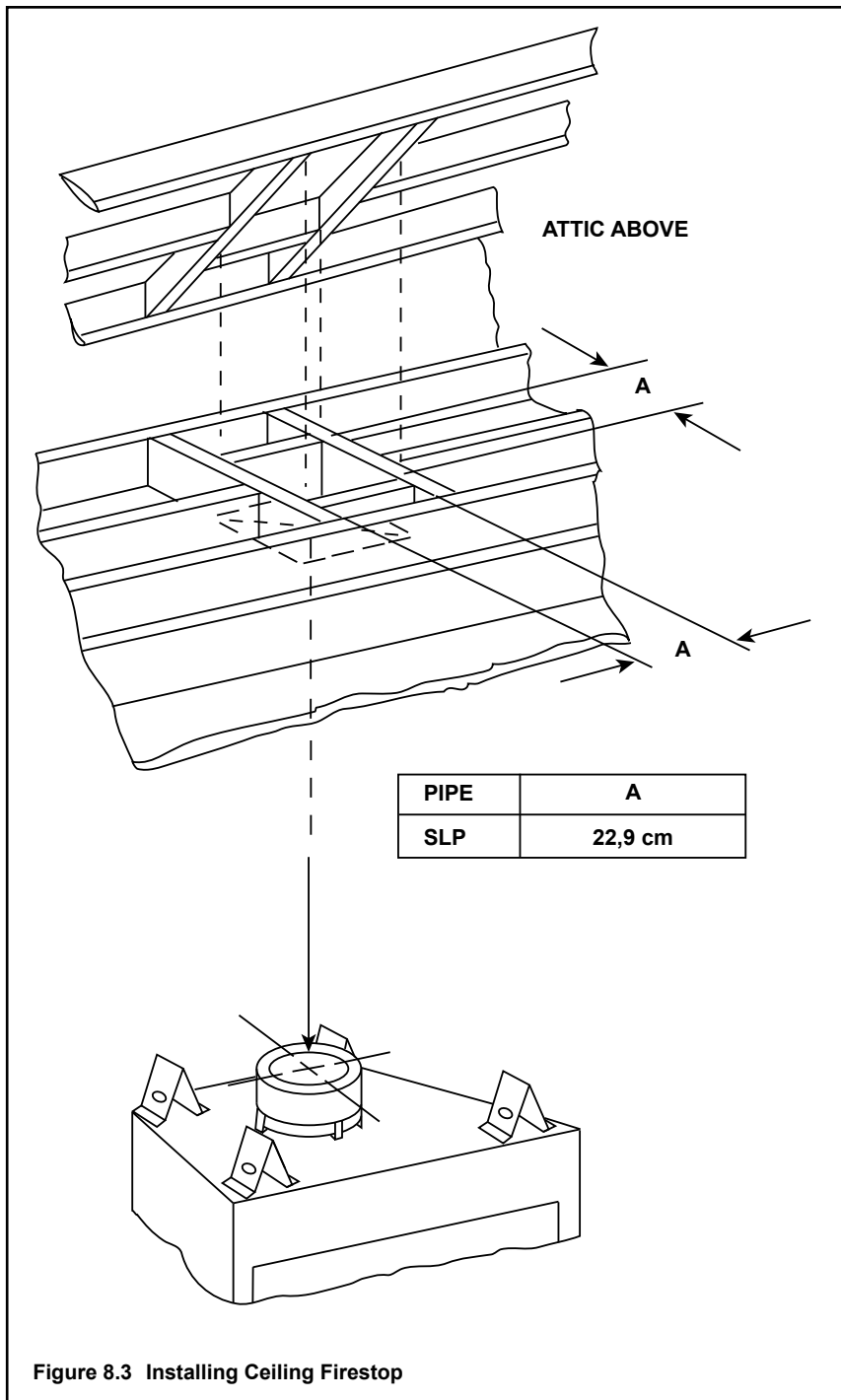

D. Install Attic Insulation Shield

WARNING! Fire Risk. DO NOT allow loose materials or insulation to touch vent. Hearth & Home Technologies requires the use of an attic shield.

An attic shield constructed of 26 gauge minimum metal that extends at least 2 in. (5,1 cm) above insulation is required.

Attic shields must meet specified clearance and be secured in place.

Flat Ceiling Installation

- Remove one shield from box.

NOTICE: Cut previously installed batt insulation to make room for the attic insulation shield.

- Wrap shield around pipe if pipe is already installed in area to be insulated.
- Match the three holes in each side and fasten with three screws to form a tube.
- Bend three tabs on the bottom of the shield outward to allow attachment to the ceiling firestop.
- Bend the remaining bottom tabs inward 90° to maintain the air space between the pipe and the shield. Set the shield on the ceiling firestop and attach to the firestop.
- Bend all tabs inward 90° around the top of the shield. These tabs must be used to prevent blown insulation from getting between the shield and vent pipe, and to maintain air space clearance.

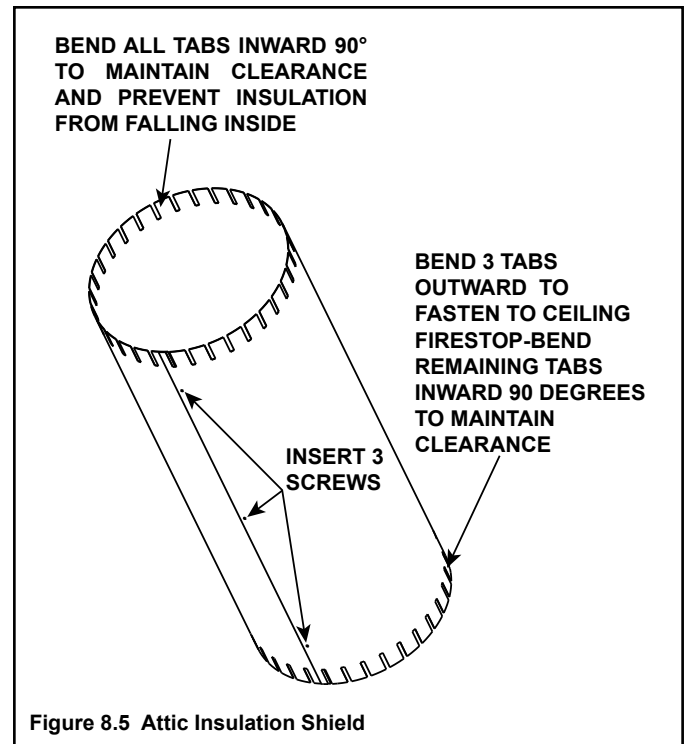

Vaulted Ceiling Installation

- Remove one shield from box.

NOTICE: Cut previously installed batt insulation to make room for the attic insulation shield.

- Cut the attic insulation shield (if application is for vaulted ceiling) to fit your ceiling pitch. Snip cut edge to recreate 1 in. bend tabs all the way around the bottom.
- Wrap shield around pipe if pipe is already installed in area to be insulated.
- Match the three holes in each side and fasten with three screws to form a tube.
- Bend three tabs on the bottom of the shield outward to allow attachment to the ceiling firestop.
- Bend the remaining bottom tabs inward 90° to maintain the air space between the pipe and the shield. Set the shield on the ceiling firestop and attach to the firestop.
- Bend all tabs inward 90° around the top of the shield. These tabs must be used to prevent blown insulation from getting between the shield and vent pipe, and to maintain air space clearance.

9 Appliance Preparation

A. Top Vent

CAUTION! Risk of Cuts, Abrasions or Flying Debris. Wear protective gloves and safety glasses during installation. Sheet metal edges are sharp.

NOTICE: Once appliance is set up for top or rear venting, it CANNOT be changed at a later time.



Figure 9.1

An elbow heat shield is attached to the SOHO-CEB. **Do not remove this heat shield.**



Figure 9.2

If venting with a 90 degree elbow directly off of the top of the unit, the heat shield should be placed as shown. Rotate the heat shield up to the vertical position and fold the tab down to contact the elbow. Make sure the rope ring, found in the manual bag, is in place around the elbow before attaching more pipe.

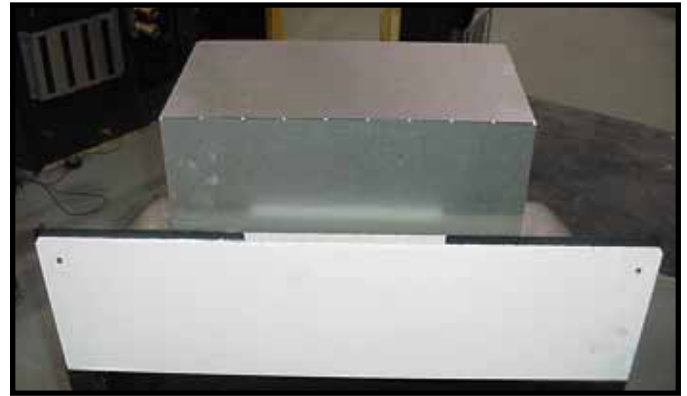

Figure 9.3

This is a view from the front of the unit when the elbow heat shield is properly in place.



Figure 9.4

If venting vertically or using vertical pipe before the elbow, rotate the elbow heat shield to a vertical position and fold the heat shield in half as shown. Make sure the rope ring, found in the manual bag, is in place around the first section of vent pipe.



Figure 9.5

This is a view from the front of the unit when not using an 90 degree elbow directly off the top of the unit.

B. Installation of Non-combustible Facing Material

The non-combustible assembly is located on the left side of appliance.

CAUTION! Handle with care. Non-combustible material may be damaged if dropped.

- Remove and save two screws from upper bracket.
- Remove non-combustible pieces.
- Remove and save two screws from lower bracket.
- Discard brackets.
- Replace screws in holes where brackets were attached to appliance.
- Attach non-combustible panel to appliance and framing with supplied screws. See Figures 9.6, 9.7 and 9.8.

CAUTION! Fire Risk. Follow these instructions exactly. Facing materials must be installed properly to prevent fire. No materials may be substituted without authorization by Hearth & Home Technologies.

- Use regular sheetrock screws in non-shaded areas.
- Use a wet or dry towel or soft brush to remove dust or dirt from facing material.
- Apply a non-combustible adhesive to attach tile, stone or other non-combustible finishing materials per manufacturer's instructions.

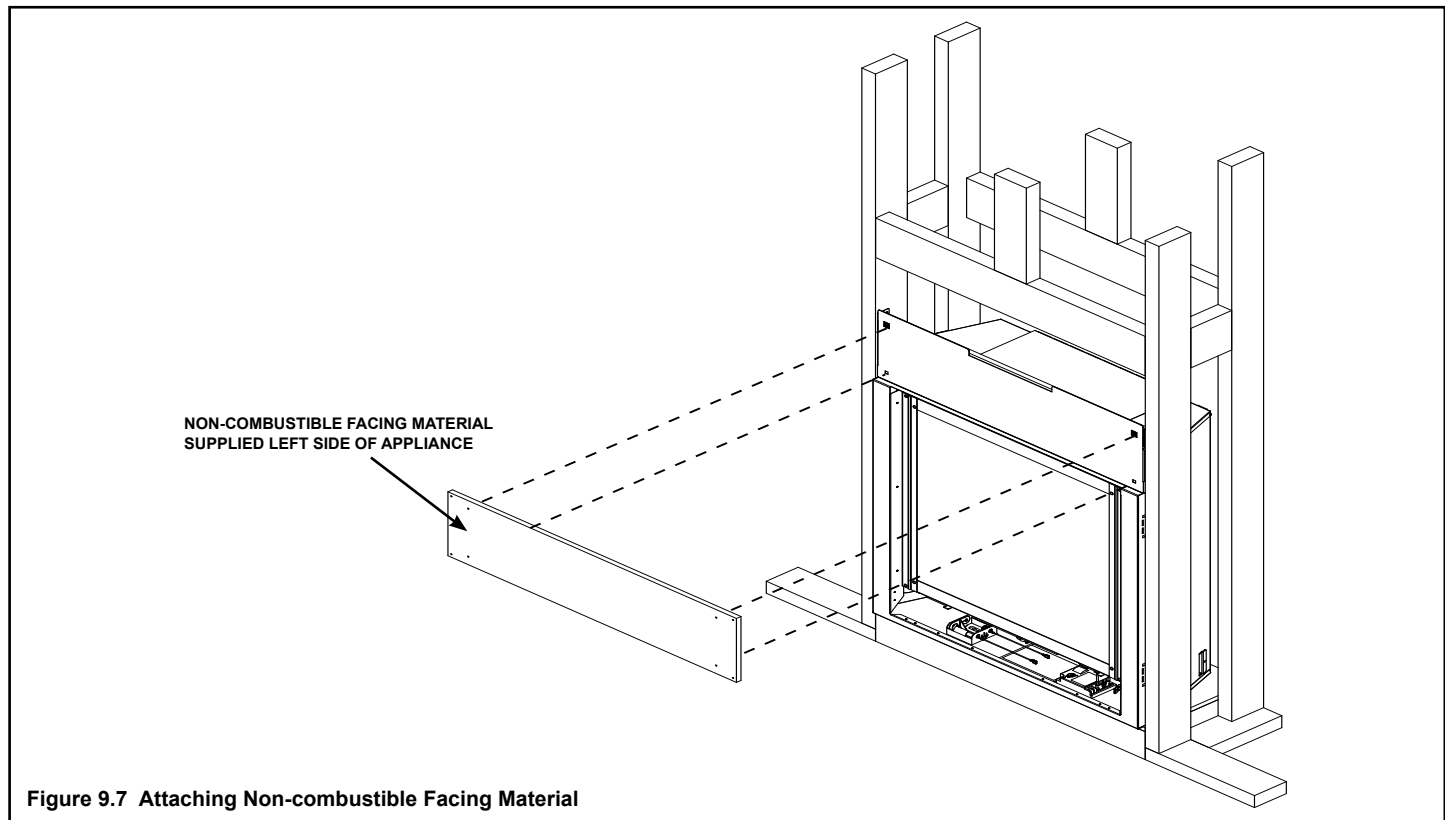
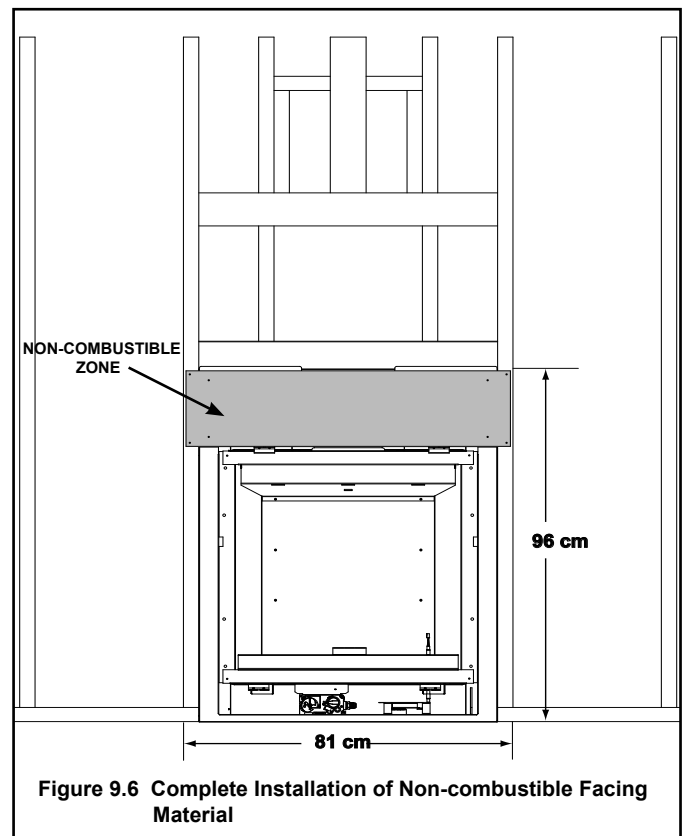

C. Securing and Leveling the Appliance

WARNING! Risk of Fire! Prevent contact with:

- Sagging or loose insulation
- Insulation backing or plastic
- Framing and other combustible materials

Block openings into the chase to prevent entry of blown-in insulation. Make sure insulation and other materials are secured.

DO NOT notch the framing around the appliance standoffs.

Failure to maintain air space clearance may cause overheating and fire.

The diagram shows how to properly position and secure the appliance (see Figure 9.8). Nailing tabs are provided to secure the appliance to the framing members.

- Bend out nailing tabs on each side.
- Place the appliance into position.
- Keep nailing tabs flush with the framing.
- Level the appliance from side to side and front to back.
- Shim the appliance as necessary. It is acceptable to use wood shims underneath the appliance.
- Secure the appliance to the framing by using nails or screws through the nailing tabs and two holes in each end of outer non-combustible panel.
- Secure the appliance to the floor by inserting two screws through the pilot holes at the bottom of the appliance.

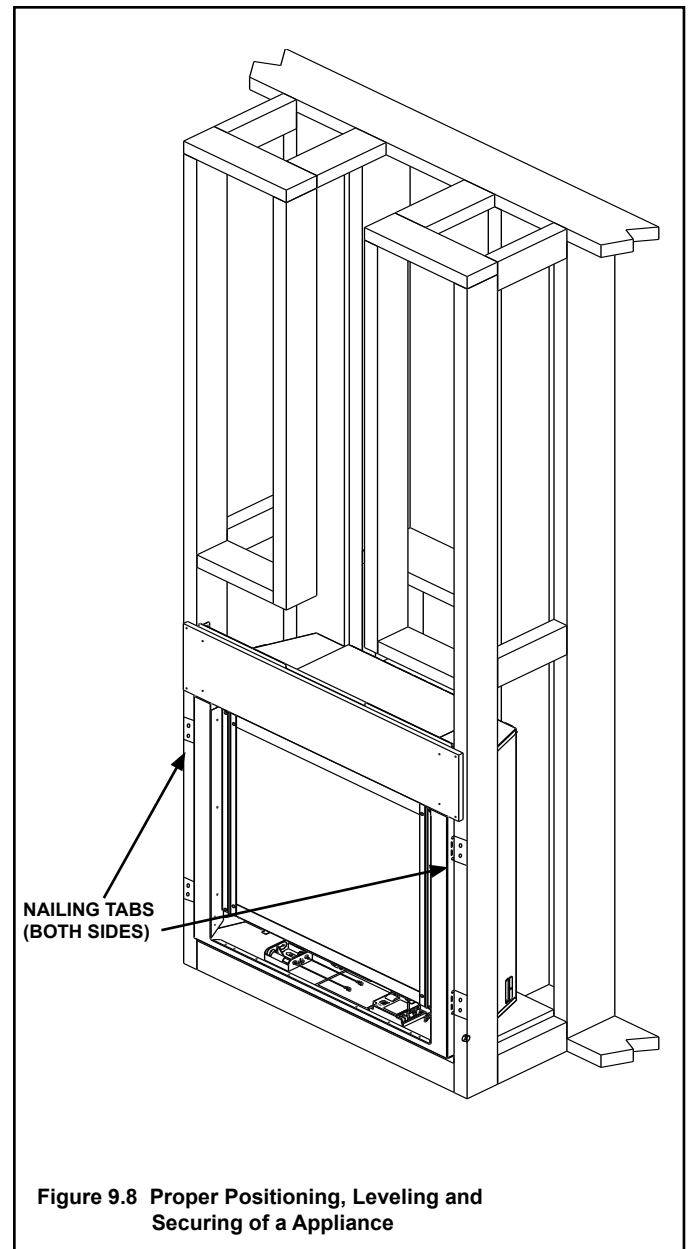

Figure 9.8 Proper Positioning, Leveling and Securing of a Appliance

D. Covers Removal For Servicing

Control Compartment Access Door

- Lift the lower door up and out to access the gas controls.

Trim Door and Glass Door

- Lift the front trim door up and out away from the appliance side surrounds. Replace the door when servicing is complete.
- Noting carefully how the brackets fit on the glass, release the two spring latches at the top and two at the bottom of the glass door. Carefully lift the glass up and out away from the appliance. See Figure 9.9.

Fixed Glass Assembly

WARNING! Risk of Asphyxiation! Handle fixed glass assembly with care. Inspect the gasket to ensure it is undamaged and inspect the glass for cracks, chips or scratches.

- **DO NOT** strike, slam or scratch glass.
- **DO NOT** operate fireplace with glass removed, cracked, broken or scratched.
- Replace as a complete assembly.

Removing Fixed Glass Assembly

- Pull the four glass assembly latches out of the groove on the glass frame. Remove glass door from the appliance (see Figure 9.9).

Replacing Fixed Glass Assembly

- Replace the glass door on the appliance. Pull out and latch the four glass assembly latches into the groove on the glass frame.

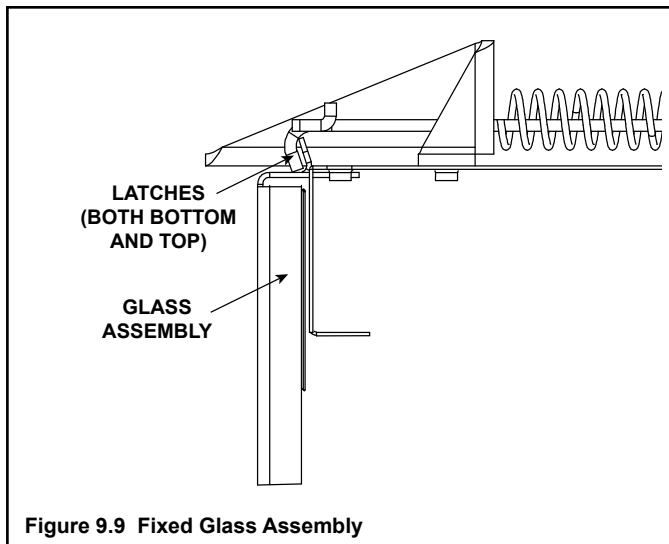

Figure 9.9 Fixed Glass Assembly

E. Components Removal For Service

- Release the screws at the base of the log grate and carefully lift up and remove the logs and log grate.
- Remove the base pan.
- Unscrew the brackets at both ends of the burner and the top two screws locating the pilot bracket (see Figure 9.10). Slide the burner away from the burner orifice.

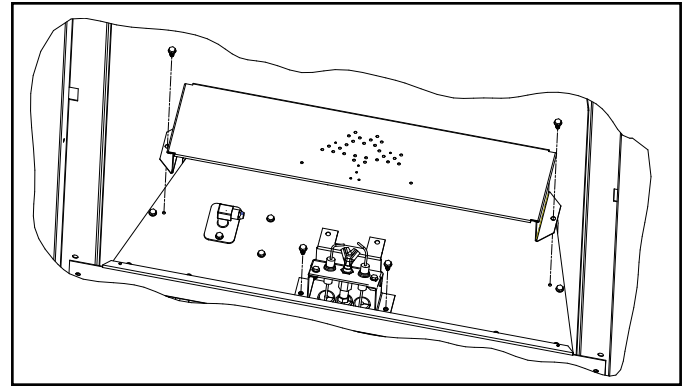

Figure 9.10

NOTICE: All screws which were removed must be replaced.

Pilot Assembly/Ignition System

- Remove the log set, log grate and burner assembly.
- Disconnect the gas supply tube from the outlet side of valve.
- Disconnect the orange ignitor wire (I) and white sensor wire (S) from module.
- Unscrew the pilot assembly bracket and remove, the pilot assembly along with silicone sealant grommet.

F. Parts Replacement

Fan

- Unplug the fan from the AUX300CE and slide the fan out the front of the lower controls compartment.
- Fan can be operated at 3 speed levels using RC300CE remote and AUX300CE. Refer to RC300CE section.
- The fan will automatically turn on after 3 minutes and will stop 12 minutes after unit has been turned off.

Glass Panel

- To replace the glass door, place the bottom edge into the lower holders, push glass against unit and secure the two spring latches at the top and bottom.

G. Adjustments And Replacement Parts

Adjustments and replacement parts for this appliance should only be done by a qualified service person. A wiring diagram for the appliance is shown in Section 12. A service parts list is shown in Section 16 of this manual.

H. Install Trim and/or Surround

- Install optional trim kits and/or surrounds using the instructions included with the accessory.
- Use non-combustible materials to cover the gap between the sheet rock and the appliance (when applicable to the model).

I. Air Shutter Setting

	Natural Gas	Propane	Butane
SOHO-N-CEB	7/16 in (1,1 cm)	N/A	N/A
SOHO-P-CEB	N/A	1/2 in. (1,3 cm)	N/A
SOHO-B-CEB	N/A	N/A	Full open

10 Installing Vent Pipe (SLP Pipe)

A. Assemble Vent Sections

To attach the first vent component to the starting collars of the appliance:

- Lock the vent components into place by sliding the pipe section onto the collar.
- Align the seam of the pipe and seam of collar to allow engagement. Rotate the vent component to lock into place. Use this procedure for all vent components. See Figure 10.1.
- Slide the gasket over the first vent section and place it flush to the appliance. This will prevent cold air infiltration. High temperature caulk (150 °C minimum continuous exposure rating) may be used to hold the part in place.
- Continue adding vent components, locking each succeeding component into place.
- Ensure that each succeeding vent component is securely fitted and locked into the preceding component.

Commercial, Multi-family (Multi-level exceeding two stories), or High-Rise Applications

For Installation into a commercial, multi-family (multi-level exceeding two stories) or high-rise applications: All outer pipe joints must be sealed with high temperature (150 °C minimum continuous exposure rating) silicone, including the slip section that connects directly to the horizontal termination cap.

- Apply a bead of silicone sealant inside the female outer pipe joint prior to joining sections. See Figure 10.2
- Only outer pipes need to be sealed. All unit collar, pipe, slip section, elbow and cap outer flues shall be sealed in this manner, unless otherwise stated.

WARNING! Risk of Fire or Explosion! DO NOT break silicone seals on slip sections. Use care when removing termination cap from slip pipe. If slip section seals are broken during removal of the termination cap, vent may leak.

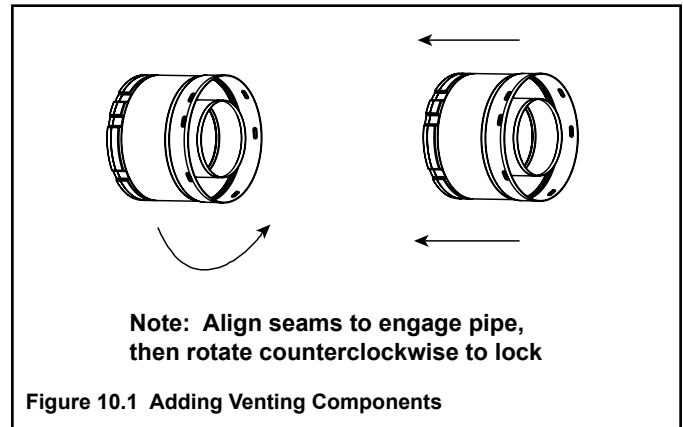

Figure 10.2 High Temperature Silicone Sealant

B. Assemble Slip Sections

- Slide the inner flue of the slip section into the inner flue of the pipe section and the outer flue of the slip section over the outer flue of the pipe section. See Figure 10.3.
- Slide together to the desired length.

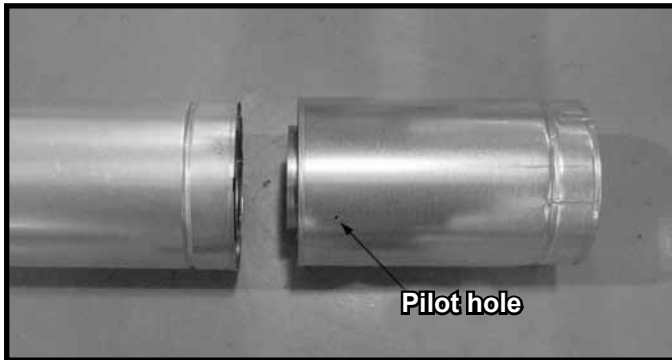

Figure 10.3 Slip Section Pilot Holes

- Maintain a 3,8 cm overlap between the slip section and the pipe section.
- Secure the pipe and slip section with two screws no longer than 1,3 cm, using the pilot holes in the slip section. See Figure 10.4.

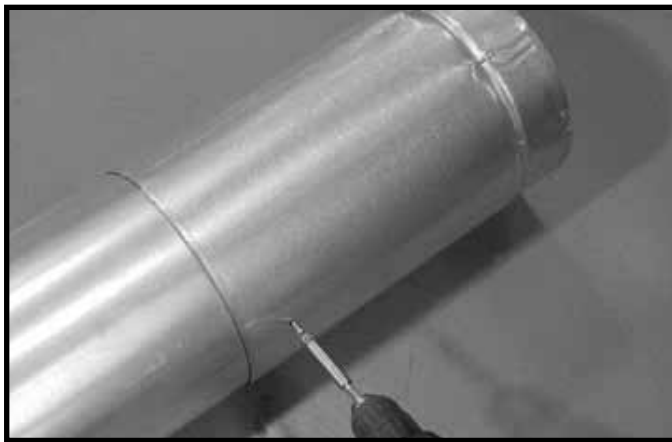

Figure 10.4 Screws into Slip Section

- Continue adding pipe as necessary following instructions in “Assembling Pipe Sections.”

NOTICE: If slip section is too long, the inner and outer flues of the slip section can be cut to the desired length.

NOTICE: When installing a vent system with an HRC termination cap, all pipe system joints shall be sealed using a high temperature (150 °C minimum continuous exposure rating) silicone sealant.

- Apply a bead of silicone sealant inside the female outer pipe joint prior to joining sections.
- Only outer pipes are sealed, sealing the inner flue is not required.
- All unit collar, pipe, slip section, elbow and cap outer flues shall be sealed.

C. Secure the Vent Sections

- Vertical runs of SLP pipe must be supported every 2,44 m.
- Horizontal sections must be supported every 1,52 m.
- Vent supports or plumbers strap (spaced 120° apart) may be used to support vent sections. See Figures 10.5 and 10.6.
- Wall shield firestops may be used to provide horizontal support vent sections.
- Ceiling firestops have tabs that may be used to provide vertical support.

WARNING! Risk of Fire, Explosion or Asphyxiation! Improper support may allow vent to sag and separate. Use vent run supports and connect vent sections per installation instructions. **DO NOT** allow vent to sag below connection point to appliance.

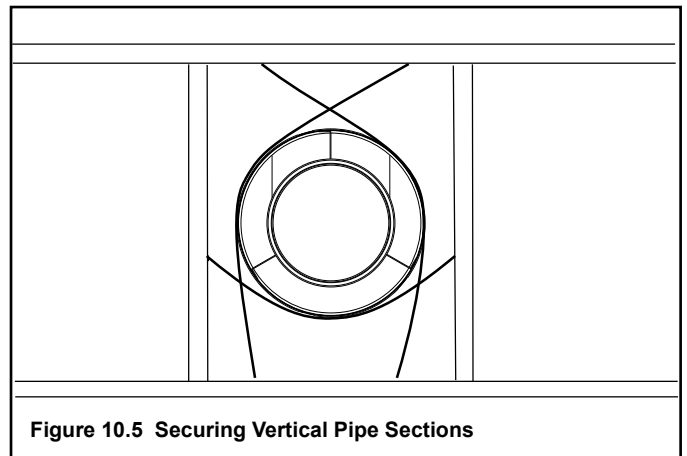

Figure 10.5 Securing Vertical Pipe Sections

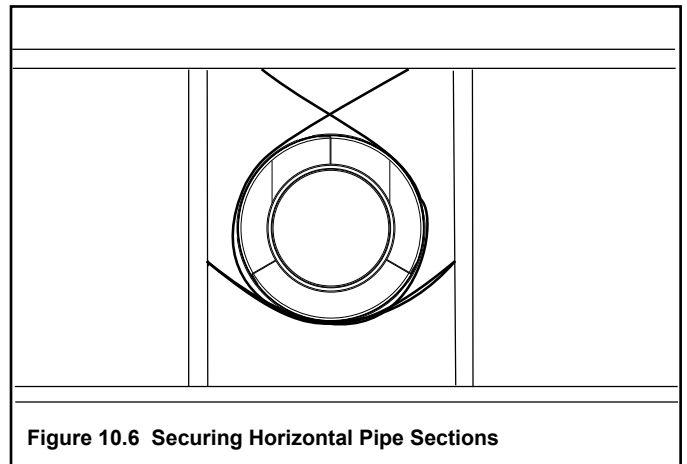

Figure 10.6 Securing Horizontal Pipe Sections

D. Disassemble Vent Sections

- Rotate either section (see Figure 10.7) so the seams on both pipe sections are aligned as shown in Figure 10.8.
- Pull carefully to separate the pieces of pipe.

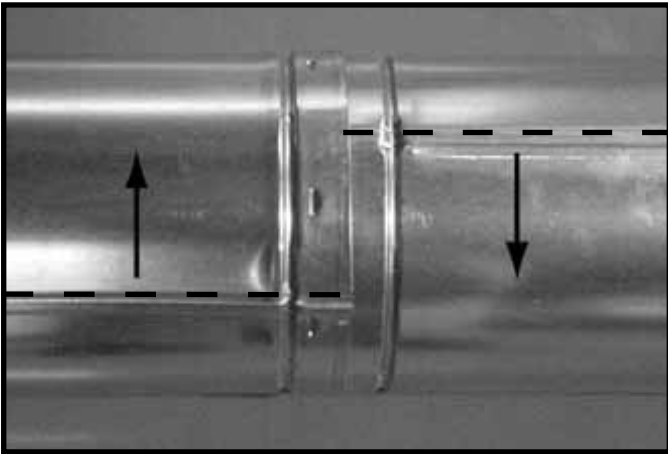

Figure 10.7 Rotate Seams for Disassembly

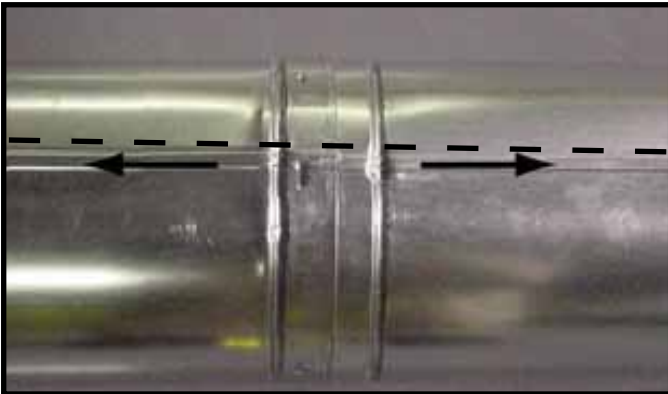

Figure 10.8 Align and Disassemble Vent Sections

E. Install Support Brackets

For Horizontal Runs - The flue system must be supported every five (5) feet (1,52 m) of horizontal run by a horizontal pipe support. To install support brackets for horizontal runs:

- Place the pipe supports around the flue pipe.
- Nail the pipe supports to the framing members.

For Vertical Runs - The flue system must be supported every eight feet (2,44 m) above the fireplace flue outlet by wall brackets. To install support brackets for vertical runs:

- Attach wall brackets to the flue pipe and secure the wall bracket to the framing members with nails or screws.

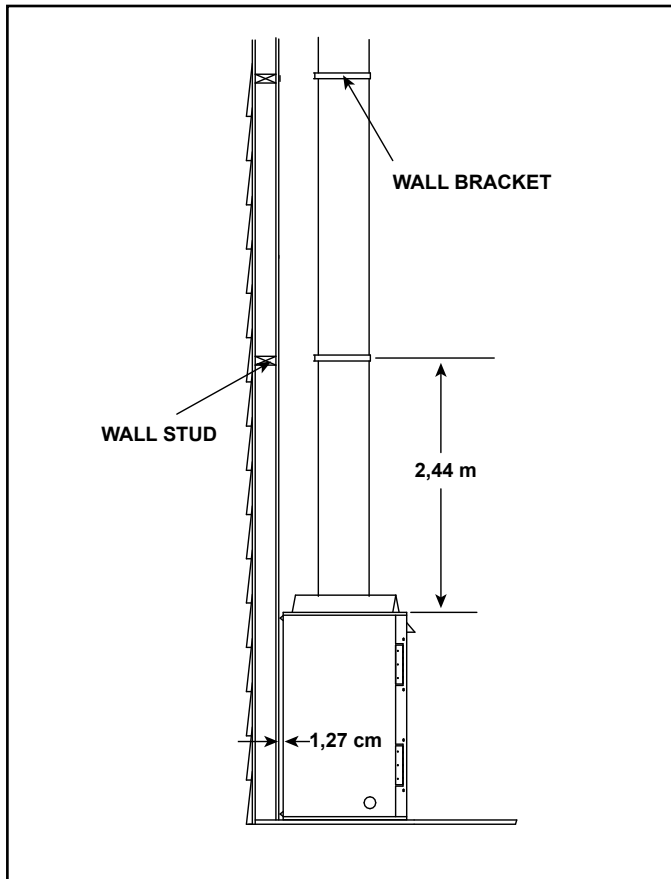

Figure 10.9 Installing Support Brackets

F. Install Firestops

For Horizontal Runs - Firestops are **REQUIRED** on both sides of a combustible wall through which the flue passes.

To install firestops (heat shield) for horizontal runs that pass through either interior or exterior walls:

- Cut a 25,4 cm X 25,4 cm hole through the wall.
- Position the firestops on both sides of the hole previously cut and secure the firestops with nails or screws.
- The pipe opening of the firestops **MUST BE** placed towards the bottom of the firestop.
- Continue the flue run through the firestop.

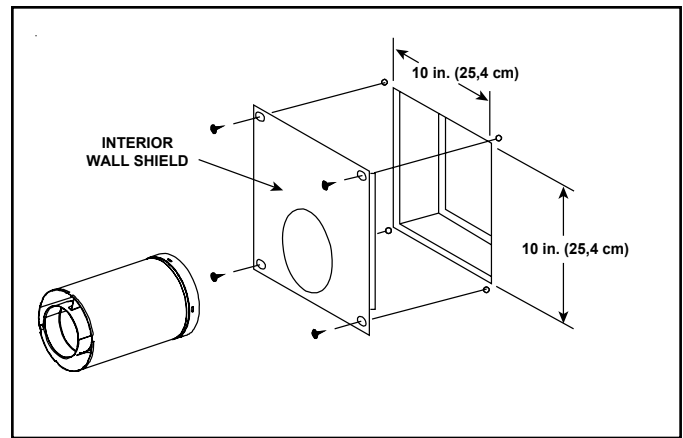

Figure 10.10 Flue Pipe & Firestop

For Vertical Runs - One firestop is **REQUIRED** at the hole in each ceiling through which the flue passes.

To install firestops for vertical runs that pass through ceilings:

- Position a plumb bob directly over the center of the vertical flue component.
- Mark the ceiling to establish the centerpoint of the flue.
- Drill a hole or drive a nail through this center point.
- Check the floor above for any obstructions, such as wiring or plumbing runs.
- Reposition the fireplace and flue system, if necessary, to accommodate the ceiling joists and/or obstructions.
- Cut a 22,9 cm x 22,9 cm hole through the ceiling when using SLP pipe. Use the firestop pipe opening as a guide.
- Frame the hole with framing lumber the same size as the ceiling joists.

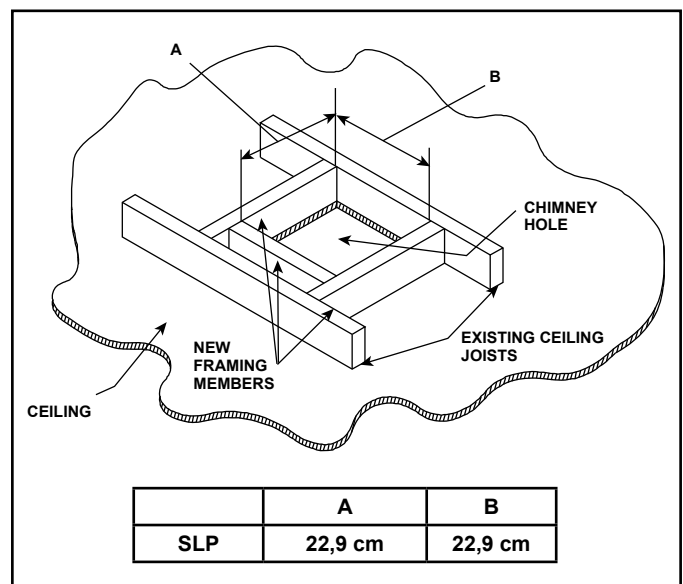

Figure 10.11 Hole and New Framing Members

If the area above the ceiling is **NOT** an attic, position and secure the ceiling firestop on the ceiling side of the previously cut and framed hole.

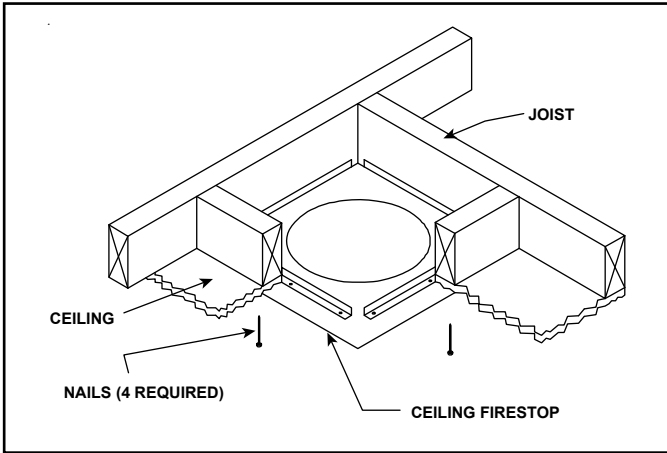

Figure 10.12 Ceiling Firestop (Ceiling Side)

If the area above the ceiling **IS** an attic, position and secure the firestop on top of the previously framed hole.

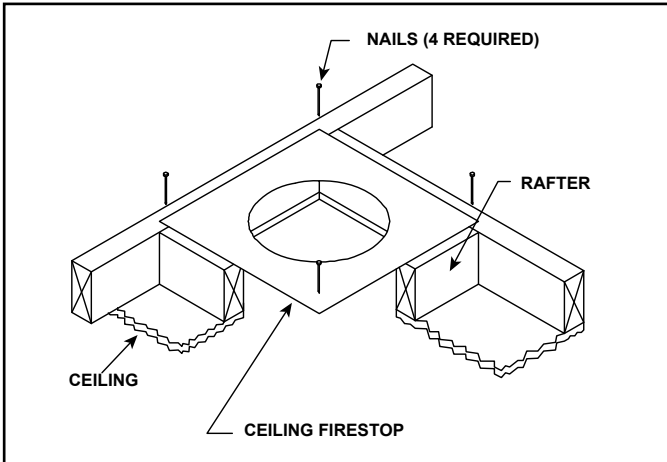

Figure 10.13 Attic Firestop

G. Flue Termination

For Horizontal Terminations using the SLP-TRAP

To attach and secure the termination to the last section of horizontal flue:

- The rear flue heat shield **MUST** be placed one inch (2,54 cm) above the top of the flue between the wall shield and the base of the termination cap.
- One section of the heat shield is attached to the wall shield. The other is attached to the termination cap in the same manner (see Figure 10.14).
- The heat shield sections will overlap to match the wall thickness (depth).
- If the wall thickness does not allow the required 1-1/2 in. (3,8 cm) heat shield overlap, an extended heat shield must be used. The extended heat shield will need to be cut to the thickness of the wall and be attached to the wall shield.
- The small leg in the shield rests on top of the flue to properly space it from the pipe section (see Figure 10.14).

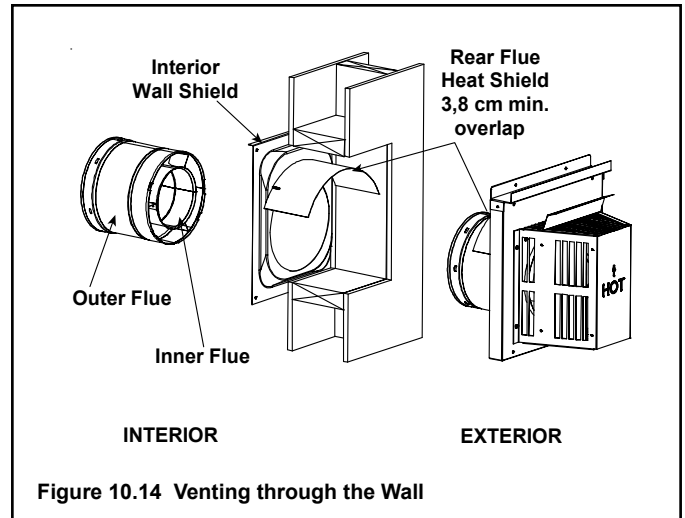

Figure 10.14 Venting through the Wall

- The termination kit should pass through the wall firestops from the exterior of the building.
- Adjust the termination cap to its final exterior position on the building and interlock the flue sections.

WARNING! Risk of Fire! the termination cap must be positioned so that the arrow is pointing up.

- Use a high-temperature sealant gasket to seal between the pipe and exterior firestop.

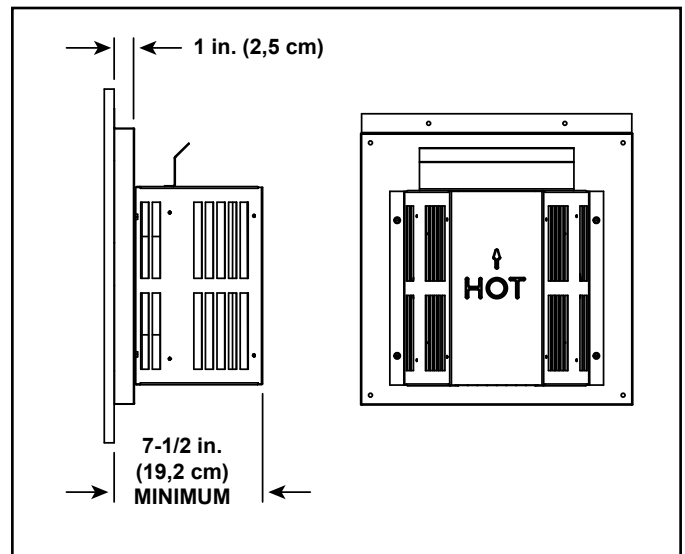

Figure 10.15 Termination Cap

Cap Specification Chart (depth without using additional pipe sections)

SOHO-CEB	SLP-TRAP2 Rear Vent Depth
	5-1/2 in. (13,9 cm) to 9-1/2 in. (24,1 cm)

SLP-TRAP2 can adjust 4 in. 10,2 cm (5-3/8 to 9-3/8) (13,7 cm to 23,8 cm)

H. Heat Shield Requirements for Horizontal Termination

WARNING! Risk of Fire! To prevent overheating and fire, heat shields must extend through the entire wall thickness.

- **DO NOT** remove the heat shields attached to the wall shield firestop and the horizontal termination cap (shown in Figure 10.14).
- Heat shields must overlap 1-1/2 in. (3,8 cm) minimum.

There are two sections of the heat shield. One section is factory-attached to the wall shield firestop. The other section is factory-attached to the cap. See Figure 10.14.

If the wall thickness does not allow the required 1-1/2 in. (3,8 cm) heat shield overlap when installed, an extended heat shield must be used.

- If the wall thickness is less than or 4-3/8 in. (11,1 cm), the heat shields on the cap and wall shield firestop must be trimmed. A minimum 1-1/2 in. (3,8 cm) overlap **MUST** be maintained.
- Use an extended heat shield if the finished wall thickness is greater than 7-1/4 in. (18,4 cm).
- The extended heat shield may need to be cut to length maintaining sufficient length for a 1-1/2 in. (3,8 cm) overlap between heat shields.
- Attach the extended heat shield to either of the existing heat shields using the screws supplied with the extended heat shield. Refer to vent components diagrams in the back of this manual.
- Rest the small leg on the extended heat shield on top of the pipe section to properly space it from the pipe section.

Important Notice: Heat shields may not be field constructed.

I. Install Metal Roof Flashing

- See minimum vent heights for various pitched roofs (Figure 10.16) to determine the length of pipe to extend through the roof.
- Slide the roof flashing over the pipe sections extending through the roof as shown in Figure 10.17.

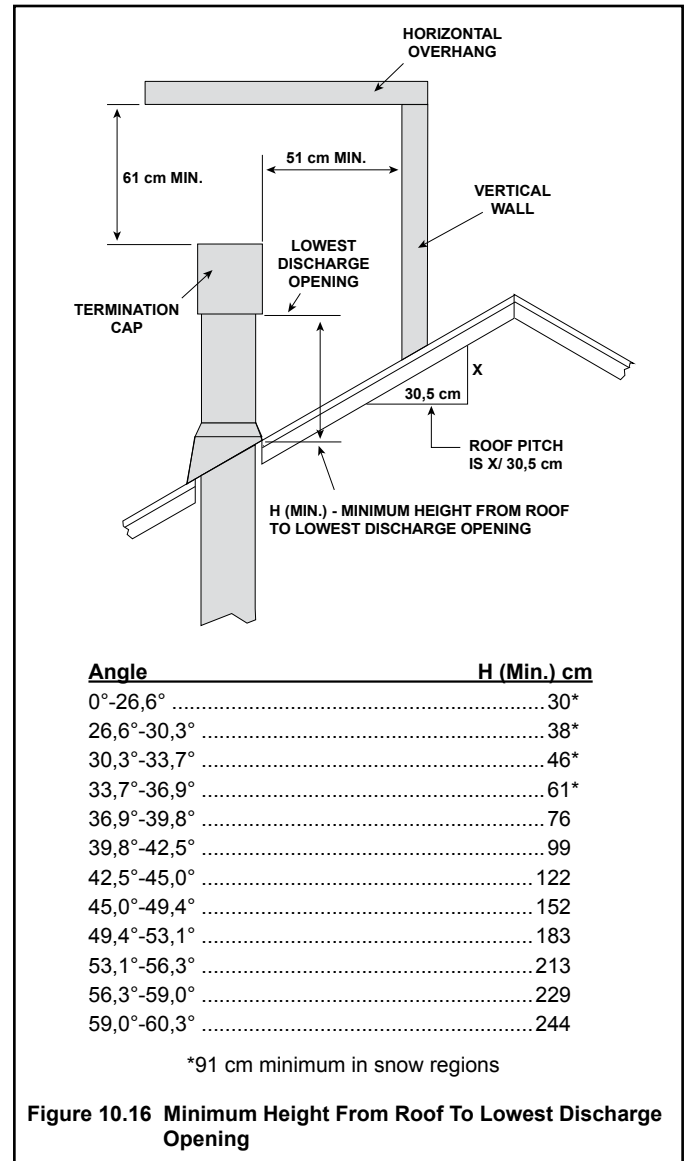

NOTICE: Failure to properly caulk the roof flashing and pipe seams may permit entry of water entry.

- Caulk the gap between the roof flashing and the outside diameter of the pipe.
- Caulk the perimeter of the flashing where it contacts the roof surface. See Figure 10.17.
- Caulk the overlap seam of any exposed pipe sections that are located above the roof line.

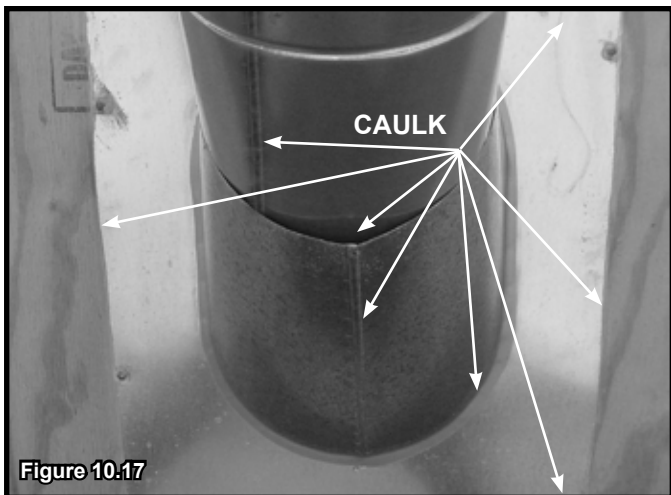

Figure 10.17

J. Assemble and Install Storm Collar

CAUTION! Risk of Cuts, Abrasions or Flying Debris. Wear protective gloves and safety glasses during installation. Sheet metal edges are sharp.

- Connect both halves of the storm collar with two screws (see Figure 10.18).
- Wrap the storm collar around the exposed pipe section closest to the roof and align brackets. Insert a bolt (provided) through the brackets and tighten the nut to complete the storm collar assembly. Make sure the collar is tight against the pipe section.
- Slide the assembled storm collar down the pipe section until it rests on the roof flashing (see Figure 10.19).
- Caulk around the top of the storm collar (see Figure 10.20).

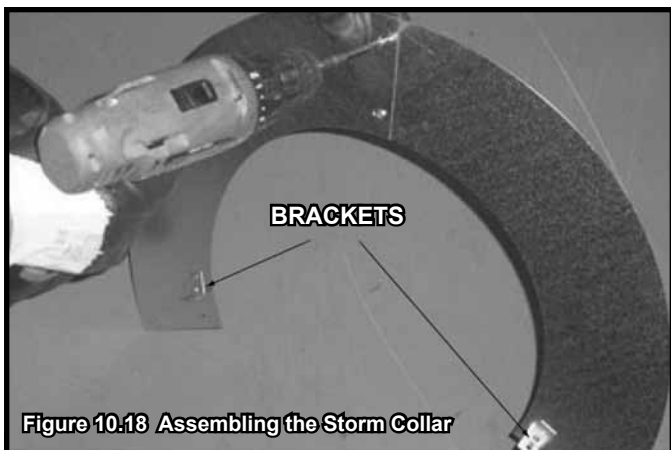

Figure 10.18 Assembling the Storm Collar



Figure 10.19 Assembling the Storm Collar Around the Pipe

K. Install Vertical Termination Cap

- Locate and mark the flue center point on the underside of the roof, and drive a nail through the center point.
- Make the outline of the roof hole around the center point nail.
- The size of the roof hole framing dimensions depend on the pitch of the roof. There **MUST BE** a 1 inch (2,5 cm) clearance from the vertical flue pipe to combustible materials.
- Mark the roof hole accordingly.
- Cover the opening of the installed flue pipes.
- Cut and frame the roof hole.
- Use framing lumber the same size as the roof rafters and install the frame securely. Flashing anchored to the frame must withstand heavy winds.
- Continue to install concentric flue sections up through the roof hole and up past the roof line until you reach the appropriate distance above the roof.
- Attach the vertical termination cap by sliding the inner collar of the cap into the inner flue of the pipe section while placing the outer collar of the cap over the outer flue of the pipe section.
- Secure the cap by driving three self-tapping screws (supplied) through the pilot holes in the outer collar of the cap into the outer flue of the pipe (see Figure 10.20).



Figure 10.20

11 Gas Information

A. Gas Pressure Requirements

Pressure requirements for SOHO-CEB fireplaces are shown in below.

Two taps are provided on the right hand side of the gas control for a test gauge connection to measure the inlet and outlet pressures.

The fireplace and its individual shut-off valve must be disconnected from the gas supply piping system during any pressure testing of the system at test pressures in excess of 60 mbar.

If the fireplace must be isolated from the gas supply piping system by closing an individual shut-off valve, it must be of the handle-less type.

⚠ WARNING

Fire Risk
Explosion Risk
High pressure will damage valve.

- Disconnect gas supply piping BEFORE pressure testing gas line at test pressures above 60 mbar.
- Close the manual shutoff valve BEFORE pressure testing gas line at test pressures equal to or less than 60 mbar.

→ There is a vent hole on the regulator to equalize the pressure on the diaphragm. It also a small amount of air in the top side of diaphragm to keep the pressure readings more consistent. This **not** for gas leakage.

B. Gas Connection

Note: Have the gas supply line installed in accordance with local building codes by a qualified installer approved and/or licensed as required by the locality.

Note: Before the first firing of the appliance, the gas supply line should be purged of any trapped air.

Note: Consult local building regulations to properly size the gas supply line leading to the (Rp 1/2 in.) hook-up at the unit.

Incoming gas line should be piped into the valve compartment and connected to the ISO 7-Rp 1/2 (BSP Rp 1/2) threaded gas inlet connection on the manual shutoff valve.

Leak test all gas line points and the gas control valve prior to and after starting the gas appliance.

⚠ WARNING

CHECK FOR GAS LEAKS
Explosion Risk
Fire Risk
Asphyxiation Risk

- Check all fittings and connections.
- Do not use open flame.
- After the gas line installation is complete, all connections must be tightened and checked for leaks with a commercially-available, non-corrosive leak check solution. Be sure to rinse off all leak check solution following testing.

Fittings and connections may have loosened during shipping and handling.

	Natural Gas (G20)	Natural Gas (G25)	Butane (G30)	Propane (G31)
CAT	I_{2H}, I_{2E}, I_{2E+}	I_{2E+}	$I_{3B/P}$	I_{3P}
Inlet Pressure	20 mbar	25 mbar	37 or 50 mbar	37 or 50 mbar
Burner Pressure	8,4 mbar	8,4 mbar	24 mbar	24 mbar
Gas Rate	Max. 0,405 m ³ /h	Max. 0,405 m ³ /h	Max. 0,111 m ³ /h	Max. 0,134 m ³ /h
Heat Input (Net)	4,0 kW	3,5 kW	3,6 kW	3,5 kW
Burner Injector	DMS 50 (1,78 mm)	DMS 50 (1,78 mm)	DMS 61 (1,07 mm)	DMS 58 (1 mm)
Pilot Injector	0,023	0,023	0,010	0,014

Columns highlighted in gray = The gas control valve supplied with this product is approved for a maximum inlet pressure of 37 mbar. For pressures over 37 mbar, an in line pressure regulator must be installed upstream from the gas control valve.

The gas is introduced to the appliance on the left hand side. See Figure 11.1.

After the gas pipe installation is complete, check carefully all gas connections for leaks with a commercially-available, noncorrosive leak check solution. Be sure to rinse off all leak check solution following testing. **DO NOT USE AN OPEN FLAME.**

NOTICE: the gas supply line should be purged of any trapped air prior to the first firing of the unit.

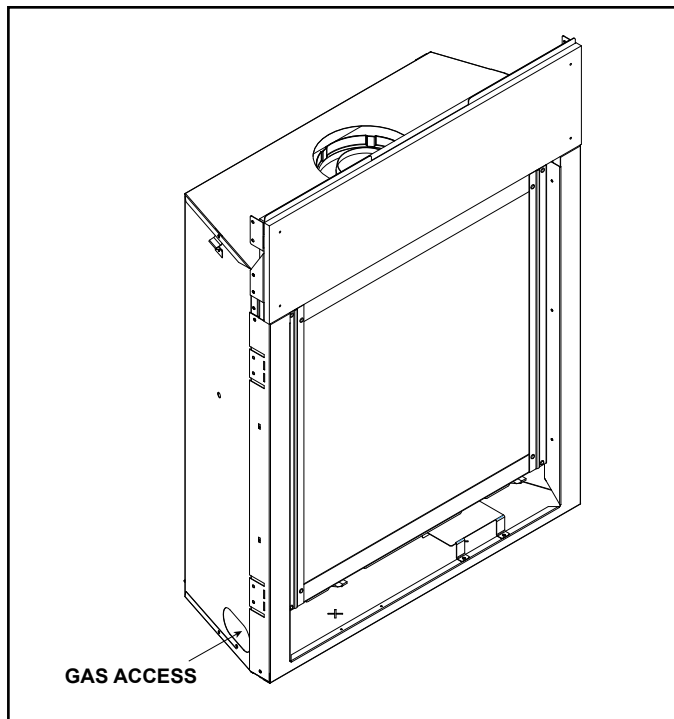

Figure 11.1

- Refer to Reference Section 16 for location of gas line access in appliance.
- Gas line may be run through knockout(s) provided.
- The gap between supply piping and gas access hole may be caulked with high temperature caulk (150 °C minimum continuous exposure rating) or stuffed with non-combustible, unfaced insulation to prevent cold air infiltration.
- Ensure that gas line does not come in contact with outer wrap of the appliance. Follow local codes. Reference BS EN 613:2001 Standard.
- Pipe incoming gas line into valve compartment.
- Connect incoming gas line to the connection on manual shutoff valve.

WARNING! Risk of Fire or Explosion! Support control when attaching pipe to prevent bending gas line.

- A small amount of air will be in the gas supply lines.

WARNING! Risk of Fire or Explosion! Gas build-up during line purge could ignite.

- Purge should be performed by qualified service technician.
- Ensure adequate ventilation.
- Ensure there are no ignition sources such as sparks or open flames.

Light the appliance. It will take a short time for air to purge from lines. When purging is complete the appliance will light and operate normally.

WARNING! Risk of Fire, Explosion or Asphyxiation! Check all fittings and connections with a non-corrosive commercially available leak-check solution. **DO NOT** use open flame. Fittings and connections could have loosened during shipping and handling.

WARNING! Risk of Fire! DO NOT change valve settings. This valve has been preset at the factory.

12 Electrical Information

A. Wiring Requirements

NOTICE: This appliance must be installed by a qualified electrician in accordance with the relevant national and local regulations.

- Wire the appliance junction box to 230 VAC. This is required for proper operation of the appliance.

WARNING! Risk of Shock or Explosion! DO NOT wire 230 VAC to the valve or to the appliance wall switch. Incorrect wiring will damage controls.

NOTICE: The mains supply to the appliance must have isolation of a minimum 3 mm contact separation in both poles.

WARNING! Risk of Injury! The gas supply shall be shut off prior to disconnecting the electrical power and removing batteries (if installed) before proceeding with any maintenance to the appliance.

B. IntelliFire Plus™ Ignition System Wiring

- Wire the appliance junction box to 230 VAC for proper operation of the appliance.

WARNING! Risk of Shock or Explosion! DO NOT wire IPI controlled appliance junction box to a switched circuit. Incorrect wiring will override IPI safety lockout.

- Refer to Figure 12.1, IntelliFire Plus™ Pilot Ignition (IPI) Wiring Diagram.
- This appliance is equipped with an IntelliFire Plus™ control valve which operates on a 6 volt system.

- An in-line isolation switch must be installed within 1 meter of the fireplace. This is required for servicing and/or resetting the control module in the event of a control module LOCK-OUT.

- Plug the 6 VAC power supply into the appliance junction box to supply power to the unit.

C. Optional Accessories Requirements

- This appliance may be used with a wall switch, wall mounted thermostat and/or a remote control.

Wiring for optional Hearth & Home Technologies approved accessories should be done now to avoid reconstruction. Follow instructions that come with those accessories.

Optional Remote Control Receiver Location

The control module and remote control receiver can be accessed through the air space below the firebox front and the lower access door.

The IPI control module and the remote control receiver are placed on the firebox bottom.

WARNING! Risk of Shock! Label all wires prior to disconnection when servicing controls. Wiring errors can cause improper and dangerous operation. Verify proper operation after servicing.

WARNING! Risk of Shock! Replace damaged wire with type 105° C rated wire. Wire must have high temperature insulation.

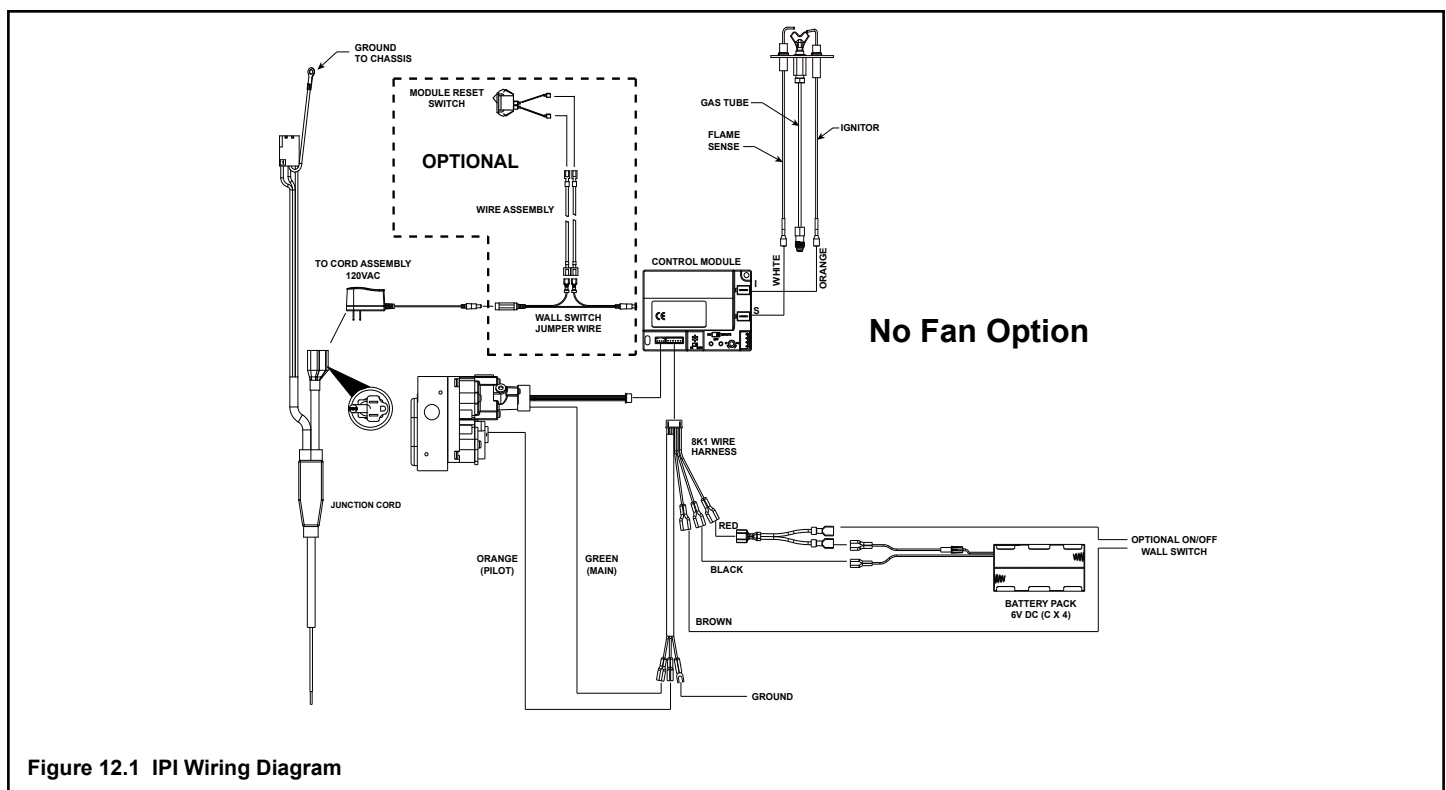

Figure 12.1 IPI Wiring Diagram

D. Control Module Operation

See Section 2.1 for Control Module Operation.

Hearth & Home Technologies disclaims any responsibility for, and the warranty will be voided by, the following actions:

- Installation and use of any damaged system component.
- Modification of the system component.
- Installation other than as instructed by Hearth & Home Technologies.
- Installation and/or use of any component part not approved by Hearth & Home Technologies.

Any such action may cause a fire hazard.

- Read, understand and follow these instructions for safe installation and operation.

Fireplace Specific Information

Standard fireplace features vary. Consult the installation manual for available options.

The optional **AUX300CE** receiver provides additional features: Fan control and two Aux functions.

The **REM300-HNG-CE** remote control system functions include: On/Off, Thermostat Mode, Timer Countdown, and Flame Adjustment (for fireplaces with variable flame).

Kit Contents

REM300-HNG-CE

- REM300-HNG-CE Transmitter
- AAA Batteries (3)
- Wall Holder
- Drywall Anchor (2)
- Screws (2)

Introduction

The RC300CE multifunctional remote control is designed to control pilot light, flame height, blower speed, and up to two 230 VAC auxiliary functions on your gas fireplace. The RC300CE is equipped with thermostat functions which can automatically control the temperature in the room in which it is installed. The control is only for use with the Hearth & Home Technologies IntelliFire Plus™ system (IPI). The AUX300CE module is rated for 230 VAC, 50-60 Hz, and is required for operation of this remote control device.

Installation Precautions

The installation of this remote control must be performed by a qualified service technician. This remote control is tested and safe when installed in accordance with this installation manual. Do not install any components that may be damaged.

Do not modify, disassemble, or substitute any of the components included with this kit. Installation of this unit must be done by a qualified service technician.

Placement of this remote control may affect performance. An assessment of the space should be done prior to installation for optimum performance.

Determine Location

Determine the location for the remote control. The selected location should be in the same space as the gas fireplace. Never place this unit in a separate room. The remote control must be placed within 30 feet (9,14 m) of the fireplace but should not be exposed to extreme heat.

The RC300CE is approved for interior installation and should not be used in exterior applications.

- Keep remote control out of reach of children.

FCC Requirements

WARNING! Risk of Fire! Changes or modifications to this unit not expressly approved by the party responsible for compliance could void the user's authority to operate the equipment.

Note: This equipment has been tested and found to comply with the limits for a Class B digital device, pursuant to Part 15 of the FCC Rules and EN298 for multi-functional control. These limits are designed to provide reasonable protection against harmful interference in a residential installation. This equipment generates, uses, and can radiate radio frequency energy and, if not installed and used in accordance with the instructions, may cause harmful interference to radio communications. However, there is no guarantee that interference will not occur in a particular installation. If this equipment does cause harmful interference to radio or television reception, which can be determined by turning the equipment off and on, the user is encouraged to try to correct the interference by one or more of the following measures:

- Reorient or relocate the receiving antenna.
- Increase the separation between the equipment and receiver.
- Connect the equipment into an outlet on a circuit different from that to which the receiver is connected.
- Contact the dealer or an experienced radio TV technician for help.

Changing Temperature Scale

To change the temperature display between Celsius and Fahrenheit, remove the battery cover from the back of the remote control and slide the switch to your desired temperature scale (see Figure 12.5). The screen will automatically change the indicators on the room temperature and set temperature portion.



Figure 12.5 Temperature Scale

Installation of Remote Control Housing

CAUTION! Risk of Fire! DO NOT install damaged or modified components. Warranty will be voided if damaged or modified components are installed.

1. Remove remote control components from packaging.
2. Remove battery cover from the back of the remote by sliding it down and install 3 AAA batteries.

To prevent unintended operation when not using your fireplace for an extended period of time (summer months, vacation, trips, etc):

- Remove batteries from remote control.
 - Unplug switching adapter and remove back-up batteries.
3. Secure the remote control housing on a flat wall surface using the two screws and wall anchors provided. See Figure 12.6.

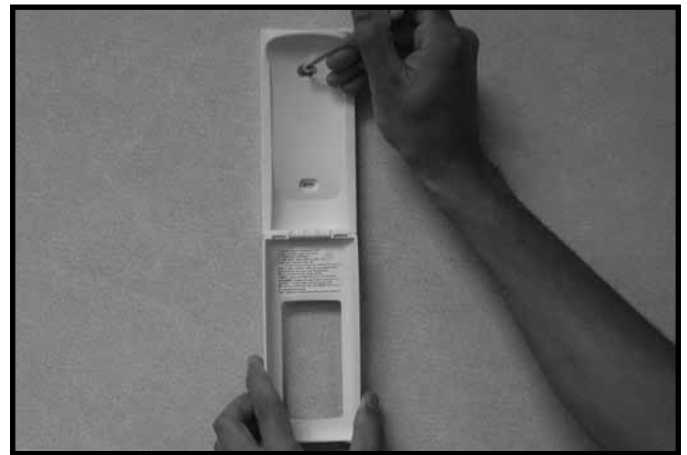

Figure 12.6 Mounting Remote Control Housing

4. Place remote control inside housing. See Figure 12.7.



Figure 12.7 Remote in Housing

5. Close the housing door. See Figure 12.8.



Figure 12.8 Mounting Remote Control Housing

AUX300CE Module Installation

- Insert the 4 hole harness from the AUX300CE module into the 4 pin plug on the control module. See Figure 12.9.

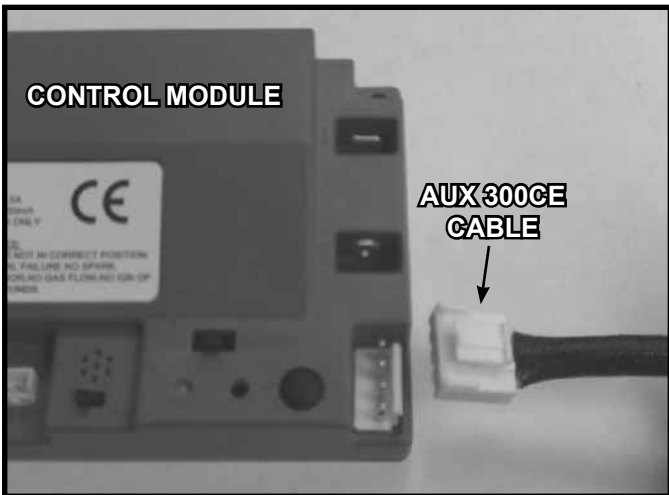

Figure 12.9 AUX 300 module installation

Fan Installation

- Insert the 3 prong plug from the fan into the receptacle located in the AUX300CE module. See Figure 12.10.
- Insert 3 prong plug from AUX300CE module into REM/AUX receptacle of fireplace junction box.

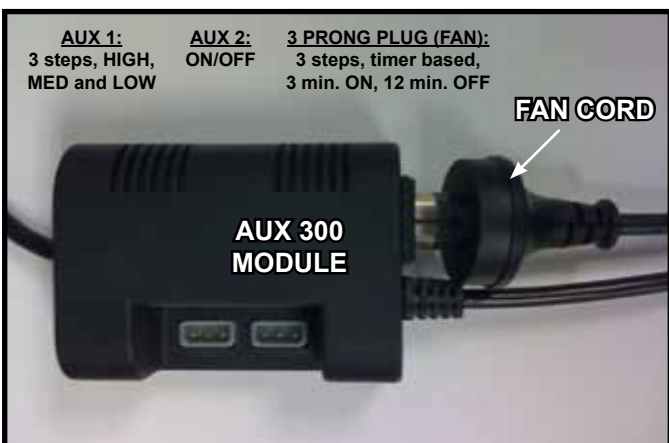

Figure 12.10 Plug Fan into AUX300CE Module

Programming the RC300CE to the Control Module

CAUTION! Risk of burns! DO NOT program the remote control to the control module when fireplace is hot.

- Verify the ON/OFF/REMOTE switch is in the REMOTE position. Green LED light will blink three times and the control module will beep once 5 seconds later when ready. See Figure 7.
- Using a small item (such as a paper clip) press and release the LEARN button located near the ON/OFF/REMOTE switch. See Figure 12.11.
- Control module will beep once and LED will blink green for 10 seconds.
- While the LED is blinking, press the POWER button on the remote control. A double beep will come out of the control module to indicate that it has been programmed successfully.

NOTICE: Up to three remote controls can be programmed into the control module. Simply press a button on the other remote controls during the 10 second programming process to add another remote into the system. It is recommended to program only one RC300CE remote control.

To clear memory in the control module, use a small item (such as a paper clip) to press and release the LEARN button. Control module will beep once and LED will blink green for 10 seconds **DO NOT** press any buttons on the remote during the ten seconds that the green LED blinks. The memory will be cleared. Note that the RC300CE will not be programmed if it's in STANDBY mode. Press the ON/OFF button twice to switch to IDLE mode.

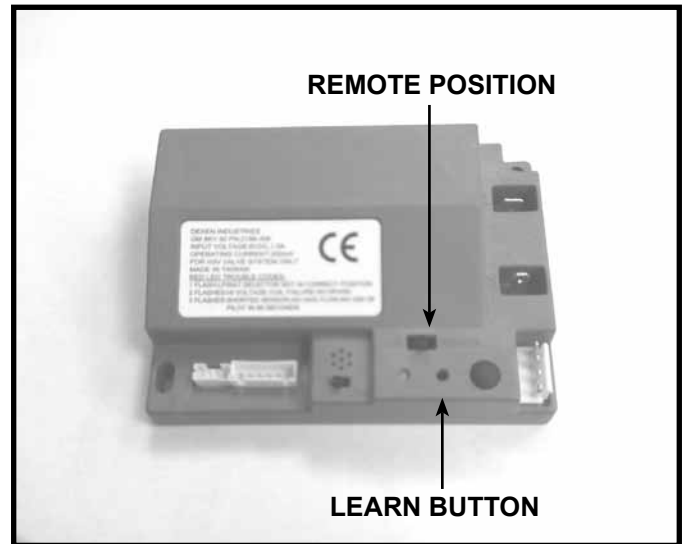
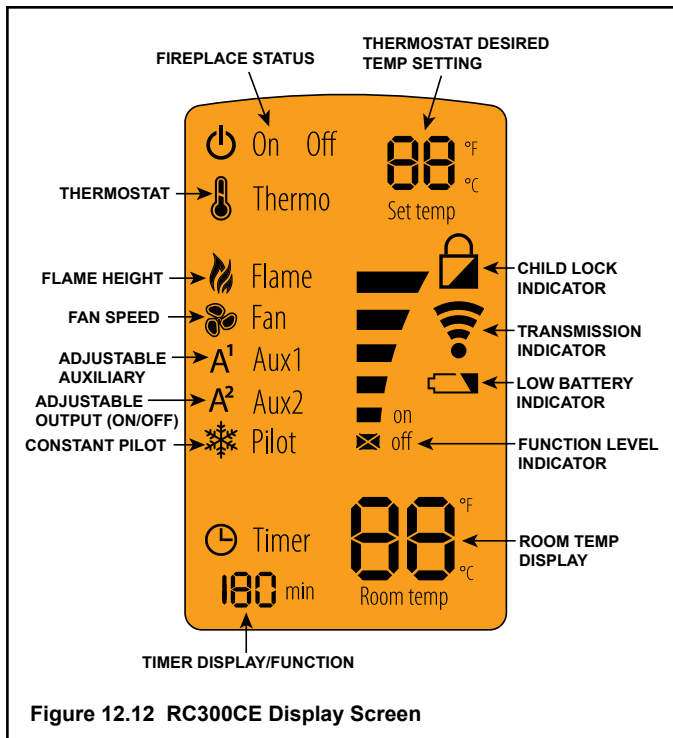

Figure 12.11 Programming RC300CE

Display Screen



Function Buttons

- POWER** Use POWER button to turn the unit on and off.
- Menu** Use MENU button to display the menu functions. Only functions that can be activated will be displayed. *For example: Flame Height will not be displayed when the remote status is OFF.*
- Select** Use the SELECT button to select the current feature.
- UP** Use the UP and DOWN arrows to toggle through the menu functions and value selections in the submenus.
- DOWN**

Idle When Remote is in ON Mode

The remote control will go into an idle mode if no buttons are pressed within 5 seconds. Press any button to resume full functionality. In idle mode only active functions will show on the screen.



Standby mode

The remote control will go into a standby mode if no buttons are pressed within 5 minutes. Press the POWER button to reactivate the remote control to ON mode. Active functions will be displayed

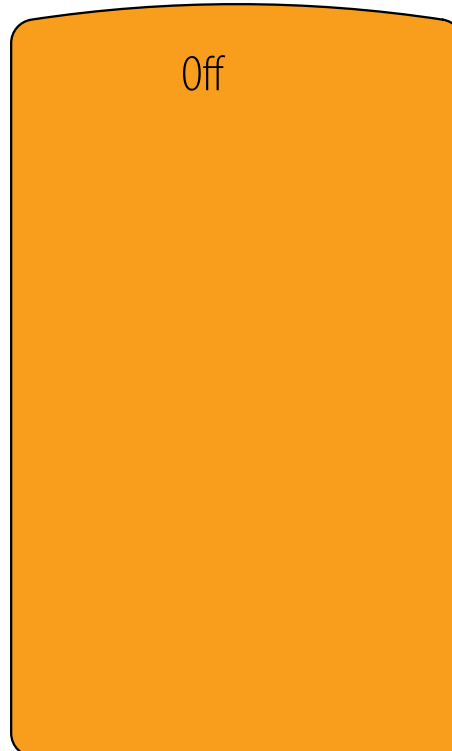

About ON Mode

- All functions can be accessed when the remote control is in the ON mode.
- Only active functions will be displayed when the remote control is in the ON mode. For example: if the fan is the only function that's active, the fan icon and flame will be the only icon shown in the display.

About OFF Mode

Only the following functions can be accessed in the OFF mode:

- AUX1
- AUX2

Only active functions will be displayed when the remote control is in the OFF mode.

Turning ON the Fireplace

- Press and hold the POWER button for 5 seconds to unlock remote, back light will illuminate. Press the POWER button again to turn the fireplace ON. The fireplace will first ignite the pilot. The main burner will be lit, once the pilot flame has been established. The remote will be locked again when the fireplace is turned OFF.

NOTICE: Whenever the fireplace is cycled from OFF to ON, the main burner will light on high for 10 seconds before returning to the previous user setting.

Adjusting Flame Height

- Press the MENU button to activate the menu.
- Using the UP and DOWN arrows highlight the FLAME icon and press SELECT.
- Use the UP and DOWN arrows to adjust the FLAME HEIGHT, then press SELECT. The FLAME HEIGHT can be adjusted to 5 different settings.

NOTICE: FLAME HEIGHT will not be adjustable for first ten seconds when fireplace is turned on.

NOTICE: The system will remember the previous FLAME HEIGHT setting and will automatically adjust after 10 seconds.

Adjusting Fan Speed

- Press the MENU button to activate the menu.
- Using the UP and DOWN arrows highlight the FAN icon and press SELECT.
- Use the UP and DOWN arrows to adjust the FAN SPEED, then press SELECT. The FAN SPEED can be adjusted to 3 different settings: HIGH, MEDIUM, LOW.

NOTICE: The fan has a timer built into the control module. After the fireplace is turned ON the timer will wait for 3 minutes before turning on the fan. In addition, the fan will remain on for 12 minutes after the fireplace has been turned OFF.

NOTICE: Whenever the fan is turned ON, the FAN will start up on the high setting for 10 seconds before adjusting to the previous user setting.

AUX1 Function (Unit dependent Function)

- Press the MENU button to activate the menu.
- Using the UP and DOWN arrows highlight the AUX1 icon and press SELECT.
- Use the UP and DOWN arrows to adjust the AUX1 output, then press SELECT. The AUX1 function can be adjusted to 4 different settings: HI, MED, LOW and OFF.

AUX2 Function (Unit dependent Function)

- Press the MENU button to activate the menu.
- Using the UP and DOWN arrows highlight the AUX2 icon and press SELECT.
- Use the UP and DOWN arrows to turn the AUX2 ON or OFF, then press SELECT. The AUX2 function can be either be turned ON or OFF.

NOTICE: When the fireplace is turned OFF both AUX1 and AUX2 will be turned off. The AUX1 and AUX2 functions can be activated from the remote's OFF mode, when the flame is off. When the fireplace is turned back ON, the AUX1 and AUX2 settings will be restored to the previous setting.

Adjusting Thermostat

- Press the **MENU** button to activate the menu.
- Using the **UP** and **DOWN** arrows highlight the **THERMO** icon and press **SELECT**.
- Use the **UP** and **DOWN** arrows to turn the **THERMO ON** or **OFF**, then press **SELECT** (the **SET TEMP** will start blinking). Using the **UP** and **DOWN** arrows select the desired temperature and press **SELECT**.

NOTICE: If the **THERMO** function is on, the **SET TEMP** can be adjusted at any time by pressing the **UP** and **DOWN** arrows.

NOTICE: As the **ROOM TEMP (RT)** approaches **SET TEMP (ST)**, the remote system will automatically adjust the flame height. If the **RT** rises above **ST**, the fireplace will shut down the main burner. After this, the fireplace will turn back on after the **RT** drops below the **ST**.

NOTICE: The system will remember the previous **TEMPERATURE** setting when **THERMOSTAT** mode is cycled **ON** or **OFF**.

NOTICE: If your installation includes an optional wired **ON/OFF** wall switch, it should be in the **OFF** position when using the **RC300CE** in thermostat mode.

Adjusting Timer

- Press the **MENU** button to activate the menu.
- Using the **UP** and **DOWN** arrows highlight the **TIMER** icon and press **SELECT**.
- Use the **UP** and **DOWN** arrows to turn the **TIMER ON** or **OFF**, then press **SELECT**. Using the **UP** and **DOWN** arrows select the desired set time and press **SELECT**. Timer operates in increments of 15, 30, 45, 60, 90, 120 and 180 minutes.

Activating/Deactivating Constant Pilot

- Press the **MENU** button to activate the menu.
- Using the **UP** and **DOWN** arrows highlight the **PILOT** icon and press **SELECT**.
- Use the **UP** and **DOWN** arrows to turn the **CONSTANT PILOT ON** or **OFF**, then press **SELECT**.

NOTICE: A beep will come from the control module indicating **CONSTANT PILOT** has been activated. A double beep will come from the control module indicating **CONSTANT PILOT** has been deactivated.

Setting the Child Lock

- Press and hold the **MENU** and **UP** arrow buttons simultaneously for 4 seconds to enable or disable the child lock feature.

NOTICE: No functions will be usable until child lock feature is disabled.

Power Outage

- If fireplace battery backup system **IS** installed at time of power outage, fireplace operation will not be interrupted.
- If fireplace battery backup system **IS NOT** installed at time of power outage, fireplace will shut off. To resume fireplace operation, install battery backup.

NOTICE: Battery polarity must be correct or module damage will occur.

Manual Fireplace Shutoff

In the unlikely event that the remote wall switch malfunctions and will not turn off the fireplace, call your dealer for service assistance. In the meantime, you may choose one of the following actions to turn off the fireplace:

CAUTION! Risk of burns! Fireplace surfaces are hot when operating and during cool down. Use care and wear gloves when opening the front and accessing components inside the fireplace.

Check remote screen for battery level indicator, replace the batteries if low battery is indicated (See Figure 12.12).

Turn off the control module:

- Open or remove the decorative front to access the control module.
- Move switch to **OFF** (See Figure 12.4).

Disconnect power to the control module:

- Open or remove the decorative front to access ___ to the junction box and/or back-up batteries.
- Unplug the control module and/or remove back-up batteries.

Shut off gas to the appliance:

- Open or remove the decorative front and locate the gas shut-off valve to the left of the gas control.
- Rotate the shut off valve 90 degrees to turn off gas supply.

Turn off power to the fireplace (if back-up batteries are not installed):

- Locate house circuit breaker for fireplace.
- Turn off the circuit breaker.

Frequently Asked Questions/Troubleshooting

Symptom	Possible Cause	Corrective Action
Remote control will not transmit	Batteries	Verify batteries are functional and installed correctly.
	Remote control is in Child Lock mode	Disengage Child Lock mode.
	Buttons not being pressed firmly	Press button firmly for one to two seconds to ensure transmission to module.
Control module will not take commands from remote control	Control module is not in "REMOTE" mode	Ensure module switch is set to REMOTE.
	Control module and remote control are not programmed to each other	The control module will beep when it successfully receives a command. If it does not beep, clear module memory and reprogram the remote control.
	Control module is unplugged. In case of power outage, backup batteries are depleted or missing	If the transmission indicator comes on when power button is pressed, verify that the control module is plugged in the fireplace junction box located in the controls area. Also verify that the batteries are installed in the battery pack.
Fan does not turn on when fireplace is started	Built in time delay	The fireplace must run for three minutes in order for the fan to engage.
Fan does not turn off when fireplace turned off	Built in time delay	The fan will run for twelve minutes after the fireplace is turned off.
Fireplace shuts down after extended periods	Built-in timer	The fireplace will automatically shut down after nine hours of continuous operation if it does not receive a command from the remote.
Fireplace is on but will not shut off with the remote control	External wired wall switch	The fireplace cannot be turned off by remote if an external wired switch is installed and in the ON position. Turn external wall switch to OFF.
	Remote control or control module failure	At control module, turn off fireplace by sliding the ON/OFF/REMOTE switch to OFF. Warning! Risk of Burns! Fireplace is hot. Use caution when accessing module.

13 Finishing

A. Mantel and Wall Projections

WARNING! Risk of Fire! Comply with all minimum clearances as specified. Framing or finishing material closer than the minimums listed must be constructed entirely of non-combustible materials (i.e., steel studs, concrete board, etc).

Combustible Mantels

No mantels are allowed when using Studio-CE fronts.

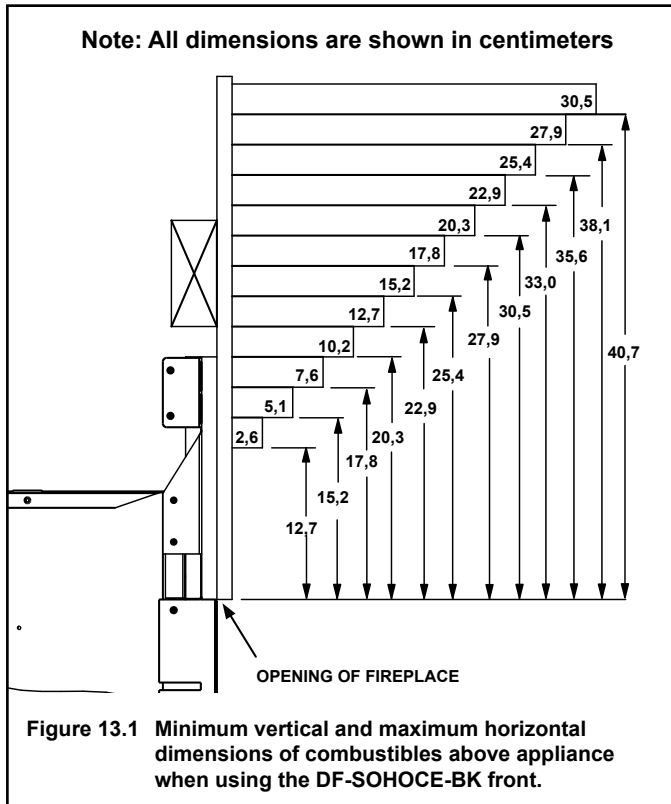

- Observe all clearances when applying combustible materials.
- Seal joints between the finished wall and appliance top and sides using a 300 °F (149 °C) minimum sealant.

WARNING! Risk of Fire! DO NOT apply combustible materials beyond the minimum clearances. Comply with all minimum clearances to combustibles as specified in this manual. Overlapping materials could ignite and will interfere with proper operation of doors and louvers.

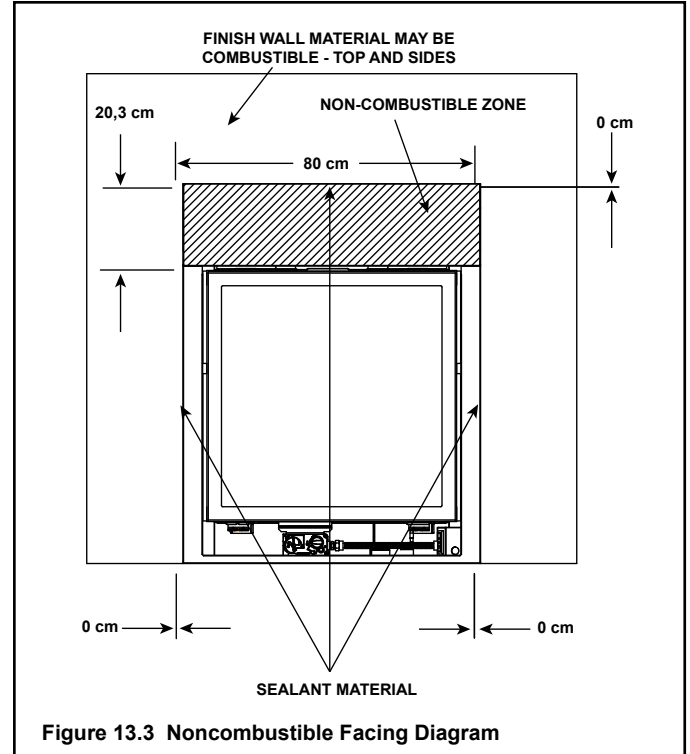

Combustible Mantel Legs or Wall Projections

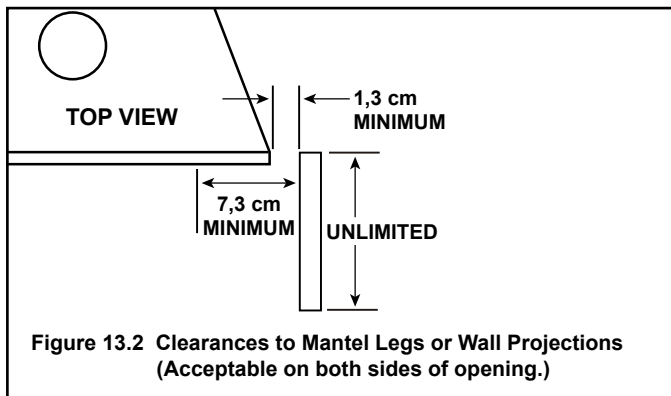

B. Facing Material

- Facing and/or finishing materials must not interfere with air flow through louvers, operation of louvers or doors, or access for service.
- Facing and/or finishing materials must never overhang into the glass opening.

C. Framing and Finishing Instructions

Finishing Instructions

It is important to follow the framing and finishing instructions to ensure proper placement of fireplace into the surrounding framing/finishing materials.

Wall sheathing materials 1,3 cm thick are specified in this installation manual to properly align with the factory-installed non combustibile material.

WARNING! Risk of Fire! DO NOT remove the factory-installed non-combustible board or cover it with combustibile material, such as:

- Drywall (gypsum board)
- Plywood
- Materials that do not meet the ASTM E 136 Non-combustibility standard (below).

Removal of factory-installed, non-combustible board and/or use of materials not meeting the ASTM E 136 standard may cause fire.

Gypsum wallboard (drywall) joints adjacent to the fireplace opening require special attention to minimize potential development of cracking. Hearth and Home Technologies recommends the following steps to minimize potential cracks in the finished drywall around the fireplace opening:

- When installing gypsum wallboard around the fireplace, install the hole for the fireplace opening in a single wallboard sheet, if possible. This will minimize the joints adjacent to the fireplace opening.
- The factory-supplied non-combustible board and the gypsum wallboard must join on the structural framing, where applicable. Wallboard and non-combustible board should be fastened to the framing with at least 1.25" long screw fasteners, located within 1.5" from each corner, and at no more than 12" intervals along the joint length.
- The wall-board joints should be finished with a Taping Coat, followed by at least two subsequent Finish Coats of joint compound.
- For the initial Taping Coat, it is critical that a general-purpose chemically hardening joint compound, such as SHEETROCK™ Brand Durabond™ Setting-Type Joint Compound, be used to fill the joint and embed the mesh tape. Fiberglass-mesh tape is recommended because it will provide a more crack-resistant joint than one finished with paper tape. Let the Taping Coat properly cure before applying subsequent Finish Coats.

- For the second and third finishing coats, it is acceptable to use a light-weight joint compound and standard application, curing and sanding methods.
- Do not operate the fireplace during the drywall finishing process. Allow the finish coat to cure for at least 24 hours prior to using the appliance.

Painting

If desired finishing includes a painted wall, 100% acrylic latex with compatible primer is recommend around the appliance. Oil-based or standard acrylic paints may discolor due to heat exposure.

Wallboard Joint-Crack Prevention and Repair

Wallboard joints around the fireplace will be affected by exposure to elevated temperatures, along with other environmental and structural factors. The specific methods presented in the previous section will help prevent or minimize development of cracks.

If a crack does emerge adjacent the fireplace, it can be permanently repaired by filling it with spackling paste or paintable latex caulk, followed by repainting.

14 Appliance Setup

A. Remove Fixed Glass Assembly

See Section 9.B.

B. Remove the Shipping Materials

Remove shipping materials from inside or underneath the firebox.

C. Clean the Appliance

Clean/vacuum any sawdust that may have accumulated inside the firebox or underneath in the control cavity.

D. Accessories

Install approved accessories per instructions included with accessories. Contact your dealer for a list of approved accessories.

WARNING! Risk of Fire and Electric Shock! Use ONLY Hearth & Home Technologies-approved optional accessories with this appliance. Using non-listed accessories could result in a safety hazard and will void the warranty.

DO NOT MODIFY THIS APPLIANCE



Figure 14.1

CAUTION: Logs are fragile. Carefully remove the logs from the packaging.

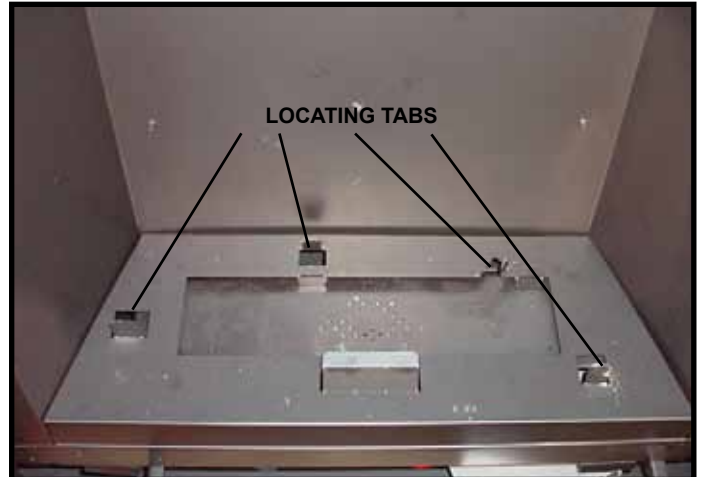

Figure 14.2



Figure 14.3

Step 1. Place Log #1 (SRV2111-700) against rear right tab with its slot over center locating tab.



Figure 14.4

Step 2. Place Log #2 (SRV2111-701) onto base pan such that Log #2 fits in groove of Log #1. Push it back against the left hand side locating tab. Ensure burner ports are not covered by logs.



Figure 14.5

Step 3. Place Log #3 (SRV2111-702) so the top rests on Log #1 against Log #2. The base slot on Log #3 will fit over the locating tab on the front right hand side.

F. Install Media Rock Kit

This kit is used in place of the logs in a SOHO-CEB unit. Alternate media and reflective firebox liner is provided.

CAUTION! Risk of Cuts, Abrasions or Flying Debris. Wear protective gloves and safety glasses during installation. Sheet metal edges are sharp.

CONTENTS OF KIT:

- Reflective Firebox Liner (Optional)
- Rock Tray
- Rock or Onyx



Figure 14.6

1. Remove the front and glass from the unit and set aside. Remove the logs (if installed) from the unit and either discard or save for later use.
2. Fold down the log locating tabs (if bent up) on the base pan so they are parallel with the burner. See Figure 14.7.
3. Proceed to step 4 if the firebox liner is not being installed. Install the firebox liner by placing it on the base pan of the fireplace and sliding it back until it contacts the back of the fireplace. See Figure 14.7.

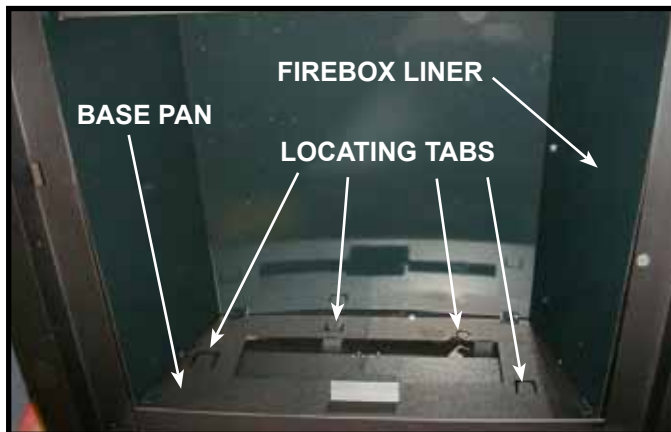

Figure 14.7

4. Set the rock tray on top of the base pan. See Figure 14.7.



Figure 14.8

5. Spread the rock or onyx evenly across the rock tray. See Figure 14.9. **DO NOT** place rocks in burner area or in front of pilot burner. See Figure 14.8.

⚠ WARNING	
	Delayed Ignition Risk
	<ul style="list-style-type: none"> • Do NOT place rocks on burner. • Do NOT place rocks in a position that they may fall on the burner. Fireplace will not function properly. Delayed ignition may occur.



Figure 14.9

6. Reinstall the glass frame and front.

G. IPI Module Reset Switch

The appliance is shipped with the IPI reset switch installed and positioned to work with the DF-SOHOCE-BK decorative front. If using the Studio front, the switch assembly should be re-positioned as shown below; this will keep the switch accessible during fireplace operation. Ensure that no wires are damaged or disconnected during the re-positioning process.

1. Remove two screws securing the switch assembly to the fireplace. See Figure 14.10.

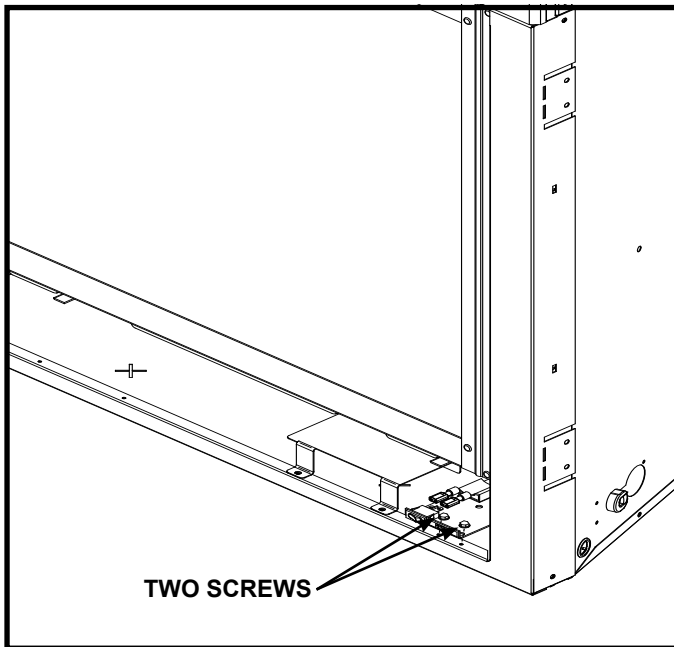

Figure 14.10

2. Bend metal bracket as indicated in Figure 14.11.

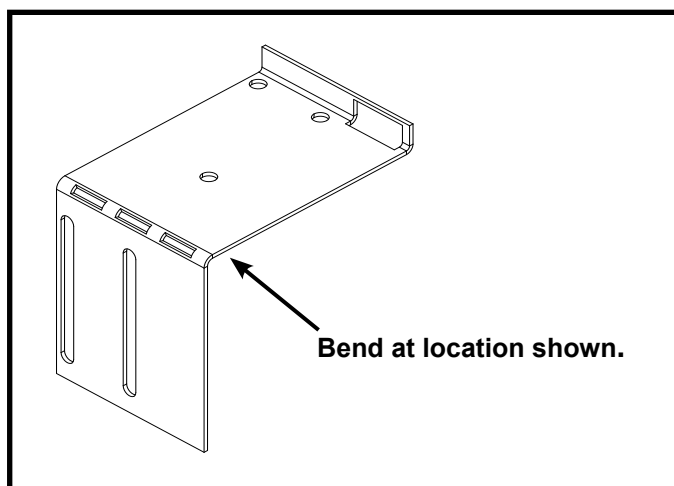

Figure 14.11

3. Position and secure the switch assembly to the lower right side of the surround as shown below. It should be placed directly against the surround face or finishing materials. See Figure 14.12.

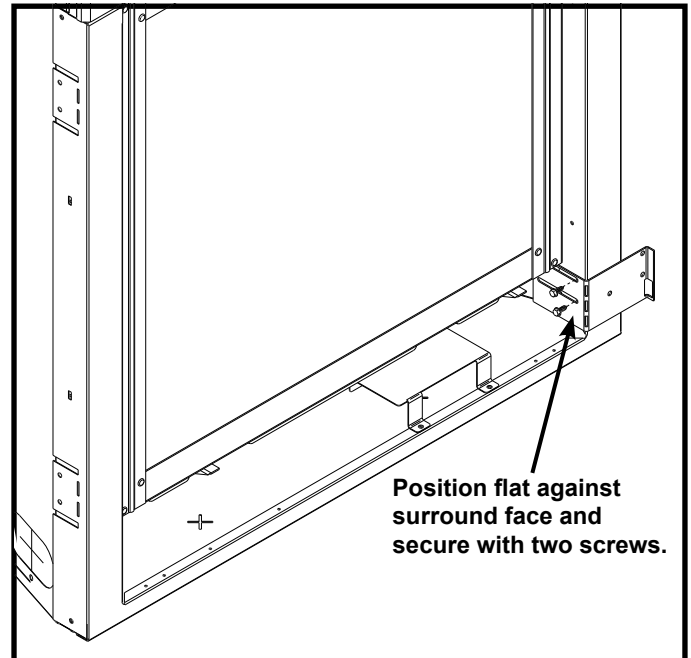

Figure 14.12

15 Troubleshooting

With proper installation, operation, and maintenance your gas appliance will provide years of trouble-free service. If you do experience a problem, this troubleshooting guide will assist a qualified service technician in the diagnosis of a problem and the corrective action to be taken. This troubleshooting guide can only be used by a qualified service technician. Contact your dealer to arrange a service call by a qualified service technician.

A. IntelliFire Plus™ Ignition System

Symptom	Possible Cause	Corrective Action
1. Pilot won't light. The ignitor/module makes noise, but no spark.	a. Incorrect wiring.	Verify "S" wire (white) for sensor and "I" wire (orange) for ignitor are connected to correct terminals on module and pilot assembly.
	b. Loose connections or electrical shorts in the wiring.	Verify no loose connections or electrical shorts in wiring from module to pilot assembly. Verify connections underneath pilot assembly are tight; also verify connections are not grounding out to metal chassis, pilot burner, pilot enclosure, mesh screen if present, or any other metal object.
	c. Ignitor gap is too large.	Verify gap of igniter to right side of pilot hood. The gap should be approximately 3 mm.
	d. Module.	Turn ON/OFF rocker switch or wall switch to OFF position. Remove ignitor wire "I" from module. Place a grounded wire about 5 mm away from "I" terminal on module. Place ON/OFF rocker switch or wall switch in ON position. If there is no spark at "I" terminal module must be replaced. If there is a spark at "I" terminal, module is fine. Inspect pilot assembly for shorted sparker wire or cracked insulator around electrode. Replace pilot if necessary.
2. Pilot won't light, there is no noise or spark.	a. No power or transformer installed incorrectly.	Verify that transformer is installed and plugged into module. Check voltage of transformer under load at spade connection on module with ON/OFF switch in ON position. Acceptable readings of a good transformer are between 6.4 and 6.6 volts AC.
	b. A shorted or loose connection in wiring configuration or wiring harness.	Remove and reinstall the wiring harness that plugs into module. Verify there is a tight fit. Verify pilot assembly wiring to module. Remove and verify continuity of each wire in wiring harness. Replace any damaged components.
	c. Improper wall switch wiring.	Verify that 230 VAC power is "ON" to junction box.
	d. Module not grounded.	Verify black ground wire from module wire harness is grounded to metal chassis of appliance.
	e. Module.	Turn ON/OFF rocker switch or wall switch to OFF position. Remove ignitor wire "I" from module. Place ON/OFF rocker switch or wall switch in ON position. If there is no spark at "I" terminal module must be replaced. If there is a spark at "I" terminal, module is fine. Inspect pilot assembly for shorted sparker wire or cracked insulator around electrode.
3. Pilot sparks, but Pilot will not light.	a. Gas supply.	Verify that incoming gas line ball valve is "open". Verify that inlet pressure reading is within acceptable limits, inlet pressure must not be exceeded.
	b. Ignitor gap is incorrect.	Verify that spark gap from ignitor to pilot hood is 3 mm.
	c. Module is not grounded.	Verify module is securely grounded to metal chassis of appliance.
	d. Module voltage output / Valve/Pilot solenoid ohms readings.	Verify battery voltage is at least 5.7 volts. Replace batteries if voltage is below 5.7.

IntelliFire Plus™ Ignition System - (continued)

Symptom	Possible Cause	Corrective Action
<p>4. Pilot lights but continues to spark, and main burner will not ignite. (If the pilot continues to spark after the pilot flame has been lit, flame rectification has not occurred.)</p>	<p>a. A shorted or loose connection in flame sensing rod.</p>	<p>Verify all connections to wiring diagram in manual. Verify connections underneath pilot assembly are tight. Verify connections are not grounding out to metal chassis, pilot burner, pilot enclosure or screen if present, or any other metal object.</p>
	<p>b. Poor flame rectification or contaminated flame sensing rod.</p>	<p>With fixed glass assembly in place, verify that flame is engulfing flame sensing rod on left side of pilot hood. Flame sensing rod should glow shortly after ignition. Verify correct pilot orifice is installed and gas inlet is set to pressure specifications. Polish flame sensing rod with fine steel wool to remove any contaminants that may have accumulated on flame sensing rod.</p>
	<p>c. Module is not grounded.</p>	<p>Verify module is securely grounded to metal chassis of appliance. Verify that wire harness is firmly connected to the module.</p>
	<p>d. Damaged pilot assembly or contaminated flame sensing rod.</p>	<p>Verify that ceramic insulator around the flame sensing rod is not cracked, damaged, or loose. Verify connection from flame sensing rod to white sensor wire. Polish flame sensing rod with fine steel wool to remove any contaminants that may have accumulated on flame sensing rod. Verify continuity with a multimeter with ohms set at lowest range. Replace pilot if any damage is detected.</p>
	<p>e. Module.</p>	<p>Turn ON/OFF rocker switch or wall switch to OFF position. Remove ignitor wire "I" from module. Place ON/OFF rocker switch or wall switch in ON position. If there is no spark at "I" terminal module must be replaced. If there is a spark at "I" terminal, module is fine.</p>

16 Reference Materials

A. Appliance Dimension Diagram

Dimensions are actual appliance dimensions. Use for reference only. For framing dimensions and clearances refer to Section 5.

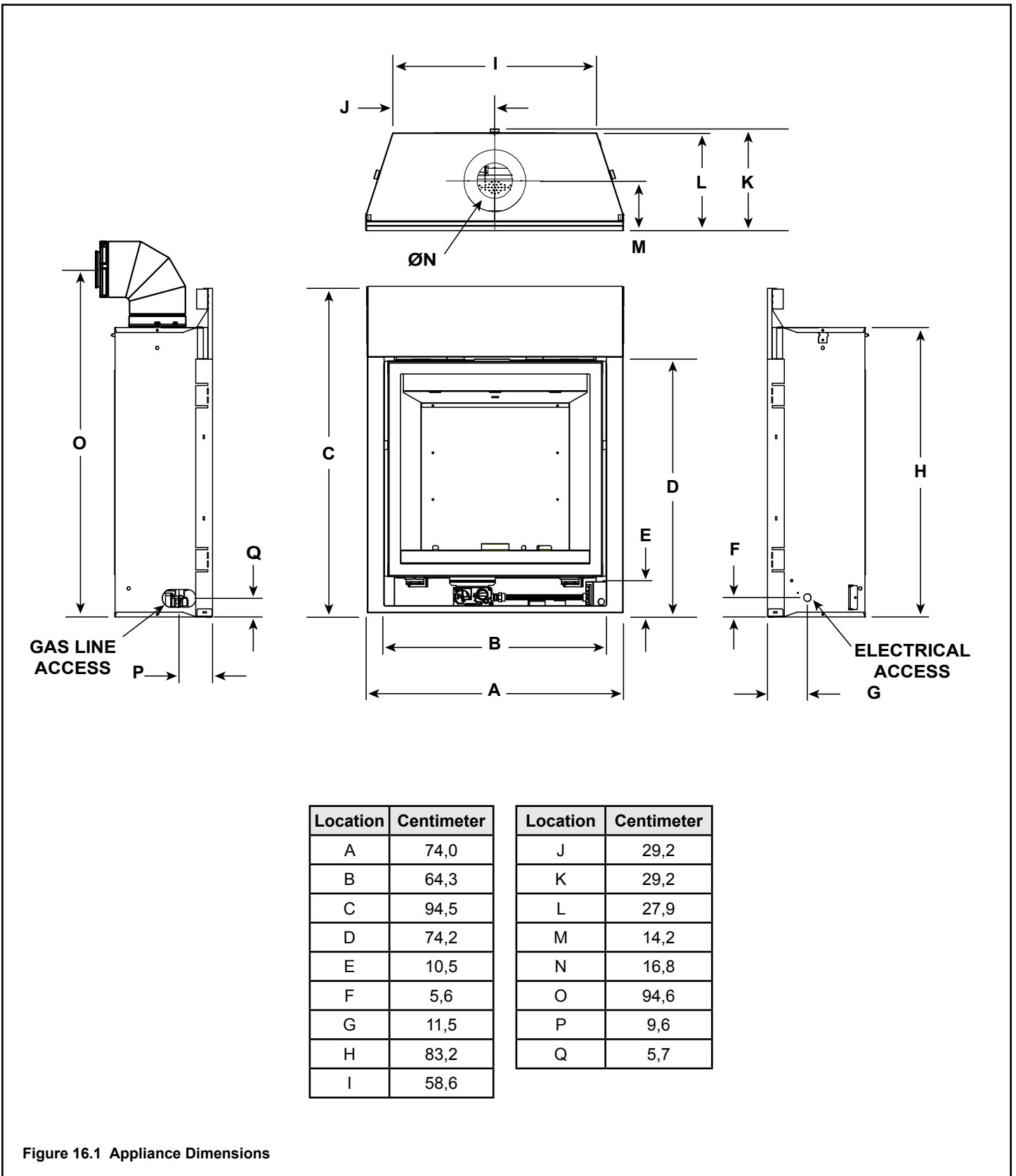
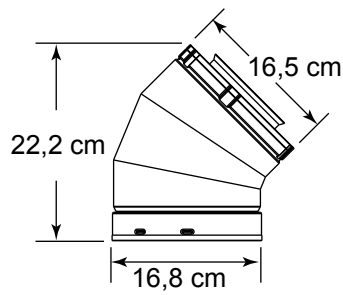

Figure 16.1 Appliance Dimensions

B. Maintenance Tasks

Inspect	Maintenance Tasks
Doors	1. Inspect for scratches, dents or other damage and repair as necessary.
	2. Verify no obstructions to airflow.
	3. Verify maintenance of proper clearance to combustible household objects.
Gasket Seal, Glass Assembly and Glass	1. Inspect gasket seal and its condition.
	2. Inspect glass panels for scratches and nicks that can lead to breakage when exposed to heat.
	3. Confirm there is no damage to glass or glass frame. Replace as necessary.
	4. Verify that latches engage properly, clip studs are not stripped, and glass attachment components are intact and operating properly. Replace as necessary.
	5. Clean glass. Replace glass assembly if severely coated with silicate deposits that cannot be removed.
Valve Compartment and Firebox Top	1. Vacuum and wipe out dust, cobwebs, debris or pet hair. Use caution when cleaning these areas. Screw tips that have penetrated the sheet metal are sharp and should be avoided.
	2. Remove any foreign objects.
	3. Verify unobstructed air circulation.
Logs	1. Inspect for broken, damaged, or missing logs. Replace as necessary.
	2. Verify correct log placement and no flame impingement causing sooting. Correct as necessary.
Firebox	1. Inspect for paint condition, warpage, corrosion or perforation. Sand and repaint as necessary.
	2. Replace appliance if firebox has been perforated.
Burner Ignition and Operation	1. Verify burner is properly secured and aligned with pilot or igniter.
	2. Clean off burner top, inspect for plugged ports, corrosion or deterioration. Replace burner if necessary.
	3. Replace ember materials with new dime-size and shape pieces. Do not block ports or obstruct lighting paths.
	4. Check for smooth lighting and ignition carryover to all ports. Verify there is no ignition delay.
	5. Inspect for lifting or other flame problems.
	6. Inspect orifice for soot, dirt or corrosion.
	7. Verify manifold and inlet pressures. Adjust regulator as required.
	8. Inspect pilot flame strength. Clean or replace orifice as necessary.
	9. Inspect thermocouple/thermopile or IPI sensor rod for soot, corrosion and deterioration. Polish with fine steel wool or replace as required.
Flueing	1. Inspect venting for blockage or obstruction such as bird nests, leaves, etc.
	2. Confirm that termination cap remains clear and unobstructed by plants, etc.
	3. Verify that termination cap clearance to subsequent construction (building additions, decks, fences or sheds) has been maintained.
	4. Inspect for corrosion or separation.
	5. Verify weather stripping, sealing and flashing remains intact.
Remote controls	1. Verify operation of remote.
	2. Replace batteries in remote transmitters and battery-powered receivers.

C. Vent Components Diagrams



SLP-45 - 45° Elbow

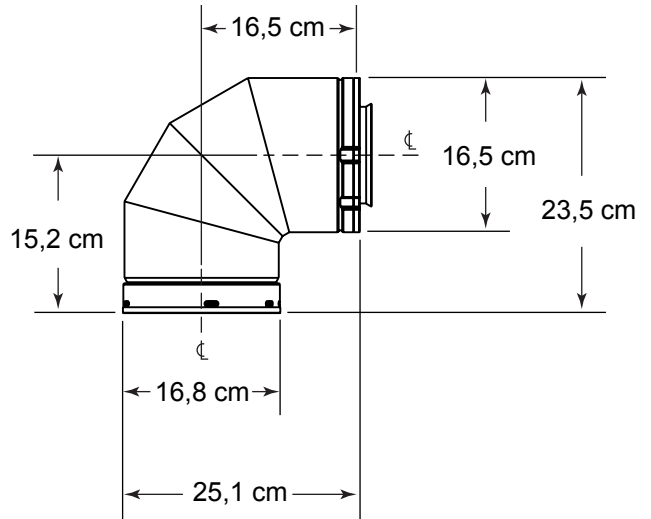

SLP90- 90° Elbow

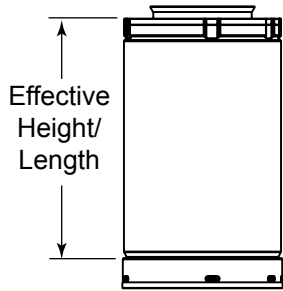

SLP-PIPE

Effective Height/Length

Pipe	cm	mm
SLP4	10,2	102
SLP6	15,2	152
SLP12	30,5	305
SLP24	61	610
SLP36	91,4	914
SLP48	121,9	1219
SLP6A	5 - 15	51 - 152
SLP12A	5 - 30	51 - 305

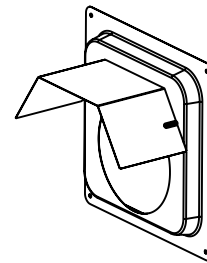

**SLP-WS
Wall Shield Firestop**

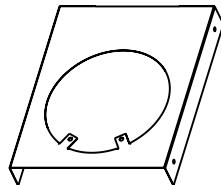

**SLP-HVS
Horizontal Pipe
Support**

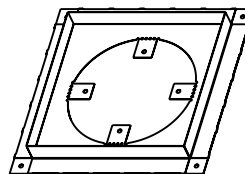

**SLP-FS
Ceiling Firestop**

Figure 16.2 SLP Series Vent Components

C. Vent Components Diagrams (continued)

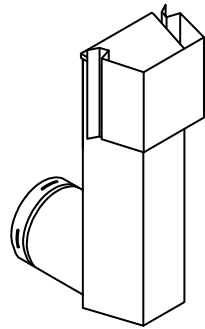

SLK-SNKD
Snorkel
Termination Cap

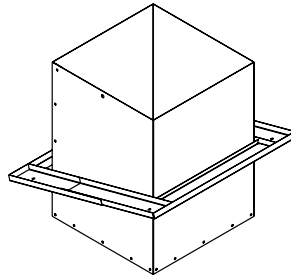

SLP-CCS-BK
Cathedral Ceiling
Support Box-Black

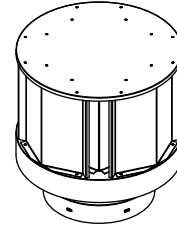

SLP-TVHW
Vertical
Termination Cap

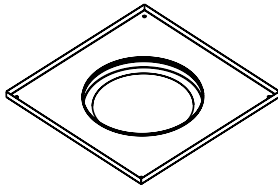

SLP-DCF-BK
Ceiling Firestop
Black

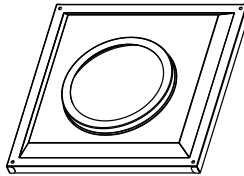

SLP-WT-BK
Wall Thimble-Black

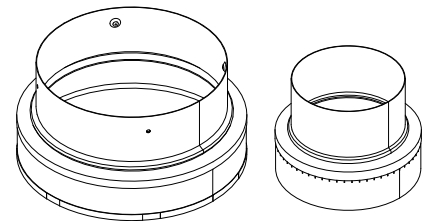

SL-2DVP
Adapter

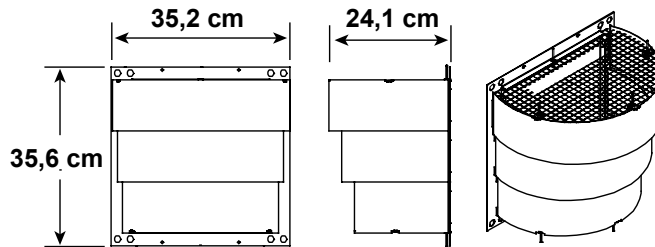

DRC-RADIUS
Cap Shield

Figure 16.3 SLP Series Vent Components

C. Vent Components Diagrams (continued)

Note: Heat shields **MUST** overlap by a minimum of 3,8 cm. The heat shield is designed to be used on a wall 10,2 cm to 18,4 cm thick. If wall thickness is less than 10,2 cm the existing heat shields must be field trimmed.

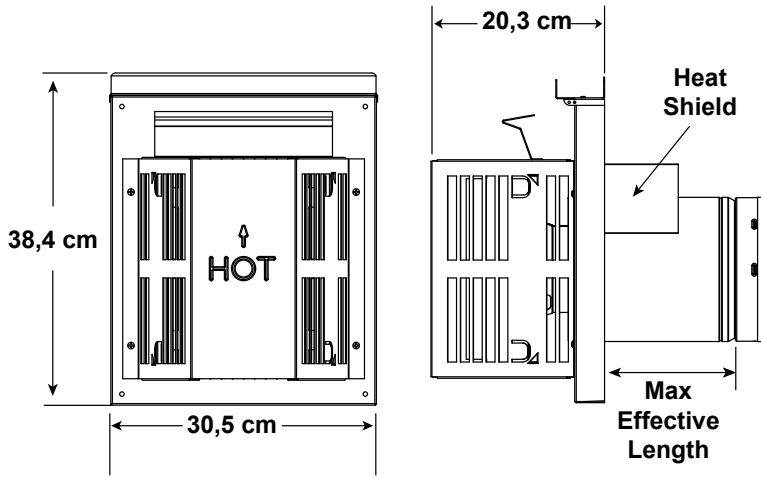

SLP-TRAP
Horizontal Termination Cap

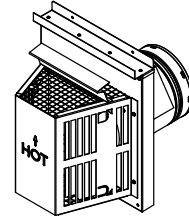

Term Cap	Minimum Effective Length	Maximum Effective Length
SLP-TRAP2	13,7 cm	23,8 cm

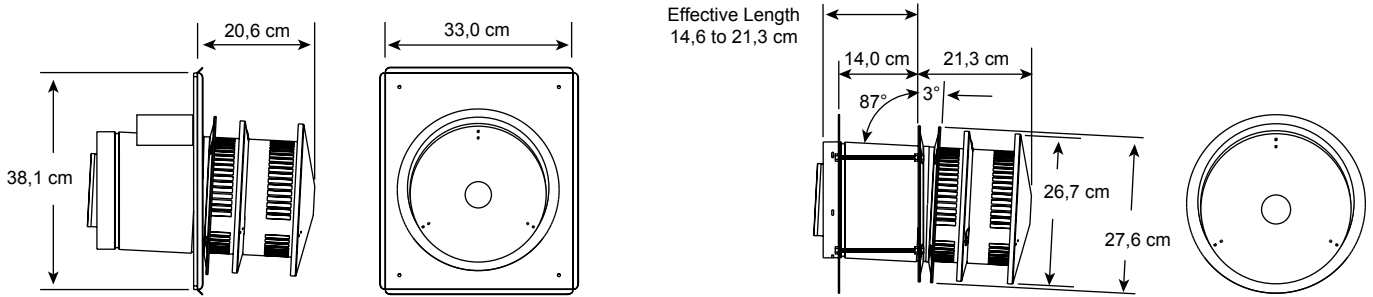

SLP-HRC-SS
SLP-HRC-ZC-SS
HORIZONTAL TERMINATION CAP

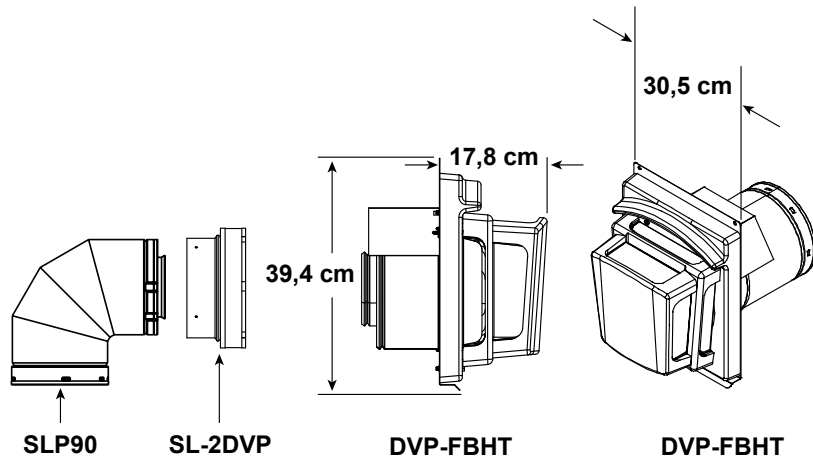

SLP90

SL-2DVP

DVP-FBHT

DVP-FBHT

Figure 16.4 SLP Series Vent Components

Log Set Assembly

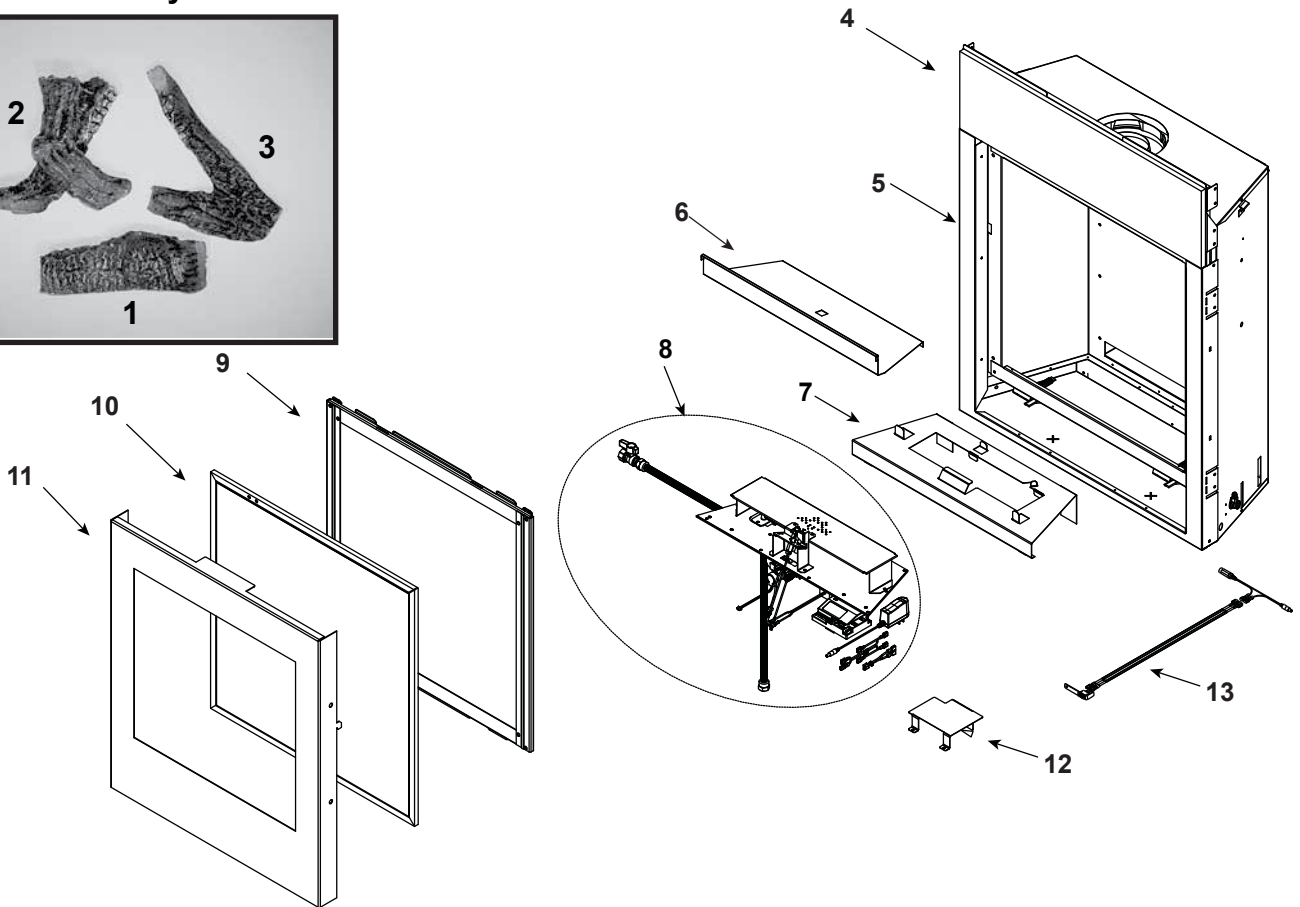

IMPORTANT; THIS IS DATED INFORMATION. When requesting service or replacement parts for your appliance please provide model number and serial number. All parts listed in this manual may be ordered from an authorized dealer.

ITEM	PART DESCRIPTION	COMMENTS	PART NUMBER
	Log Set Assembly		LOGS-SOHOCE
1	Log 1		SRV2111-700
2	Log 2		SRV2111-701
3	Log 3		SRV2111-702
4	Non-combustible Board		2111-148
5	Surround		2077-112
6	Inner Restrictor		2111-142
7	Base Pan		2111-101
8	Burner Assembly/Valve Assembly		Refer to Valve page
9	Glass Assembly		GLA-SOHOCE
10	Mesh Assembly		2077-011
11	Decorative Front		DF-SOHOCE-BK
12	Module Heat Shield		2111-166
13	Reset Switch Assembly		2111-060

Additional service part numbers on the following page.

3/13

#8 Valve Assembly

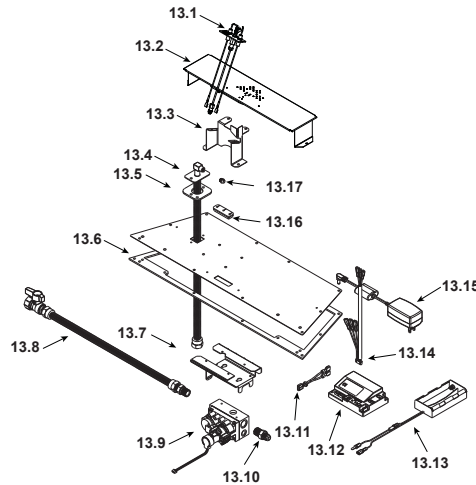

IMPORTANT; THIS IS DATED INFORMATION. When requesting service or replacement parts for your appliance please provide model number and serial number. All parts listed in this manual may be ordered from an authorized dealer.

ITEM	PART DESCRIPTION	COMMENTS	PART NUMBER
8.1	Pilot Assembly N	Pre 0023549474	2198-014
		Post 0023549474	2090-012
	Pilot Assembly B & P	Pre 0023549474	2198-015
		Post 0023549474	2090-013
8.2	Burner Assembly N		2111-020
	Burner Assembly P		2111-022
	Burner Assembly B		2111-024
8.3	Pilot Bracket		2111-123
8.4	Flex Tube Assembly		530-302A
8.5	Burner Neck Gasket		438-407
8.6	Valve Plate Gasket		2077-138
8.7	Valve Bracket		2189-117
8.8	Flex Ball Valve Assembly		2098-320A
8.9	Valve N		2166-302
	Valve B & P		2166-303
8.10	Male Connector	Pkg of 5	303-315/5
8.11	Jumper Wire		2187-198
8.12	Module , IPI 30 Gray		2166-306
8.13	Battery Pack**		4067-223
8.14	Wire Harness		2166-304
8.15	Transformer		2166-305
8.16	3-Hole Grommet		2118-420
8.17	Burner Orifice N (#50C)		582-850
	Burner Orifice P (#58C)		582-858
	Burner Orifice B (#61C)		582-861

**Fuse for battery pack can be sourced locally, not a warranty item. Specs are 500mA~10A 3/4" long

Additional service part numbers on the following page.

No one builds a better fire

Beginning Manufacturing Date: Jan 2011

Ending Manufacturing Date: Active

IMPORTANT; THIS IS DATED INFORMATION. When requesting service or replacement parts for your appliance please provide model number and serial number. All parts listed in this manual may be ordered from an authorized dealer.

ITEM	PART DESCRIPTION	COMMENTS	PART NUMBER
	Bracket, Header		2111-128
	Glass Latch Assembly	Pkg of 2	33858/2
	Glass Latch Assembly	Qty 2 req	339-121A
	Heat Shield		2166-718
	Junction Power Cord-240 V		2166-374
	JunperWire, Wall Switch		2179-300
	Mineral Wool Embers		050-721
	Non-comb Board		2077-148
	Rocker Switch		2206-299
	Rope Ring		045-455
	Wire Assembly, Reset Module		2201-030
	Conversion Kits		
	Natural Gas to Propane or Butane		N2PB-SOHO-CEB
	Propane or Butane to Natural Gas		PB2N-SOHO-CEB
	Propane to Butane or Butane to Propane		P2B-SOHO-CEB
	Pilot Orifice N	Pre 0023549474	2098-520
		Post 0023549474	593-528
	Pilot Orifice P	Pre 0023549474	2098-512
		Post 0023549474	593-527
	Pilot Orifice B	Post 0023549474	593-529
	Regulator N		NGK-DXV-50
	Regulator P		LPK-DXV-50
	Optional Accessories		
	Blower, RC300, & AUX 300 CE		GFK-240V-RC300
	Reflective Panel Liner		SohoCE-SSLINER

Rock Media Option



Rock Media	Black	MEDIA-BK-GEMS
	White	MEDIA-WH-GEMS
	River Rock	MEDIA-STONES
Rock Media with Liner and Flame pan	Black	SohoCE-ONYX
	White	SohoCE-OPAL
	River Rock	SohoCE-Rock
Wireless Wall Switch		RC100-HNG

E. Contact Information



No one builds a better fire

Heat & Glo, a brand of Hearth & Home Technologies
7571 215th Street West, Lakeville, MN 55044
www.heatnglo.com

Please contact your Heat & Glo dealer with any questions or concerns.
For the location of your nearest Heat & Glo dealer,
please visit www.heatnglo.com.

- NOTES -

NOTICE		
	DO NOT DISCARD THIS MANUAL	
<ul style="list-style-type: none">• Important operating and maintenance instructions included.	<ul style="list-style-type: none">• Read, understand and follow these instructions for safe installation and operation.	<ul style="list-style-type: none">• Leave this manual with party responsible for use and operation.

→ This product may be covered by one or more of the following patents: (United States) 5601073, 5613487, 5647340, 5890485, 5941237, 6006743, 6019099, 6053165, 6145502, 6374822, 6484712, 6601579, 6769426, 6863064, 7077122, 7098269, 7258116, 7470729, 8147240 or other U.S. and foreign patents pending.

2000-945B

Printed in U.S.A. - Copyright 2013