

Model:
SL-350TRS-CE-D

Installers Guide

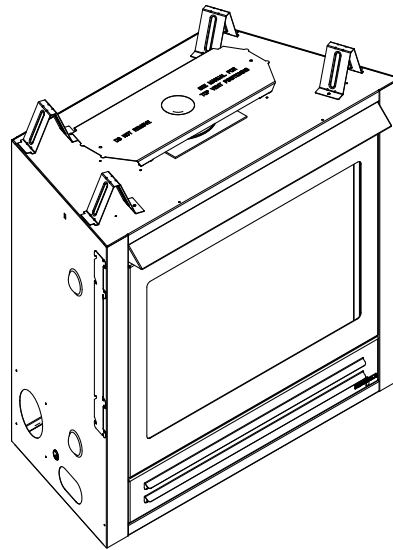

CE
0086

⚠ WARNING: If the information in these instructions is not followed exactly, a fire or explosion may result causing property damage, personal injury, or death.

- Do not store or use gasoline or other flammable vapors and liquids in the vicinity of this or any other appliance.
- **What to do if you smell gas**
 - Do not try to light any appliance
 - Do not touch any electrical switch. Do not use any phone in your building.
 - Immediately call your gas supplier from a neighbor's phone. Follow the gas supplier's instructions.
 - If you cannot reach your gas supplier, call the fire department.
- Installation and service must be performed by a qualified installer, service agency, or the gas supplier.

This is a room sealed appliance and no other ventilation is required than what is provided.

Please contact your Heat & Glo dealer with any questions or concerns. For the number of your nearest Heat & Glo dealer, please visit www.heatnglo.com.

READ THIS MANUAL BEFORE INSTALLING OR OPERATING THIS APPLIANCE. THIS *INSTALLERS GUIDE* MUST BE LEFT WITH APPLIANCE FOR FUTURE REFERENCE.

⚠ WARNING



HOT SURFACES!

Glass and other surfaces are hot during operation AND cool down.

Hot glass will cause burns.

- **DO NOT** touch glass until it is cooled
 - **NEVER** allow children to touch glass
 - Keep children away
 - **CAREFULLY SUPERVISE** children in same room as fireplace.
 - Alert children and adults to hazards of high temperatures.
- High temperatures may ignite clothing or other flammable materials.**
- Keep clothing, furniture, draperies and other flammable materials away.

This appliance has been supplied with an integral barrier to prevent direct contact with the fixed glass panel. DO NOT operate the appliance with the barrier removed.

These instructions are only valid if the following country symbol is on the appliance. If this symbol is not present on the appliance, it is necessary to refer to the technical instructions which will provide the necessary information concerning the modification of the appliance to the conditions of use for the country.

These instructions are valid for the following countries: GB, IE

→ This product may be covered by one or more of the following patents: (United States) 5601073, 5613487, 5647340, 5890485, 5941237, 6006743, 6019099, 6053165, 6145502, 6374822, 6484712, 6601579, 6769426, 6863064, 7077122, 7098269, 7258116, 7470729, 8147240 or other U.S. and foreign patents pending.

SAFETY AND WARNING INFORMATION



READ and **UNDERSTAND** all instructions carefully before starting the installation. **FAILURE TO FOLLOW** these installation instructions may result in a possible fire hazard and will void the warranty.



Prior to the first firing of the fireplace, **READ** the Using Your Fireplace section of the *Users Guide*.



DO NOT USE this appliance if any part has been under water. Immediately **CALL** a qualified service technician to inspect the unit and to replace any part of the control system and any gas control which has been under water.



THIS UNIT IS NOT FOR USE WITH SOLID FUEL.



Installation and repair should be **PERFORMED** by a qualified service person. The appliance and flue system should be **INSPECTED** before initial use and at least annually by a professional service person.



Always **KEEP** the appliance clear and free from combustible materials, petrol, and other flammable vapors and liquids.



NEVER OBSTRUCT the flow of combustion and ventilation air. Keep the front of the appliance **CLEAR** of all obstacles and materials for servicing and proper operations.



Due to the high temperature, the appliance should be **LOCATED** out of traffic areas and away from furniture and draperies. Clothing or flammable material **SHOULD NOT BE PLACED** on or near the appliance.



Children and adults should be **ALERTED** to the hazards of high surface temperature and should **STAY AWAY** to avoid burns or clothing ignition. Young children should be **CAREFULLY SUPERVISED** when they are in the same room as the appliance.



These units **MUST** use one of the fluing systems described in the Installing the Fireplace section of the *Installers Guide*. **NO OTHER** flue systems or components **MAY BE USED**.



This gas appliance and flue assembly **MUST** be vented directly to the outside and **MUST NEVER** be attached to a chimney serving a separate solid fuel burning appliance. Each gas appliance **MUST USE** a separate flue system. Common flue systems are **PROHIBITED**.



INSPECT the external terminal cap on a regular basis to make sure that no debris is interfering with the air flow.



The glass door assembly **MUST** be in place and sealed, and the trim door assembly **MUST** be in place on the appliance before the unit can be placed into safe operation.



DO NOT OPERATE this appliance with the glass door removed, cracked, or broken. Replacement of the glass door should be performed by a licensed or qualified service person. **DO NOT** strike or slam the glass door.



The glass door assembly **SHALL ONLY** be replaced as a complete unit, as supplied by the gas appliance manufacturer. **NO SUBSTITUTE** material may be used.



DO NOT USE abrasive cleaners on the glass door assembly. **DO NOT ATTEMPT** to clean the glass door when it is hot.



Turn off the gas before servicing this appliance. It is recommended that a qualified service technician perform an appliance check-up at the beginning of each heating season.



Any safety screen or guard removed for servicing must be replaced before operating this appliance.



This appliance is intended for use on a gas installation with a governed meter.

Table of Contents

Safety and Warning Information	2
→ Service Parts List	4
Section 1: Approvals and Regulations.....	7
Appliance Certification.....	7
Installation Regulations	7
Section 2: Getting Started	8
Introducing the Heat & Glo Gas Fireplaces	8
Pre-installation Preparation	8
Section 3: Installing the Fireplace	10
Step 1 Locating the Fireplace.....	10
Step 2 Framing the Fireplace	11
Step 3 Installing the Flue System.....	12
A. Flue System Approvals.....	12
B. Flue Pipe Clearances to Combustibles	23
C. Wall Penetration Framing.....	23
D. Vertical Penetration Framing	24
E. Assemble Flue Pipe Sections (DVP Pipe Only)	25
F. Assemble Flue Pipe Sections (SLP Pipe Only).....	26
G. Assemble SLP or DVP Slip Sections	26
H. Securing the Flue Pipe Sections (DVP and SLP Pipe)	27
I. Installing Metal Roof Flashing.....	28
J. Installing Vertical Termination Cap	29
K. Assemble and Install Storm Collar	29
L. Heat Shield Requirements for Horizontal Termination	30
Step 4 Positioning, Leveling and Securing the Fireplace	32
Step 5 The Gas Control Systems.....	32
Step 6 The Gas Supply Line	33
→ Step 7 Gas Pressure Requirements.....	34
Step 8 Wiring the Fireplace	34
Step 9 Finishing.....	35
Step 10 Installing Trim, Logs & Ember Material	36
Installing the Trim.....	36
Positioning the Logs.....	37
Placing the Ember Material.....	39
Step 11 Before Lighting the Fireplace	40
Step 12 Lighting the Fireplace.....	40
After the Installation	40
Section 4: Maintaining and Servicing Your Fireplace.....	41
Section 5: Troubleshooting	43
Limited Lifetime Warranty	46

→ = Contains updated information.

Log Assembly

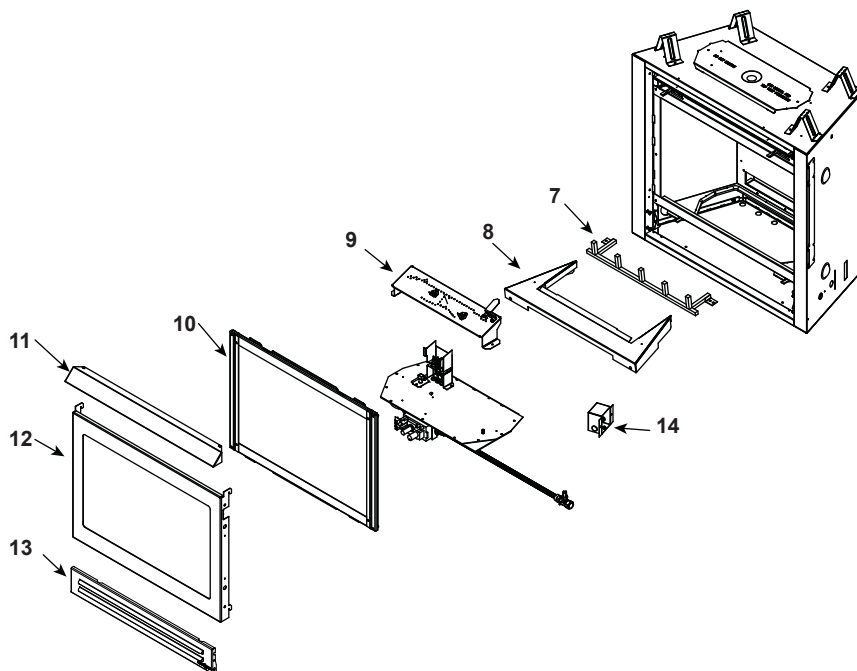

IMPORTANT: THIS IS DATED INFORMATION. When requesting service or replacement parts for your appliance, please provide model number and serial number. All parts listed in this manual may be ordered from an authorized dealer.

ITEM	DESCRIPTION	COMMENTS	PART NUMBER
	Log Set Assembly		LOGS-350CE-D
1	Log 1		SRV327-701
2	Log 2		SRV2033-701
3	Log 3		SRV705-703
4	Log 4		SRV530-716
5	Log 5		SRV438-724
6	Log 6		SRV540-704
7	Grate Assembly		2033-013
8	Base Pan		2033-105
9	Burner N	Pre Sept 2007	2033-007
		Post Sept 2007	2033-027
	Burner P	Pre Sept 2007	2033-008
		Post Sept 2007	2033-028
	Burner B	Pre Sept 2007	2033-009
		Post Sept 2007	2033-029
10	Glass Door Assembly	Pre 0021061383	GLA-350TRS
		Post 0021061383	GLA-3504TRS
11	Hood		SRV540-174
12	Door Assembly	Pre 00295123	540-382A
		Post 00295123	2033-020
13	Door Assembly, Lower	Post 00295123	2033-042
14	Junction Box		546-250A

Additional service part numbers appear on following page.

3/13

#15 Valve Assembly

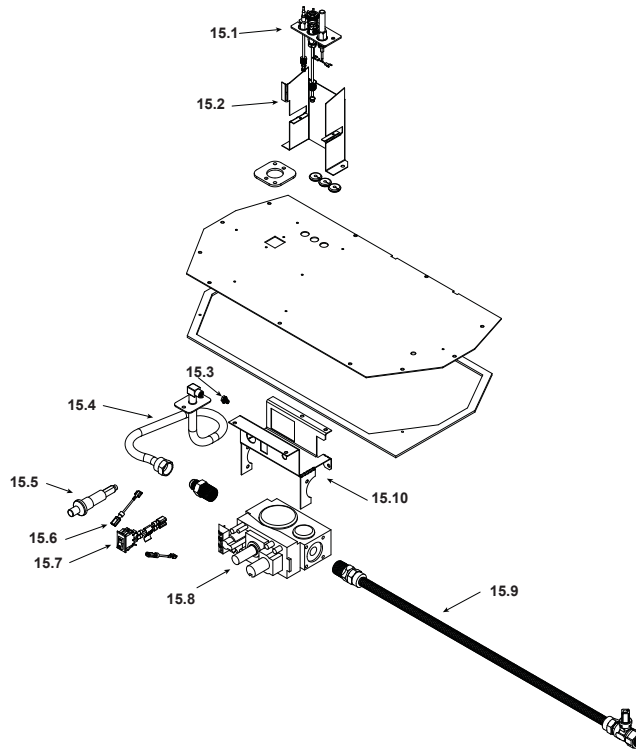

IMPORTANT: THIS IS DATED INFORMATION. When requesting service or replacement parts for your appliance, please provide model number and serial number. All parts listed in this manual may be ordered from an authorized dealer.

ITEM	DESCRIPTION	COMMENTS	PART NUMBER
15.1	Pilot Assembly N	Pre Mar 2013	529-550A
		Post Mar 2013	2033-550
	Pilot Assembly P	Pre Mar 2013	529-551A
		Post Mar 2013	2033-551
15.2	Pilot Bracket	Pre Sept 2007	2033-103
		Post Sept 2007	2033-133
15.3	Orifice N (# 44C)		582-844
	Orifice B (# 56C)		582-856
	Orifice P (# 55C)		582-855
15.4	Flexible Gas Connector		383-302A
15.5	Piezo Ignitor		291-513
15.6	Wire Assembly		049-552A
15.7	On/Off Switch Assembly		060-521A
15.8	Valve N		060-524
	Valve P		060-526
15.9	Flex Ball Valve Assembly		531-320A
15.10	Valve Bracket	No longer available	529-169
		Post Sept 2007	2118-104

Additional service part numbers appear on following page.

1

Approvals and Regulations

Appliance Certification

The Heat & Glo fireplace models discussed in this *Installers Guide* have been tested to certification standards and listed by the applicable laboratories.

MODEL	LABORATORY	TYPE	CERTIFICATION STANDARD
SL-350TRS-CE-D	BSI	Gas Fireplace	BS EN 613:2001 (Amd 1)

Installation Regulations

Before installation check that local distribution conditions, nature of gas and pressure, and adjustment of the appliance are compatible.

This appliance must be installed with the rules in force, and used only in a sufficiently ventilated space. Consult instructions before installation and use of this appliance.

Introducing the Heat & Glo Gas Fireplaces

Pre-installation Preparation

Heat & Glo direct flue gas fireplaces are designed to operate with all combustion air siphoned from outside of the building and all exhaust gases expelled to the outside.

The information contained in this *Installers Guide*, unless noted otherwise, applies to all models and gas control systems.

Gas fireplace diagrams, including the dimensions, are shown in this section.

This gas fireplace and its components are tested and safe when installed in accordance with this *Installers Guide*. Report to your dealer any parts damaged in shipment, particularly the condition of the glass. **Do not install any unit with damaged, incomplete, or substitute parts.**

The flue system components and trim doors are shipped in separate packages. The gas logs are packaged separately and must be field installed.

Read all of the instructions before starting the installation. Follow these instructions carefully during the installation to ensure maximum safety and benefit. Failure to follow these instructions will void the owner's warranty and may present a fire hazard.

The Heat & Glo Fireplace Products, Inc. Warranty will be voided by, and Heat & Glo Fireplace Products, Inc. disclaims any responsibility for, the following actions:

- Installation of any damaged fireplace or flue system component.
- Modification of the fireplace or direct flue system.
- Installation other than as instructed by Heat & Glo Fireplace Products, Inc.
- Improper positioning of the gas logs or the glass door.
- Installation and/or use of any component part not manufactured and approved by Heat & Glo Fireplace Products, Inc., not withstanding any independent testing laboratory or other party approval of such component part or accessory.

ANY SUCH ACTION MAY POSSIBLY CAUSE A FIRE HAZARD.

2

Getting Started

When planning a fireplace installation, it's necessary to determine:

- Where the unit is to be installed.
- The flue system configuration to be used.
- Gas supply piping.
- Electrical wiring.
- Framing and finishing details.
- Whether optional accessories—devices such as a fan, wall switch, or remote control—are desired.

If the fireplace is to be installed on carpeting or tile, or on any combustible material other than wood flooring, the fireplace should be installed on a metal or wood panel that extends the full width and depth of the fireplace.

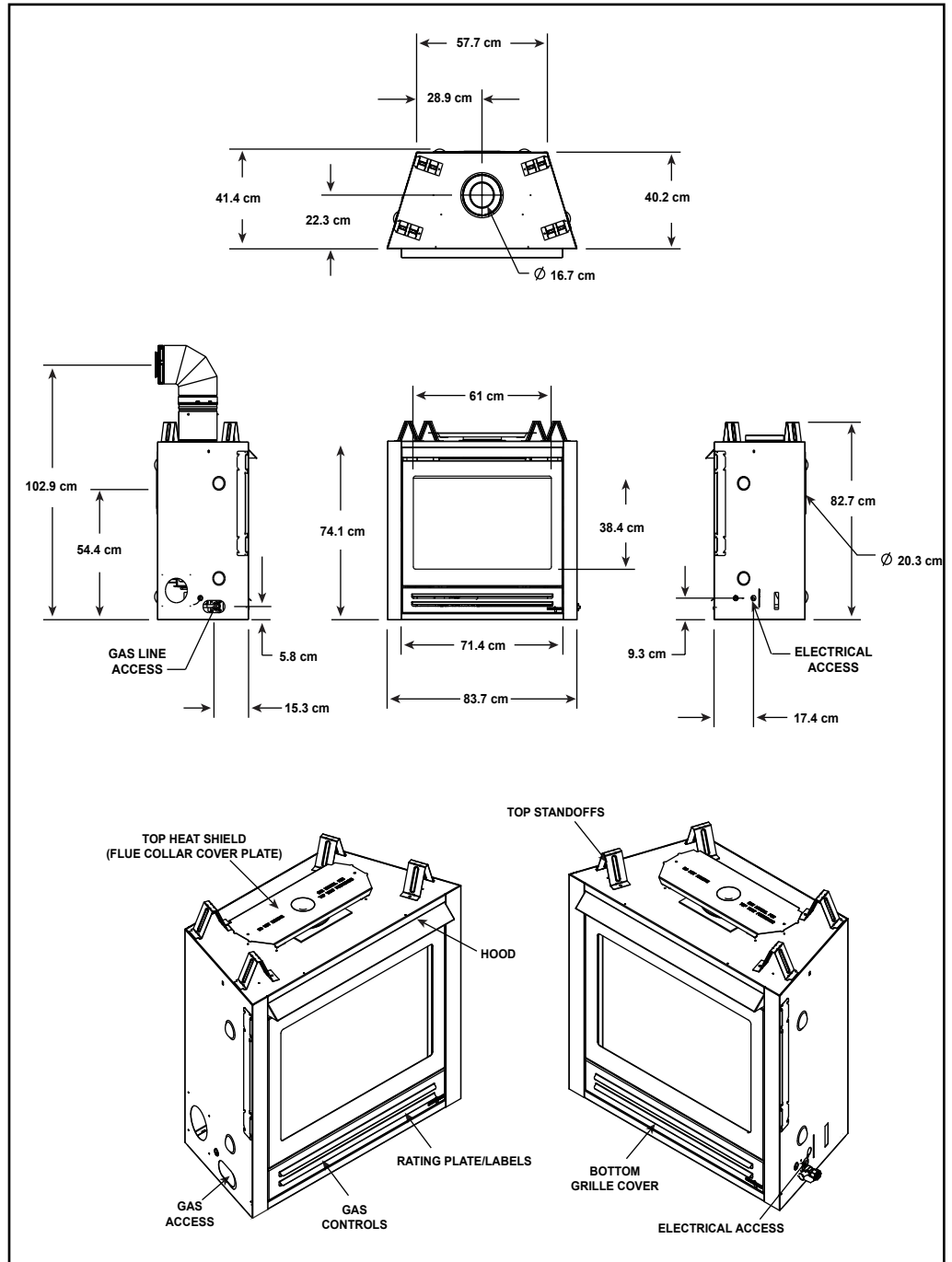

Figure 1. Diagram of the SL-350TRS-CE

Step 1 Locating the Fireplace

The diagram below shows space and clearance requirements for locating a fireplace within a room.

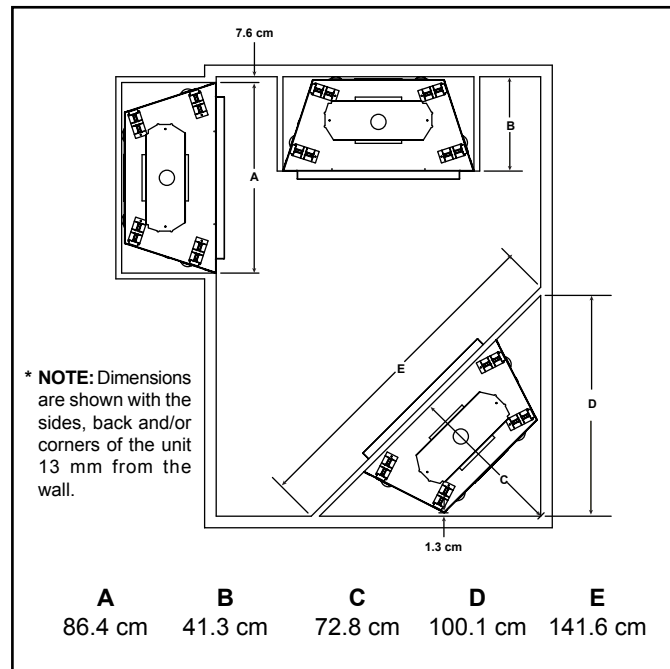

Figure 2. Fireplace Dimensions, Locations, and Space Requirements

Clearance Requirements

The top and back of the fireplace are defined by standoffs.

The heat shield must be attached as shown if combustible materials are placed directly on top standoffs (Figure 3).

The minimum clearance to a perpendicular wall extending past the face of the fireplace is 7.62 cm.

The back of the fireplaces may be recessed into combustible construction, as shown below.

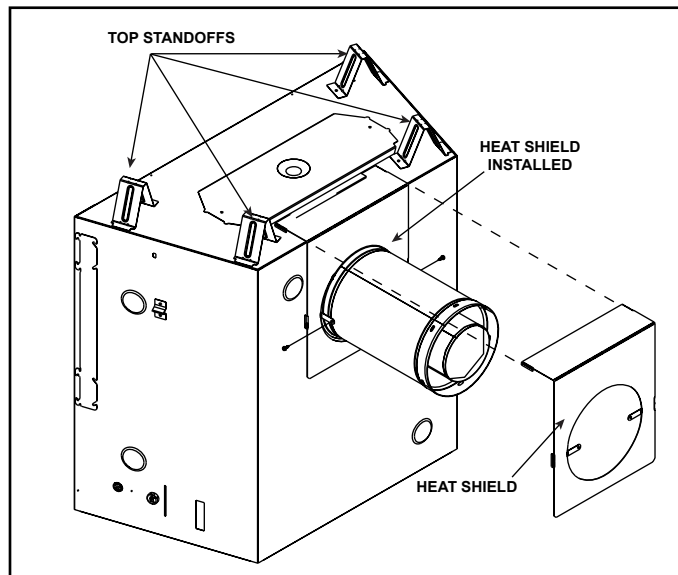

Figure 3. Heat Shield

MODEL: SL-350TRS-CE-D	RECESSED DEPTH: 41.3 cm
------------------------------	--------------------------------

Minimum Clearances from the Fireplace to Combustible Materials					
Glass Front	Floor	Back of Fireplace	Sides of Fireplace	Top of Fireplace	Ceiling
91.4 cm	0	1.3 cm	1.3 cm	8.9 cm	79 cm

3

Installing the Fireplace

Minimum Clearances from the Flue Pipe to Combustible Materials						
For Horizontal Sections			For Vertical Sections	At Wall Firestops		
Top	Bottom	Sides	2.54 cm	Top	Bottom	Sides
7.6 cm	2.54 cm	2.54 cm		6.4 cm	1.3 cm	2.54 cm

Step 2 Framing the Fireplace

Fireplace framing can be built before or after the fireplace is set in place. Framing should be positioned to accommodate wall coverings and fireplace facing material. The diagram below shows framing reference dimensions.

CAUTION

MEASURE FIREPLACE DIMENSIONS, AND VERIFY FRAMING METHODS AND WALL COVERING DETAILS, BEFORE FRAMING CONSTRUCTION BEGINS.

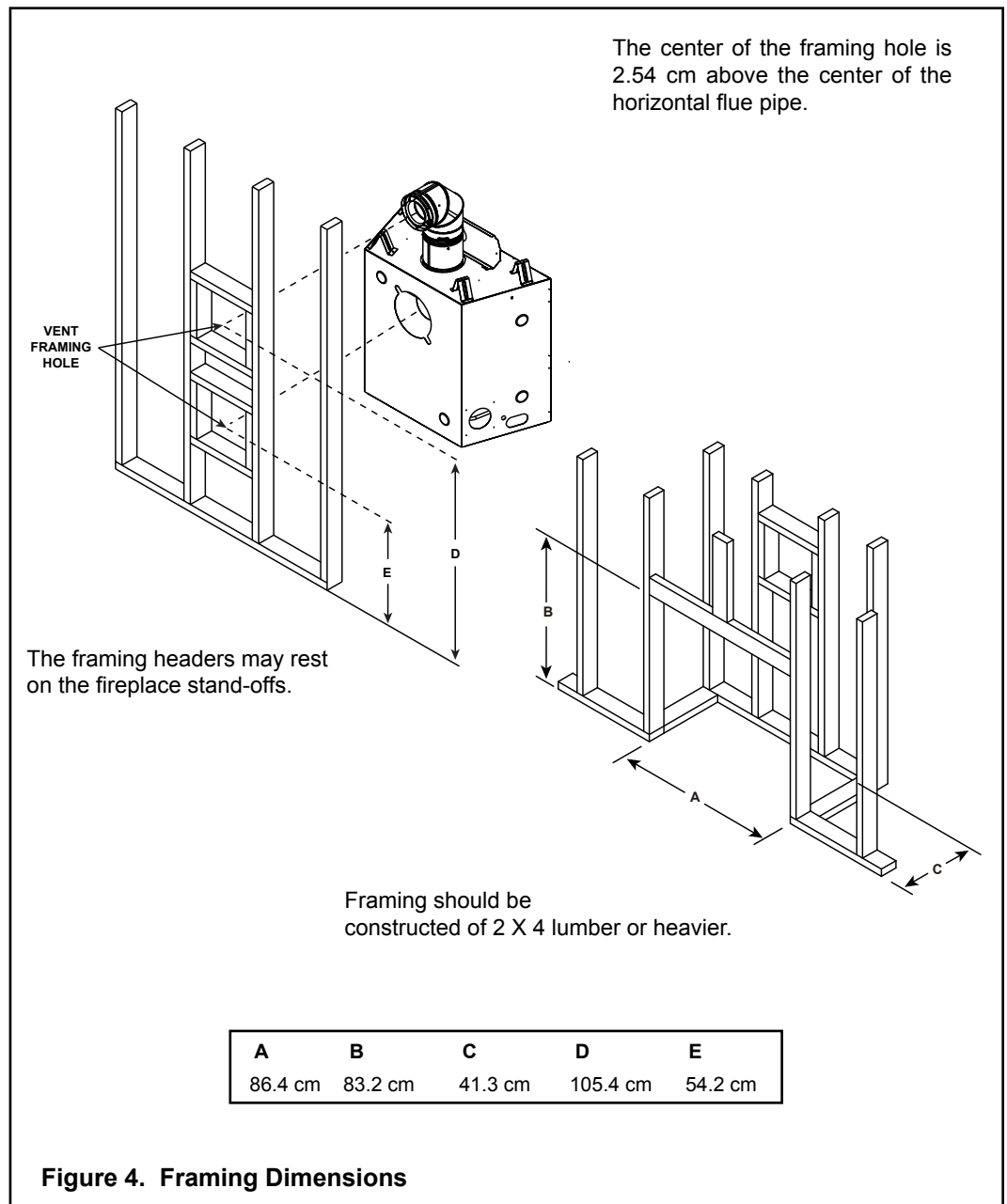

Figure 4. Framing Dimensions

Step 3 Installing the Flue System

A. Flue System Approvals

These models have flue starting collars on both the top and the back of the unit. Depending upon the installation, decide which ONE set of starting collars will be used to attach the flue system. The starting collar sealing cap must remain on the starting collar NOT used.

These models use SLP series, direct flue components when using the **TOP** flue collars and DVP SERIES direct flue components when using the **REAR** flue collars.



WARNING: YOU MUST NOT MIX DVP SERIES AND SLP SERIES COMPONENTS IN ANY FLUE SYSTEM CONFIGURATION.

Approved flue system components are labeled for identification. **NO OTHER FLUEING SYSTEMS OR COMPONENTS MAY BE USED.** Detailed installation instructions are included with each flue termination kit and should be used in conjunction with this *Installers Guide*. Figure 4 shows flue system components and terminations.

Identifying Flue Components

The flue systems installed on this gas fireplace may include one, two, or three 90° elbow assemblies. The relationships of vertical rise to horizontal run in flue configurations using 90° elbows **MUST BE** strictly adhered to. The rise to run relationships are shown in the flueing drawings and tables on the next several pages.

NOTE: Two 45° elbows may be used in place of one 90° elbow. You **MUST** always maintain the **MAXIMUM** and **MINIMUM** rise-to-run ratios in the flue system when using 45° elbows.

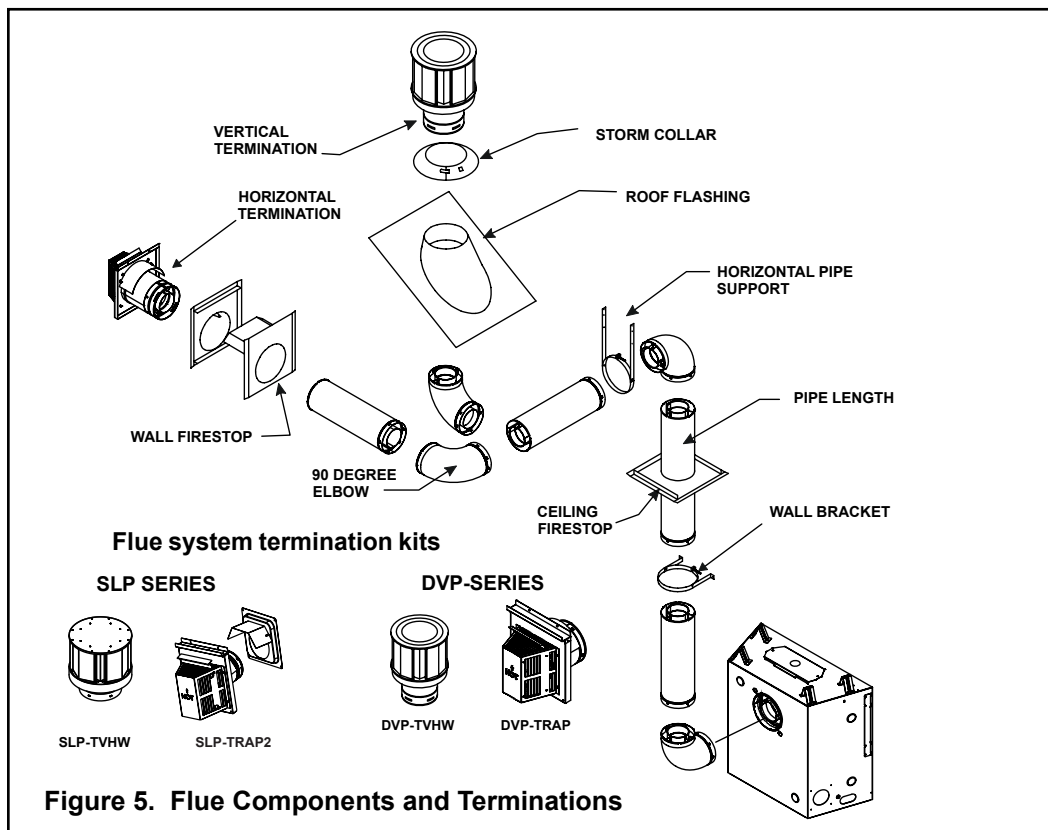

Figure 5. Flue Components and Terminations

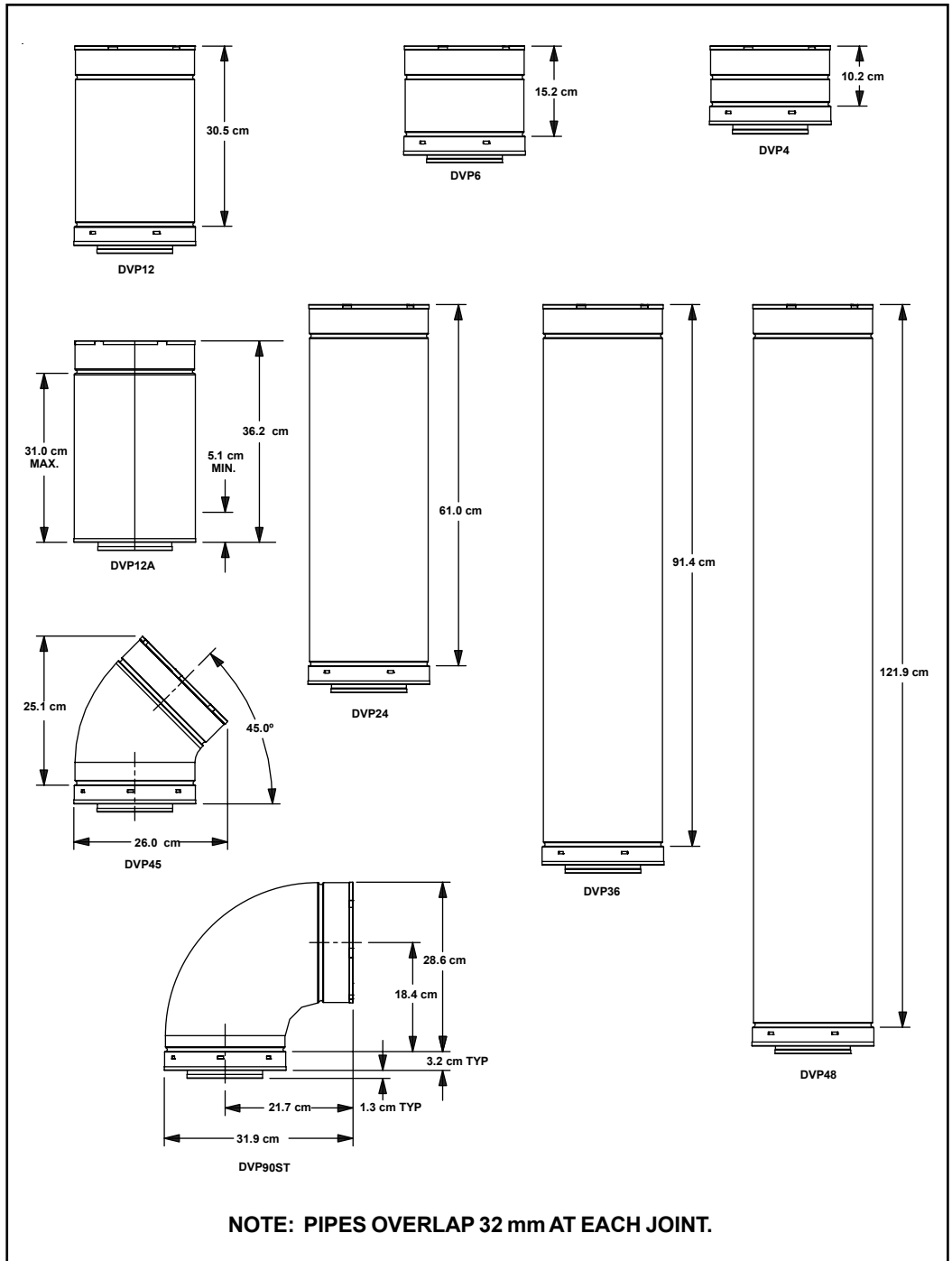

Figure 6. DVP SERIES Balanced Flue Component Specifications (12.7 cm inner flue pipe / 20.3 cm outer flue pipe)

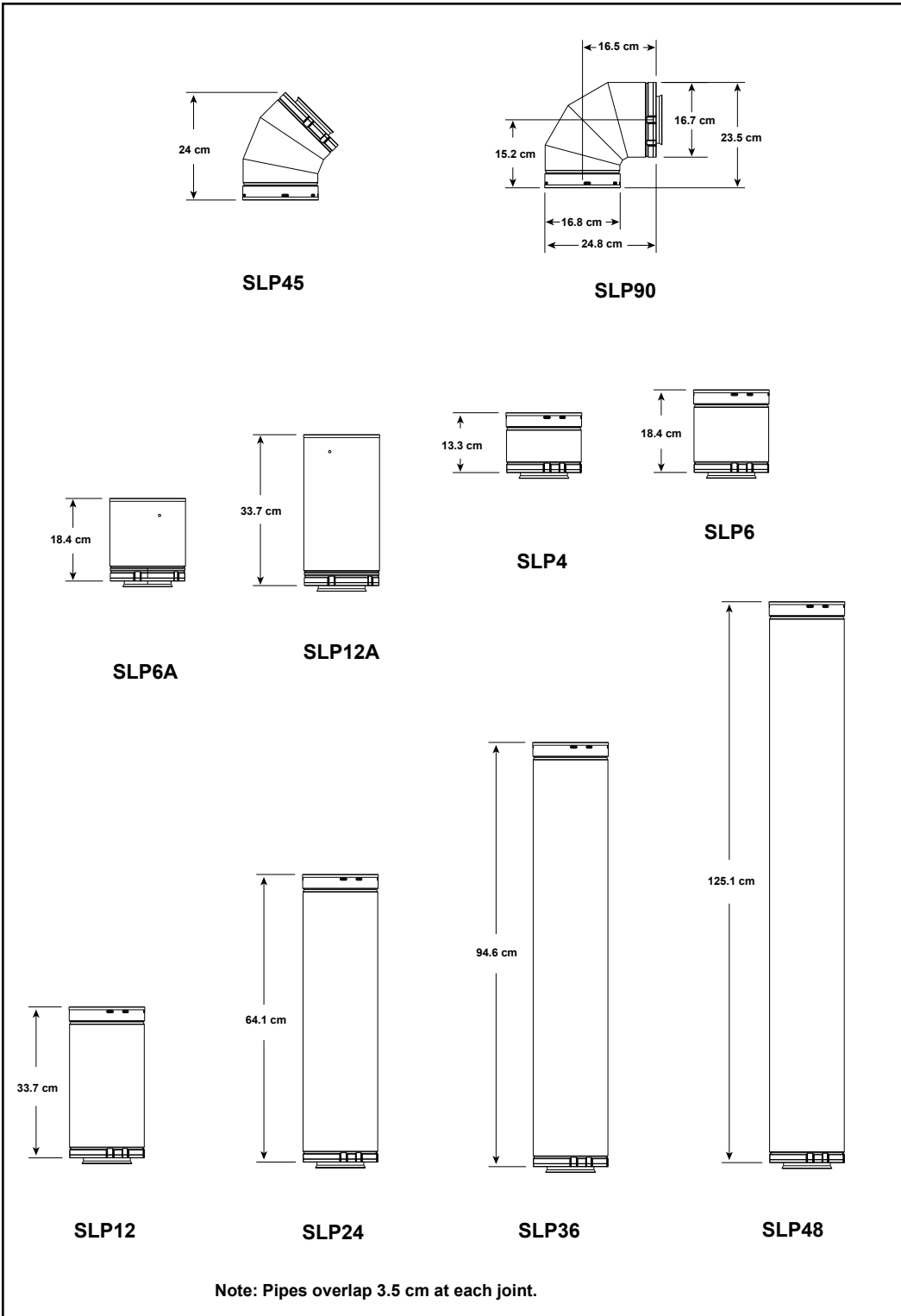

Figure 7. SLP Series Flue Component Specifications (10.2 cm inner flue pipe/16.8 cm outer flue pipe)

**STRAIGHT UP
VERTICAL FLUE**

V
11.8 m MAX.

**USE SLP SERIES
COMPONENTS ONLY.**

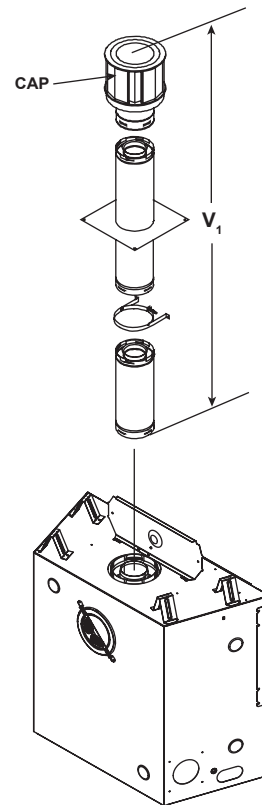

Figure 8. Straight up Vertical Flue

**STRAIGHT OUT HORIZONTAL
FLUE**

H
Max. Run
61 cm

**USE DVP SERIES
COMPONENTS ONLY.**

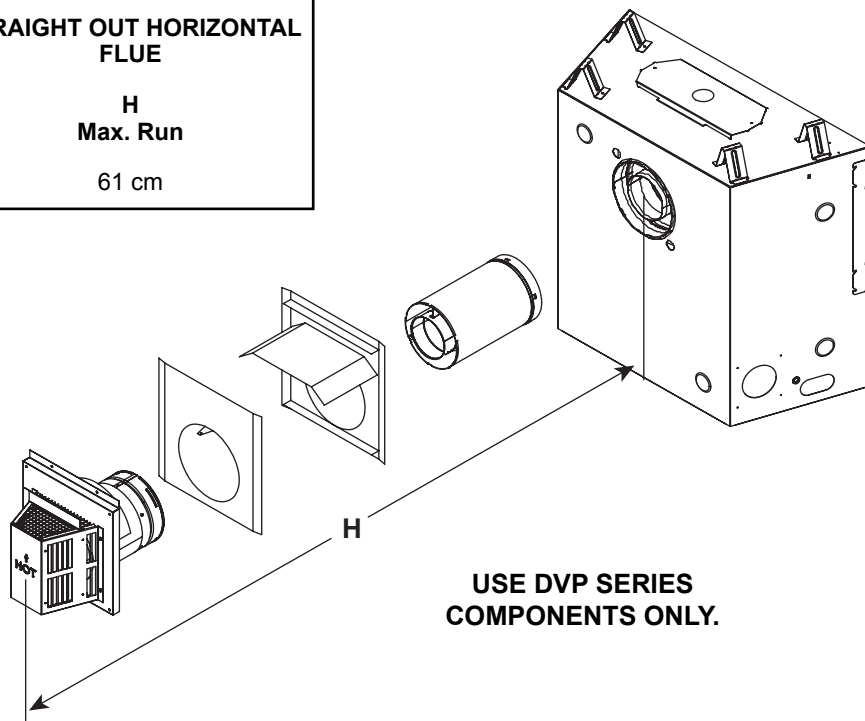
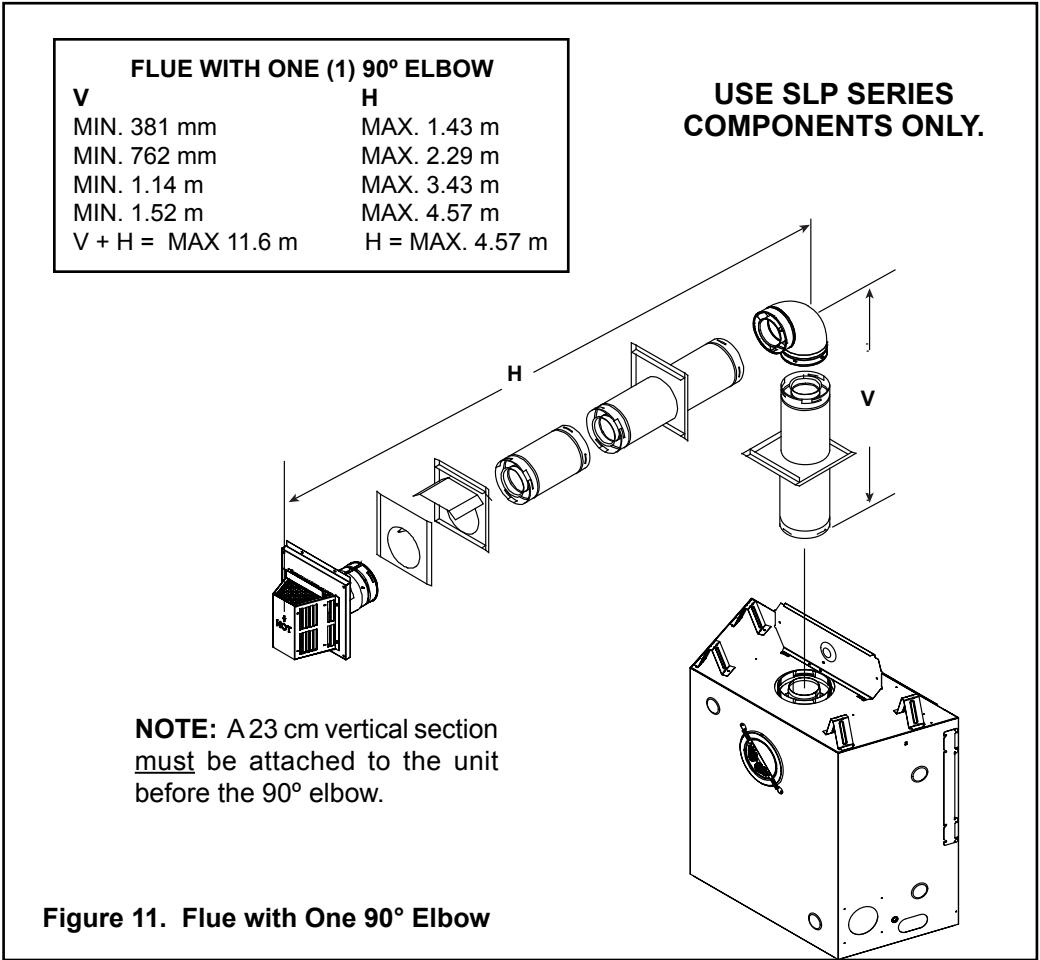
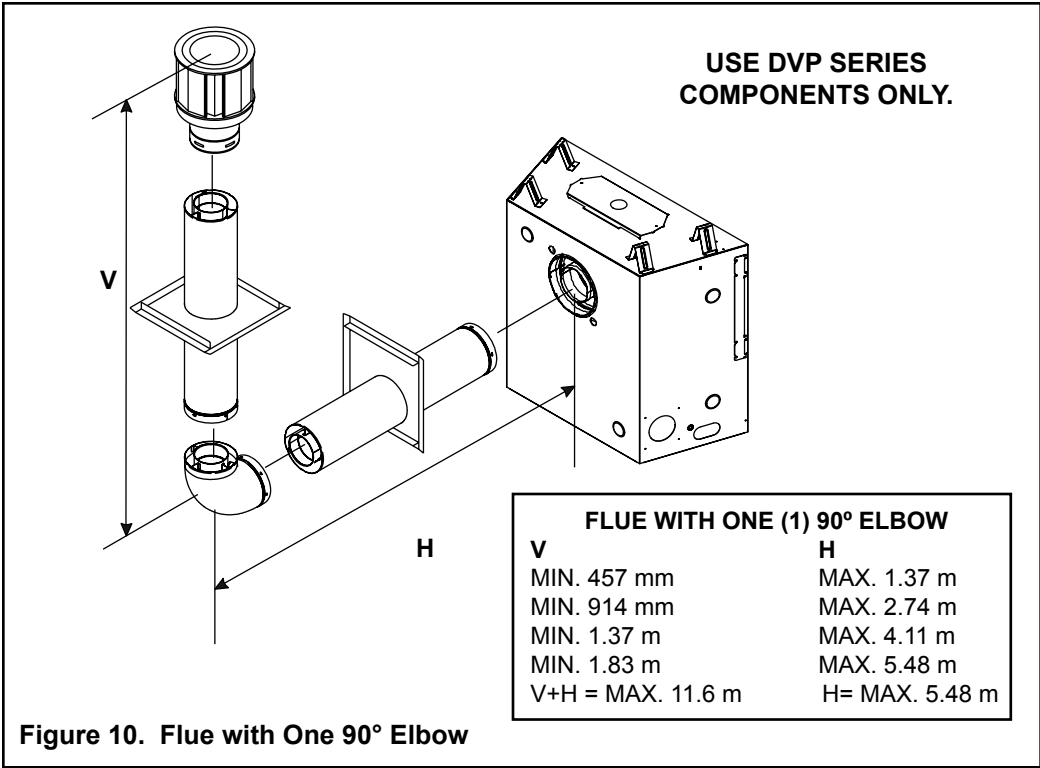
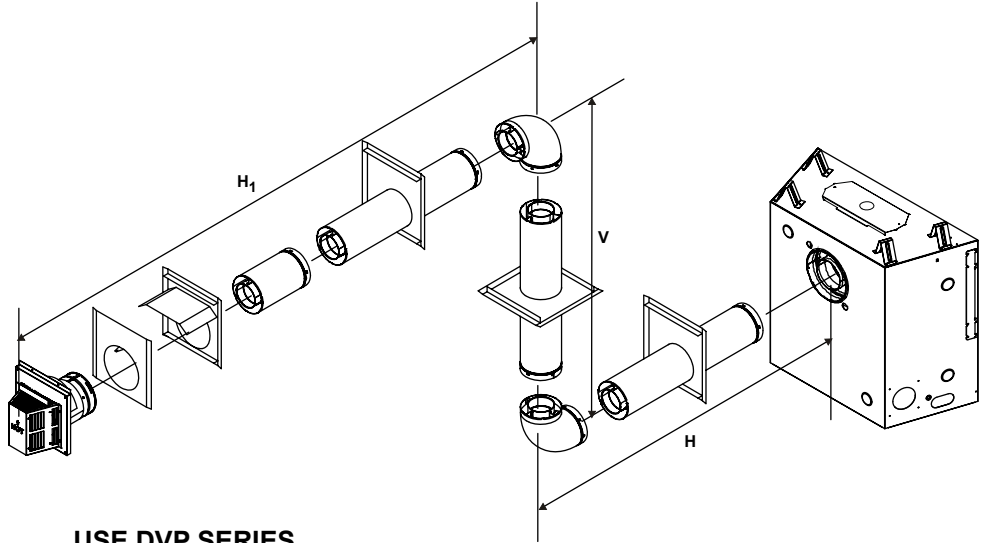

Figure 9. Straight Out Horizontal Flue



FLUE WITH TWO (2) 90° ELBOWS

V	H	H + H₁
MIN. 305 mm	MAX. 610 mm	MAX. 1.22 m
MIN. 610 mm	MAX. 1.22 m	MAX. 2.4 m
MIN. 914 mm	MAX. 1.86 m	MAX. 3.6 m
MIN. 1.22 m	MAX. 2.48 m	MAX. 4.8 m
H = MAX. 2.48 m		H + H ₁ = MAX. 4.8 m
V + H + H ₁ = 11.6 m MAX.		



USE DVP SERIES COMPONENTS ONLY.

FLUE WITH TWO (2) 90° ELBOWS

V	H + H₁
MIN. 305 mm	MAX. 610 mm
MIN. 610 mm	MAX. 1.22 m
MIN. 914 mm	MAX. 1.86 m
MIN. 1.22 m	MAX. 2.48 m
H + H ₁ = MAX. 2.48 m	
V + H + H ₁ = 11.6 m MAX.	

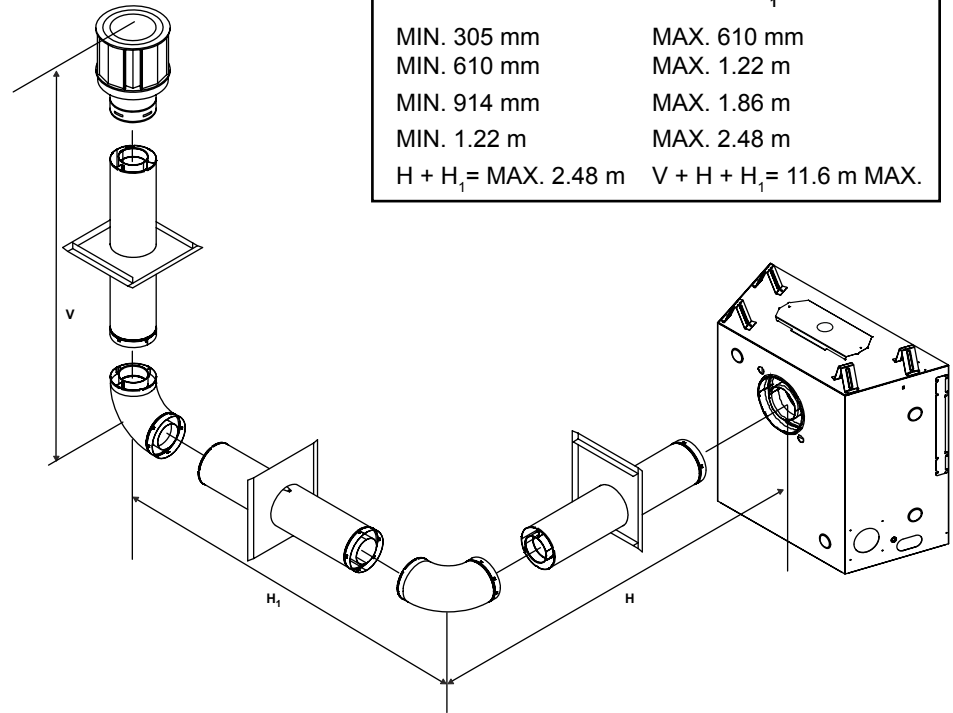

Figure 12. Flue with Two 90° Elbows

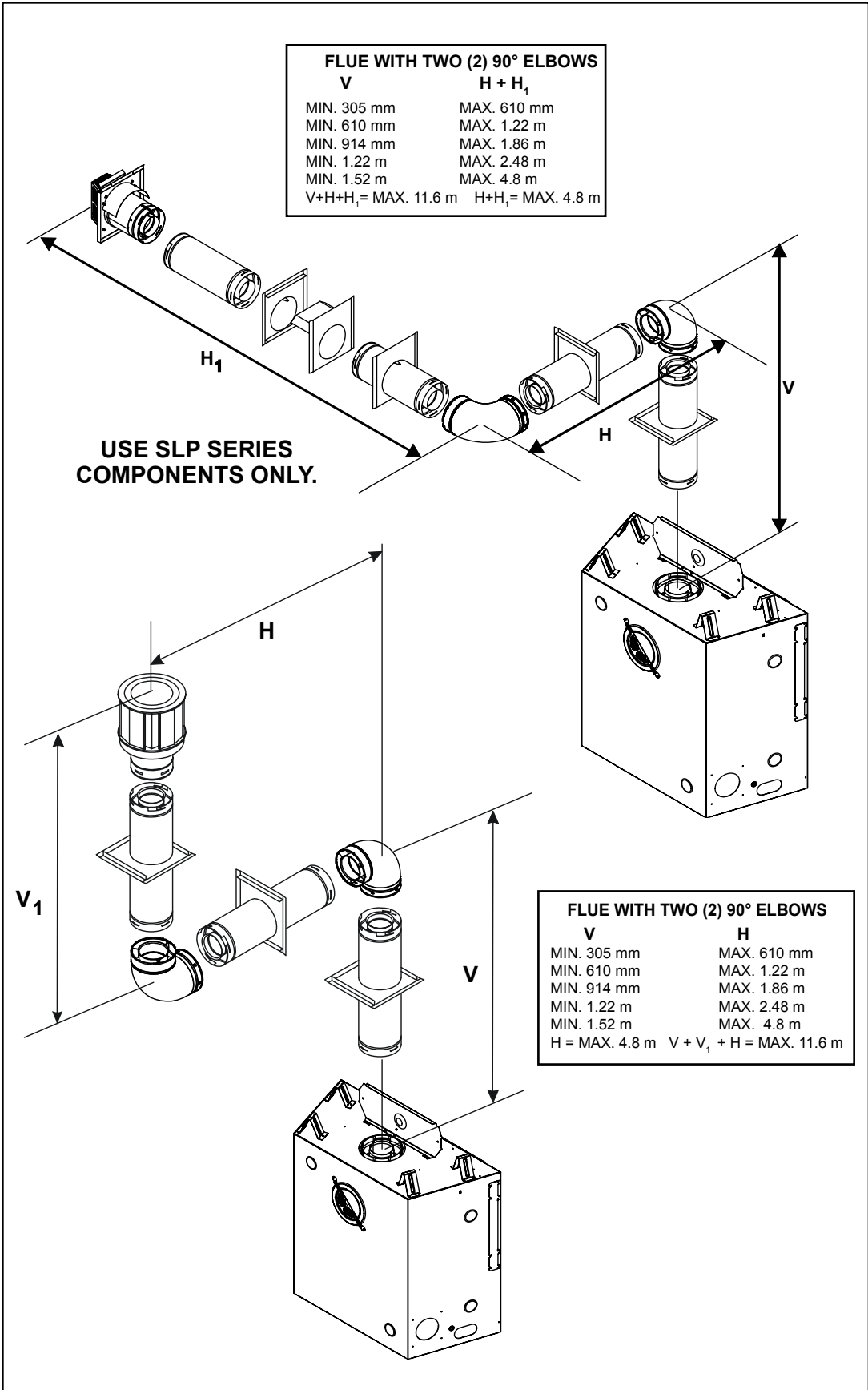

Figure 13. Flue with Two 90° Elbows

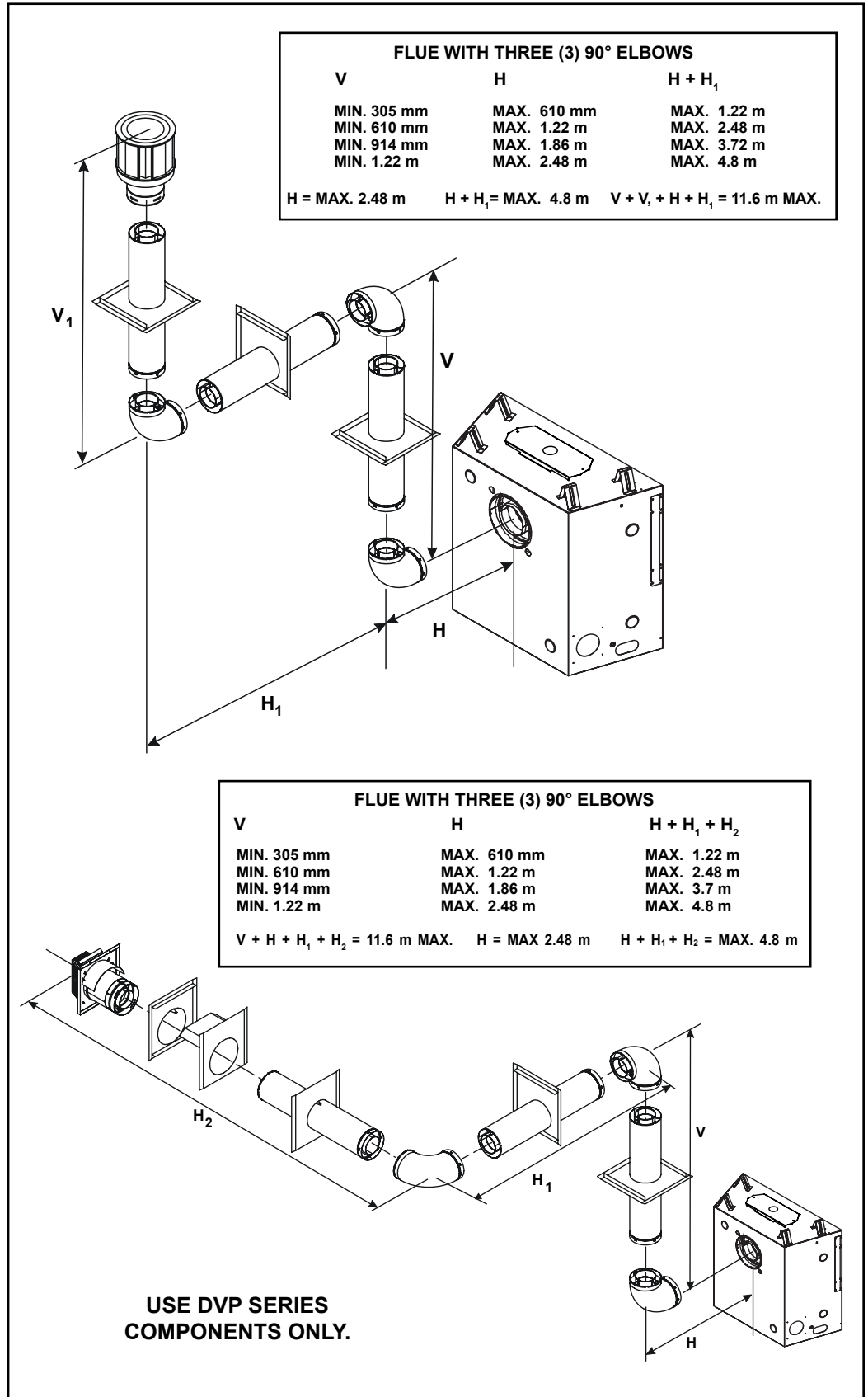

Figure 14. Flue with three 90° elbows

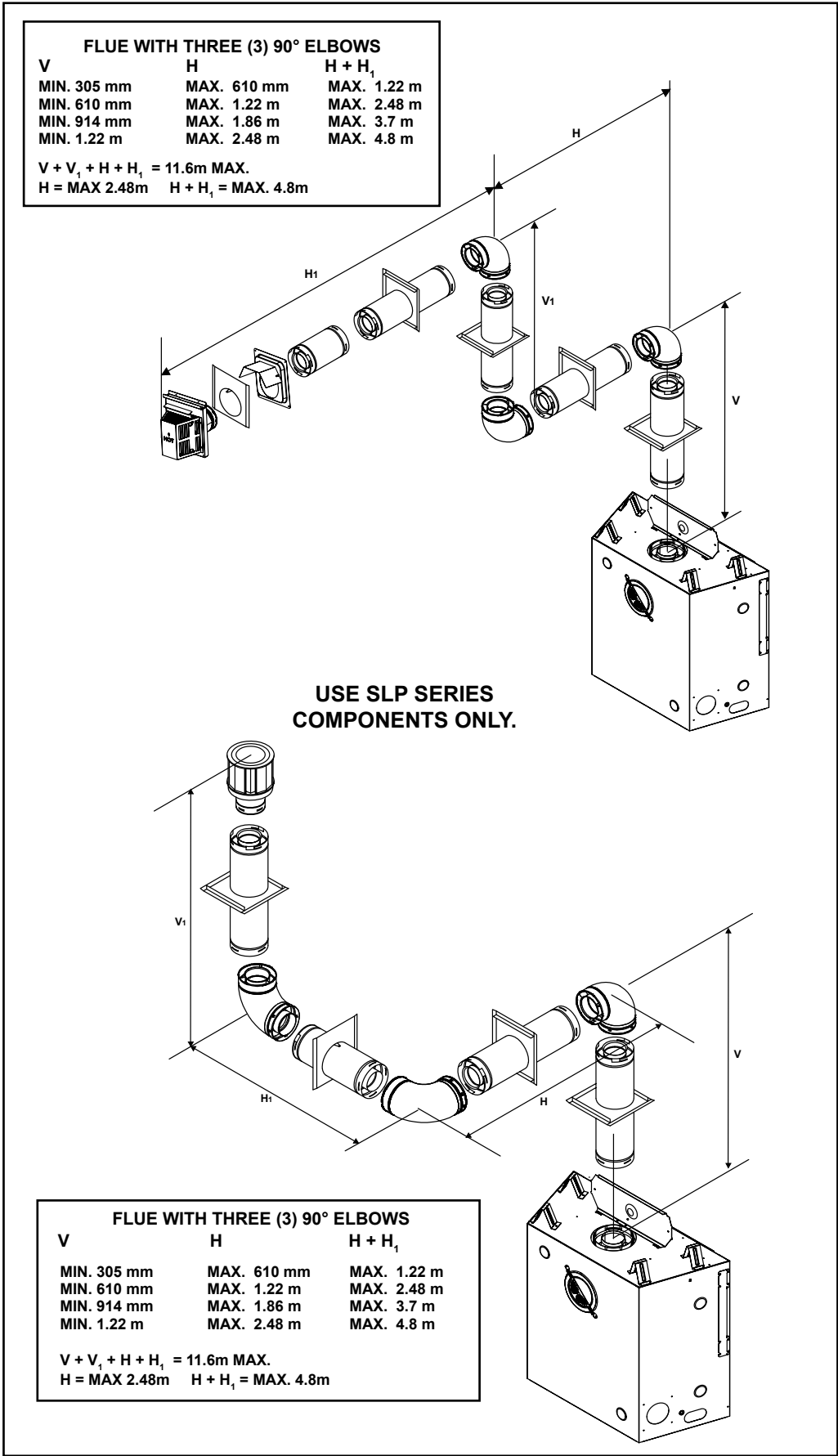

Figure 15. Flue with three 90° elbows

Appliance Preparation

After determining which set of starting collars will be used (top or rear), follow flueing instructions accordingly.

⚠ WARNING: FAILURE TO REMOVE INSULATION IN THE SET OF COLLARS YOU ARE USING COULD CAUSE A FIRE.

⚠ WARNING: YOU MUST LEAVE THE INSULATION AND FLUE CAP IN PLACE IN THE SET OF COLLARS YOU ARE NOT USING.

⚠ WARNING: FIRE RISK ONCE APPLIANCE IS SETUP FOR TOP OR REAR FLUEING, IT CANNOT BE CHANGED AT A LATER TIME. IF FLUE CAP AND COMPONENTS PREVIOUSLY REMOVED ARE IMPROPERLY REINSTALLED, A FIRE MAY RESULT.

CAUTION

Sharp edges-Wear protective gloves and safety glasses during installation.

Top Flue



Figure 16. For top flue, remove the two screws holding the top heat shield in place. For rear flue, see next page.

⚠ WARNING: FIRE RISK DO NOT REMOVE HEAT SHIELD. ELEVATED HEADER TEMPERATURES MAY CAUSE A FIRE.



Figure 17. Rotate the top heat shield to the vertical position as shown above. The heat shield must remain in the vertical position.

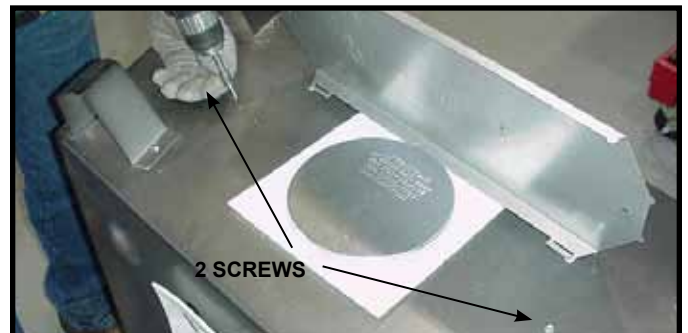

Figure 18. Replace the two screws as shown.



Figure 19. Remove the flue cap.



Figure 20. Remove the insulation basket and white insulation from the center flue pipe.



Figure 21. Remove the insulation from the outer flue pipe.



Figure 22. To attach the first section of flue pipe, make sure to use the fiberglass gasket to seal between the first flue pipe component and the outer fireplace wrap. Use 2 self tapping screws to secure the gasket to the outer wrap.

Note: Once the flue cap has been removed, it cannot be reattached.

Rear Flue



Figure 23. Remove the insulation from the outer flue pipe.



Figure 24. Cut the metal retaining band and fold the sides out.



Figure 25. Fold the center parts of the retaining band out and use to remove the flue cap.



Figure 26. Discard the flue cap, remove and discard the insulation basket. Note: Once the flue cap has been removed it CANNOT be reattached.



Figure 27. Attach the first flue section (it will snap into place). Slide the insulation gasket onto the flue section, up against the appliance and over the tabs. Use two self-tapping screws to secure gasket to outer wrap.

B. Flue Pipe Clearances to Combustibles

WARNING

Fire Risk.
Explosion Risk.

Maintain flue pipe clearance to combustibles as specified.

- Do not pack air space with insulation or other materials.

Failure to keep insulation or other materials away from flue pipe may cause fire.

Note: Heat shields MUST overlap by a minimum of 4 cm.

- DVP heat shield** - designed to be used on a wall 10.2 cm to 18.4 cm thick.
- If wall thickness is less than 10 cm, the existing heat shields must be field trimmed. If wall thickness is greater than 18.4 cm, a DVP-HSM-B will be required.
- SLP heat shield** - designed to be used on a wall 11.1 cm to 19.4 cm thick.
- If wall thickness is less than 11.1 cm, the existing heat shields must be field trimmed. If wall thickness is greater than 19.4 cm, a DVP-HSM-B will be required.

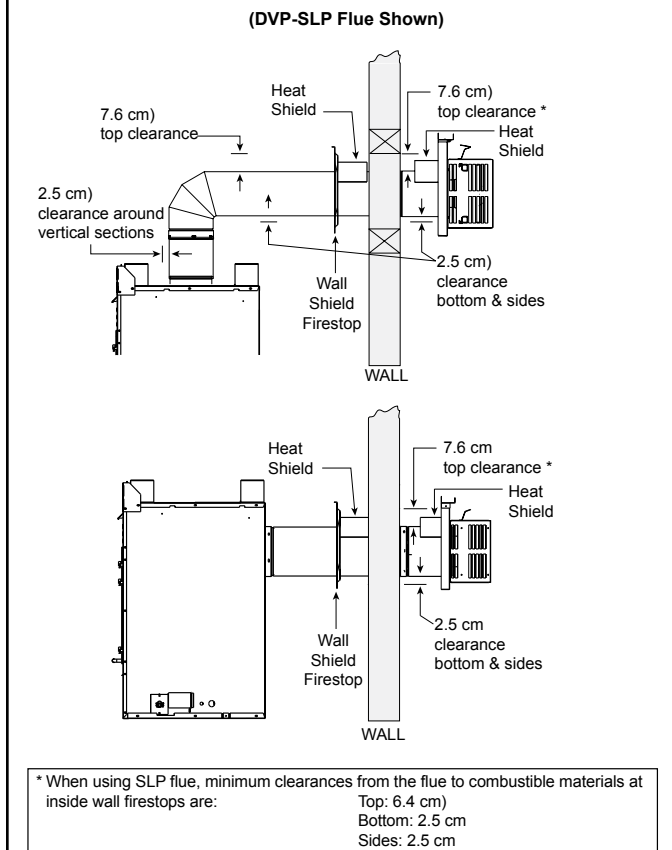

Figure 28 Horizontal Venting Clearances To Combustible Materials

C. Wall Penetration Framing

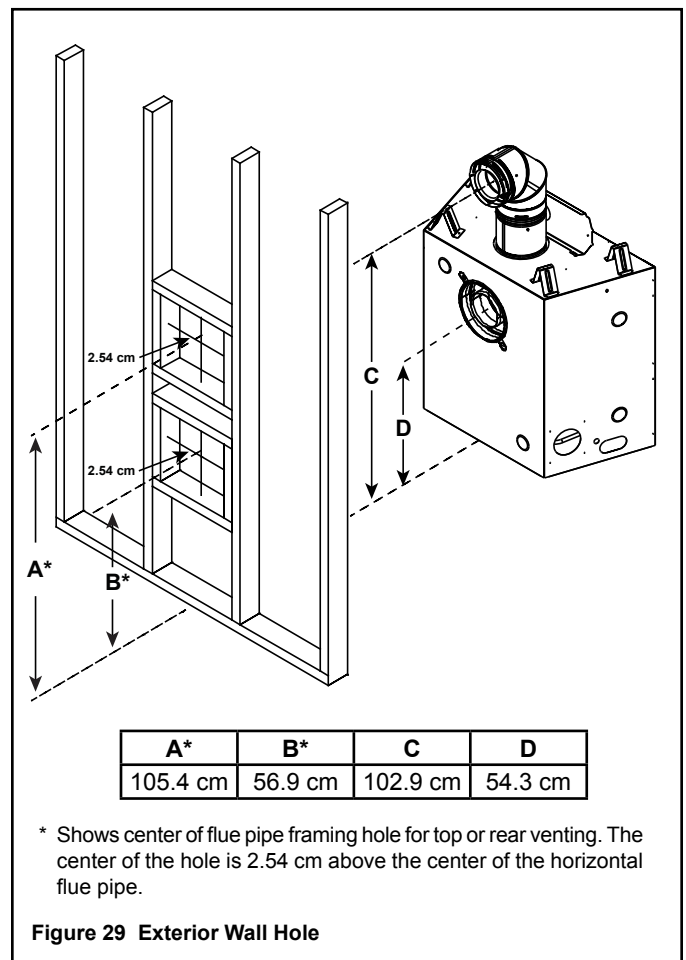

Figure 29 Exterior Wall Hole

Combustible Wall Penetration

Frame a hole in a combustible wall for interior and exterior wall shield firestops, (Figure 29) whenever a wall is penetrated. Use same size framing materials as those used in the wall construction. The wall shield firestops maintain minimum clearances and prevent cold air infiltration.

Note: When penetrating a combustible wall, both interior and exterior wall shield firestops are required.

Non-Combustible Wall Penetration

If the hole being penetrated is surrounded by noncombustible materials such as concrete, a hole with diameter 2.5 cm greater than the pipe is acceptable.

Whenever a non-combustible wall is penetrated, the wall shield firestop is only required on one side and no heat shield is necessary.

If your local inspector requires the wall shield firestop on both sides, then both wall shield firestops must have a heat shield attached to them.

D. Vertical Penetration Framing

WARNING

Fire Hazard

Keep loose materials or blown insulation from touching the flue pipe.

- Hearth & Home Technologies requires the use of an attic shield.

Installing the Ceiling Firestop

- Frame an opening 22.9 cm by 22.9 cm whenever the system penetrates a ceiling/floor (see Figure 30). A steeply slanted roof may require an enlarged opening size in order to maintain proper flue pipe clearances.
- Frame the area with the same sized lumber as used in ceiling/floor joist.
- The ceiling firestop may be installed above or below the ceiling joists when installed with an attic insulation shield. It must be under joists between floors that are not insulated. See Figure 31.
- Secure with 3 fasteners on each side. See Figure 31.
- Do not pack insulation around the flue. Insulation must be kept away from the pipe.

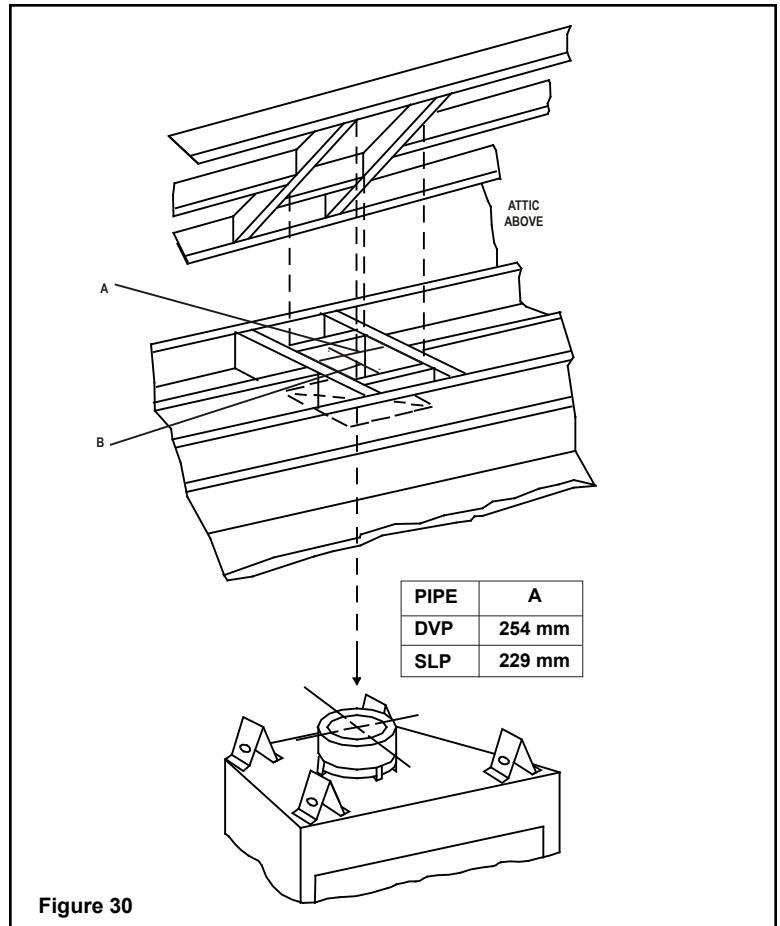

Figure 30

Installing Attic Shield

- Remove one shield from box.

NOTICE: Cut previously installed batt insulation to make room for the attic insulation shield.

- Wrap shield around pipe if pipe is already installed in area to be insulated.
- Match the three holes in each side and fasten with three screws to form a tube.
- Bend three tabs on the bottom of the shield outward to allow attachment to the ceiling firestop.
- Bend the remaining bottom tabs inward 90° to maintain the air space between the pipe and the shield. Set the shield on the ceiling firestop and attach to the firestop.
- Bend all tabs inward 90° around the top of the shield. These tabs must be used to prevent blown insulation from getting between the shield and flue pipe, and to maintain air space clearance.

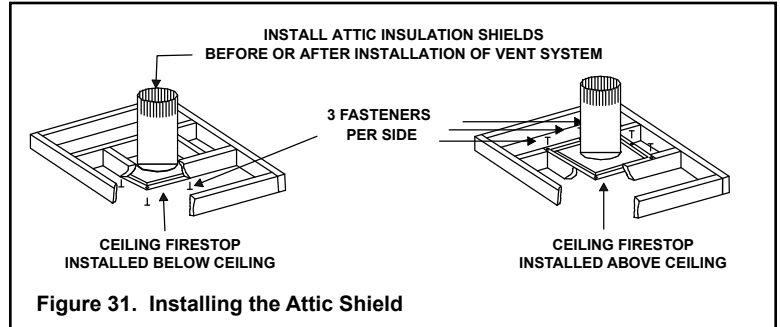

Figure 31. Installing the Attic Shield

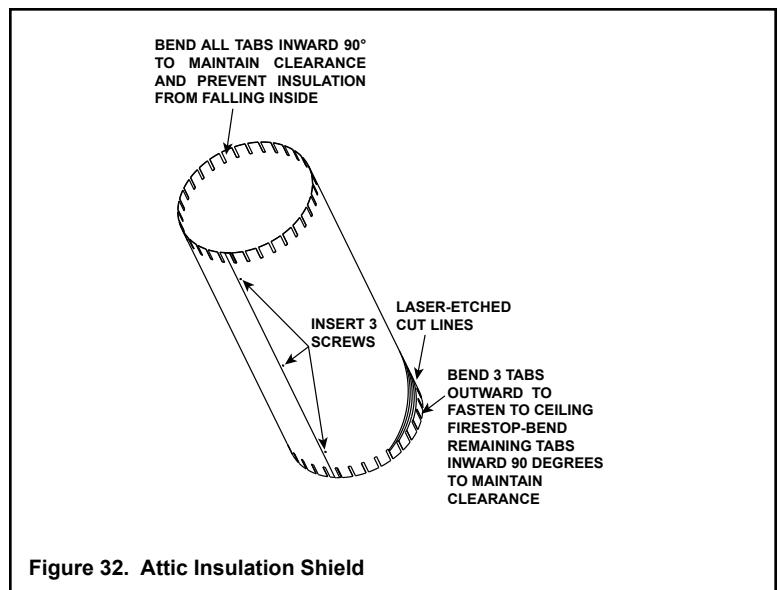

Figure 32. Attic Insulation Shield

E. Assemble Flue Pipe Sections (DVP Pipe Only)

Attach Flue Pipe to the Firebox Assembly

Note: The end of the pipe sections with the lanced tabs will face toward the appliance.

Attach the first pipe section to the starting collar:

- Lanced pipe end of the starting collar
- Inner pipe over inner collar
- Push the pipe section until all lanced tabs snap in place
- Lightly tug on pipe to confirm it has locked.

Commercial, Multi-family (Multi-level exceeding two stories), or High-Rise Applications

All outer pipe joints must be sealed with high temperature silicone (with a minimum of 149 °C continuous exposure rating), including the slip section that connects directly to the horizontal termination cap.

- Apply a bead of silicone sealant inside the female outer pipe joint prior to joining sections. See Figure 33
- Only outer pipes need to be sealed. All unit collar, pipe, slip section, elbow and cap outer flues shall be sealed in this manner, unless otherwise stated.

WARNING! Risk of Fire or Explosion! DO NOT break silicone seals on slip sections. Use care when removing termination cap from slip pipe. If slip section seals are broken during removal of the termination cap, flue pipe may leak.

Assemble Pipe Sections (DVP Pipe Only)

Per Figure 34:

- Start the inner pipe on the lanced end of section A into the flared end of section B.
- Start the outer pipe of section A over the outer pipe of section B.
- Once both vents sections are started, push firmly until all lanced tabs lock into place.
- Lightly tug on the pipe to confirm the tabs have locked.

It is acceptable to use screws no longer than 13 mm to hold outer pipe sections together. If predrilling holes, **DO NOT** penetrate inner pipe.

For 90° and 45° elbows that are changing the flue pipe direction from horizontal to vertical, one screw minimum should be put in the outer flue at the horizontal elbow joint to prevent the elbow from rotating. Use screws no longer than 13 mm. If predrilling screw holes, **DO NOT** penetrate inner pipe.



Figure 33 High Temperature Silicone Sealant

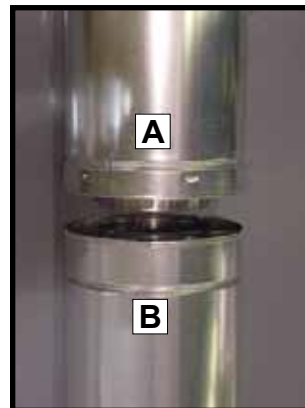

Figure 34



Figure 35

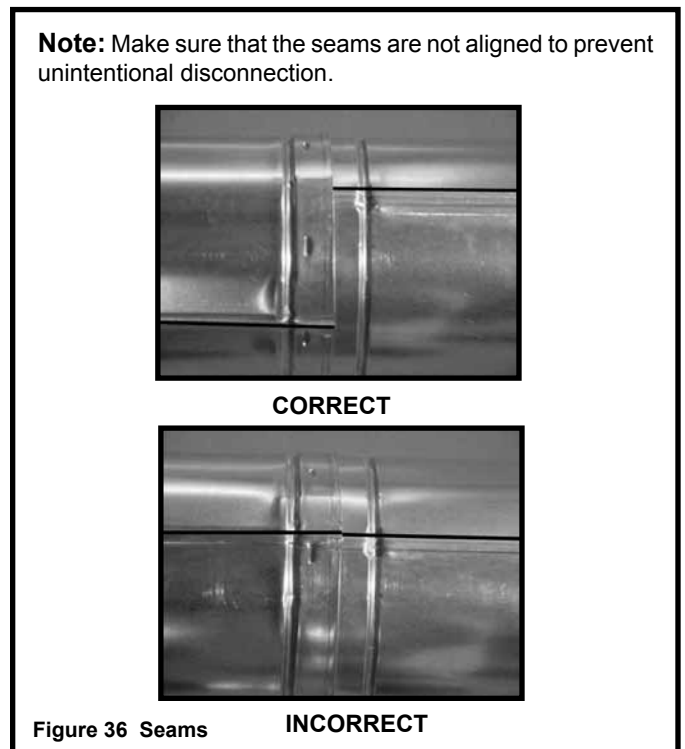

Figure 36 Seams

F. Assemble Flue pipe Sections (SLP Pipe Only)

To attach the first flue pipe component to the starting collars of the appliance:

- Lock the flue pipe components into place by sliding the pipe section onto the collar.
- Align the seam of the pipe and seam of collar to allow engagement. Rotate the flue pipe component to lock into place. Use this procedure for all flue pipe components. See Figure 37.
- Slide the gasket over the first flue pipe section and place it flush to the appliance. This will prevent cold air infiltration. High temperature caulk (with a minimum of 149 °C continuous exposure rating). may be used to hold the part in place.
- Continue adding flue pipe components, locking each succeeding component into place.
- Ensure that each succeeding flue pipe component is securely fitted and locked into the preceding component.

Commercial, Multi-family (Multi-level exceeding two stories), or High-Rise Applications

For Installation into a commercial, multi-family (multi-level exceeding two stories) or high-rise applications: All outer pipe joints must be sealed with high temperature (with a minimum of 149 °C continuous exposure rating) silicone, including the slip section that connects directly to the horizontal termination cap.

- Apply a bead of silicone sealant inside the female outer pipe joint prior to joining sections. See Figure 33.
- Only outer pipes need to be sealed. All unit collar, pipe, slip section, elbow and cap outer flues shall be sealed in this manner, unless otherwise stated.

WARNING! Risk of Fire or Explosion! DO NOT break silicone seals on slip sections. Use care when removing termination cap from slip pipe. If slip section seals are broken during removal of the termination cap, flue pipe may leak.

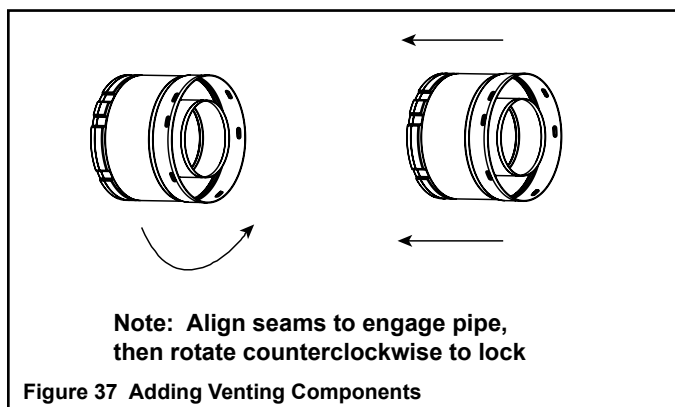

G. Assemble SLP or DVP Slip Sections

- Slide the inner flue of the slip section into the inner flue of the pipe section and the outer flue of the slip section over the outer flue of the pipe section. See Figure 38.
- Slide together to the desired length.

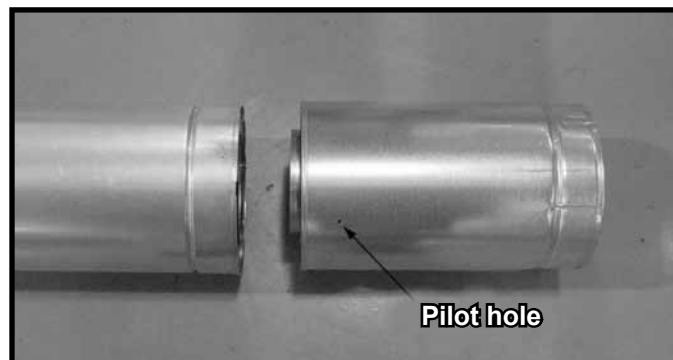

Figure 38 Slip Section Pilot Holes

- Maintain a 4 cm overlap between the slip section and the pipe section.
- Secure the pipe and slip section with two screws no longer than 13 mm, using the pilot holes in the slip section. See Figure 39.

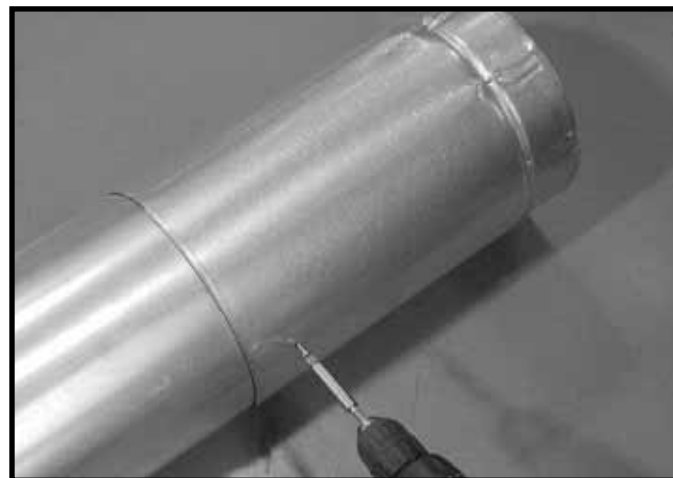

Figure 39 Screws into Slip Section

- Continue adding pipe as necessary following instructions in "Assembling Pipe Sections."

NOTICE: If slip section is too long, the inner and outer flues of the slip section can be cut to the desired length.

NOTICE: When installing a flue pipe system with an HRC termination cap, all pipe system joints shall be sealed using a high temperature (with a minimum of 149 °C continuous exposure rating) silicone sealant.

- Apply a bead of silicone sealant inside the female outer pipe joint prior to joining sections.
- Only outer pipes are sealed, sealing the inner flue is not required.
- All unit collar, pipe, slip section, elbow and cap outer flues shall be sealed.

H. Securing the Flue Pipe Sections (DVP and SLP Pipe)

- Vertical runs of DVP pipe must be supported every 2.44 m after the 7.62 m maximum unsupported rise.
- Vertical runs of SLP pipe must be supported every 2.44 m.
- Horizontal sections must be supported every 1.52 m.
- Flue pipe supports or plumbers strap (spaced 120° apart) may be used to support. See figures 40 and 41.
- Wall shield firestops may be used to provide horizontal support.
- SLP ceiling firestops have tabs that may be used to provide vertical support.

WARNING! Risk of Fire, Explosion or Asphyxiation!
Improper support may allow flue pipe to sag and separate. Use flue pipe run supports and connect flue pipe sections per installation instructions. DO NOT allow flue pipe to sag below connection point to appliance.

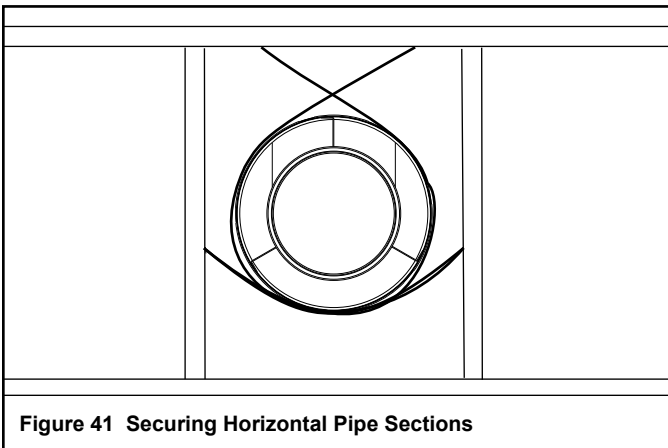
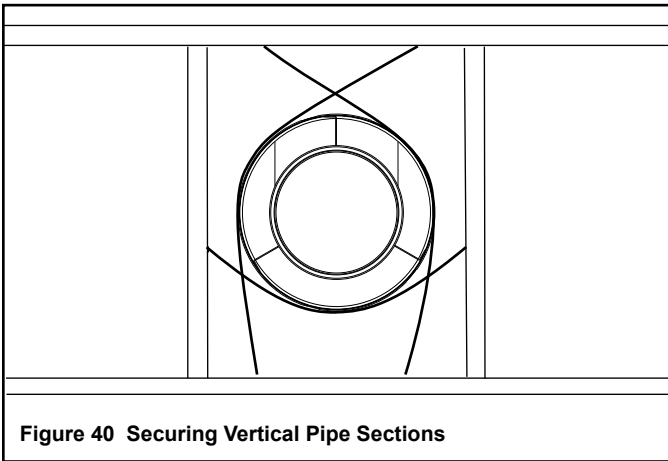

I. Installing Metal Roof Flashing

- See minimum flue pipe heights for various pitched roofs (Figure 42) to determine the length of pipe to extend through the roof.
- Slide the roof flashing over the pipe sections extending through the roof as shown in Figure 43.

NOTICE: Failure to properly caulk the roof flashing could cause water entry.

- Caulk the gap between the roof flashing and the outside diameter of the pipe.
- Caulk the perimeter of the flashing where it contacts the roof surface. See Figure 43.

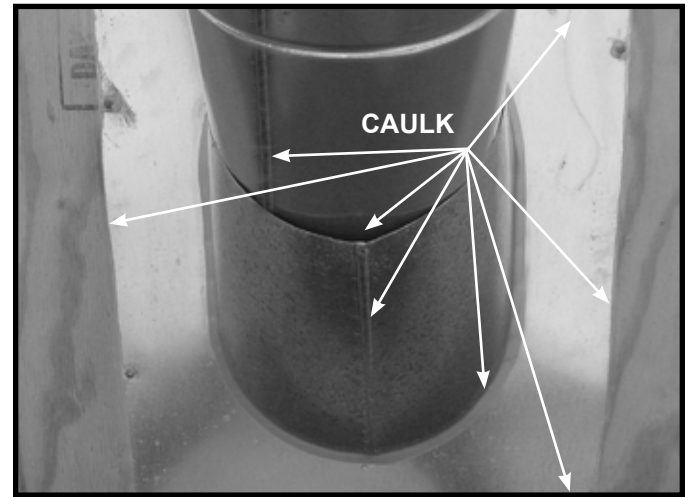
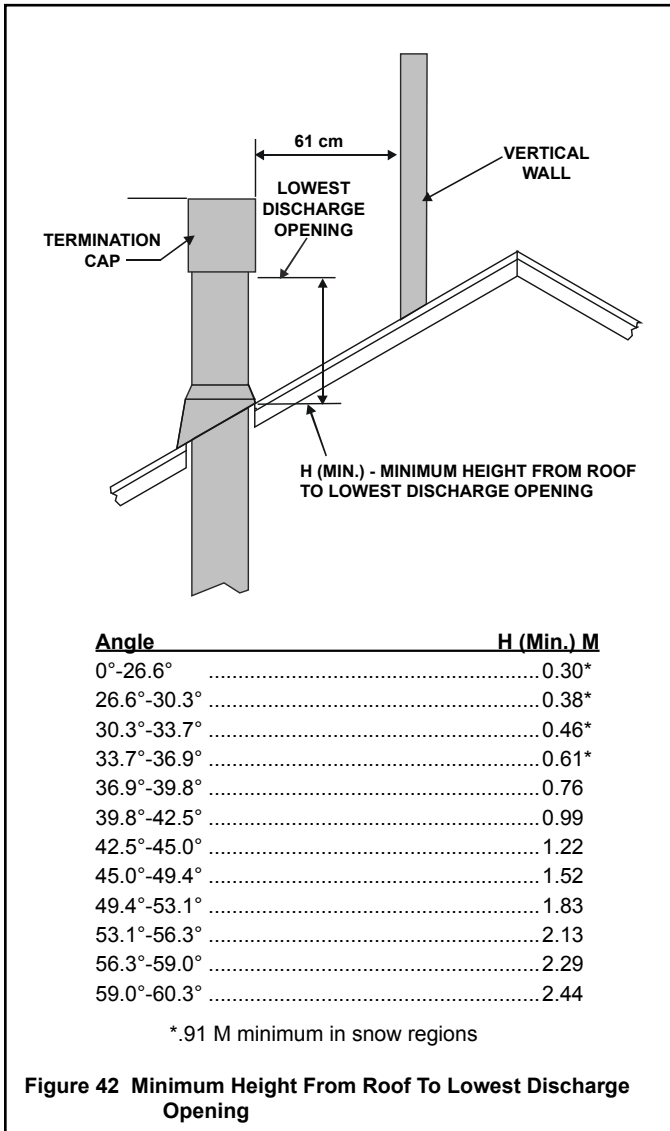

Figure 43

J. Installing Vertical Termination Cap

- Attach the vertical termination cap by sliding the inner collar of the cap into the inner flue of the pipe section while placing the outer collar of the cap over the outer flue of the pipe section.
- Secure the cap by driving three self-tapping screws (supplied) through the pilot holes in the outer collar of the cap into the outer flue of the pipe (see Figure 44).



Figure 44

K. Assemble and Install Storm Collar

CAUTION! Risk of Cuts, Abrasions or Flying Debris. Wear protective gloves and safety glasses during installation. Sheet metal edges are sharp.

- Connect both halves of the storm collar with two screws (see Figure 45).
- Wrap the storm collar around the exposed pipe section closest to the roof and align brackets. Insert a bolt (provided) through the brackets and tighten the nut to complete the storm collar assembly. Make sure the collar is tight against the pipe section.
- Slide the assembled storm collar down the pipe section until it rests on the roof flashing (see Figure 44).
- Caulk around the top of the storm collar (see Figure 44).

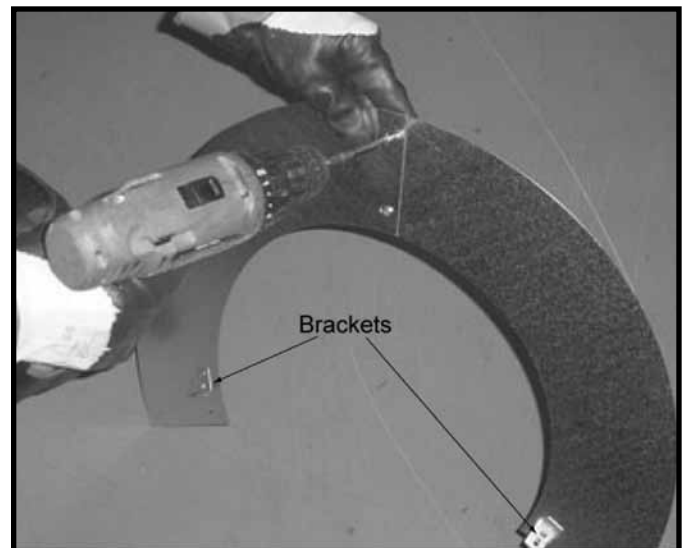

Figure 45 Assembling the Storm Collar



Figure 46 Assembling the Storm Collar Around the Pipe

L. Heat Shield Requirements for Horizontal Termination

For all horizontally vented appliances, a heat shield **MUST** be placed 2.5 cm above the top of the flue pipe between the wall shield firestop and the base of the termination cap.

There are two sections of the heat shield. One section is factory-attached to the wall shield firestop. The other section is factory-attached to the cap. See Figure 47.

If the wall thickness does not allow the required 4 cm heat shield overlap when installed, an extended heat shield must be used.

WARNING! Risk of Fire! To prevent overheating and fire, heat shields must extend through the entire wall thickness. Heat shields must overlap 4 cm minimum.

- **DO NOT** remove the heat shields attached to the wall shield firestop and the horizontal termination cap (shown in Figure 47).
- If the wall thickness is less than 10 cm (DVP) or 11 cm (SLP), the heat shields on the cap and wall shield firestop must be trimmed. A minimum 4 cm overlap **MUST** be maintained.
- Use an extended heat shield if the finished wall thickness is greater than 18.4 cm.
- The extended heat shield may need to be cut to length maintaining sufficient length for a 4 cm overlap between heat shields.
- Attach the extended heat shield to either of the existing heat shields using the screws supplied with the extended heat shield.
- Rest the small leg on the extended heat shield on top of the pipe section to properly space it from the pipe section.

Important Notice: Heat shields may not be field constructed.

Install Horizontal Termination Cap

WARNING! Risk of Fire! The telescoping flue section of the termination cap **MUST** be used when connecting flue pipe.

- 38 cm) minimum overlap of flue telescoping section is required.

Failure to maintain overlap may cause overheating and fire.

- Termination caps must not be recessed in the wall. Siding may be brought to the edge of the cap base.
- Flash and seal as appropriate for siding material at outside edges of cap.

CAUTION! Risk of Burns! Local codes may require installation of a cap shield to prevent anything or anyone from touching the hot cap.

NOTICE: For certain exposures which require superior resistance to wind-driven rain penetration, a flashing kit and HRC caps are available. When penetrating a brick wall, a brick extension kit is available for framing the brick.

Note: When using termination caps with factory-supplied heat shield attached, no additional wall shield firestop is required on the exterior side of a combustible wall.

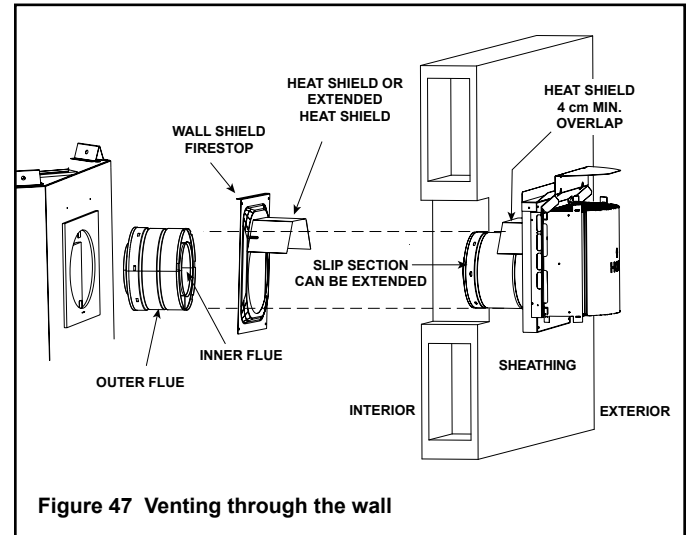

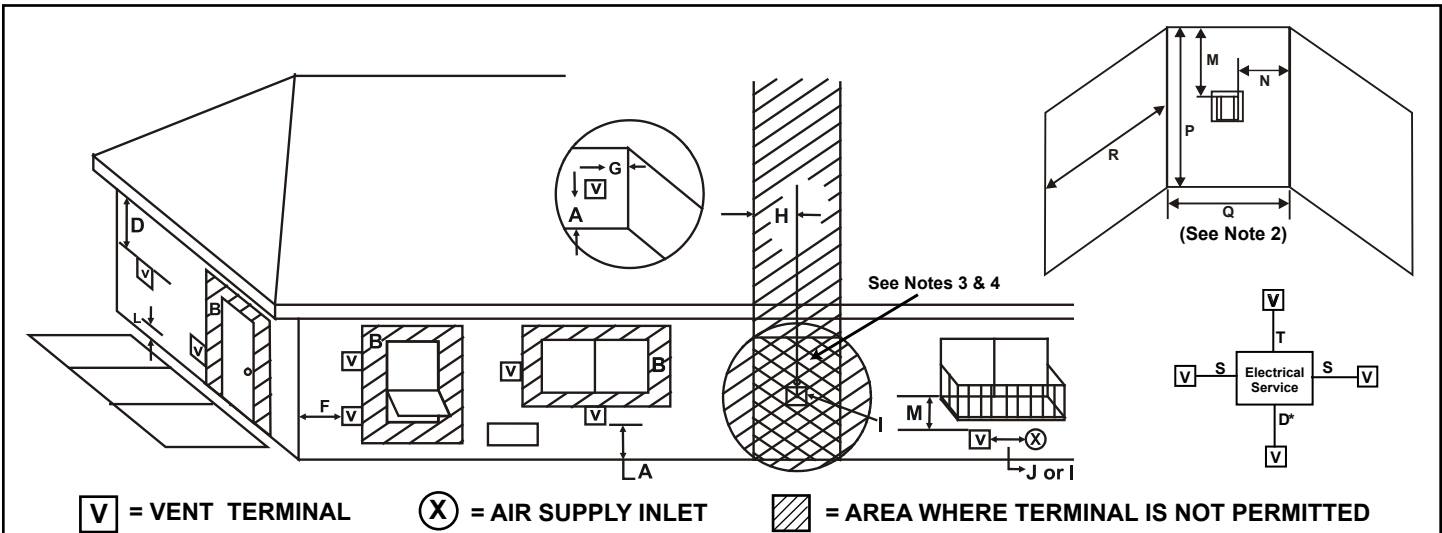

V = VENT TERMINAL **X** = AIR SUPPLY INLET = AREA WHERE TERMINAL IS NOT PERMITTED

<p>A = 30.5 cmclearances above grade, veranda, porch, deck or balcony (See Note 1)</p> <p>B = 30.5 cmclearances to window or door that may be opened, or to permanently closed window. (Glass)</p> <p>D* = 45.8 cmvertical clearance to unventilated soffit or to ventilated soffit located above the terminal 76.2 cmfor vinyl clad soffits and below electrical service</p> <p>F = 22.9 cmclearance to outside corner</p> <p>G = 15.3 cmclearance to inside corner</p> <p>H = 91.4 cmnot to be installed above a gas meter/regulator assembly within 91.4 cm horizontally from the center-line of the regulator</p> <p>I = 91.4 mclearance to gas service regulator flue outlet</p> <p>J = 22.9 cmclearance to non-mechanical air supply inlet to building or the combustion air inlet to any other appliance</p>	<p>K = 91.4 mclearance to a mechanical (powered) air supply inlet</p> <p>L = 2.1 mclearance above paved sidewalk or a paved driveway located on public property (See Note 1)</p> <p>M* = 45.8 cmclearance under veranda, porch, deck, balcony or overhang 106.7 mvinyl</p> <p>S = 15.3 cmclearance from sides of electrical service (See Note 5)</p> <p>T = 30.5 cmclearance above electrical service (See Note 5)</p>
---	---

Alcove Applications

N = 15.3 cmnon-vinyl sidewalls
30.5 cmvinyl sidewalls

P = 2.4 m

	Q_{MIN}	R_{MAX}
1 cap	.91 m	2 x Q_{ACTUAL}
2 caps	1.8 m	1 x Q_{ACTUAL}
3 caps	2.7 m	2/3 x Q_{ACTUAL}
4 caps	3.7 m	1/2 x Q_{ACTUAL}

$Q_{MIN} = \# \text{ termination caps} \times 3$ $R_{MAX} = (2 / \# \text{ termination caps}) \times Q_{ACTUAL}$

* only permitted if veranda, porch, deck or balcony is fully open on a minimum of 2 sides beneath the floor, or meets Note 2.

NOTE 1: On private property where termination is less than 2.1 M above a sidewalk, driveway, deck, porch, veranda or balcony, use of a listed cap shield is suggested. (See vents components page)

NOTE 2: Termination in an alcove space (spaces open only on one side and with an overhang) are permitted with the dimensions specified for vinyl or non-vinyl siding and soffits. **1.** There must be 91.4 cm minimum between termination caps. **2.** All mechanical air intakes within 3.0 M of a termination cap must be a minimum of 91.4 cm below the termination cap. **3.** All gravity air intakes within 91.4 cm of a termination cap must be a minimum of 30.5 cm below the termination cap.

NOTE 3: Local codes or regulations may require different clearances.

NOTE 4: Termination caps may be hot. Consider their proximity to doors or other traffic areas.

NOTE 5: Location of the termination cap must not interfere with access to the electrical service.

NOTE: Termination cap is permitted in porch areas with two or more sides open. You must follow all side walls, overhang and ground clearances as stated in the instructions.

Heat & Glo assumes no responsibility for the improper performance of the appliance when the venting system does not meet these requirements.

Figure 48 Termination Caps Minimum Clearances

CAUTION: IF EXTERIOR WALLS ARE FINISHED WITH VINYL SIDING, IT IS SUGGESTED THAT A VINYL PROTECTOR KIT BE INSTALLED.

Step 4 Positioning, Leveling, and Securing the Fireplace

1. Place the fireplace into position.
2. Level the fireplace from side to side and from front to back.
3. Shim the fireplace with non-combustible material, such as sheet metal, as necessary.
4. Secure the fireplace to the framing by nailing or screwing.

The diagram below shows how to properly position, level, and secure the fireplace.

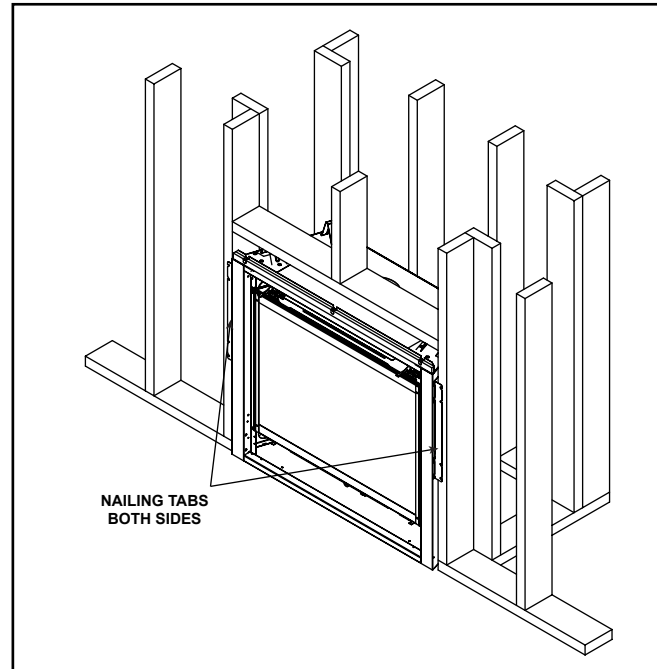

Figure 49. Proper Positioning, Leveling, and Securing of a Fireplace

Step 5 The Gas Control System



WARNING: THIS UNIT IS NOT FOR USE WITH SOLID FUEL.

This system includes millivolt control valve, standing pilot, thermopile/thermocouple flame sensor, and piezo ignitor.



WARNING: 230 VAC MUST NEVER BE CONNECTED TO A CONTROL VALVE IN A MILLIVOLT SYSTEM.

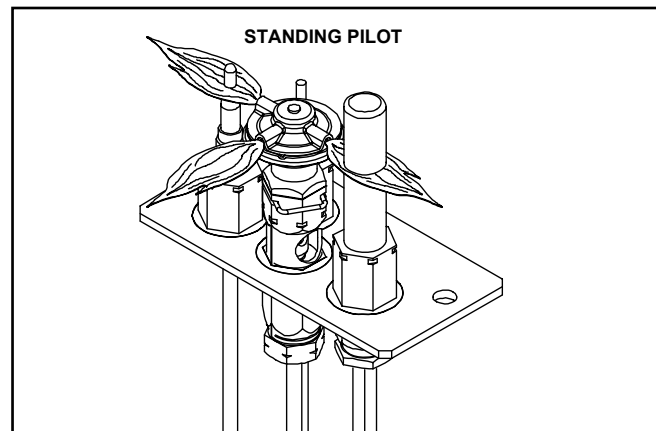

Figure 50. Gas Control System

Step 6 The Gas Supply Line

Note: Have the gas supply line installed by a qualified service technician in accordance with all building regulations.

Note: Before the first firing of the fireplace, the gas supply line should be purged of any trapped air.

NOTE: Consult local building regulations to properly size the gas supply line leading to the (Rp 1/2") hook-up at the unit.

This gas inlet connection is ISO 7-Rp 1/2 (BSP Rp 1/2).

To install the gas supply line:

- When attaching the flue pipe, support the control so that the lines are not bent or torn.
- After the gas line installation is complete, use a soap solution to carefully check all gas connections for leaks.

 **WARNING: DO NOT USE AN OPEN FLAME TO CHECK FOR GAS LEAKS.**

- At the gas line access hole, use insulation to repack the space around the gas pipe.
- Insert insulation from the outside of the fireplace and pack the insulation tightly to totally seal between the pipe and the outer casing.

The gas line should be installed by a qualified service technician.

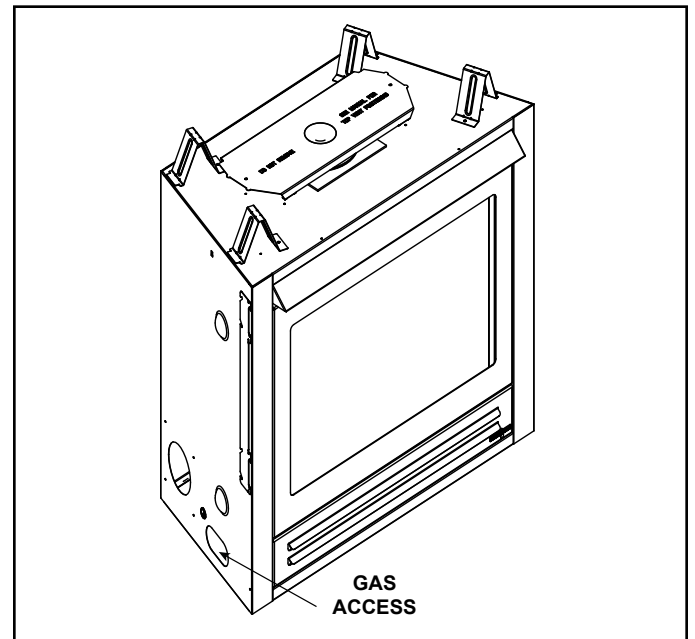

Figure 51

Step 7 Gas Pressure Requirements

Pressure requirements for Heat & Glo gas fireplaces are shown in the table below.

	Natural Gas	Propane	Butane	Natural Gas
	(G20)	(G31)	(G30)	(G25)
Inlet Pressure	20 mbar	30 or 50 mbar	30 or 50 mbar	25 mbar
Manifold Pressure	4 - 8.7 mbar	15.7 - 25 mbar	15.7 - 25 mbar	4 - 8.7 mbar
Gas Rate	.54 m ³ /h	.24 m ³ /h	.16 m ³ /h	.54 m ³ /h
Max. Input (NETCV)	6.0 kW	5.4 kW	5.2 kW	5.0 kW
Burner Injector	DMS 44	DMS 55	DMS 56	DMS 42
Pilot Injector	51	30	30	51

A tap is provided on the outlet side of the gas control for a test gauge connection to measure the manifold pressure. To measure inlet pressure, provisions must be made to attach a test gauge to the tap immediately upstream of the gas supply connection to the fireplace.

The fireplace and its individual shut-off valve must be disconnected from the gas supply piping system during any pressure testing of the system at test pressures in excess of 60 mbar.

If the fireplace must be isolated from the gas supply piping system by closing an individual shut-off valve, it must be of the handle-less type.

Step 8 Wiring the Fireplace

NOTE: Electrical wiring must be installed by a competent electrician.

Appliance Requirements

- This appliance **DOES NOT** require 230 VAC to operate.



WARNING: DO NOT CONNECT 230 VAC TO THE GAS CONTROL VALVE OR THE APPLIANCE WILL MALFUNCTION AND THE VALVE WILL BE DESTROYED.

Optional Accessories

Optional remote control kits require that 230 VAC be wired to the factory installed junction box before the fireplace is permanently installed.

Wall Switch

Position the wall switch in the desired position on a wall. Run a maximum of 780 cm or less length of 0.102 cm diameter minimum wire and connect it to the fireplace ON/OFF switch pigtails.



WARNING: DO NOT CONNECT 230 VAC TO THE WALL SWITCH OR THE CONTROL VALVE WILL BE DESTROYED.

CAUTION

LABEL ALL WIRES PRIOR TO DISCONNECTION WHEN SERVICING CONTROLS. WIRING ERRORS CAN CAUSE IMPROPER AND DANGEROUS OPERATION. VERIFY PROPER OPERATION AFTER SERVICING.

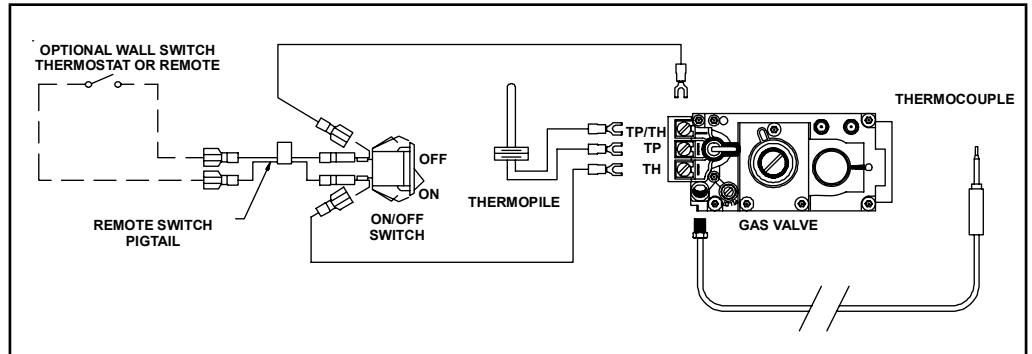

Figure 52. Standing Pilot Ignition Wiring Diagram

**Step 9
Finishing**

The following diagram shows the minimum vertical and corresponding maximum horizontal dimensions of fireplace mantels or other combustible projections above the top front edge of the fireplace. See Figures 2, 3 and 4 for other fireplace clearances.

Only non-combustible materials may be used to cover the black fireplace front.

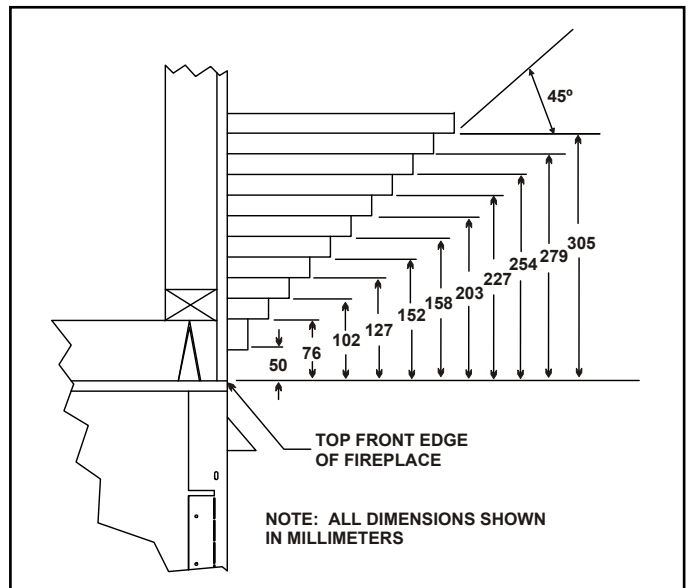

Figure 53. Minimum Vertical and Maximum Horizontal Dimensions of Combustibles above Fireplace



WARNING: WHEN FINISHING THE FIREPLACE, NEVER OBSTRUCT OR MODIFY THE AIR INLET/OUTLET GRILLES IN ANY MANNER.

CAUTION

IF JOINTS BETWEEN THE FINISHED WALLS AND THE FIREPLACE SURROUND (TOP AND SIDES) ARE SEALED, A 150° C. MINIMUM SEALANT MATERIAL MUST BE USED. THESE JOINTS ARE NOT REQUIRED TO BE SEALED. ONLY NONCOMBUSTIBLE MATERIAL (USING 150° C. MINIMUM ADHESIVE, IF NEEDED) CAN BE APPLIED AS FACING TO THE FIREPLACE SURROUND. SEE THE DIAGRAM BELOW.

1. Apply only non-combustible facing material to the fireplace surround.

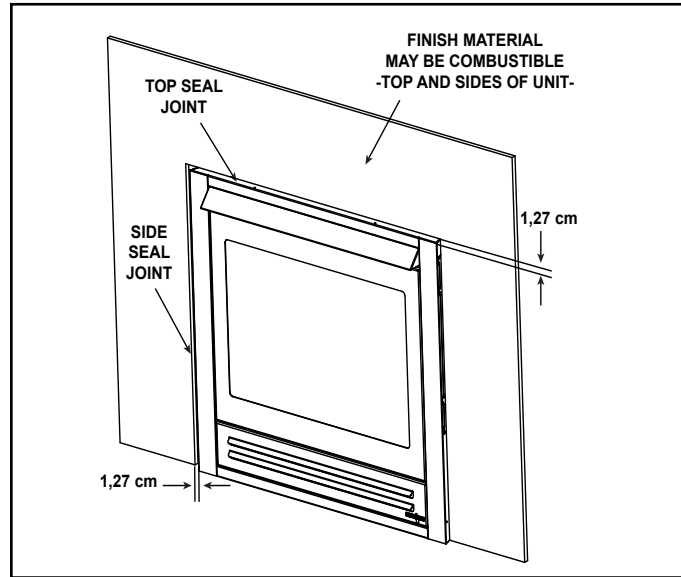

Figure 54. Sealant Material

Step 10

Installing Trim, Logs, and Ember Material

Installing the Trim

Combustible materials may be brought up to the specified clearances on the side and top front edges of the fireplace, but **MUST NEVER** overlap onto the front face. The joints between the finished wall, fireplace top and sides can only be sealed with a 150° C minimum sealant.

Install optional marble and brass trim surround kits as desired. Marble, brass, brick, tile, or other noncombustible materials can be used to cover up the gap between the sheet rock and the fireplace.

Do not obstruct or modify the air inlet/outlet grilles. When overlapping on both sides, leave enough space so that the bottom grille can be opened and the trim door removed.



WARNING: CHILDREN AND ADULTS SHOULD BE ALERTED TO THE HAZARDS OF HIGH TEMPERATURES OF WORKING SURFACES ON THESE HEATERS. WORKING SURFACES INCLUDE ALL GLASS PANELS AND DECORATIVE DOORS. YOUNG CHILDREN SHOULD BE CAREFULLY SUPERVISED WHEN THEY ARE IN THE SAME ROOM AS THE APPLIANCE.

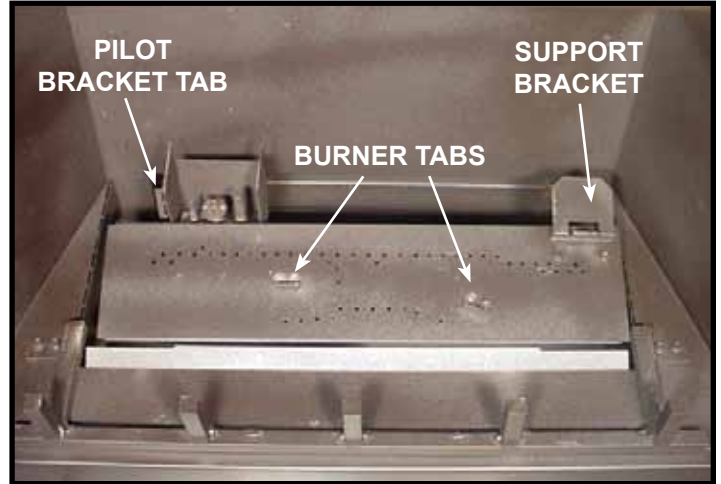

Carefully remove the logs from the packaging. **CAUTION:** Logs are fragile!

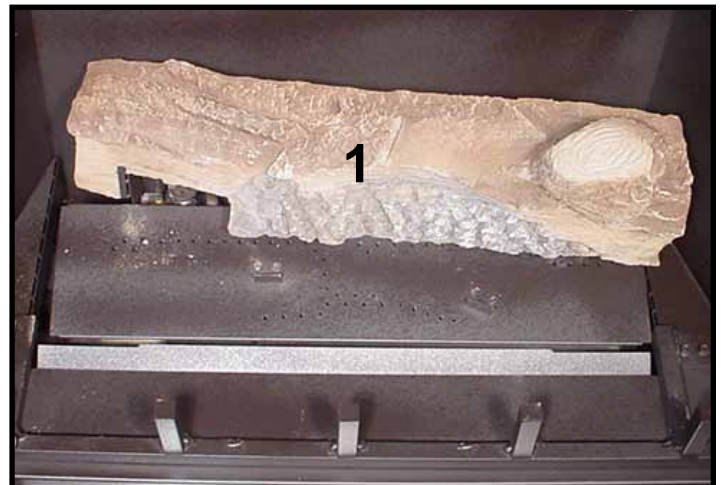

LOG #1 (SRV327-701): Place log #1 at the rear of the unit, with the left edge behind the tab on the pilot bracket. The right side sits behind the tab on the support bracket.



LOG #2 (SRV2033-701): Locate the bottom groove of log #2 over the left most grate bar and align over the burner by placing the log slot over the burner tab as shown.



LOG #3 (SRV705-703): Rest log #3 against the right front grate corner and place its slot over the right burner tab.

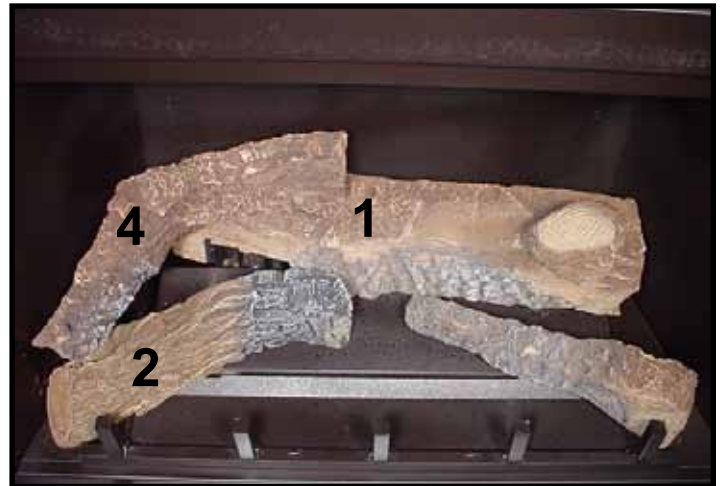

LOG #4 (SRV530-716): Place the left end of log #4 in the groove on log #2 and the right end on log #1 as shown.

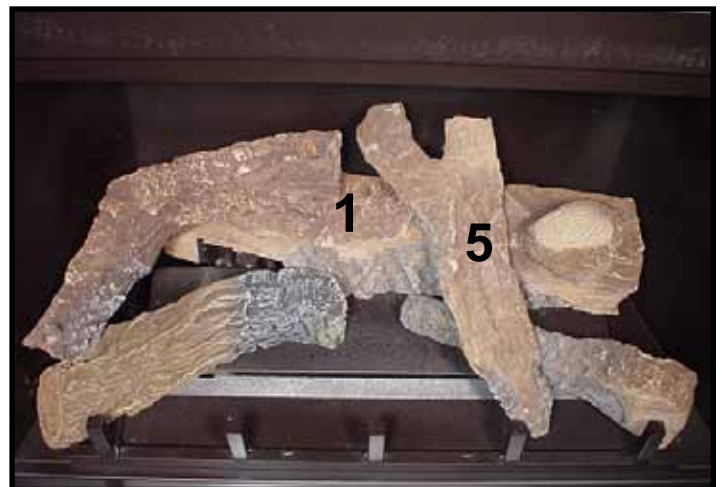
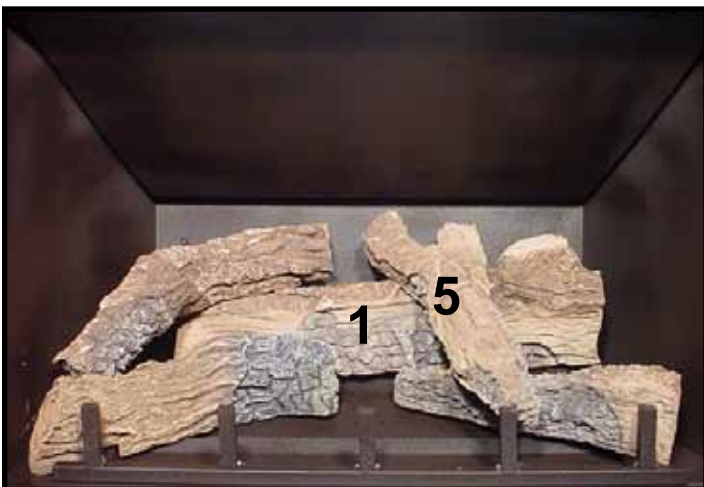

LOG #5 (SRV438-724): Locate the top of log #5 onto log #1 and place the bottom on the right side of the fourth log grate.



LOG #6 (SRV540-704): Place log #6 against the second and third grate bars.

If sooting occurs, the logs might need to be repositioned slightly to avoid excessive flame impingement.

Placing the Ember Material

Ember material is shipped with this gas fireplace. The bag labeled Glowing Ember (050-721) is standard glowing ember material. To place the ember material:

- Remove latches and tension springs around the glass door.
- Remove the glass door from the unit (Figure 55).
- Place small pieces of ember material on burner top around burner ports (Figure 56). Do NOT press embers into burner ports. Cover the top of the burner with a single layer of ember material. Do NOT place embers behind the rear port row as noted in Figure 56.
- Save the remaining ember materials for use during fireplace servicing.

- Replace the glass door and a front trim door on the unit (see Replacement Parts Section of the manual.)
- Replace the latches and tension springs.

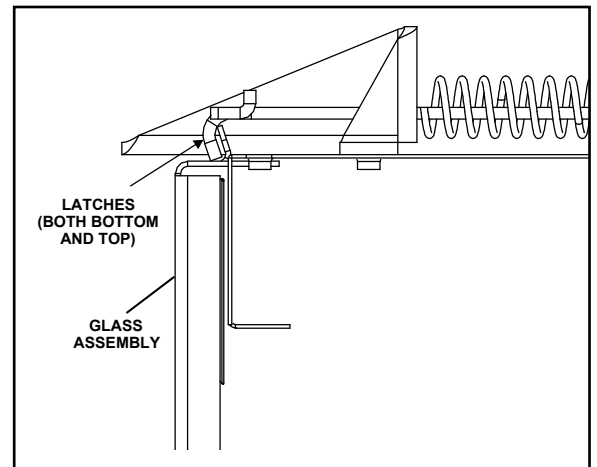

Figure 55. Glass Assembly

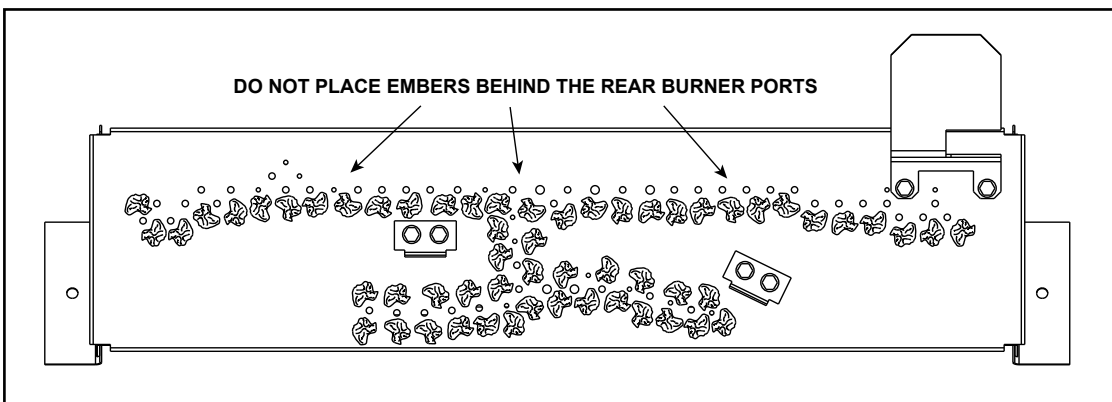

Figure 56. Placement of the Ember Material

Step 11 Before Lighting the Fireplace

Before lighting the fireplace, be sure to do the following:

Review safety warnings and cautions

- Read the **Safety and Warning Information** section at the beginning of this *Installers Guide*.

Double-check for gas leaks

- Before lighting the fireplace, double-check the unit for possible gas leaks.

Double-check flue terminations and front grilles for obstructions.

- Before lighting the fireplace, double-check the unit for possible obstructions that could be blocking the flue terminations or the front grilles.

Double-check for faulty components

- Any component that is found to be faulty **MUST BE** replaced with an approved component. Tampering with the fireplace components is **DANGEROUS** and voids all warranties.

A small amount of air will be in the gas supply lines. When first lighting the fireplace, it will take a few minutes for the lines to purge themselves of this air. Once the purging is complete, the fireplace will light and will operate normally.

Subsequent lightings of the fireplace will not require this purging of air from the gas supply lines, **unless the gas valve has been turned to the OFF position**, in which case the air would have to be purged.

NOTE: The fireplace should be run for 3 to 4 hours on the initial start-up. Turn it off and let it cool completely. Remove and clean the glass. Replace the glass and run the fireplace for an additional 8 hours. This will help to cure the products used in the paint and logs.

During this break-in period it is recommended that some windows in the house be opened for air circulation. This will help avoid setting off smoke detectors, and help eliminate any odors associated with the fireplace's initial burning.

Step 12 Lighting the Fireplace

You've reviewed all safety warnings, you've checked the fireplace for gas leaks, you know the flue system is unobstructed, and you've checked for faulty components. Now you're ready to light the fireplace.



WARNING: PLEASE REFER TO THE USER'S MANUAL FOR ALL CAUTIONS, SAFETY, AND WARNING INFORMATION PERTAINING TO THE LIGHTING AND OPERATION OF THE FIREPLACE.

After the Installation

LEAVE THIS INSTALLATION MANUAL WITH THE APPLIANCE FOR FUTURE REFERENCE.

4

Maintaining and Servicing Your Fireplace

Fireplace Maintenance

Although the frequency of your appliance servicing and maintenance will depend on use and the type of installation, you should have a qualified service technician perform an appliance checkup at the beginning of each heating season. See the table below for specific guidelines regarding each fireplace maintenance task.

IMPORTANT *TURN OFF THE GAS BEFORE SERVICING YOUR FIREPLACE.*

Type of Fireplace Maintenance	Frequency	By	Fireplace Maintenance Task To Be Completed
Replacing Old Ember Material	Once annually, during the annual checkup	Qualified Service Technician	Brush away loose ember material near the burner. Replace old ember material with 1 cm thin pieces of Glowing Ember (050-721). New ember material should be placed on top of the burner. Save the remaining ember material and repeat this procedure at your next servicing. For more information, see Placing Ember Material in the INSTALLERS GUIDE.
Cleaning Burner and Controls	Once annually	Qualified Service Technician	Brush or vacuum the control compartment, and burner areas surrounding the logs.
Checking Flame Patterns, Flame Height	Periodically	Qualified Service Technician/ Owner	Make a visual check of your fireplace's flame patterns. Make sure the flames are steady, not lifting or floating. See the picture in Figure 35. The thermopile/thermocouple tips should be covered with flame. See picture in Figure 36.
Checking Flue System	Before initial use and at least annually thereafter, more frequently if possible	Qualified Service Technician/ Owner	Inspect the external terminal cap on a regular basis to ensure that no debris is interfering with the flow of air, Inspect entire flue system for proper function.
Cleaning Glass Door	After the first 3-4 hours of use. As necessary after initial cleaning.	Qualified Service Technician	Remove and clean glass after the first 3 to 4 hours of use. After the initial cleaning, clean as necessary, particularly after adding new ember material. Film deposits on the inside of the glass door should be cleaned off using a household glass cleaner. NOTE: DO NOT handle or attempt to clean the door when it is hot and DO NOT use abrasive cleaners.

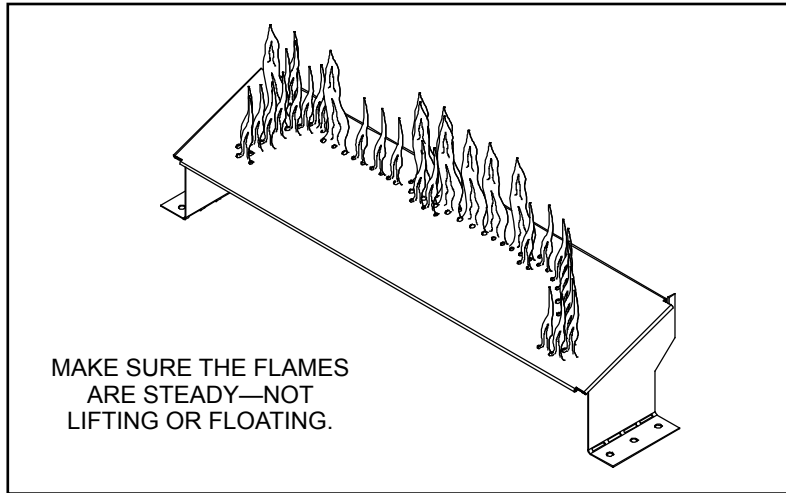

Figure 57. Burner Flame Patterns

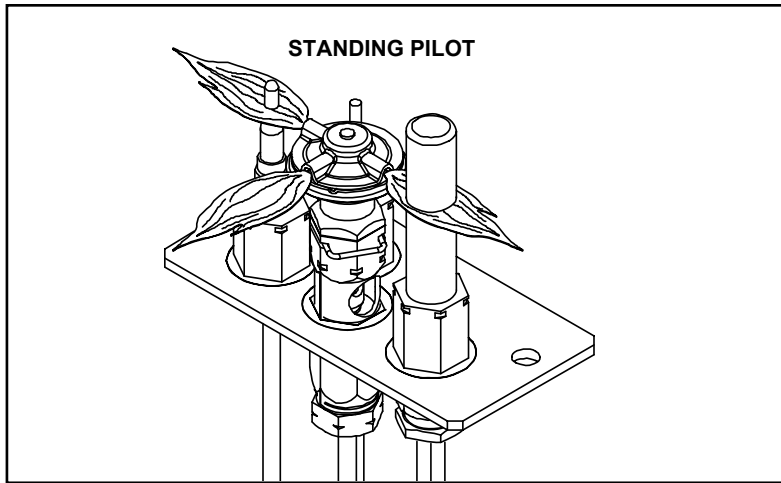

Figure 58. Pilot Flame Patterns

5

Trouble-shooting

With proper installation, operation, and maintenance your gas fireplace will provide years of trouble-free service. If you do experience a problem, this troubleshooting guide will assist a qualified service person in the diagnosis of a problem and the corrective action to be taken. This troubleshooting guide can only be used by a qualified service technician.

Standing Pilot Troubleshooting

Symptom	Possible Cause	Corrective Action
1. After repeated triggering of the red or black piezo button, the spark ignitor will not light the pilot.	a. Defective ignitor	Check the spark at the electrode and pilot. If no spark and electrode wire is properly connected, replace the ignitor.
	b. Defective pilot or misaligned electrode (spark at electrode)	Using a match, light the pilot. If the pilot lights, turn off the pilot and trigger the red or black piezo button again. If the pilot lights, an improper gas/air mixture caused the bad lighting and a longer purge period is recommended. If the pilot will not light, ensure that the gap at the electrode and pilot is 0.3 cm to have a strong spark. If the gap is OK, replace the pilot.
	c. No gas or low gas pressure	Check the remote shut-off valves from the fireplace. Usually, there is a valve near the gas main. There can be more than one (1) valve between the fireplace and the main.
	d. No LP in the tank	Check the LP (propane) tank. You may be out of fuel.
2. The pilot will not stay lit after carefully following the lighting instructions.	a. Defective thermocouple	Check that the pilot flame impinges on the thermocouple. Clean and/or adjust the pilot for maximum flame impingement. Ensure that the thermocouple connection at the gas valve is fully inserted and tight (hand tighten plus 1/4 turn). Disconnect the thermocouple from the valve, place one millivolt meter lead wire on the tip of the thermocouple and the other meter lead wire on the thermocouple copper lead. Start the pilot and hold the valve knob in. If the millivolt reading is less than 15mV, replace the thermocouple.
	b. Defective valve	If thermocouple is producing more than 15 millivolts, replace faulty valve.
3. The pilot is burning, there is no gas burner, the valve knob is in the ON position, and the ON/OFF switch is in the ON position.	a. ON/OFF switch or wires defective	Check the ON/OFF switch and wires for proper connections. Place the jumper wires across the terminals at the switch. If the burner comes on, replace the defective switch. If the switch is OK, place the jumper wires across the switch wires at the gas valve. If the burner comes on, the wires are faulty or connections are bad.
	b. Thermopile may not be generating sufficient millivoltage	If the pilot flame is not close enough physically to the thermopile, adjust the pilot flame. Be sure the wire connections from the thermopile at the gas valve terminals are tight and that the thermopile is fully inserted into the pilot bracket.

Symptom	Possible Cause	Corrective Action
3. (Continued)	b. Thermopile may not be generating sufficient millivoltage	<p>Check the thermopile with a millivolt meter. Take the reading at TH-TP&TP terminals of the gas valve. The meter should read 325 millivolts minimum, while holding the valve knob depressed in the pilot position, with the pilot lit, and the ON/OFF switch in the OFF position. Replace the faulty thermopile if the reading is below the specified minimum.</p> <p>With the pilot in the ON position, disconnect the thermopile leads from the valve. Take a reading at the thermopile leads. The reading should be 325 millivolts minimum. Replace the thermopile if the reading is below the minimum.</p>
	c. Defective valve	Turn the valve knob to the ON position. Place the ON/OFF switch in the ON position. Check the millivolt meter at the thermopile terminals. The millivolt meter should read greater than 125mV. If the reading is acceptable, and if the burner does not come on, replace the gas valve.
	d. Plugged burner orifice	Check the burner orifice for stoppage. Remove stoppage.
	e. Wall switch or wires are defective	Follow the corrective action in Symptom and Possible Cause 1. a. above. Check the switch and wiring. Replace where defective.
4. Frequent pilot outage problem.	a. Pilot flame may be too high or too low, or blowing (high), causing pilot safety to drop out	Clean and adjust the pilot flame for maximum flame impingement on thermocouple. Follow lighting instructions carefully.

Symptom	Possible Cause	Corrective Action
5. The pilot and main burner extinguish while in operation.	a. No LP in the tank	Check the LP (propane) tank. Refill the fuel tank.
	b. Inner flue pipe leaking exhaust gases back into the system	Check for gas leaks.
	c. Horizontal flue improperly pitched	The horizontal flue cap should slope down only enough to prevent any water from entering the unit. The maximum downward slope is 0.6 cm.
	d. Glass too loose and air tight packet leaks in corners after usage	Tighten the corner.
	e. Bad thermopile or thermocouple	Replace if necessary.
	f. Improper flue cap installation	Check for proper installation and freedom from debris or blockage.
6. Glass soots.	a. Flame impingement	Adjust the log set so that the flame does not excessively impinge on it.
	b. Improper venturi setting	Adjust the air shutter at the base of the burner.
	c. Debris around venturi	Inspect the opening at the base of the burner. NO MATERIAL SHOULD BE PLACED IN THIS OPENING.
7. Flame burns blue and lifts off burner.	a. Insufficient oxygen being supplied	Ensure that the flue cap is installed properly and free of debris. Ensure that the flue system joints are tight and have no leaks. Ensure that no debris has been placed in the area at the base of, or in the area of, the air holes in the center of the base pan beneath the burner. Ensure that the glass is tightened properly on the unit, particularly on top corners.

Limited Lifetime Warranty

Hearth & Home Technologies Inc. LIMITED LIFETIME WARRANTY

Hearth & Home Technologies Inc., on behalf of its hearth brands ("HHT"), extends the following warranty for HHT gas, wood, pellet, coal and electric hearth appliances that are purchased from an HHT authorized dealer.

WARRANTY COVERAGE:

HHT warrants to the original owner of the HHT appliance at the site of installation, and to any transferee taking ownership of the appliance at the site of installation within two years following the date of original purchase, that the HHT appliance will be free from defects in materials and workmanship at the time of manufacture. After installation, if covered components manufactured by HHT are found to be defective in materials or workmanship during the applicable warranty period, HHT will, at its option, repair or replace the covered components. HHT, at its own discretion, may fully discharge all of its obligations under such warranties by replacing the product itself or refunding the verified purchase price of the product itself. The maximum amount recoverable under this warranty is limited to the purchase price of the product. This warranty is subject to conditions, exclusions and limitations as described below.

WARRANTY PERIOD:

Warranty coverage begins on the date of original purchase. In the case of new home construction, warranty coverage begins on the date of first occupancy of the dwelling or six months after the sale of the product by an independent, authorized HHT dealer/ distributor, whichever occurs earlier. The warranty shall commence no later than 24 months following the date of product shipment from HHT, regardless of the installation or occupancy date. The warranty period for parts and labor for covered components is produced in the following table.

The term "Limited Lifetime" in the table below is defined as: 20 years from the beginning date of warranty coverage for gas appliances, and 10 years from the beginning date of warranty coverage for wood, pellet, and coal appliances. These time periods reflect the minimum expected useful lives of the designated components under normal operating conditions.

Warranty Period		HHT Manufactured Appliances and Venting							Components Covered
Parts	Labor	Gas	Wood	Pellet	EPA Wood	Coal	Electric	Venting	
1 Year		X	X	X	X	X	X	X	All parts and material except as covered by Conditions, Exclusions, and Limitations listed
2 years				X	X	X			Igniters, electronic components, and glass
		X	X	X	X	X			Factory-installed blowers
			X						Molded refractory panels
3 years				X					Firepots and burnpots
5 years	1 year			X	X				Castings and baffles
7 years	3 years		X	X	X				Manifold tubes, HHT chimney and termination
10 years	1 year	X							Burners, logs and refractory
Limited Lifetime	3 years	X	X	X	X	X			Firebox and heat exchanger
90 Days		X	X	X	X	X	X	X	All replacement parts beyond warranty period

See conditions, exclusions, and limitations on next page.

WARRANTY CONDITIONS:

- This warranty only covers HHT appliances that are purchased through an HHT authorized dealer or distributor. A list of HHT authorized dealers is available on the HHT branded websites.
- This warranty is only valid while the HHT appliance remains at the site of original installation.
- Contact your installing dealer for warranty service. If the installing dealer is unable to provide necessary parts, contact the nearest HHT authorized dealer or supplier. Additional service fees may apply if you are seeking warranty service from a dealer other than the dealer from whom you originally purchased the product.
- Check with your dealer in advance for any costs to you when arranging a warranty call. Travel and shipping charges for parts are not covered by this warranty.

WARRANTY EXCLUSIONS:

This warranty does not cover the following:

- Changes in surface finishes as a result of normal use. As a heating appliance, some changes in color of interior and exterior surface finishes may occur. This is not a flaw and is not covered under warranty.
- Damage to printed, plated, or enameled surfaces caused by fingerprints, accidents, misuse, scratches, melted items, or other external sources and residues left on the plated surfaces from the use of abrasive cleaners or polishes.
- Repair or replacement of parts that are subject to normal wear and tear during the warranty period. These parts include: paint, wood, pellet and coal gaskets, firebricks, grates, flame guides, light bulbs, batteries and the discoloration of glass.
- Minor expansion, contraction, or movement of certain parts causing noise. These conditions are normal and complaints related to this noise are not covered by this warranty.
- Damages resulting from: (1) failure to install, operate, or maintain the appliance in accordance with the installation instructions, operating instructions, and listing agent identification label furnished with the appliance; (2) failure to install the appliance in accordance with local building codes; (3) shipping or improper handling; (4) improper operation, abuse, misuse, continued operation with damaged, corroded or failed components, accident, or improperly/incorrectly performed repairs; (5) environmental conditions, inadequate ventilation, negative pressure, or drafting caused by tightly sealed constructions, insufficient make-up air supply, or handling devices such as exhaust fans or forced air furnaces or other such causes; (6) use of fuels other than those specified in the operating instructions; (7) installation or use of components not supplied with the appliance or any other components not expressly authorized and approved by HHT; (8) modification of the appliance not expressly authorized and approved by HHT in writing; and/or (9) interruptions or fluctuations of electrical power supply to the appliance.
- Non-HHT venting components, hearth components or other accessories used in conjunction with the appliance.
- Any part of a pre-existing fireplace system in which an insert or a decorative gas appliance is installed.
- HHT's obligation under this warranty does not extend to the appliance's capability to heat the desired space. Information is provided to assist the consumer and the dealer in selecting the proper appliance for the application. Consideration must be given to appliance location and configuration, environmental conditions, insulation and air tightness of the structure.

This warranty is void if:

- The appliance has been over-fired or operated in atmospheres contaminated by chlorine, fluorine, or other damaging chemicals. Over-firing can be identified by, but not limited to, warped plates or tubes, rust colored cast iron, bubbling, cracking and discoloration of steel or enamel finishes.
- The appliance is subjected to prolonged periods of dampness or condensation.
- There is any damage to the appliance or other components due to water or weather damage which is the result of, but not limited to, improper chimney or venting installation.

LIMITATIONS OF LIABILITY:

- The owner's exclusive remedy and HHT's sole obligation under this warranty, under any other warranty, express or implied, or in contract, tort or otherwise, shall be limited to replacement, repair, or refund, as specified above. In no event will HHT be liable for any incidental or consequential damages caused by defects in the appliance. Some states do not allow exclusions or limitation of incidental or consequential damages, so these limitations may not apply to you. This warranty gives you specific rights; you may also have other rights, which vary from state to state. EXCEPT TO THE EXTENT PROVIDED BY LAW, HHT MAKES NO EXPRESS WARRANTIES OTHER THAN THE WARRANTY SPECIFIED HEREIN. THE DURATION OF ANY IMPLIED WARRANTY IS LIMITED TO DURATION OF THE EXPRESSED WARRANTY SPECIFIED ABOVE.