

**Model:
QVI-25FB**

Installers Guide

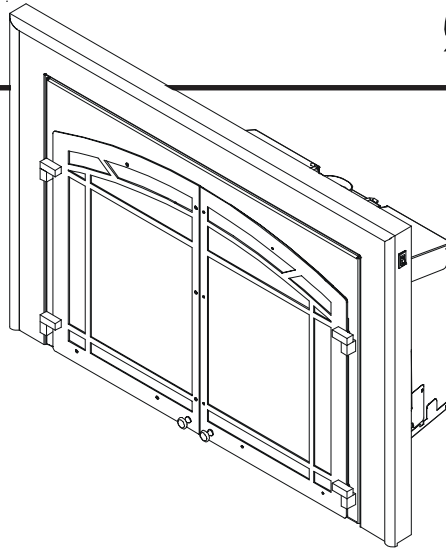

Underwriters
Laboratories Listed

READ THIS MANUAL BEFORE INSTALLING OR OPERATING THIS APPLIANCE. THIS *INSTALLERS GUIDE* MUST BE LEFT WITH APPLIANCE FOR FUTURE REFERENCE.

WARNING: IF THE INFORMATION IN THESE INSTRUCTIONS IS NOT FOLLOWED EXACTLY, A FIRE OR EXPLOSION MAY RESULT CAUSING PROPERTY DAMAGE, PERSONAL INJURY, OR DEATH.

- Do not store or use gasoline or other flammable vapors and liquids in the vicinity of this or any other appliance.
- **What to do if you smell gas**
 - Do not try to light any appliance.
 - Do not touch any electrical switch.
 - Do not use any phone in your building.
 - Immediately call your gas supplier from a neighbor's phone. Follow the gas supplier's instructions.
 - If you cannot reach your gas supplier, call the fire department.
- Installation and service must be performed by a qualified installer, service agency, or the gas supplier.

WARNING: IMPROPER INSTALLATION, ADJUSTMENT, ALTERATION, SERVICE OR MAINTENANCE CAN CAUSE INJURY OR PROPERTY DAMAGE. REFER TO THIS MANUAL. FOR ASSISTANCE OR ADDITIONAL INFORMATION CONSULT A QUALIFIED INSTALLER, SERVICE AGENCY, OR THE GAS SUPPLIER.

1. This appliance may be installed in an aftermarket, permanently located, manufactured (mobile) home, where not prohibited by local codes.
2. This appliance is only for use with the type of gas indicated on the rating plate. This appliance is not convertible for use with other gases, unless a certified kit is used.

In the Commonwealth of Massachusetts:

- installation must be performed by a licensed plumber or gas fitter;
- a CO detector shall be installed in the room where the appliance is installed.

Printed in U.S.A. Copyright 2007

QUADRA-FIRE®

Quadra-Fire,
a brand of Hearth & Home Technologies
1445 North Highway, Colville, WA 99114

Please contact your Quadra-Fire dealer with any questions or concerns. For the number of your nearest Quadra-Fire dealer, please visit www.quadrafire.com.

This product may be covered by one or more of the following patents: (United States) 4593510, 4686807, 4766876, 4793322, 4811534, 5000162, 5016609, 5076254, 5113843, 5191877, 5218953, 5263471, 5328356, 5341794, 5347983, 5429495, 5452708, 5542407, 5601073, 5613487, 5647340, 5688568, 5762062, 5775408, 5890485, 5931661, 5941237, 5947112, 5996575, 6006743, 6019099, 6048195, 6053165, 6145502, 6170481, 6237588, 6296474, 6374822, 6413079, 6439226, 6484712, 6543698, 6550687, 6601579, 6672860, 6688302B2, 6715724B2, 6729551, 6736133, 6748940, 6748942, D320652, D445174, D462436; (Canada) 1297749, 2195264, 2225408; or other U.S. and foreign patents pending.

SAFETY AND WARNING INFORMATION

 **READ** and **UNDERSTAND** all instructions carefully before starting the installation. **FAILURE TO FOLLOW** these installation instructions may result in a possible fire hazard and will void the warranty.

 Prior to the first firing of the appliance, **READ** the Using Your Appliance section of the *Owners Guide*.

 **DO NOT USE** this appliance if any part has been under water. Immediately **CALL** a qualified service technician to inspect the unit and to replace any part of the control system and any gas control which has been under water.

 **THIS UNIT IS NOT FOR USE WITH SOLID FUEL.**

 Installation and repair should be **PERFORMED** by a qualified service person. The appliance and venting system should be **INSPECTED** before initial use and at least annually by a professional service person. More frequent cleaning may be required due to excessive lint from carpeting, bedding material, etc. It is **IMPERATIVE** that the unit's control compartment, burners, and circulating air passageways **BE KEPT CLEAN** to provide for adequate combustion and ventilation air.

 Always **KEEP** the appliance clear and free from combustible materials, gasoline, and other flammable vapors and liquids.

 **NEVER OBSTRUCT** the flow of combustion and ventilation air. Keep the front of the appliance **CLEAR** of all obstacles and materials for servicing and proper operations.

 Due to the high temperature, the appliance should be **LOCATED** out of traffic areas and away from furniture and draperies. Clothing or flammable material **SHOULD NOT BE PLACED** on or near the appliance.

 Children and adults should be **ALERTED** to the hazards of high surface temperature and should **STAY AWAY** to avoid burns or clothing ignition. Young children should be **CAREFULLY SUPERVISED** when they are in the same room as the appliance.

 These units **MUST** use one of the vent systems described in the Installing the Appliance section of the *Installers Guide*. **NO OTHER** vent systems or components **MAY BE USED**.

 This gas appliance and vent assembly **MUST** be vented directly to the outside and **MUST NEVER** be attached to a chimney serving a separate solid fuel burning appliance. Each gas appliance **MUST USE** a separate vent system. Common vent systems are **PROHIBITED**.

 **INSPECT** the external vent cap on a regular basis to make sure that no debris is interfering with the air flow.

 The glass door assembly **MUST** be in place and sealed, and the trim door assembly **MUST** be in place on the appliance before the unit can be placed into safe operation.

 **DO NOT OPERATE** this appliance with the glass door removed, cracked, or broken. Replacement of the glass door should be performed by a licensed or qualified service person. **DO NOT** strike or slam the glass door.

 The glass door assembly **SHALL ONLY** be replaced as a complete unit, as supplied by the gas appliance manufacturer. **NO SUBSTITUTE** material may be used.

 **DO NOT USE** abrasive cleaners on the glass door assembly. **DO NOT ATTEMPT** to clean the glass door when it is hot.

 Turn off the gas before servicing this appliance. It is recommended that a qualified service technician perform an appliance check-up at the beginning of each heating season.

 Any safety screen or guard removed for servicing must be replaced before operating this appliance.

 **DO NOT** place furniture or any other combustible household objects within 36 inches of the appliance front.

TABLE OF CONTENTS

| | |
|--|-----------|
| Safety and Warning Information | 2 |
| → Service Parts Lists | 4 |
| Section 1: Approvals and Codes | 6 |
| Appliance Certification | 6 |
| Installation Codes | 6 |
| High Altitude Installations | 6 |
| Section 2: Getting Started | 7 |
| Introducing the Quadra-Fire Gas Appliances | 7 |
| Pre-installation Preparation | 7 |
| Venting and Installation | 7 |
| Insert Dimensions | 8 |
| Section 3: Installing the Insert | 9 |
| Step 1 Installing the Vent System | 9 |
| Step 2 Positioning, Leveling, and Securing the Insert | 13 |
| Step 3 The Gas Control Systems | 13 |
| Step 4 The Gas Supply Line | 13 |
| Step 5 Gas Pressure Requirements | 14 |
| Step 6 Wiring the Appliance | 14 |
| Wiring the Fan | 15 |
| Step 7 Installing Logs and Ember Material | 16 |
| Shutter Settings | 16 |
| Positioning the Logs | 16 |
| Placing the Ember Material | 16 |
| Step 8 Installing Trim Surround | 16 |
| Step 9 Before Lighting the Appliance | 17 |
| Step 10 Lighting the Appliance | 18 |
| Lighting Instructions | 18 |
| After the Installation | 18 |
| Section 4: Maintaining and Servicing Your Appliance | 19 |
| Section 5: Troubleshooting | 20 |
| Limited Lifetime Warranty | 22 |

→ = Contains updated information.

Service Parts Diagram

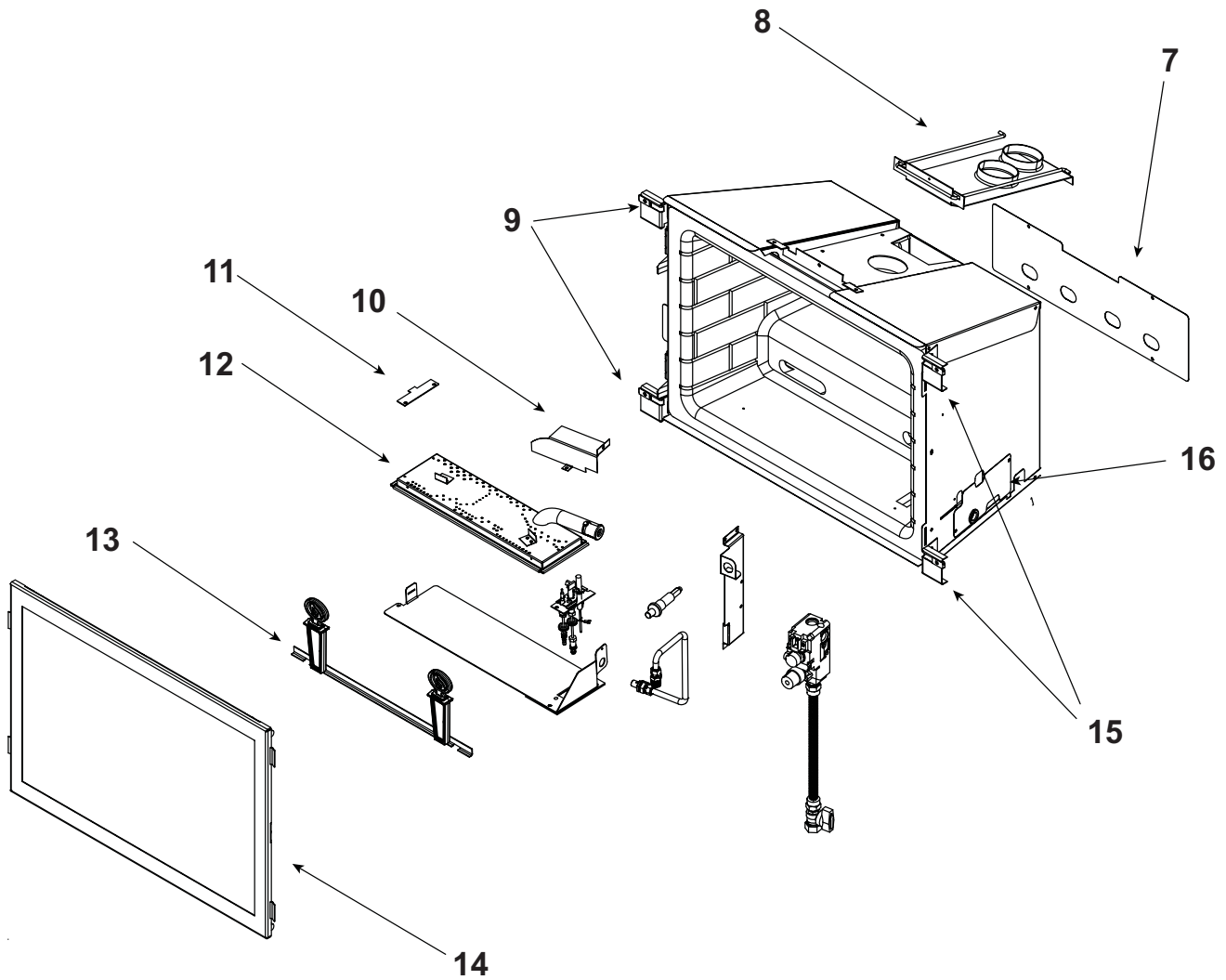

Log Set Assembly

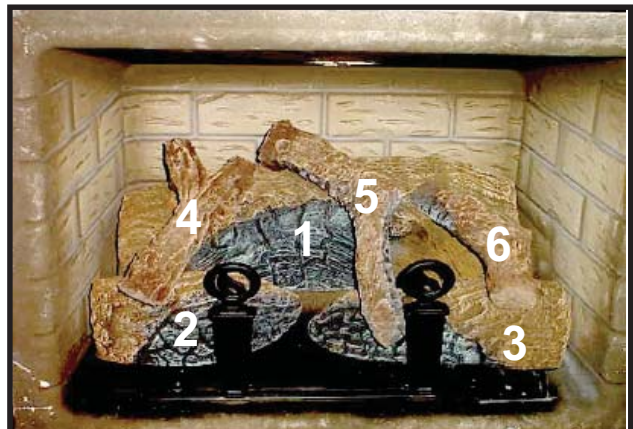

Part number list on following page.

Service Parts List

QVI-25FB

IMPORTANT: THIS IS DATED INFORMATION. The most current information is located on your dealers' VIP site. When ordering, supply serial and model numbers to ensure correct service parts.



**AVAILABLE
TO SHIP IN
24 HOURS**

| ITEM | DESCRIPTION | SERIAL # | PART NUMBER | AVAILABLE TO SHIP IN 24 HOURS |
|------|-----------------------|------------|---------------|-------------------------------|
| | Log Set Assembly | | LOGS-2031 | Y |
| 1 | Log 1 | | SRV2032-701 | |
| 2 | Log 2 | | SRV2032-702 | |
| 3 | Log 3 | | SRV2032-703 | |
| 4 | Log 4 | | SRV340-704 | |
| 5 | Log 5 | | SRV340-705 | |
| 6 | Log 6 | | SRV740-707 | |
| 7 | Access Plate: Fan | | 2019-111 | |
| 8 | Slide Plate Assembly | | 2019-096 | |
| | Slide Plate Handle | | 2019-201 | |
| 9 | Glass Latch Assembly | QTY 2 Req. | 386-122A | Y |
| 10 | Air Baffle | | 2019-165 | |
| 11 | Burner Key | | 2019-166 | |
| 12 | Burner NG, LP | | 2031-003 | Y |
| 13 | Grate Assembly | | 2031-020 | |
| | Andirion | | 434-0450 | |
| 14 | Glass Door Assembly | | GLA-2019 | Y |
| 15 | Glass Latch Assembly | QTY 2 Req. | 339-121A | |
| 16 | Access Plate | | 2019-116 | |
| | Surround Mount, Right | | 2019-205 | |
| | Surround Mount Left | | 2019-196 | |
| | Junction Box | | 040-250A | Y |
| | Blower Assembly | Optional | GFK-160A | |
| | Vent Pipe Assembly | | 768-380A | |
| | Gasket, Air Passage | | 2019-110 | |
| | Gasket, Cover Plate | | 2019-167 | |
| | Mineral Wool | | 050-721 | |
| | Vermiculite Embers | | MYSTIC-EMBERS | |
| | Thermocouple | | 446-511 | Y |
| | Thermopile | | 060-512 | Y |
| | Pilot tube | | SRV485-301 | Y |
| | Patch Kit | | SRV-PACK | |
| | Conversion Kit NG | | NGK-FBZC | Y |
| | Conversion Kit LP | | LPK-FBZC | Y |
| | Pilot Orifice NG | | 446-505 | Y |
| | Pilot Orifice LP | | 446-517 | Y |
| | Regulator NG | | 060-518 | Y |
| | Regulator LP | | 060-519 | Y |

Additional service part numbers appear on following page.

Valve Assembly Parts Diagram

Standing Pilot Valve Assembly

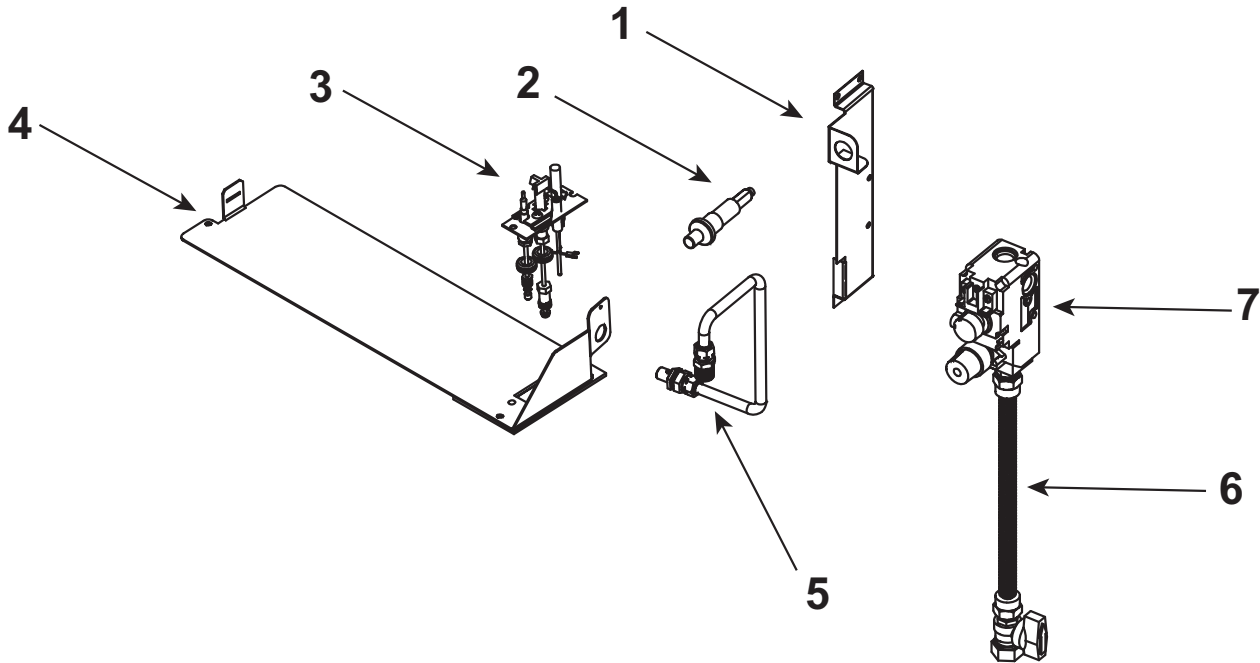

IMPORTANT: THIS IS DATED INFORMATION. The most current information is located on your dealers' VIP site. When ordering, supply serial and model numbers to ensure correct service parts.



AVAILABLE TO SHIP IN 24 HOURS

| ITEM | DESCRIPTION | SERIAL # | PART NUMBER | AVAILABLE TO SHIP IN 24 HOURS |
|------|--------------------------|----------|-------------|-------------------------------|
| 1 | Valve Bracket | | 2019-105 | |
| 2 | Piezo Ignitor | | 291-513 | Y |
| 3 | Pilot Assembly NG | | 530-510A | Y |
| | Pilot Assembly LP | | 530-511A | Y |
| 4 | Burner Drop Plate | | 2019-164 | |
| 5 | Flexible Gas Connector | | 567-301A | Y |
| 6 | Flex Ball Valve Assembly | | 302-320A | Y |
| 7 | Valve NG | | 060-522 | Y |
| | Valve LP | | 060-523 | Y |
| | Wiring Assembly | | 2020-059 | Y |
| | Gasket, Pilot (Bottom) | | 2019-161 | |
| | Gasket, Pilot (Top) | | 768-432 | |
| | Orifice NG (#36B) | | 567-801 | Y |
| | Orifice LP (#52B) | | 074-801 | Y |

1

Approvals and Codes

Appliance Certification

The Quadra-Fire appliance models discussed in this *Installers Guide* has been tested to certification standards and listed by the applicable laboratories.

| Certification | |
|--------------------|--------------------------------------|
| MODEL: | QVI-25FB |
| LABORATORY: | Underwriters Laboratories |
| TYPE: | Vented Gas Fireplace Heaters |
| STANDARD: | ANSI Z21.88-2002•CSA2.33-2002•UL307B |

Installation Codes

The appliance installation must conform to local codes. Before installing the appliance, consult the local building code agency to ensure that you are in compliance with all applicable codes, including permits and inspections.

In the absence of local codes, the appliance installation must conform to the National Fuel Gas Code ANSI Z223.1 (in the United States) or the CAN/CGA-B149 Installation Codes (in Canada). The appliance must be electrically grounded in accordance with local codes or, in the absence of local codes with the National Electric Code ANSI/NFPA No. 70 (in the United States), or to the CSA C22.1 Canadian Electric Code (in Canada).

These models may be installed in a bedroom or bed-sitting room in the U.S.A. and Canada.

High Altitude Installations

U.L. Listed gas appliances are tested and approved without requiring changes for elevations from 0 to 2,000 feet in the U. S. A. and in Canada.

When installing this appliance at an elevation above 2,000 feet, it may be necessary to decrease the input rating by changing the existing burner orifice to a smaller size. Input rate should be reduced by 4% for each 1000 feet above a 2000 foot elevation in the U.S.A. or 10% for elevations between 2000 and 4500 feet in Canada. If the heating value of the gas has been reduced, these rules do not apply. To identify the proper orifice size, check with the local gas utility.

If installing this appliance at an elevation above 4,500 feet (in Canada), check with local authorities.

2

Getting Started

Introducing the Village Collection Gas Appliances

The Village Collection direct vent gas appliances are designed to operate with all combustion air siphoned from outside of the building and all exhaust gases expelled to the outside.

The information contained in this *Installers Guide*, unless noted otherwise, applies to all models and gas control systems. Gas appliance diagrams, including the dimensions, are shown in this section.

Pre-install Preparation

This gas insert appliance and its components are tested and safe when installed in accordance with this *Installers Guide*. Report to your dealer any parts damaged in shipment, particularly the condition of the glass. **Do not install any unit with damaged, incomplete, or substitute parts.**

The vent system components and trim surrounds are shipped in separate packages. The gas logs are packaged separately and must be field installed.

Read all of the instructions before starting the installation. Follow these instructions carefully during the installation to ensure maximum safety and benefit. Failure to follow these instructions will void the owner's warranty and may present a fire hazard.

The Hearth & Home Technologies Warranty will be voided by, and Hearth & Home Technologies disclaims any responsibility for, the following actions:

- Installation of damaged appliance or vent system component.
- Modification of the appliance or direct vent system.
- Installation other than as instructed by Hearth & Home Technologies.
- Improper positioning of the gas logs or the glass door.
- Installation and/or use of any component part not manufactured and approved by Hearth & Home Technologies, not withstanding any independent testing laboratory or other party approval of such component part or accessory.

ANY SUCH ACTION MAY POSSIBLY CAUSE A FIRE HAZARD.

VENTING AND INSTALLATION

1. These gas inserts are designed for recessed installations into solid fuel masonry or factory built noncombustible appliances that have been installed in accordance with the National, Provincial, State and local building codes.
2. Minimum appliance opening requirements are shown in Figure 1 of this installation manual. The firebrick (refractory) can be removed from a factory built appliance in order to gain minimum gas insert opening requirements.
3. The metal floor of the solid fuel firebox may be removed to facilitate the installation of the insert. **CLEARANCE TO COMBUSTIBLE MATERIAL UNDER THE INSERT IS 1/4". YOU MUST USE THE LEVELING LEGS TO RAISE THE INSERT A MINIMUM OF 1/4" IF THE INSERT IS TO SIT ON COMBUSTIBLE MATERIAL.** The side walls and top structure of the firebox may not be altered with the exception of removable baffles and dampers. The original appliance may never be returned to solid fuel in this condition.

 **WARNING: A HEARTH OR HEARTH EXTENSION (IF PRESENT) MUST COMPLY WITH EITHER OF THE FOLLOWING: 1) THE SOLID-FUEL BURNING APPLIANCE MANUFACTURER'S SPECIFICATION, OR 2) LOCAL BUILDING CODES REQUIRED BY AUTHORITY HAVING JURISDICTION.**

 **WARNING: THE SOLID FUEL APPLIANCE HAS BEEN CONVERTED FOR USE WITH GAS ONLY AND CANNOT BE USED FOR BURNING WOOD OR SOLID FUELS UNLESS ALL ORIGINAL PARTS HAVE BEEN REPLACED AND THE APPLIANCE HAS BEEN REAPPROVED BY THE AUTHORITY HAVING JURISDICTION.**

4. The solid fuel appliance's flue damper must be fully locked in the open position or removed for installation.
5. The chimney must be cleaned and in good working order and constructed of noncombustible materials.
6. Make sure that all chimney cleanouts fit properly so air cannot leak into the chimney.
7. To assure top performance, safety and efficiency, inserts must be installed with an approved flue liner as per CAN/CGA B-149 or National Fuel Code ANSI Z223 and these instructions.
8. Install the insert without the trim surround and make all gas, venting, and electrical connections.
9. Install decorative trim surround. The surround is tested AND approved with this gas insert AND may cover existing air circulation vents or grills on the solid fuel appliance into which it is installed. Should the surround not cover all ventilation grill surfaces, the grill should be left open.

NOTE: DECORATIVE TRIM SURROUND HAS BEEN TESTED AND APPROVED TO COVER EXISTING AIR CIRCULATION VENTS OR GRILLS.

Only trim kit(s) supplied by the manufacturer shall be used in the installation of this appliance.

 **WARNING: Only the surround, as supplied, may be used to cover integral grills on the solid fuel burning appliance. No other components such as shrouds, sheet metal plates, etc. may be used to seal off vents. Remote grills or openings outside of the surround MUST NOT be covered or sealed.**

 **If the factory built appliance has no gas access holes provided, an access hole of 1" diameter (25mm) or less may be drilled through the lower sides or bottom of the combustion chamber in a proper workmanship like manner.**

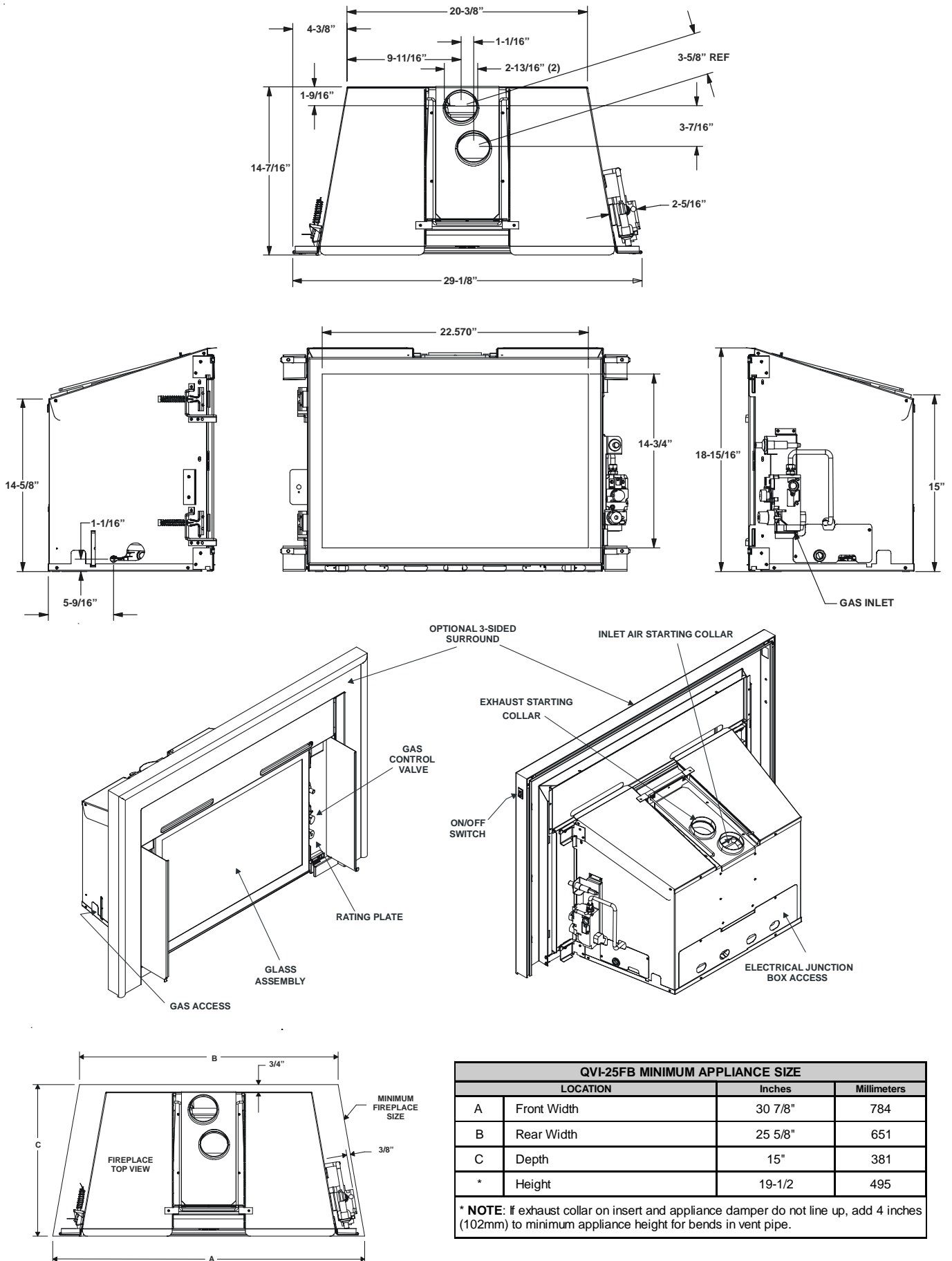

| QVI-25FB MINIMUM APPLIANCE SIZE | | | |
|---------------------------------|-------------|---------|-------------|
| LOCATION | | Inches | Millimeters |
| A | Front Width | 30 7/8" | 784 |
| B | Rear Width | 25 5/8" | 651 |
| C | Depth | 15" | 381 |
| * | Height | 19-1/2" | 495 |

* NOTE: If exhaust collar on insert and appliance damper do not line up, add 4 inches (102mm) to minimum appliance height for bends in vent pipe.

Figure 1. Diagram of insert and minimum appliance dimensions

3

Installing the Insert

Step 1. Installing the Vent System

Vent System Installation Precautions

Before starting installation of vent kits, the installer should read these instructions and the Vent Kit Instructions to ensure that a proper vent installation is completed.

Consult your local building codes before beginning the installation.

 **WARNING: THIS GAS INSERT AND VENT ASSEMBLY MUST BE VENTED DIRECTLY TO THE OUTSIDE AND MUST NEVER BE ATTACHED TO A CHIMNEY SERVING A SEPARATE SOLID FUEL BURNING APPLIANCE. EACH GAS APPLIANCE MUST USE A SEPARATE VENT SYSTEM. COMMON VENT SYSTEMS ARE PROHIBITED.**

Vent System Approvals

Appliance QVI-25FB is approved with vent termination kits LINK-DV-30, LINK-DV-30B, LINK-DV4-30 and LINK-DV4-30B as shown in Figures 3 & 4. Approved vent system terminations are labeled for identification. 3-inch diameter listed flexible aluminum and stainless steel gas vent is used for both the incoming combustion air and exhaust vent pipes. NO OTHER VENTING SYSTEMS OR COMPONENTS MAY BE USED. Detailed installation instructions are included with each vent termination kit and should be used in conjunction with this manual.

Horizontal Venting

The vent system on this model CANNOT be terminated horizontally.

Vertical Venting

The vent pipes **MUST** be connected to the proper collars on the unit **AND** the exhaust vent pipe **MUST** be connected to the termination cap or the unit will not operate. The combustion air vent pipe CAN be connected to the termination cap (LINK -DV30, LINK -DV30B) or it can terminate inside the chimney (LINK-DV4-30, LINK-DV4-30B). The bottom opening of the chimney must be sealed around the vent pipes if the combustion air vent is NOT connected to the termination cap. See Figure 3.

NOTE: The minimum vertical rise (exhaust vent) is 14 feet and the maximum vertical rise is 50 feet. These dimensions are measured from the starting collars of the unit to the end of the last section of vent pipe. See dimension V in Figure 3.

A vertical vent termination system installed on this model will require one (1) length of 3" stainless steel liner, one (1) length of 3-inch flexible vent pipe for the combustion air, one (1) length of 3-inch flexible vent pipe for the exhaust air, one (1) Termination Cap.

NOTE: The damper of the existing chimney may need to be removed to allow installation of the flexible-vent pipe.

 **WARNING: THIS APPLIANCE HAS BEEN CONVERTED FOR USE WITH A GAS APPLIANCE INSERT ONLY AND CANNOT BE USED FOR BURNING WOOD OR SOLID FUELS UNLESS ALL ORIGINAL PARTS HAVE BEEN REPLACED, AND THE FIRELACE REAPPROVED BY THE AUTHORITY HAVING JURISDICTION.**

NOTE: The above label, located in the instruction package, must be affixed to the existing appliance prior to installation.

For zero clearance factory built woodburning appliances, the use of kit LINK-ZC-ADB in place of the standard square flashing will allow you to mount the adaptor and cap on class "A" metal pipe.

Connecting the Vent Pipe

Install the 3" flexible vent pipe(s) down through the chimney. Secure the end of the flexible vent pipe for exhaust to the provided 3' section of stainless steel flexible vent pipe. A 3" collar is factory installed on one end for mating the two ends of flexible pipe.

 **WARNING: THE 3' SECTION OF STAINLESS STEEL FLEXIBLE PIPE MUST BE ATTACHED DIRECTLY TO THE EXHAUST COLLAR OF THE UNIT.**

Attach either 4' or 30' section of intake liner to the intake collar on the collar slide-plate using 3 screws. This assembly may be removed from the unit to aid installation. Slide insert into position, while pulling intake collar assembly towards the front of the unit. Slide the gas insert into place, and position any excess flexible vent pipe back up into the chimney. Secure the assembly in place using one screw to the center bracket (see Figure 4).

Attach the flashing and termination cap to the top of the flexible vent pipe and set the cap in place. See Figures 3 and 4.

CAUTION: TO AVOID DOWNDRAFTS AND/OR COLD AIR PROBLEMS, IT IS RECOMMENDED TO SEAL OFF THE AREA BETWEEN THE TERMINATION CAP AND THE TOP OF THE SOLID-FUEL CHIMNEY OPENING INTO WHICH THE VENT CAP HAS BEEN INSTALLED.

WHEN USING THE LINK-DV4-30 VENT SYSTEM, IT IS REQUIRED TO SEAL AROUND THE FLEXIBLE VENT PIPES IN THE DAMPER AREA. SEE FIGURE 3. USE FIBERGLASS INSULATION OR OTHER SUITABLE NON-COMBUSTIBLE MATERIAL.

WARNING: MAJOR U.S. BUILDING CODES SPECIFY MINIMUM CHIMNEY AND/OR VENT HEIGHT ABOVE THE ROOF TOP. THESE MINIMUM HEIGHTS ARE NECESSARY IN THE INTEREST OF SAFETY. SEE THE FOLLOWING DIAGRAM FOR MINIMUM HEIGHTS, PROVIDED THE TERMINATION CAP IS AT LEAST 2-FEET FROM A VERTICAL WALL AND 2-FEET BELOW A HORIZONTAL OVERHANG.

NOTE: This also pertains to vertical vent systems installed on the outside of the building.

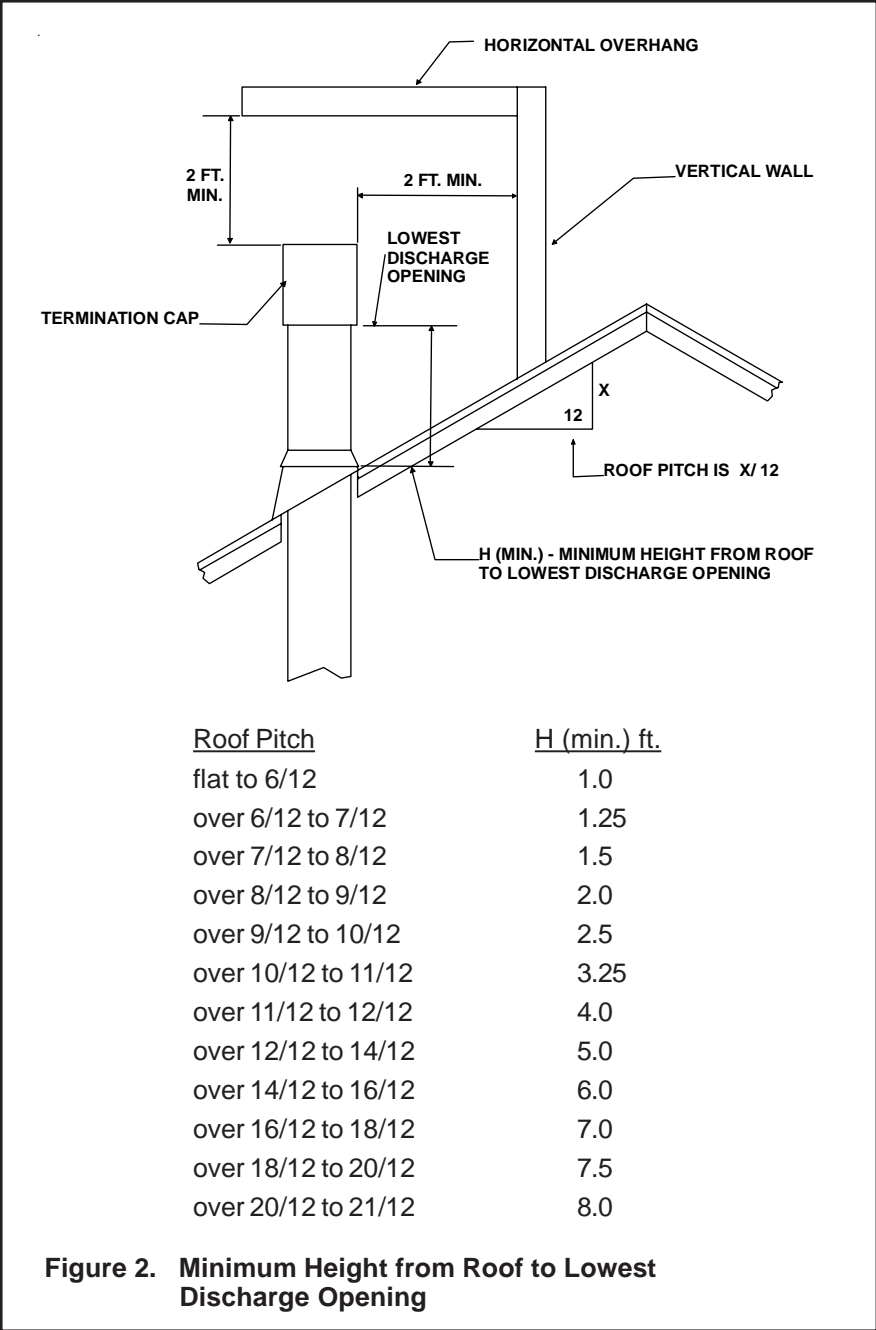

Figure 2. Minimum Height from Roof to Lowest Discharge Opening

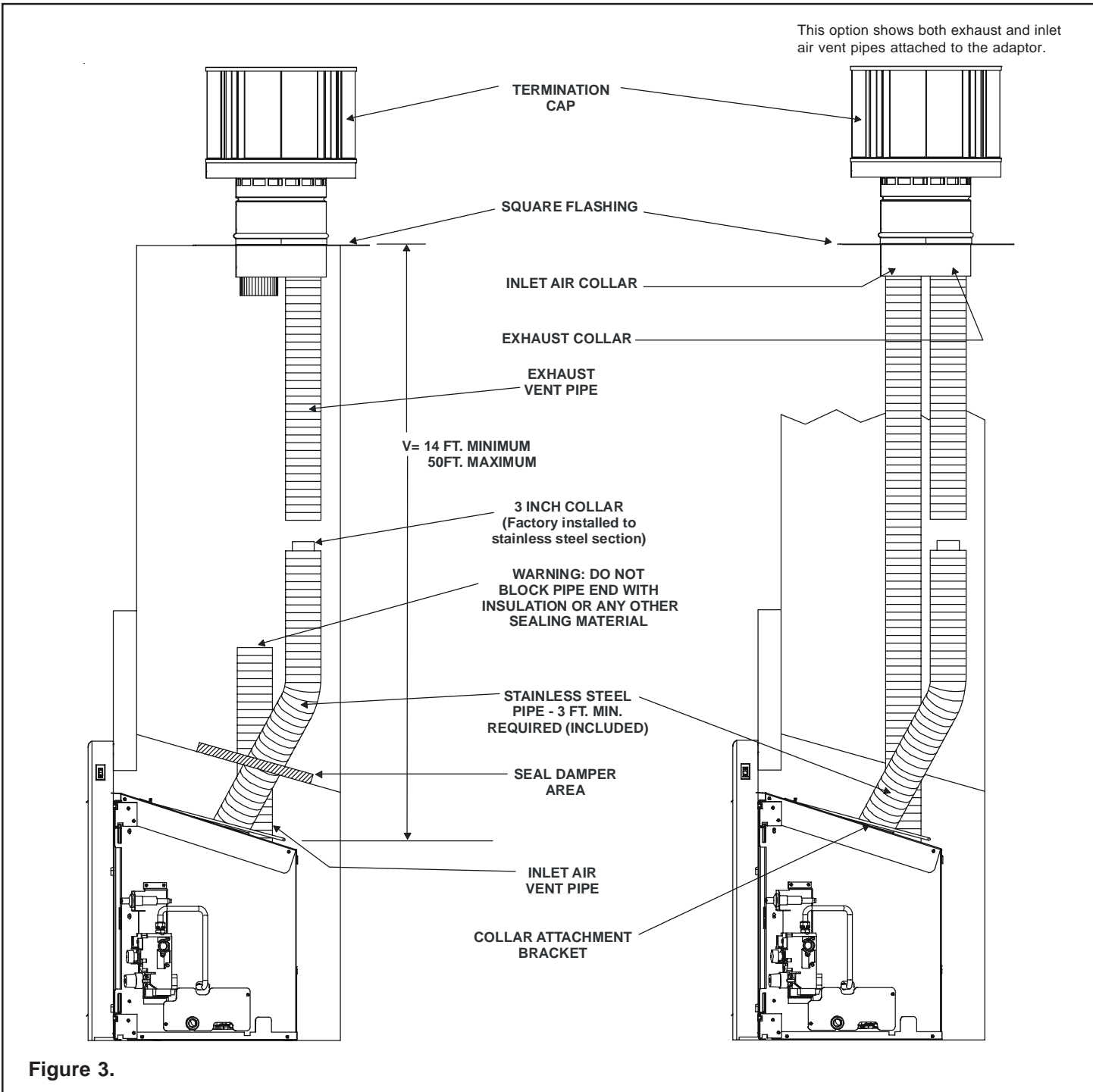
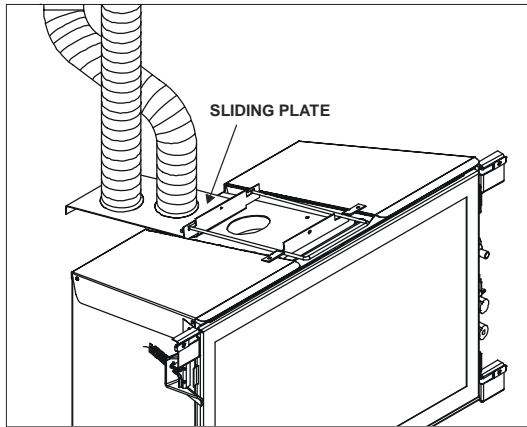
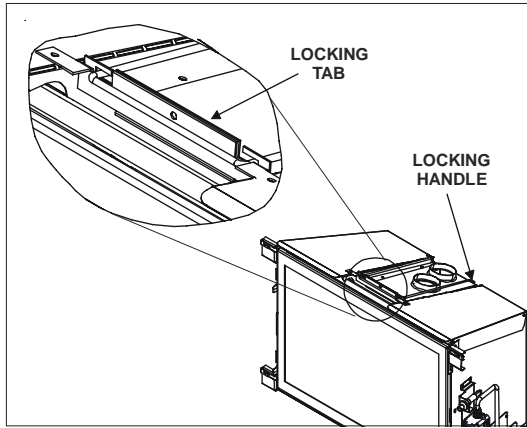

Figure 3.

! WARNING: THE EXHAUST VENT PIPE MUST ONLY BE CONNECTED TO THE EXHAUST STARTING COLLAR OF THE UNIT AND THE CENTER COLLAR OF THE TERMINATION CAP.

! A 3 FOOT SECTION OF STAINLESS STEEL FLEXIBLE LINER MUST BE ATTACHED DIRECTLY TO THE EXHAUST COLLAR ON COLLAR SLIDE PLATE.

! THE INLET AIR PIPE MUST ONLY BE CONNECTED TO THE INLET AIR COLLAR OF THE UNIT AND EITHER ATTACHED TO THE INLET AIR COLLAR OF THE TERMINATION CAP OR TERMINATED IN THE CHIMNEY.



Note: Inspect for exhaust collar gasket to insure positive exhaust seal.

ALTERNATIVE INSTALLATION FOR VENTING THROUGH WOOD-BURNING CLASS A PIPE

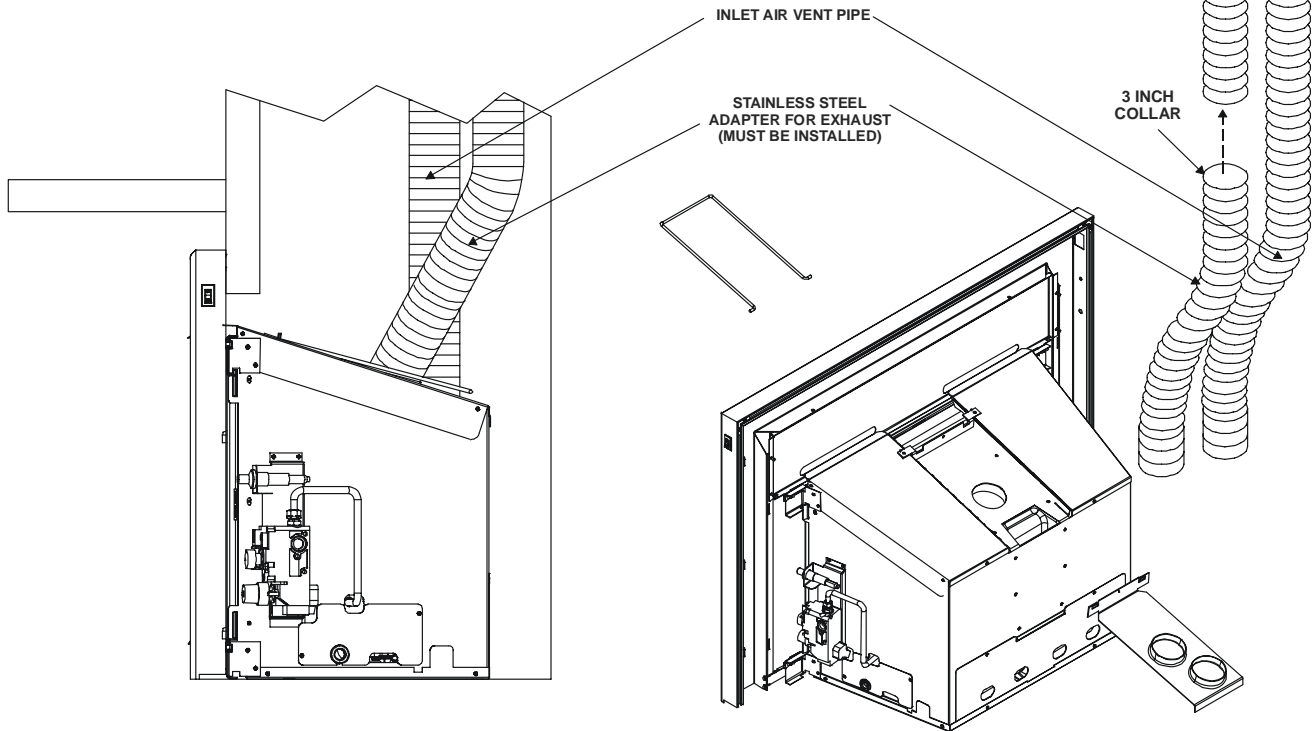
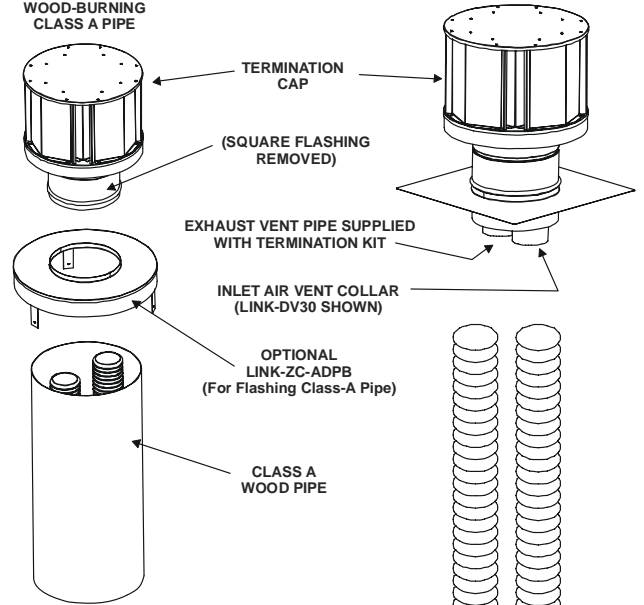
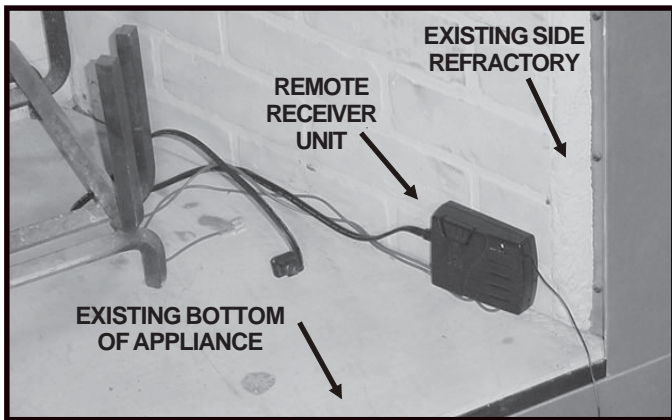

Figure 4. Typical configuration of vent liners.

Step 2. Positioning, Leveling, and Securing the Insert

Remote Control

The receiver for the remotes must be installed **BETWEEN** the base pan of the insert and the firebox of the wood-burning appliance (see photo below).



- Place the insert into position.
- Level the insert from side to side and from front to back. Use the leveling legs included with the manual bag if necessary to set each corner of the base.

Step 3. The Gas Control System



WARNING: THIS UNIT IS NOT FOR USE WITH SOLID FUEL.

This model uses a standing pilot ignition type of gas control system.

Standing Pilot Ignition System

This system includes millivolt control valve, standing pilot, thermopile/thermocouple flame sensor, and piezo ignitor.



WARNING: 110-120 VAC MUST NEVER BE CONNECTED TO A CONTROL VALVE IN A MILLIVOLT SYSTEM.

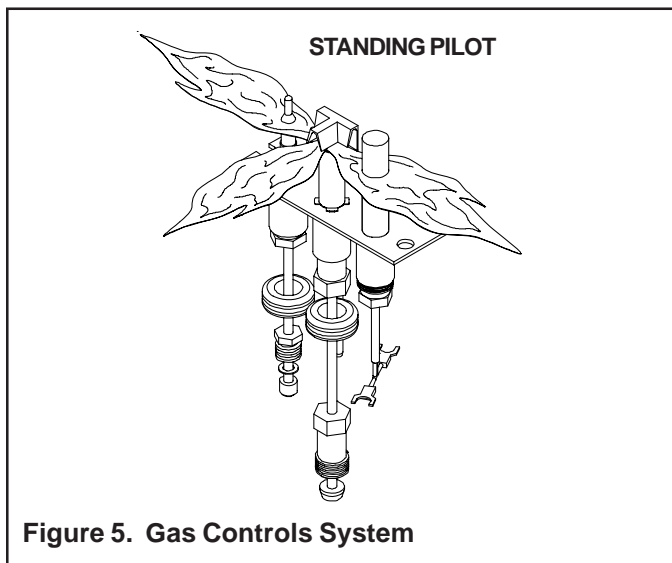

Figure 5. Gas Controls System

Step 4. The Gas Supply Line

NOTE: Have the gas supply line installed in accordance with local building codes by a qualified installer approved and/or licensed as required by the locality. (In the Commonwealth of Massachusetts installation must be performed by a licensed plumber or gas fitter).

NOTE: Before the first firing of the appliance, the gas supply line should be purged of any trapped air.

NOTE: Consult local building codes to properly size the gas supply line leading to the 1/2 inch (13 mm) hook-up at the unit.

This gas appliance is designed to accept a 1/2 inch (13 mm) gas supply line. To install the gas supply line:

- A listed (and Commonwealth of Massachusetts approved) 1/2 inch (13mm) tee-handle manual shut-off valve and a listed flexible gas connector are connected to the 1/2 inch (13mm) inlet of the control valve. **NOTE:** If substituting for these components, please consult local codes for compliance.
- Locate the gas line access hole in the outer casing of the appliance.
- Insert the gas supply line through the gas line hole and connect it to the shut-off valve.
- When attaching the pipe, support the control so that the lines are not bent or torn.
- After the gas line installation is complete, all connections must be tightened and checked for leaks with a commercially-available, non-corrosive leak check solution. Be sure to rinse off all leak check solution following testing.



WARNING: DO NOT USE AN OPEN FLAME TO CHECK FOR GAS LEAKS.

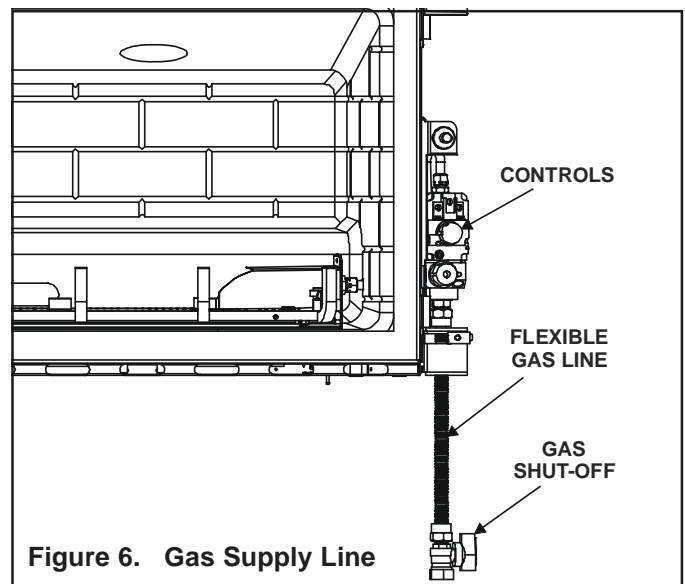

Figure 6. Gas Supply Line

Step 5. Gas Pressure Requirements

Pressure requirements for these gas appliances are shown in the table below.

| Pressure | Natural Gas | Propane |
|----------------------------|------------------|------------------|
| Minimum Inlet Pressure | 5.0 inches w.c. | 11.0 inches w.c. |
| Maximum Inlet Gas Pressure | 14.0 inches w.c. | 14.0 inches w.c. |
| Manifold Pressure | 3.5 inches w.c. | 10.0 inches w.c. |

Inlet and outlet pressure taps are provided on the front face of the gas control for a test gauge connection to measure the manifold pressure. Use a small flat blade screwdriver to crack open the screw in the center of the tap. Position a rubber hose over the tap to obtain the pressure reading.

THE APPLIANCE AND ITS INDIVIDUAL SHUT-OFF VALVE MUST BE DISCONNECTED FROM THE GAS SUPPLY PIPING SYSTEM AND ISOLATED DURING ANY PRESSURE TESTING OF THE SYSTEM AT TEST PRESSURES EQUAL TO OR IN EXCESS OF ONE-HALF (1/2) PSIG (3.5 KPA).

Step 6. Wiring the Appliance

NOTE: Electrical wiring must be installed by a licensed electrician.

CAUTION: DISCONNECT REMOTE CONTROLS IF ABSENT FOR EXTENDED TIME PERIODS. THIS WILL PREVENT ACCIDENTAL APPLIANCE OPERATION.

For Standing Pilot Ignition Wiring Appliance Requirements

- This appliance **DOES NOT** require 110-120 VAC to operate, unless using an optional remote or blower.

WARNING: DO NOT CONNECT 110-120 VAC TO THE GAS CONTROL VALVE OR THE WALL SWITCH OR THE APPLIANCE WILL MALFUNCTION AND THE VALVE WILL BE DESTROYED.

Wall Switch

Position the wall switch in the desired position on the wall. An assembly of 18 ft of 20 AWG is provided with the appliance to connect the wall switch to the appliance. Instead of the supplied assembly, wire with a length of 25 ft or less and a gauge of 20 AWG through 14 AWG is acceptable. The wire needs a jacket with a temperature rating of 140°F (60°C) or higher. At the appliance connect the wire to the ON/OFF switch pigtails.

CAUTION: LABEL ALL WIRES PRIOR TO DISCONNECTION WHEN SERVICING CONTROLS. WIRING ERRORS CAN CAUSE IMPROPER AND DANGEROUS OPERATION. VERIFY PROPER OPERATION AFTER SERVICING.

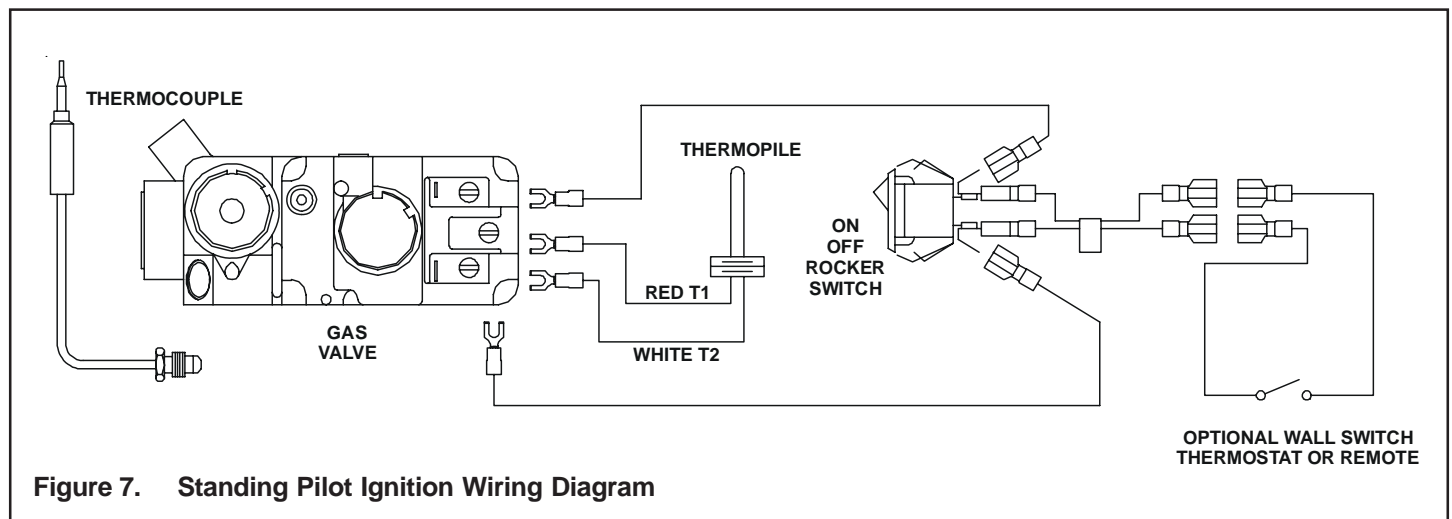

Figure 7. Standing Pilot Ignition Wiring Diagram

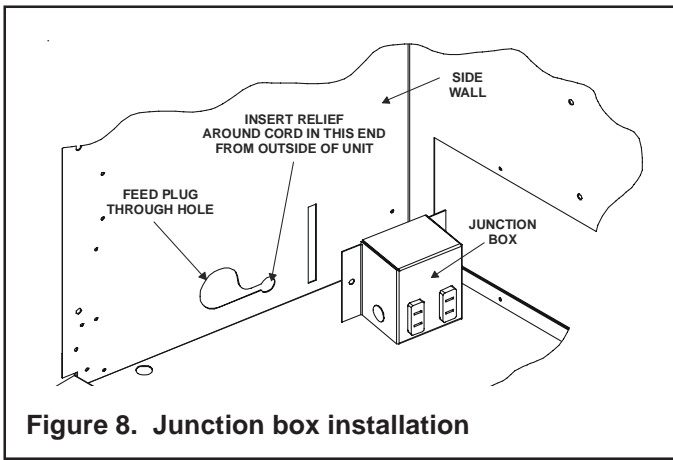

Figure 8. Junction box installation

Optional Accessories

Use of the electrical junction box provided is required if using a blower or remote. Plug the cord into a convenient outlet. An electrician may install an outlet box inside the appliance. Place the outlet in the lower, back corner of the appliance. Make sure fan doesn't touch back wall.

WARNING: USE OF THE CORD SUPPLIED WITH THE ELECTRICAL JUNCTION BOX IS REQUIRED.

Fan Option

This product accepts an optional blower GFK-160A. Installation of this blower requires 110 VAC power supplied to the

electrical junction box. The optional blower GFK-160A CAN NOT be used when using operable glass doors.

On units already installed removal of decorative front, surround and gas insert is required.

- Detach flexible liner from back of unit.
- Remove the four screws on the coverplate (see Figure 10).
- Bend up the tabs on the base pan (see Figure 9).
- Place the blower in between the bend up tabs.
- Install and wire the blower per instructions shipped with the fan. Refer to Figure 9 for placement of the temp switch bracket and mounting stud.
- The ground wire of the fan can clip on the side of the base pan.
- Attach rubber grommets to cover plate as shown (included in manual bag assembly).
- Reinstall the cover plate on the unit. Make sure the fan does not make contact with the back wall.

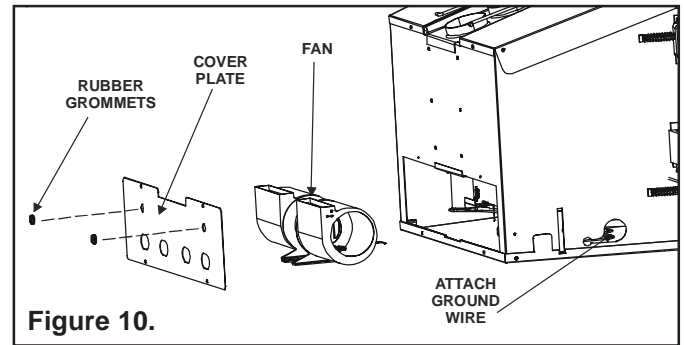

Figure 10.

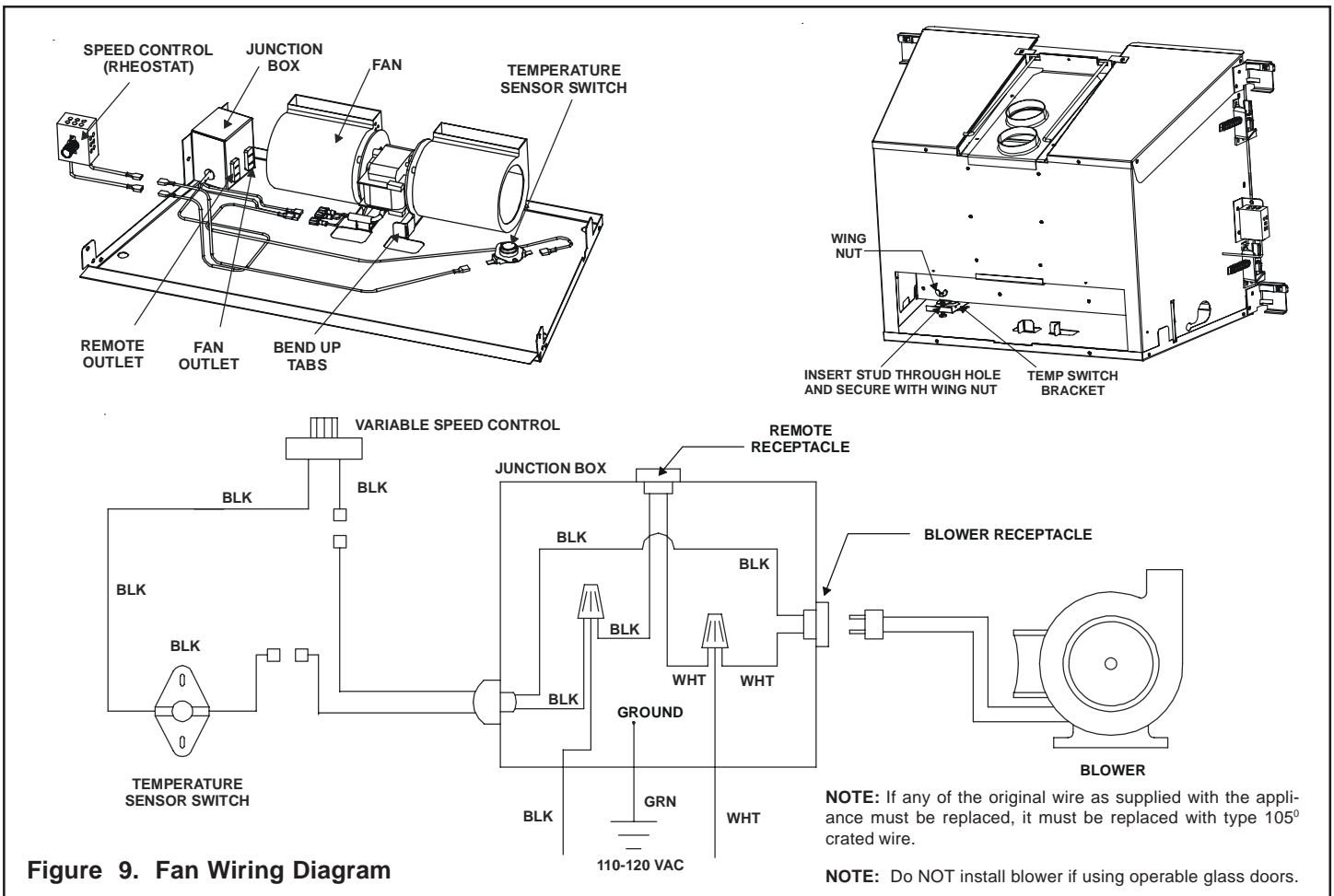

Figure 9. Fan Wiring Diagram

NOTE: If any of the original wire as supplied with the appliance must be replaced, it must be replaced with type 105⁹ crated wire.

NOTE: Do NOT install blower if using operable glass doors.

Step 7. Installing Logs and Ember Material

Shutter Settings

| Burner | NG | LP |
|----------|-------|-----------|
| QVI-25FB | 7/16" | Full Open |

Removing the Glass

Open access panels located on either side of the glass door. Pull and release attachment latches at left of glass door out and away from appliance. To reinstall glass, hook right side tabs behind attachment brackets (right), swing glass door into position, and secure by latching the tabs on left side (see Figure 11).

Positioning the Logs

The logs have been packaged separately. Refer to the installation instructions that accompany this manual. **Save the log instructions with this manual.**

If sooting occurs, the logs might need to be repositioned slightly to avoid excessive flame impingement.

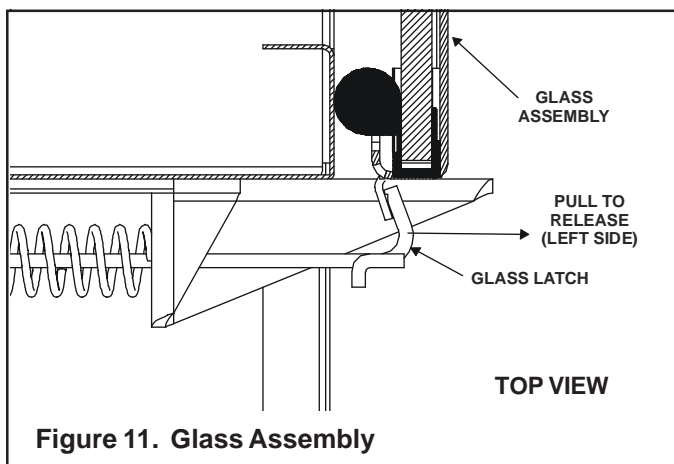

Placing the Ember Material

Two separate bags of ember material are shipped with this gas appliance. The bag labeled Glowing Ember (050-721) is standard glowing ember material. To place the ember material:

- Remove the glass door from the unit.
- Place a dime size piece of **GLOWING EMBER** material near port holes in burner top (see Figure 12).
- Space dime size ember pieces about a 1/2 inch apart. Never press embers into burner ports. **DO NOT** cover burner ports. Place dime size pieces around front and sides of burner pan.
- Save the remaining ember materials for use during appliance servicing. The embers provided are sufficient for 2 to 4 applications.
- Place **MYSTIC EMBERS** over burner surface and around base of the burner, **DO NOT** cover any burner port holes. Can be used on floor of firebox for a realistic ash-bed.
- Replace the glass door on the appliance.
- Re-install and latch the decorative front.

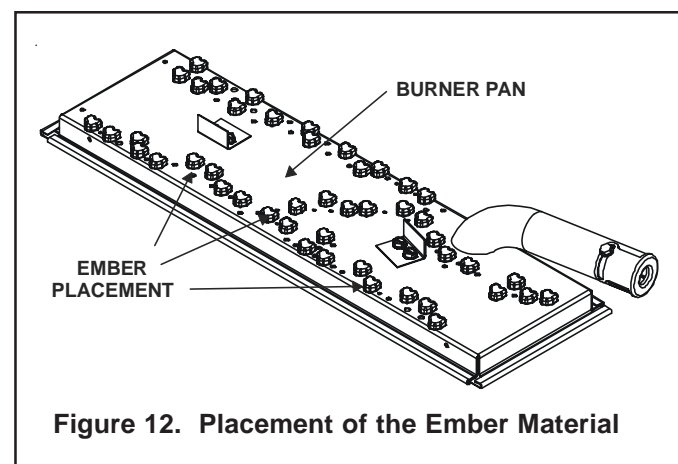

Step 8. Installing Trim Surrounds

Combustible materials **MUST NEVER** overlap onto the front face.

1. Find the coiled low voltage wires attached to outer right side of the insert (see Figure 13).
2. Disconnect the ON/OFF switch from the low voltage wire leads, and insert the ON/OFF switch through the hole at the upper right corner of the surround - it will be retained in the hole.

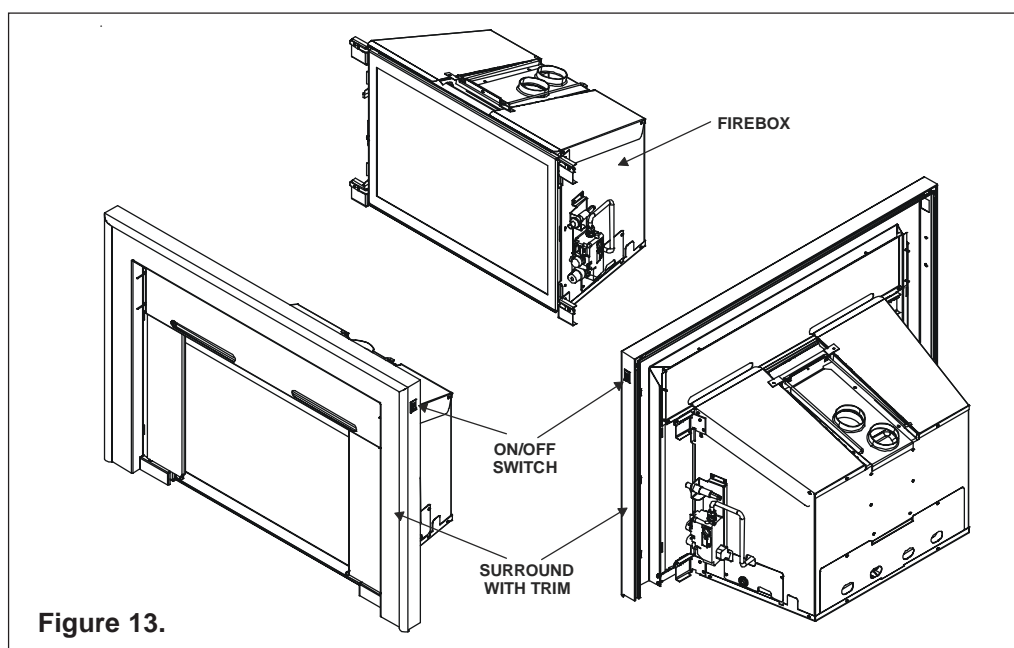

3. Attach the low voltage wires to the ON/OFF switch located on the front of surround.
4. Attach surround assembly by securing four corners with screws provided (see Figure 13.) Reposition the appliance if necessary. Refer to surround instructions provided with the decorative surround.

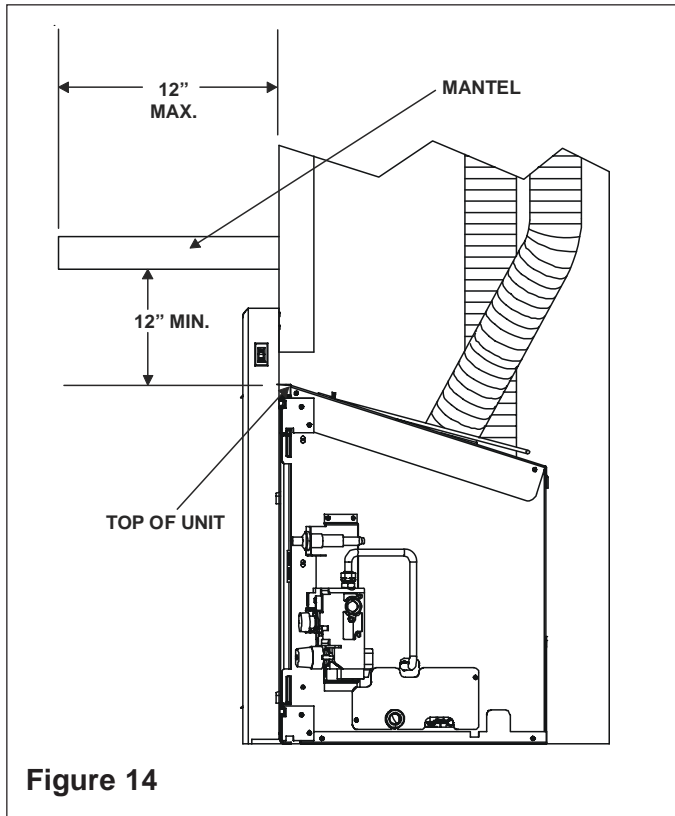

Figure 14 shows the minimum vertical and corresponding maximum horizontal dimensions of mantels or other combustible projections above the gas appliance.

Step 9. Before Lighting the Appliance

Before lighting the appliance, be sure to do the following:

Remove all paperwork from the appliance.

Review safety warnings and cautions

- Read the **Safety and Warning Information** section at the beginning of this *Installers Guide*.

Double-check for gas leaks

- Before lighting the appliance, double-check the unit for possible gas leaks.

Double-check vent terminations for obstructions.

- Before lighting the appliance, double-check the unit for possible obstructions that could be blocking the vent terminations.

Double-check for faulty components

- Any component that is found to be faulty **MUST BE** replaced with an approved component. Tampering with the appliance components is **DANGEROUS** and voids all warranties.

A small amount of air will be in the gas supply lines. When first lighting the appliance, it will take a few minutes for the lines to purge themselves of this air. Once the purging is complete, the appliance will light and will operate normally.

Subsequent lightings of the appliance will not require this purging of air from the gas supply lines, **unless the gas valve has been turned to the OFF position**, in which case the air would have to be purged.

NOTE: The appliance should be run 3 to 4 hours on the initial start-up. Turn it off and let it cool completely. Remove and clean the glass. Replace the glass and run the appliance for an additional 8 hours. This will help to cure the products used in the paint and logs.

Step 10. Lighting the Appliance

You've reviewed all safety warnings, you've checked the appliance for gas leaks, you know the vent system is

unobstructed, and you've checked for faulty components. Now you're ready to light the appliance.

FOR YOUR SAFETY READ BEFORE LIGHTING

WARNING: IF YOU DO NOT FOLLOW THESE INSTRUCTIONS EXACTLY, A FIRE OR EXPLOSION MAY RESULT CAUSING PROPERTY DAMAGE, PERSONAL INJURY, OR LOSS OF LIFE.



STANDING PILOT IGNITION

- A. This appliance (standing pilot version) has a pilot that must be lighted by hand. When lighting the pilot, follow these instructions exactly.
- B. BEFORE LIGHTING smell all around the appliance area for gas. Be sure to smell next to the floor because some gas is heavier than air and will settle to the floor.

WHAT TO DO IF YOU SMELL GAS



- Do not try to light any appliance.
 - Do not touch any electric switch; do not use any phone in your building.
 - Immediately call your gas supplier from a neighbor's phone. Follow the gas supplier's instructions.
 - If you cannot reach your gas supplier, call the fire department.
- C. Use only your hand to push in or turn the gas control knob. Never use tools. If the knob will not push in or turn by hand, don't try to repair it, call a qualified service technician. Force or attempted repair may result in a fire or explosion.
 - D. Do not use this appliance if any part has been under water. Immediately call a qualified service technician to inspect the appliance and to replace any part of the control system and any gas control which has been under water.

LIGHTING INSTRUCTIONS STANDING PILOT CONTROLS

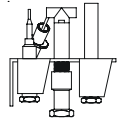
1. To access controls, open the lower grille.
2. Turn the gas control valve knob to the OFF position. To do this, you must turn the knob clockwise  to the PILOT position, and then press in and continue turning clockwise  to the OFF position. **NOTE:** Knob cannot be turned from "PILOT" to "OFF" unless knob is pushed in slightly. Do not force.
3. WAIT AT LEAST FIVE (5) MINUTES TO CLEAR OUT ANY GAS. If you have unsuccessfully tried to light the appliance, wait longer, especially if you are using LP gas. Then smell for gas, including near the floor. If you then smell gas, **STOP!** Follow "B" in the safety information on previous page. If you don't smell gas, go to the next step.
4. The pilot should not require accessing for lighting purposes. The pilot is located inside the combustion chamber. If it is necessary to access the pilot, remove the trim door and glass door.



THERMOCOUPLE PILOT THERMOPILE

5. To put the control in the PILOT position, turn the control knob counter-clockwise  to the PILOT position.
6. To light the pilot press the control knob and then press the red or black piezo button once every second. The piezo makes a clicking sound. It may be necessary to repeat this step. If the pilot does not light after 10 seconds, go back to step 2. The control knob should be held down for a MINUTE after pilot ignition.
 - If the control knob does not pop out when released, **STOP!** Shut off the gas supply to the appliance control valve, and **IMMEDIATELY** call your service technician or gas supplier.
 - If the pilot will not stay lit after two tries, turn the control knob to the "OFF" position and call your service technician or gas supplier.
7. After the pilot has been lit, the burner can be turned on by turning the knob counter-clockwise  to the "ON" position.
8. Set the ON/OFF switch to the "ON" position.
9. Close the lower grille.

TO TURN OFF GAS APPLIANCE

1. Open the lower grille.
2. Set ON/OFF switch to "OFF".
3. Turn the valve control knob clockwise  to the "Pilot" position, then depress knob and continue turning to "OFF" position.
4. Close the lower grille.

When you light your appliance, you may notice:

This gas appliance produces heat which does have an associated odor or smell. If you feel this odor is excessive it may require the initial 3-4 hour continuous burn on high followed by a second burn up to 12 hours to fully drive off any odor from paint and lubricants used in the manufacturing process.

During this break-in period it is recommended that some windows in the house be opened for air circulation. This will help avoid setting off smoke detectors, and help eliminate any odors associated with the appliance's initial burning.

Additionally, for the first few minutes after each lighting, vapor may condense and fog the glass and flames may be blue. After a few minutes this moisture will disappear and within 15-30 minutes the flames should become yellow.

Noise caused by metal expanding and contracting as it heats up and cools down, similar to the sound produced by a furnace or heating duct. This noise does not affect the operation or longevity of your appliance.

After the Installation



LEAVE THIS INSTALLATION MANUAL WITH THE APPLIANCE FOR FUTURE REFERENCE.

4

Maintaining and Servicing Your Appliance

Appliance Maintenance

Although the frequency of servicing and maintenance will depend on use and the type of installation, you should have a qualified service technician perform an appliance check-up at the beginning of each heating season. See the table below for specific guidelines regarding each appliance maintenance task.

IMPORTANT: TURN OFF THE GAS BEFORE SERVICING YOUR APPLIANCE.

Replacing old ember material

Frequency: Once annually, during the checkup.

By: Qualified service technician.

Task: Brush away loose ember material near the burner. Replace old ember material with new dime-size and shape pieces of Golden Ember (DE-93) and Glowing Ember (050-721). New ember material should be placed alternately on top of the burner - a layer of Golden Ember, a layer of Glowing Ember, and so on. Save the remaining ember material and repeat this procedure at your next servicing. For more information, see **Placing Ember Material**.

Cleaning Burner and Controls

Frequency: Once annually.

By: Qualified service technician.

Task: Brush or vacuum the control compartment, appliance logs and burner areas surrounding the logs.

Checking Flame Patterns, Flame Height

Frequency: Periodically.

By: Qualified service technician/Home owner.

Task: Make a visual check of your appliance's flame patterns. Make sure the flames are steady - not lifting or floating. See Figure 15. The thermopile/thermocouple (standing pilot) tips should be covered with flame. See Figure 5.

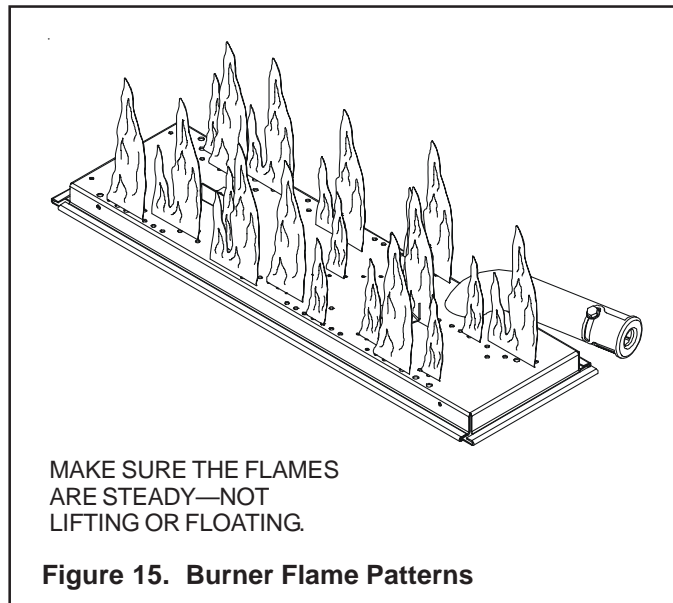

Checking Vent System

Frequency: Before initial use and at least annually thereafter, more frequently if possible.

By: Qualified service technician/Home owner.

Task: Inspect the external vent cap on a regular basis to ensure that no debris is interfering with the flow of air. Inspect entire vent system for proper function.

Cleaning Glass Door

Frequency: After the first 3 to 4 hours of use. As necessary after initial cleaning.

By: Home owner.

Task: Remove and clean glass after the first 3 to 4 hours of use. After the initial cleaning, clean as necessary, particularly after adding new ember (flame colorant) material. Film deposits on the inside of the glass door should be cleaned off using a household glass cleaner. **NOTE: DO NOT handle or attempt to clean the door when it is hot and DO NOT use abrasive cleaners.**

5

Troubleshooting

With proper installation, operation, and maintenance your gas appliance will provide years of trouble-free service. If you do experience a problem, this troubleshooting guide will assist a qualified service person in the diagnosis of a problem and the corrective action to be taken. This troubleshooting guide can only be used by a qualified service technician.

| Symptom | Possible Cause | Corrective Action |
|---|--|--|
| 1. After repeated triggering of the red or black piezo button, the spark ignitor will not light the pilot. | a. Defective ignitor. | Check the spark at the electrode and pilot. If no spark and electrode wire is properly connected, replace the ignitor. |
| | b. Defective pilot or misaligned electrode (spark at electrode). | Using match, light the pilot. If the pilot lights, turn off the pilot and trigger the red or black piezo button again. If the pilot lights, an improper gas/air mixture caused the bad lighting and a longer purge period is recommended. If the pilot will not light, ensure the the gap at the electrode and pilot is one-eighth (1/8) inch to have a strong spark. If the gap is OK, replace the pilot. |
| | c. No gas or low gas pressure. | Check the remote shut-off valvess from the fireplace. Usually, there is a valve near the gas main. There can be more than one (1) valve between the fireplace and the main. |
| | d. No LP in tank. | Check the LP (propane) tank. You may be out of fuel. |
| 2. The pilot will not stay lit after carefully following the lighting instructions. | a. Defective thermocouple. | Check that the pilot flame impinges on the thermocouple. Clean and/or adjust the pilot for maximum flame impingement. Ensure that the thermocouple connection at the gas valve is fully inserted and tight (hand tighten plus 1/4 turn). Disconnect the thermocouple from the valve, place one millivolt meter lead wire on the tip of the thermcouple and the other meter lead wire on the thermocouple copper lead. Start the pilot and hold the valve knob in. If the millivolt reading is less than 15mV, replace the thermocouple. |
| | b. Defective valve. | If the thermocouple is producing more than 15 millivolts, replace faulty valve. |
| 3. The pilot is burning, there is no gas burner, the valve knob is in the ON position, and the ON/OFF switch is in the ON position. | a. ON/OFF switch or wires defective. | Check the ON/OFF switch and wires for proper connections. Place the jumper wires across the terminals at the switch. If the burner comes on, replace the defective switch. If the switch is OK, place the jumper wires across the switch wires at the gas valve. If the burner comes on, the wires are faulty or connections are bad. |
| | b. Thermopile may not be generating sufficient millivoltage. | If the pilot flame is not close enough physically to the thermopile, adjust the pilot flame. Be sure the wire connections from the thermopile at the gas valve terminals are tight and that the thermopile is fully inserted into the pilot bracket. Check the thermopile with a millivolt meter. Take the reading at TH-TP&TP terminals of the gas valve. The meter should read 325 millivolts minimum, while holding the valve knob depressed in the pilot position, with the pilot lit, and the ON/OFF switch in the OFF position. Replace the faulty thermopile if the reading is below the specified minimum. With the pilot in the ON position, disconnect the thermopile leads from the valve. Take a reading at the thermopile leads. The reading should be 325 millivolts minimum. Replace the thermopile if the reading is below the minimum. |
| | c. Defective valve. | Turn the valve knob to the ON position. Place the ON/OFF switch in the ON position. Check the millivolt meter a the thermopile terminals. The millivolt meter should read greater than 125mV. If the reading is acceptable, and if the burner does not come on, replace the gas valve. |
| | d. Plugged burner orifice. | Check the burner orifice for stoppage. Remove stoppage. |
| | e. Wall switch or wires are defective. | Follow the corrective action in Symptom and Possible Cause 1.a above. Check the switch and wiring. Replace where defective. |

Troubleshooting *(continued)*

| Symptom | Possible Cause | Corrective Action |
|---|---|---|
| 4. Frequent pilot outage problem. | a. Pilot flame may be too high or too low, or blowing (high), causing pilot safety to drop out. | Clean and adjust the pilot flame for maximum flame impingement on thermocouple. Follow lighting instructions carefully. |
| 5. The pilot and main burner extinguish while in operation. | a. No LP in tank. | Check the LP (propane) tank. Refill the fuel tank. |
| | b. Inner vent pipe leaking exhaust gases back into the system. | Check for gas leaks. |
| | c. Glass too loose and air tight packet leaks in corners after usage. | Tighten the corner. |
| | d. Bad thermopile or thermocouple. | Replace if necessary. |
| | e. Improper vent cap installation. | Check for proper installation and freedom from debris or blockage. |
| 6. Glass soots. | a. Flame impingement. | Adjust the log set so that the flame does not excessively impinge on it. |
| | b. Improper venturi setting. | Adjust the air shutter at the base of the burner. |
| | c. Debris around venturi. | Inspect the opening at the base of the burner. NO MATERIAL SHOULD BE PLACED IN THIS OPENING. |
| 7. Flame burns blue and lifts off burner. | a. Insufficient oxygen being supplied. | <p>Ensure that the vent cap is installed properly and free of debris. Ensure that the vent system joints are tight and have no leaks.</p> <p>Ensure that no debris has been placed at the base of, or in the area of the air holes in the center of the base pan beneath the burner.</p> <p>Ensure that the glass is tightened properly on the unit, particularly on top corners.</p> |

Lifetime Warranty

LIMITED LIFETIME WARRANTY

The Hearth & Home Technologies limited Lifetime Warranty guarantees that the following components will work as designed for the lifetime of the stove or Hearth & Home Technologies will repair or replace them. These items include but are not limited to steel and cast iron components, all gas burners, gas logs, combustion chambers, heat exchanger systems, stainless steel firebox components, plating, doors, glass damaged by thermal breakage, steel baffle supports, steel and ceramic baffles and manifold tubes. Labor is for the first five years.

THREE YEAR WARRANTY

Our EZ Clean firepots are covered under Hearth & Home Technologies three-year warranty program. Labor is for 3 years.

TWO YEAR WARRANTY

All electrical components such as but not limited to blowers, wiring, vacuum switches, speed controls, control boxes, thermodisc switches, pilot assembly, gas valves, thermostats and remotes are covered under Hearth & Home Technologies two-year warranty program.

ONE YEAR WARRANTY

Porcelain finishes are warranted against manufacturer defects for one year. Labor to repair or replace these parts is covered for one year, reimbursed per our warranty service fee schedule.

CONDITIONS

This warranty is nontransferable and is made to the original retail purchaser only provided that the purchase was made through an authorized dealer of Hearth & Home Technologies It must be installed and operated at all times in accordance with the Installation and Operating Instructions furnished with this product, as well as any applicable local and national codes. Any alteration, willful abuse, accident, or misuse of the product shall nullify this warranty.

Labor to repair or replace items covered under the limited Lifetime Warranty will be covered for the first five years per our warranty service fee reimbursement schedule. Parts covered under the limited Lifetime Warranty will be covered for the lifetime of the appliance up to a maximum of ten (10) years after Hearth & Home Technologies discontinues the model and two (2) years for optional accessories. Adjustments, regular maintenance, cleaning and temporary repairs do not qualify for a service call fee and will not be covered. The replacement of consumer replaceable items and installation of upgraded component parts do not qualify for a service call fee, and will not be covered.

This limited Lifetime Warranty does not extend to or include surface finish on the appliance, door gasketing, glass gasketing, firebrick, kaowool or other ceramic insulating materials. It does not cover installation or operational-related problems such as overfiring, use of corrosive driftwood, downdrafts or spillage caused by environmental conditions, nearby trees, buildings, hilltops, mountains, inadequate venting or ventilation, excessive offsets, or negative air pressures caused by mechanical systems such as furnaces, fans, clothes dryers, etc.

Any installation, construction, transportation, or other related costs or expenses arising from defective part(s), repair, replacement, etc., will not be covered by this warranty, nor will Hearth & Home Technologies assume responsibility for them. Further, Hearth & Home Technologies will not be responsible for any incidental, indirect, or consequential damages, except as results in damage to the interior or exterior of the building in which this appliance is installed. This limited Lifetime Warranty does not apply to the venting components, hearth components or other accessories used in conjunction with the installation of this product not manufactured by Hearth & Home Technologies

This warranty is void if the stove has been over fired or operated in atmospheres contaminated by chlorine, fluorine, or other damaging chemicals, the stove is subjected to prolonged periods of dampness or condensation, or there is any damage to the stove or other components due to water or weather damage which is the result of, but not limited to, improper chimney or venting installation. Hearth & Home Technologies may, at its discretion, fully discharge all obligations with respect to this warranty by either repairing or replacing the unit, or refunding the wholesale price of the defective part(s).

This limited Lifetime Warranty is effective on all appliances sold after May 1, 2002 and supersedes any and all warranties currently in existence.

