

**Model:**  
**QV36DB-A**

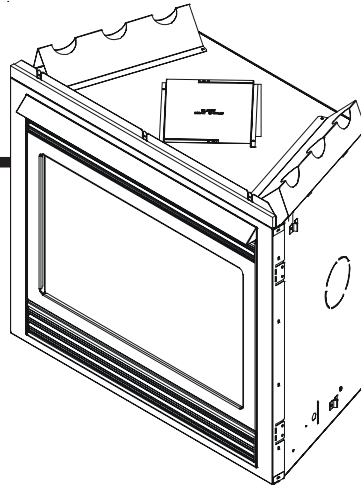

**CAUTION**



**DO NOT DISCARD THIS MANUAL**

- Important operating and maintenance instructions included.
- Read, understand and follow these instructions for safe installation and operation.
- Leave this manual with party responsible for use and operation.

**⚠ WARNING: If the information in these instructions is not followed exactly, a fire or explosion may result causing property damage, personal injury, or death.**

- Do not store or use gasoline or other flammable vapors and liquids in the vicinity of this or any other appliance.
- **What to do if you smell gas**
  - Do not try to light any appliance
  - Do not touch any electrical switch. Do not use any phone in your building.
  - Immediately call your gas supplier from a neighbor's phone. Follow the gas supplier's instructions.
  - If you cannot reach your gas supplier, call the fire department.
- Installation and service must be performed by a qualified installer, service agency, or the gas supplier.

This appliance may be installed as an OEM installation in manufactured home (USA only) or mobile home and must be installed in accordance with the manufacturer's instructions and the manufactured home construction and safety standard, *Title 24 CFR, Part 3280* or *Standard for Installation in Mobile Homes, CAN/CSA Z240MH*.

*This appliance is only for use with the type(s) of gas indicated on the rating plate.*

**⚠ WARNING**



**HOT SURFACES!**

Glass and other surfaces are hot during operation AND cool down.

**Hot glass will cause burns.**

- **DO NOT** touch glass until it is cooled
- **NEVER** allow children to touch glass
- Keep children away
- **CAREFULLY SUPERVISE** children in same room as fireplace.
- Alert children and adults to hazards of high temperatures.

**High temperatures may ignite clothing or other flammable materials.**

- Keep clothing, furniture, draperies and other flammable materials away.

***This appliance has been supplied with an integral barrier to prevent direct contact with the fixed glass panel. DO NOT operate the appliance with the barrier removed.***

Contact your dealer or Hearth & Home Technologies if the barrier is not present or help is needed to properly install one.

In the Commonwealth of Massachusetts installation must be performed by a licensed plumber or gas fitter.

See Table of Contents for location of additional Commonwealth of Massachusetts requirements.



Installation and service of this appliance should be performed by qualified personnel. Hearth & Home Technologies suggests NFI certified or factory-trained professionals, or technicians supervised by an NFI certified professional.

# SAFETY AND WARNING INFORMATION

 **READ** and **UNDERSTAND** all instructions carefully before starting the installation. **FAILURE TO FOLLOW** these installation instructions may result in a possible fire hazard and will void the warranty.

 Prior to the first firing of the fireplace, **READ** the Using Your Fireplace section of the *Owners Guide*.

 **DO NOT USE** this appliance if any part has been under water. Immediately **CALL** a qualified service technician to inspect the unit and to replace any part of the control system and any gas control which has been under water.

 **THIS UNIT IS NOT FOR USE WITH SOLID FUEL.**

 Installation and repair should be **PERFORMED** by a qualified service person. The appliance and venting system should be **INSPECTED** before initial use and at least annually by a professional service person. More frequent cleaning may be required due to excessive lint from carpeting, bedding material, etc. It is **IMPERATIVE** that the unit's control compartment, burners, and circulating air passageways **BE KEPT CLEAN** to provide for adequate combustion and ventilation air.

 Always **KEEP** the appliance clear and free from combustible materials, gasoline, and other flammable vapors and liquids.

 **NEVER OBSTRUCT** the flow of combustion and ventilation air. Keep the front of the appliance **CLEAR** of all obstacles and materials for servicing and proper operations.

 Due to the high temperature, the appliance should be **LOCATED** out of traffic areas and away from furniture and draperies. Clothing or flammable material **SHOULD NOT BE PLACED** on or near the appliance.

 Children and adults should be **ALERTED** to the hazards of high surface temperature and should **STAY AWAY** to avoid burns or clothing ignition. Young children should be **CAREFULLY SUPERVISED** when they are in the same room as the appliance.

 These units **MUST** use one of the vent systems described in the Installing the Fireplace section of the *Installers Guide*. **NO OTHER** vent systems or components **MAY BE USED**.

 This gas fireplace and vent assembly **MUST** be vented directly to the outside and **MUST NEVER** be attached to a chimney serving a separate solid fuel burning appliance. Each gas appliance **MUST USE** a separate vent system. Common vent systems are **PROHIBITED**.

 **INSPECT** the external vent cap on a regular basis to make sure that no debris is interfering with the air flow.

 The glass door assembly **MUST** be in place and sealed, and the trim door assembly **MUST** be in place on the fireplace before the unit can be placed into safe operation.

 **DO NOT OPERATE** this appliance with the glass door removed, cracked, or broken. Replacement of the glass door should be performed by a licensed or qualified service person. **DO NOT** strike or slam the glass door.

 The glass door assembly **SHALL ONLY** be replaced as a complete unit, as supplied by the gas fireplace manufacturer. **NO SUBSTITUTE** material may be used.

 **DO NOT USE** abrasive cleaners on the glass door assembly. **DO NOT ATTEMPT** to clean the glass door when it is hot.

 Turn off the gas before servicing this appliance. It is recommended that a qualified service technician perform an appliance check-up at the beginning of each heating season.

 Any safety screen or guard removed for servicing must be replaced before operating this appliance.

 **DO NOT** place furniture or any other combustible household objects within 36 inches of the fireplace front.

# TABLE OF CONTENTS

<b>Safety and Warning Information</b> .....	2
<b>→ Service Parts Lists</b> .....	4
<b>Section 1: Approvals and Codes</b> .....	7
Appliance Certification .....	7
Installation Codes .....	7
High Altitude Installations .....	7
<b>Section 2: Getting Started</b> .....	8
Introducing the Quadra-Fire Gas Fireplaces .....	8
Pre-installation Preparation .....	8
<b>Section 3: Installing the Fireplace</b> .....	10
Constructing the Fireplace Chase .....	10
Step 1 Locating the Fireplace .....	10
Step 2 Framing the Fireplace .....	11
Step 3 Installing the Vent System .....	13
A. Vent System Approvals .....	13
B. Installing Vent Components .....	20
C. Vent Termination .....	23
Step 4 Positioning, Leveling, and Securing the Fireplace .....	26
Step 5 The Gas Control System .....	26
Step 6 The Gas Supply Line .....	27
Step 7 Gas Pressure Requirements .....	27
Step 8 Wiring the Fireplace .....	28
Step 9 Finishing .....	29
Step 10 Installing Trim, Logs, and Ember Material .....	30
Installing the Trim .....	30
Refractory Kit Placement .....	30
Positioning the Logs .....	31
Shutter Settings .....	31
Placing the Ember Material .....	31
Glass Specifications .....	31
Step 11 Before Lighting the Fireplace .....	31
Step 12 Lighting the Appliance .....	32
Step 13 Climate Control .....	33
After the Installation .....	33
<b>Section 4: Maintaining and Servicing Your Fireplace</b> .....	33
<b>Section 5: Troubleshooting</b> .....	34
<b>Limited Lifetime Warranty</b> .....	36
<b>→ Contact Information</b> .....	37

→ = Contains updated information.

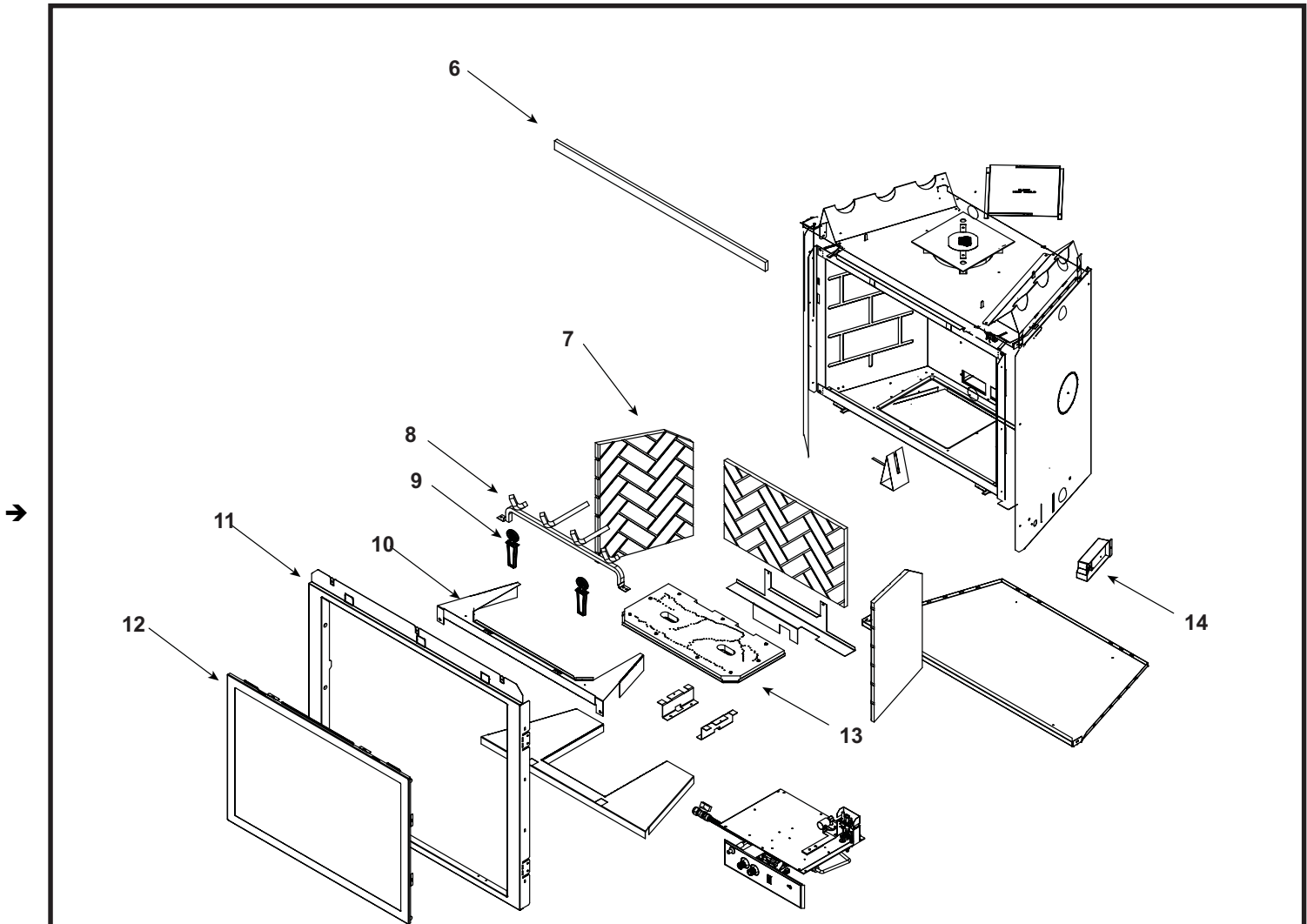

**Log Set Assembly**



Part number list on following page.

# Service Parts List

QV36DB-A

➔ **IMPORTANT: THIS IS DATED INFORMATION.** When Requesting service or replacement parts for your appliance please provide model number and serial number. All parts listed in this manual may be ordered from an authorized dealer.



**Stocked  
at Depot**

ITEM	DESCRIPTION	SERIAL #	PART NUMBER	Stocked at Depot
	Log Set Assembly		LOGS-2018	Y
1	Log 1		SRV2018-701	N
2	Log 2		SRV385-736	N
3	Log 3		SRV278-704	N
4	Log 4		SRV2018-704	N
5	Log 5		SRV780-707	N
6	Non Combustible board		385-401	N
7	Refractory Kit (Sold as set only)		BRICK-292	N
8	Log Grate		2018-001	N
9	Andirons, Cast		80784	N
10	Base Refractory NG, LP		2018-100	N
11	Surround		2026-108	N
12	Glass Door Assembly		GLA-6TRX1	Y
13	Burner		2018-005	Y
14	Junction Box		4021-013	Y
	Mesh		Mesh -6000	Y
	Glass Latch Assembly		386-122A	Y
	Exhaust Restrictor		2027-102	N
	Pilot Tube		SRV485-301	Y
	Thermocouple		446-511	Y
	Thermopile		060-512	Y
	Lava Rock Bag		060-721	N
	Mineral Wool		050-721	N
	Gasket Assembly Includes: Vent, Seal Cap, Burner Neck, Shutter Bracket, and Valve Plate Gaskets		385-402A	N
	Touch Up Paint		TUP-GBK-12	N
	Conversion Kit NG		NGK-2018	Y
	Conversion Kit LP		LPK-2018	Y
	Regulator NG		060-518	Y
	Regulator LP		060-519	Y
	Pilot Orifice NG		446-505	Y
	Pilot Orifice LP		446-517	Y

Additional service part numbers appear on following page.

**Standing Pilot Ignition  
Valve Assembly**

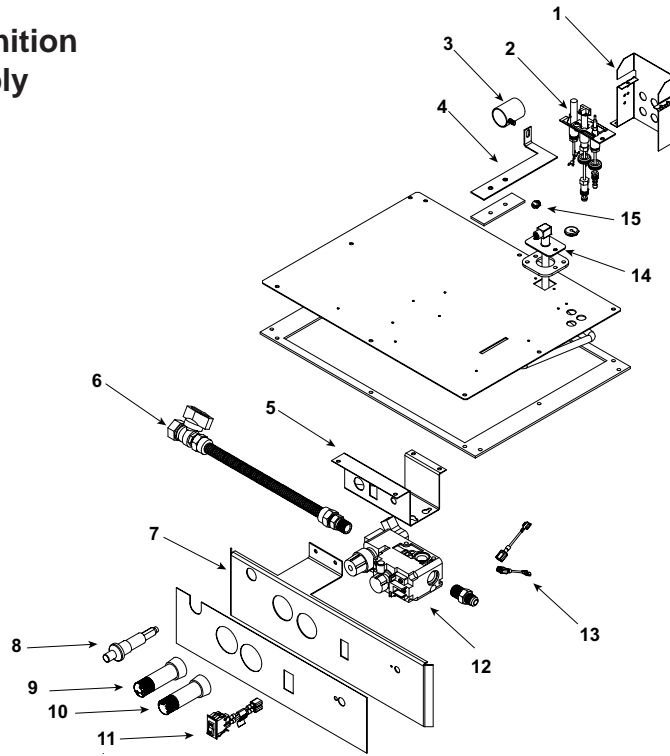

➔ **IMPORTANT: THIS IS DATED INFORMATION.** When Requesting service or replacement parts for your appliance please provide model number and serial number. All parts listed in this manual may be ordered from an authorized dealer.



**Stocked  
at Depot**

ITEM	DESCRIPTION	SERIAL #	PART NUMBER	
1	Pilot Bracket		2018-107	N
2	Pilot Assembly NG		530-510A	Y
	Pilot Assembly LP		530-511A	Y
3	Shutter Assembly		319-316A	Y
4	Shutter Bracket Assembly		2026-017	Y
5	Valve Bracket		550-169	N
6	Flex Ball Valve Assembly		302-320A	Y
7	Control Panel		295-119	N
8	Piezo Ignitor		291-513	Y
9	Pilot Control Knob		571-530	Y
10	Flame Control Knob		571-531	Y
11	ON/OFF Rocker Switch		060-521A	Y
12	Valve NG		060-522	Y
	Valve LP		060-523	Y
13	Wire Assembly		049-552A	Y
14	Flexible Gas Connector		383-302A	Y
15	Orifice NG (3.1 MM)		582-8310	Y
	Orifice LP ( 1.8 MM)		582-818	Y

# 1

## Approvals and Codes

---

### Appliance Certification

The fireplace model discussed in this *Installers Guide* has been tested to certification standards and listed by the applicable laboratories.

Certification
<b>MODEL:</b> QV36DB-A
<b>LABORATORY:</b> Underwriters Laboratories
<b>TYPE:</b> Direct Vent Gas Fireplace Heater
<b>STANDARD:</b> ANSIZ21.88-2000•CSA2.33-M98•UL307B

### Installation Codes

The fireplace installation must conform to local codes. Before installing the fireplace, consult the local building code agency to ensure that you are in compliance with all applicable codes, including permits and inspections.

In the absence of local codes, the fireplace installation must conform to the National Fuel Gas Code ANSI Z223.1 (in the United States) or the CAN/CGA-B149 Installation Codes (in Canada). The appliance must be electrically grounded in accordance with local codes or, in the absence of local codes with the National Electric Code ANSI/NFPA No. 70 (in the United States), or to the CSA C22.1 Canadian Electric Code (in Canada).

This model may be installed in a bedroom or bed-sitting room in the U.S.A. and Canada.

### High Altitude Installations

U.L. Listed gas appliances are tested and approved without requiring changes for elevations from 0 to 2,000 feet in the U. S. A. and in Canada.

When installing this appliance at an elevation above 2,000 feet, it may be necessary to decrease the input rating by changing the existing burner orifice to a smaller size. Input rate should be reduced by 4% for each 1000 feet above a 2000 foot elevation in the U.S.A. or 10% for elevations between 2000 and 4500 feet in Canada. If the heating value of the gas has been reduced, these rules do not apply. To identify the proper orifice size, check with the local gas utility.

If installing this appliance at an elevation above 4,500 feet (in Canada), check with local authorities.



# 2

## Getting Started

---

### Introducing the Village Collection Gas Fireplaces

Quadra-Fire direct vent gas fireplaces are designed to operate with all combustion air siphoned from outside of the building and all exhaust gases expelled to the outside.

The information contained in this *Installers Guide*, unless noted otherwise, applies to all models and gas control systems. Gas fireplace diagrams, including the dimensions, are shown in this section.

#### Pre-installation Preparation

This gas fireplace and its components are tested and safe when installed in accordance with this *Installers Guide*. Report to your dealer any parts damaged in shipment, particularly the condition of the glass. **Do not install any unit with damaged, incomplete, or substitute parts.**

The vent system components and trim doors are shipped in separate packages. The gas logs may be packaged separately and must be field installed.

**Read all of the instructions before starting the installation. Follow these instructions carefully during the installation to ensure maximum safety and benefit. Failure to follow these instructions will void the owner's warranty and may present a fire hazard.**

The Hearth & Home Technologies Warranty will be voided by, and Hearth & Home Technologies disclaims any responsibility for, the following actions:

- Installation of any damaged fireplace or vent system component.
- Modification of the fireplace or direct vent system.
- Installation other than as instructed by Hearth & Home Technologies.
- Improper positioning of the gas logs or the glass door.
- Installation and/or use of any component part not manufactured and approved by Hearth & Home Technologies, notwithstanding any independent testing laboratory or other party approval of such component part or accessory.

**ANY SUCH ACTION MAY POSSIBLY CAUSE A FIRE HAZARD.**

When planning a fireplace installation, it's necessary to determine:

- Where the unit is to be installed.
- The vent system configuration to be used.
- Gas supply piping.
- Electrical wiring.
- Framing and finishing details.
- Whether optional accessories—devices such as a fan, wall switch, or remote control—are desired.

If the fireplace is to be installed on carpeting or tile, or on any combustible material other than wood flooring, the fireplace should be installed on a metal or wood panel that extends the full width and depth of the fireplace.



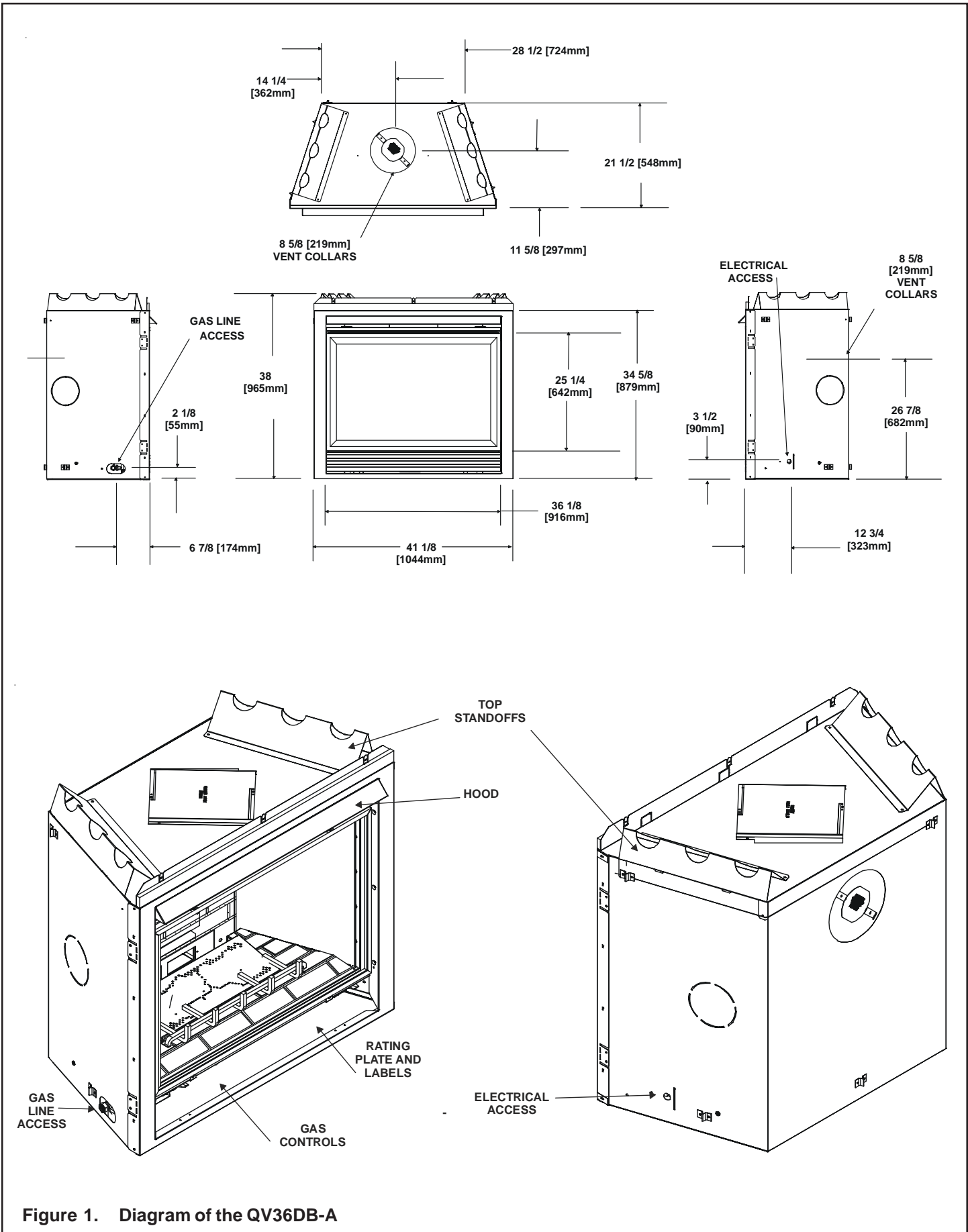

Figure 1. Diagram of the QV36DB-A

# 3

## Installing the Fireplace

### Constructing the Fireplace Chase

A chase is a vertical box-like structure built to enclose the gas fireplace and/or its vent system. Vertical vents that run on the outside of a building may be, but are not required to be, installed inside a chase.

**CAUTION:** TREATMENT OF FIRESTOP SPACERS AND CONSTRUCTION OF THE CHASE MAY VARY WITH THE TYPE OF BUILDING. THESE INSTRUCTIONS ARE NOT SUBSTITUTES FOR THE REQUIREMENTS OF LOCAL BUILDING CODES. THEREFORE, YOUR LOCAL BUILDING CODES **MUST** BE CHECKED TO DETERMINE THE REQUIREMENTS FOR THESE STEPS.

Factory-built fireplace chases should be constructed in the manner of all outside walls of the home to prevent cold air drafting problems. The chase should not break the outside building envelope in any manner.

This means that the walls, ceiling, base plate and cantilever floor of the chase should be insulated. Vapor and air infiltration barriers should be installed in the chase as per regional codes for the rest of the home. Additionally, we recommend that the inside surfaces be sheetrocked and taped for maximum air tightness.

To further prevent drafts, the firestops should be caulked to seal gaps. Gas line holes and other openings should be caulked or stuffed with insulation. If the unit is being installed on a cement slab, we recommend that a layer of plywood be placed underneath to prevent conducting cold up into the room.

**THE CHASE SHOULD BE CONSTRUCTED SO THAT ALL CLEARANCES TO THE FIREPLACE ARE MAINTAINED AS SPECIFIED WITHIN THIS INSTALLERS GUIDE.**

### Step 1. Locating the Fireplace

The following diagram shows space and clearance requirements for locating a fireplace within a room.

#### Clearance Requirements

The top, back, and sides of the fireplace are defined by stand-offs. The minimum clearance to a perpendicular wall extending past the face of the fireplace is one inch (25 mm). The back of the fireplace may be recessed 21 1/2 inches (546 mm) into combustible construction.

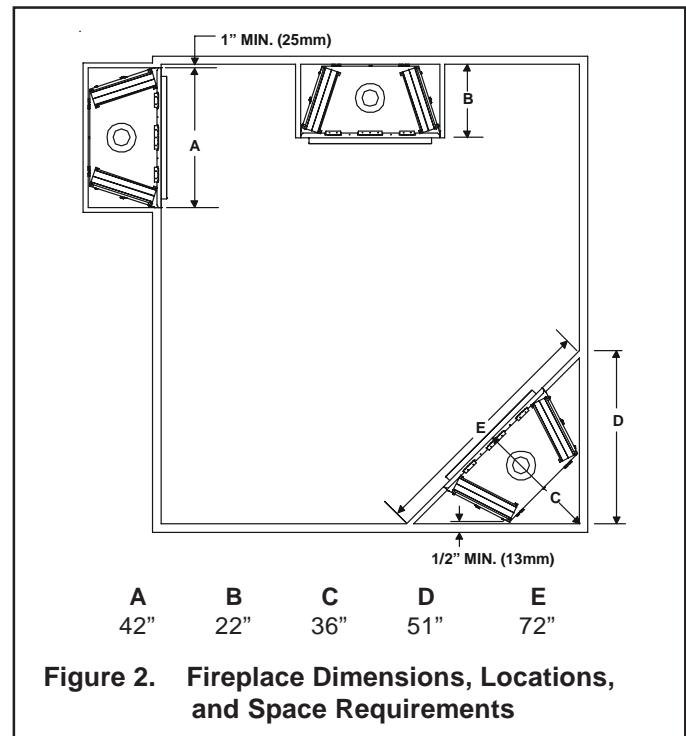

**Figure 2. Fireplace Dimensions, Locations, and Space Requirements**

#### Minimum Clearances from the Fireplace to Combustible Materials

	<u>Inches</u>	<u>mm</u>
Glass Front .....	36	914
Floor .....	0	0
Rear .....	1/2	13
Sides .....	1/2	13
Surround Sides* .....	0	0
Top .....	3 1/2	89
Ceiling** .....	31	787

\* See Figure 3.

\*\* The clearance to the ceiling is measured from the top of the unit, excluding the standoffs (see Figure 36).

The distance from the unit to combustible construction is to be measured from the unit outer wrap surface to the combustible construction, **NOT** from the screw heads that secure the unit together.

#### Minimum Clearances from the Vent Pipe to Combustible Materials

	<u>Inches</u>	<u>mm</u>
<b>Vertical Sections</b> .....	1	25
<b>Horizontal Sections</b>		
Top .....	3	75
Bottom .....	1	25
Sides .....	1	25
<b>At Wall Firestops</b>		
Top .....	2 1/2	63.7
Bottom .....	1/2	13
Sides .....	1	25

For minimum clearances, see the direct vent termination clearance diagrams (see Figures 30 and 31).

## Step 2. Framing the Fireplace

Fireplace framing can be built before or after the fireplace is set in place. Framing should be positioned to accommodate wall coverings and fireplace facing material. The diagram below shows framing reference dimensions.

**CAUTION: MEASURE FIREPLACE DIMENSIONS AND VERIFY FRAMING METHODS AND WALL COVERING DETAILS BEFORE FRAMING.**

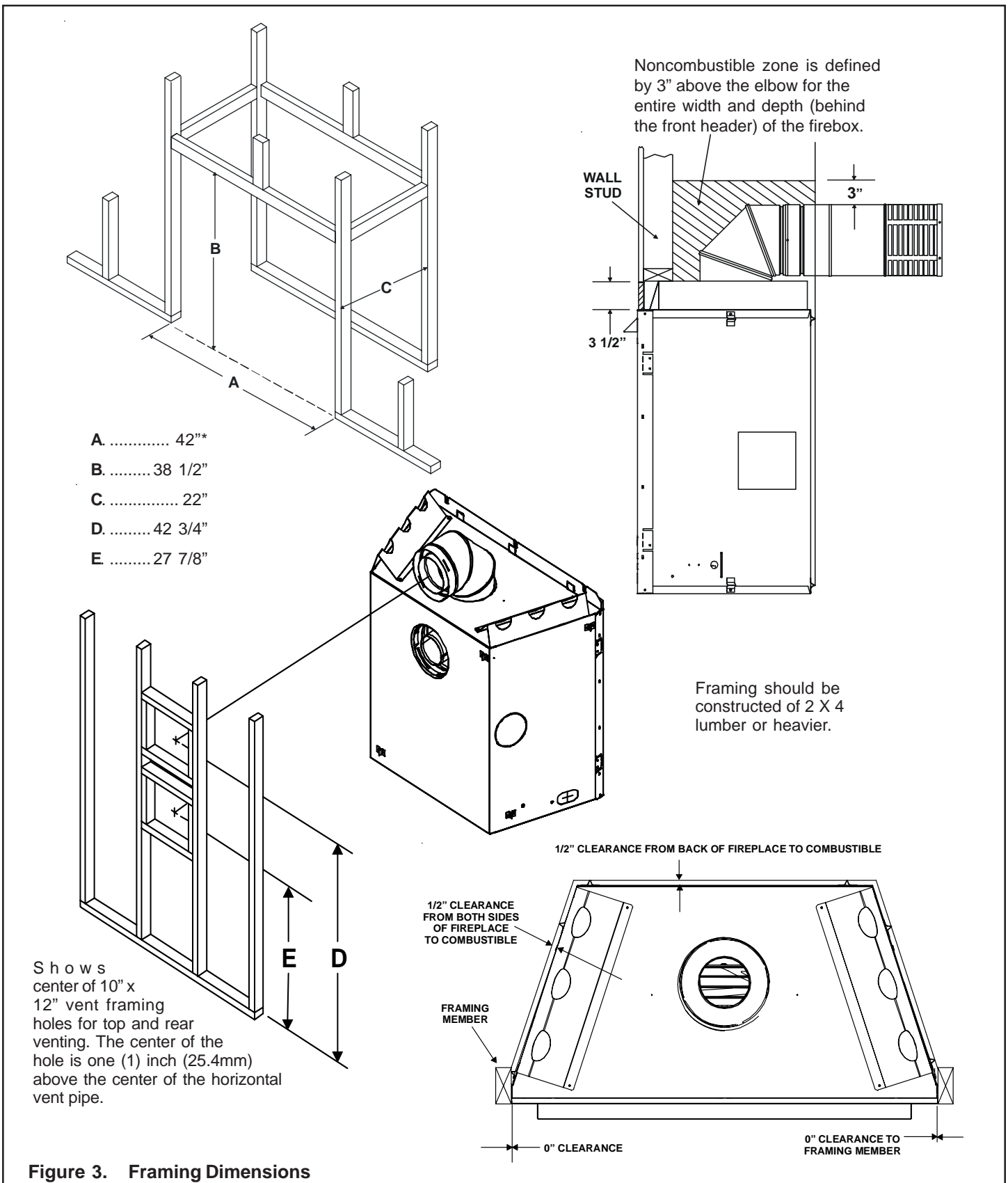

**Figure 3. Framing Dimensions**

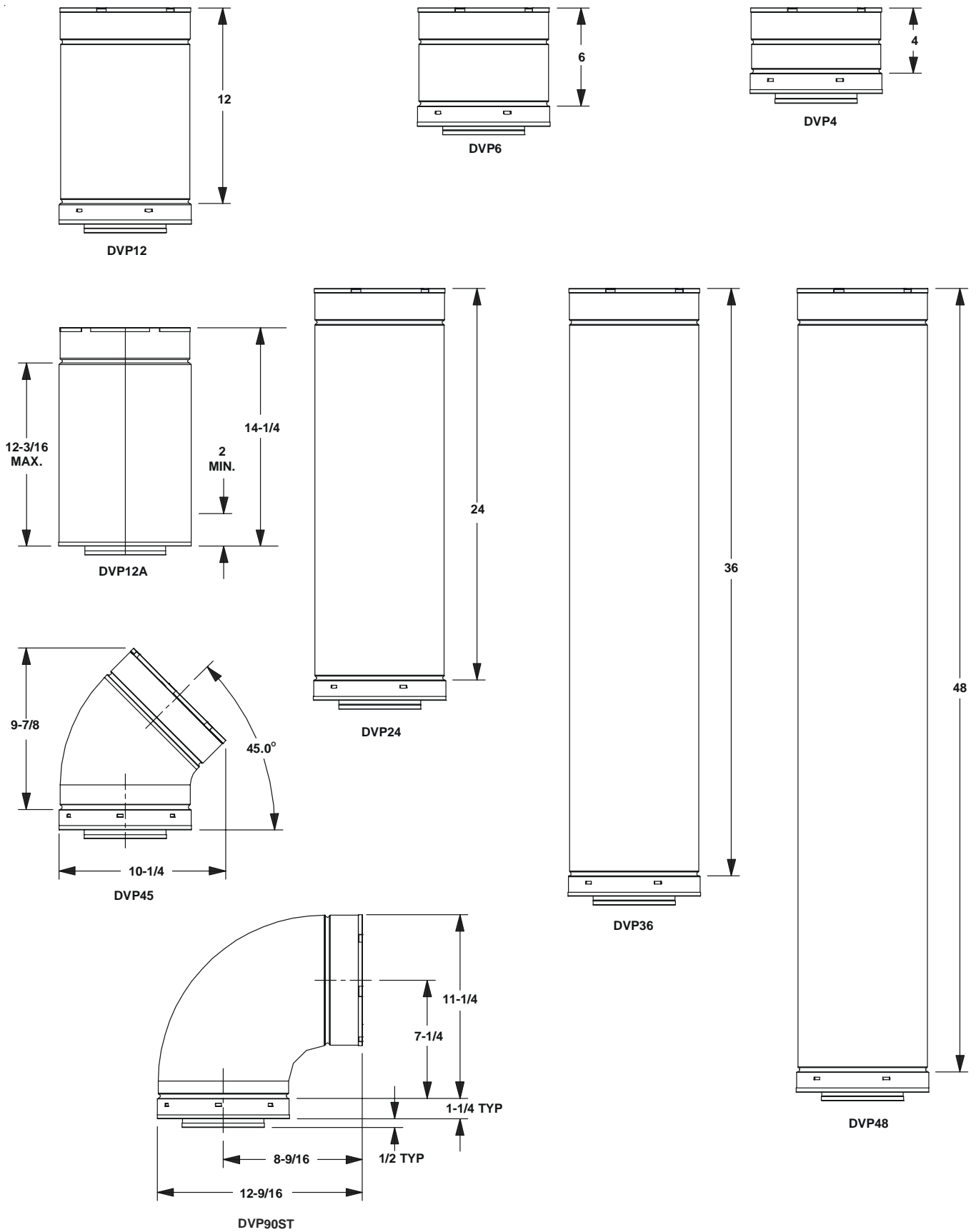

NOTE: PIPES OVERLAP 1-1/4 INCHES AT EACH JOINT.

Figure 4. DVP-Series Direct Vent Component Specifications (5-inch inner pipe / 8-inch outer pipe)

### Step 3. Installing the Vent System

#### A. Vent System Approvals

This model is approved to use DVP-series direct vent pipe components and terminations (see Figures 4 and 5). Approved vent system components are labeled for identification. This pipe is tested and listed as an approved component of the fireplace. The pipe is tested to be run inside an enclosed wall. There is no requirement for inspection openings at each joint within the wall. There is no required pitch for horizontal vent runs. **NO OTHER VENTING SYSTEMS OR COMPONENTS MAY BE USED.**

Detailed installation instructions are included with each vent termination kit and should be used in conjunction with this *Installers Guide*. The flame and ember appearance may vary based on the type of fuel burned and the venting configuration used.

#### Identifying Vent Components

The vent systems installed on this gas fireplace may include one, two, or three 90° elbow assemblies. The relationships of vertical rise to horizontal run in vent configurations using 90° elbows **MUST BE** strictly adhered to. The rise to run relationships are shown in the venting drawings and tables. Refer to the diagrams on the next several pages.

**NOTE: Two 45° elbows may be used in place of one 90° elbow. Rise to run ratios in the vent system must be followed if 45° elbows are used.**

This model has vent starting collars on both the top and the back of the unit. Depending upon the installation, decide which **ONE** set of starting collars will be used to attach the vent system. The starting collar sealing cap must remain on the starting collar **NOT** used.

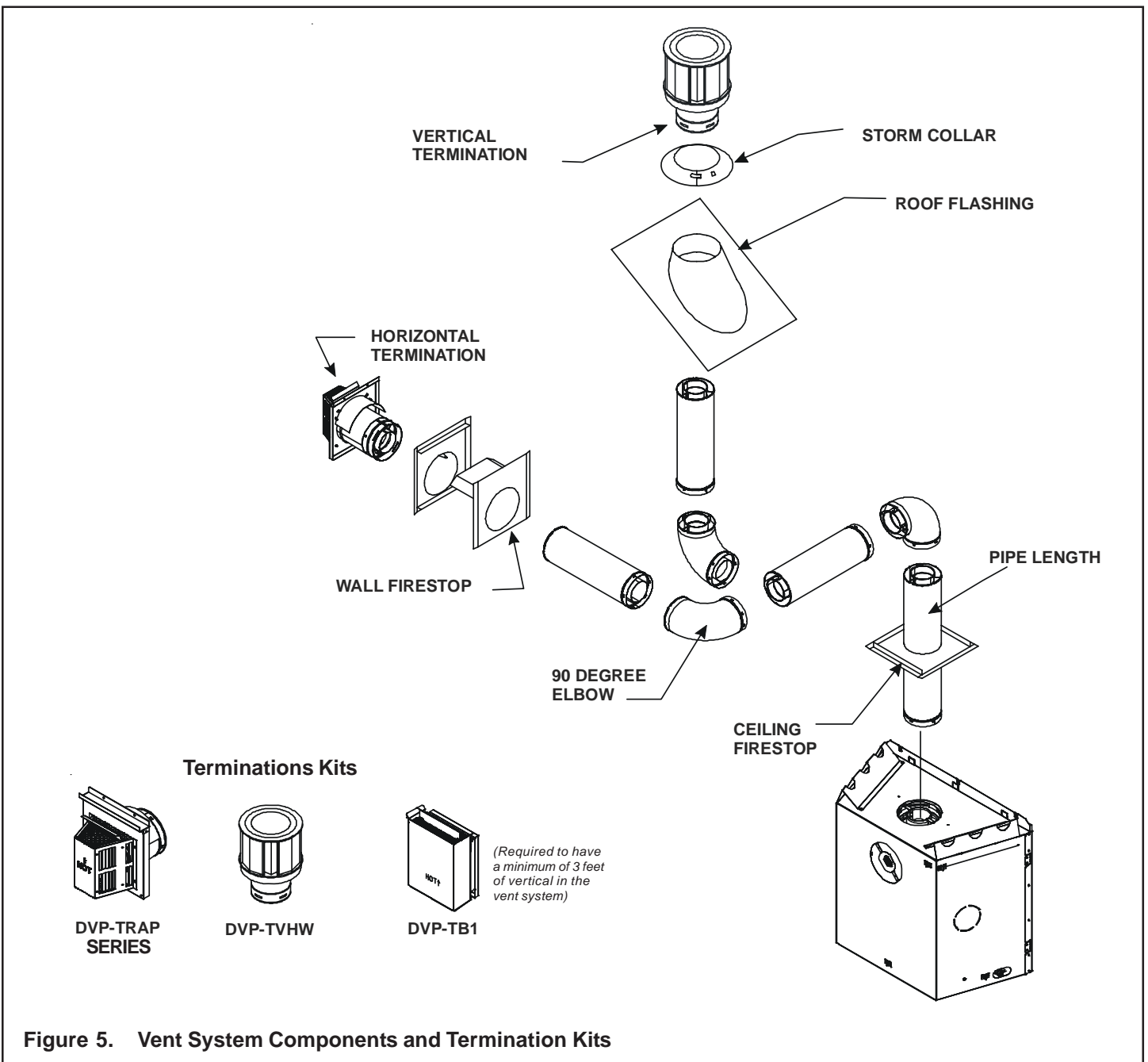
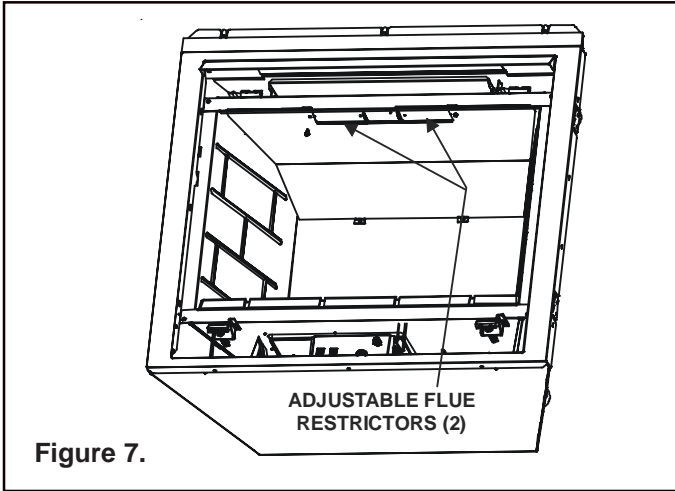
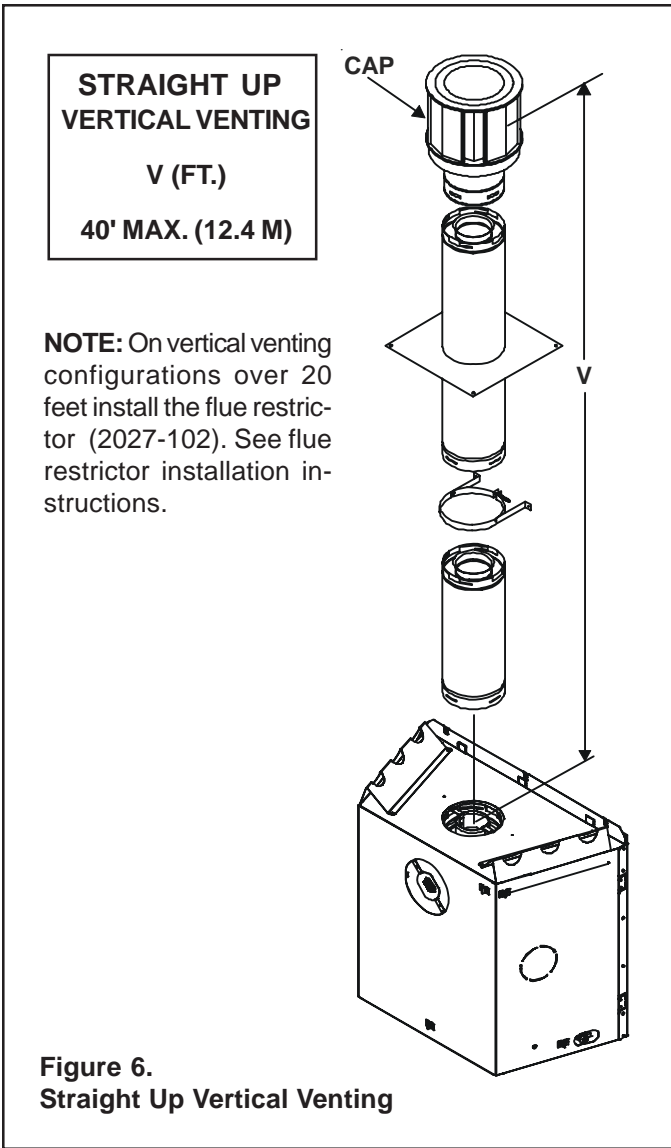

Figure 5. Vent System Components and Termination Kits



**- CHART -**

Vertical	Top Vent NG	Top Vent LP	Rear Vent NG	Rear Vent LP
4'	2-2	2-3	No Restrictor	No Restrictor
8'	3-3	2-3	2-2	No Restrictor
15'	3-4	3-4	3-3	2-3
20'	4-4	3-4	3-4	3-4
25'	4-4	3-4	3-4	3-4
30'	4-4	4-4	4-4	3-4
35'	4-4	4-4	4-4	3-4
40'	4-5	4-4	4-4	4-4

**Flue Restrictor Instructions**

1. Remove screws with a 1/4 nut driver. Adjust to desired position per table. See Flue Restricting chart.

Adjustable Flue Restrictor (see Figure 8).

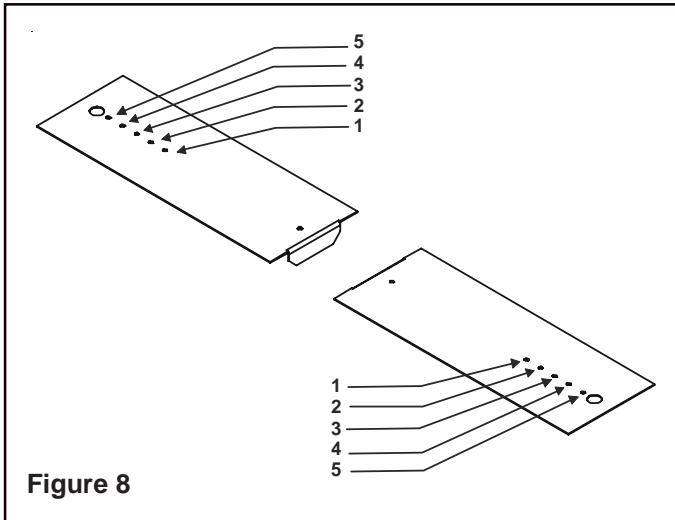

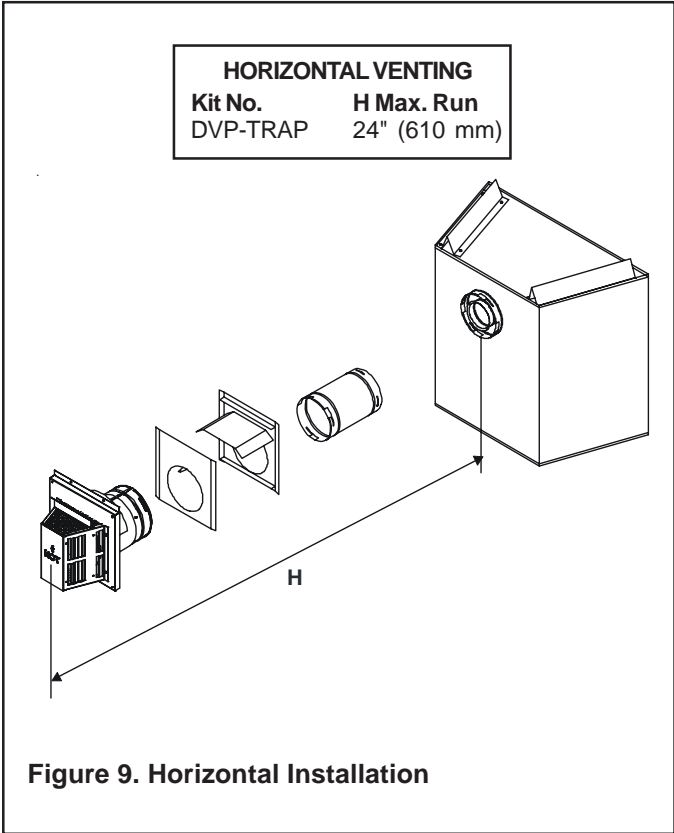
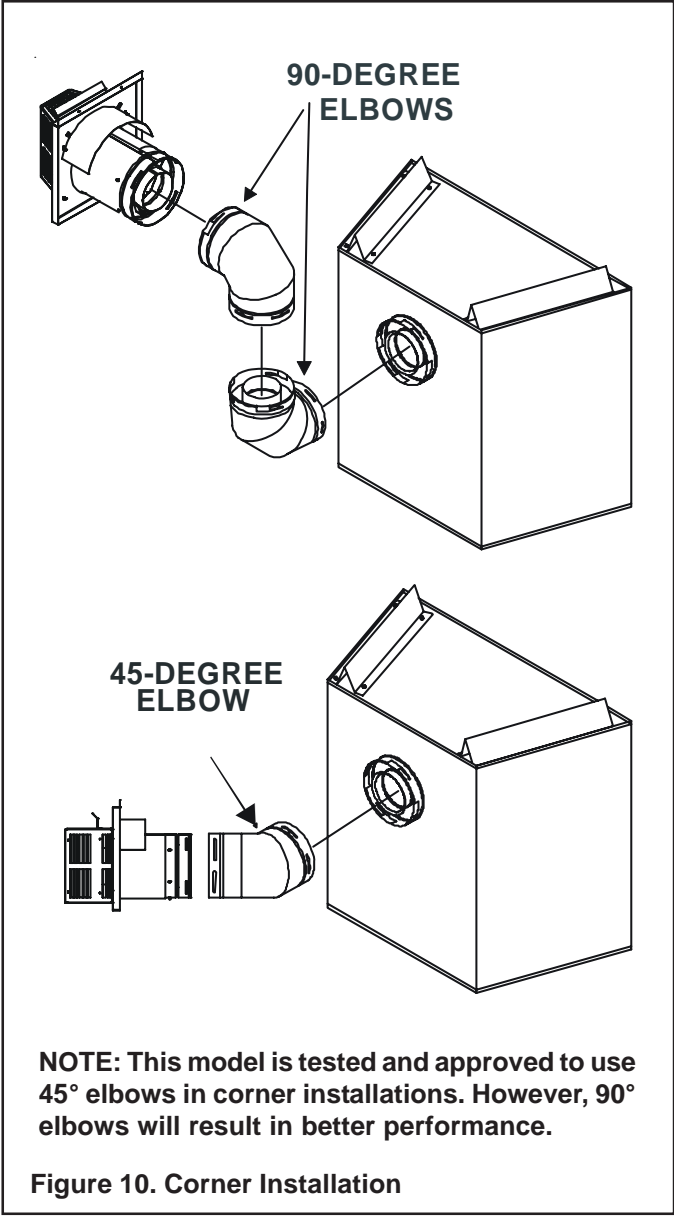

Figure 9. Horizontal Installation



**NOTE:** This model is tested and approved to use 45° elbows in corner installations. However, 90° elbows will result in better performance.

Figure 10. Corner Installation



### VENTING WITH ONE (1) 90° ELBOW

V	H
1' MIN. (305mm)	2' MAX. (610mm)
2' MIN. (610mm)	4' MAX. (1.22m)
3' MIN. (914mm)	6' MAX. (1.86m)
4' MIN. (1.22m)	8' MAX. (2.4m)

V+H=40' MAX. (12.4m)    H = 8' MAX. (2.4m)

**NOTE:** On vertical venting configurations where the vertical component is over 10 feet install the vertical baffle included in the manual bag assembly to improve flame appearance.

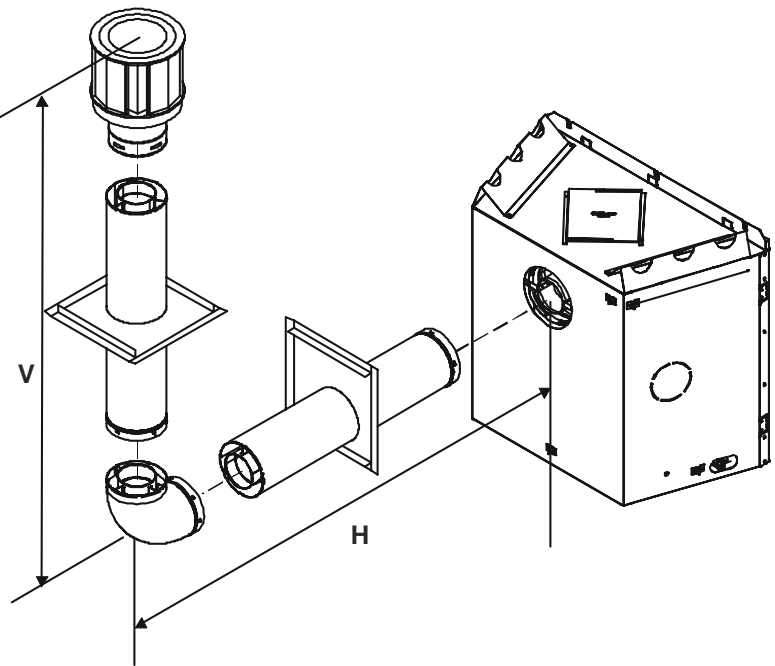
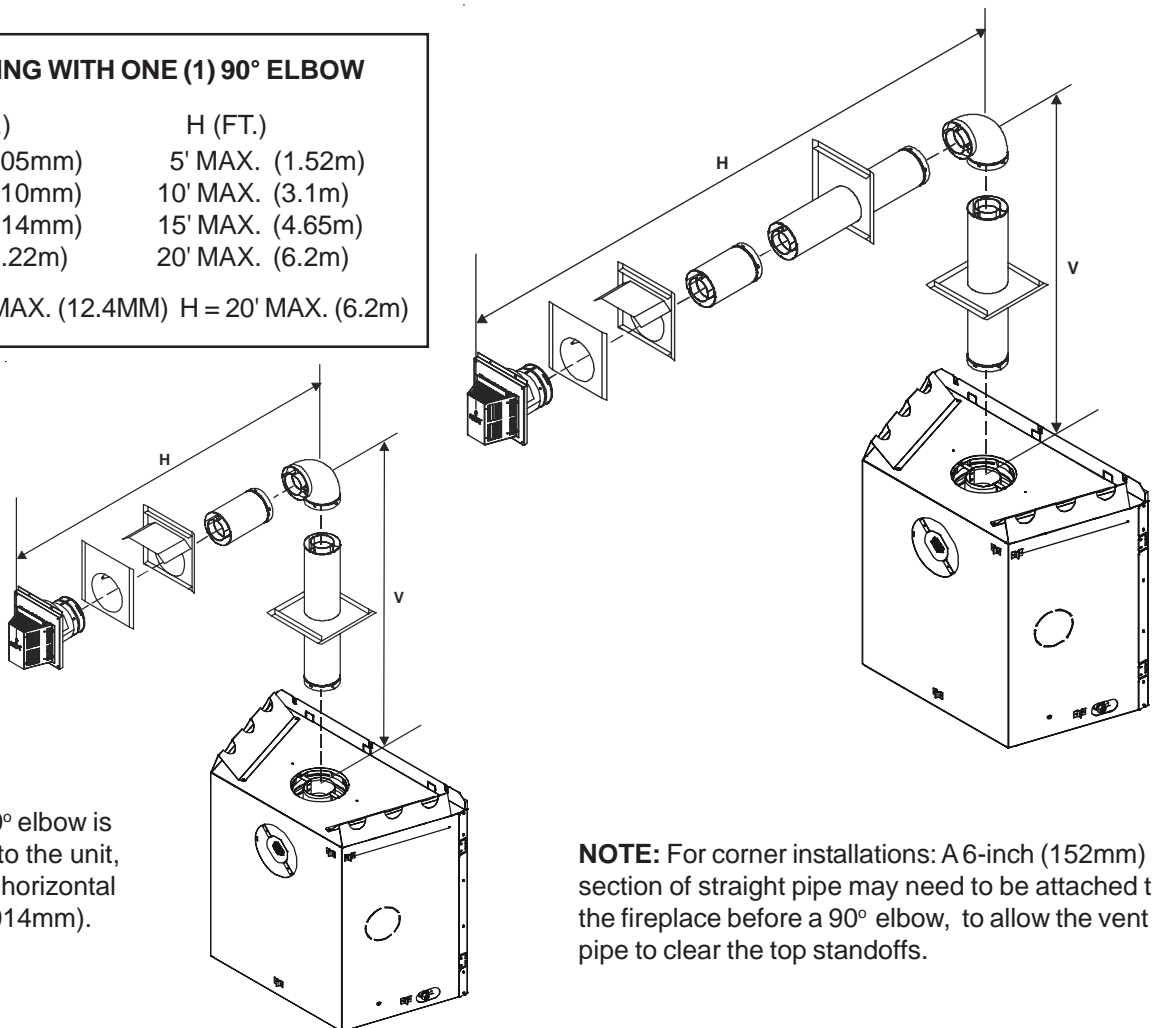

Figure 11. Venting with One 90° Elbow

### VENTING WITH ONE (1) 90° ELBOW

V (FT.)	H (FT.)
1' MIN. (305mm)	5' MAX. (1.52m)
2' MIN. (610mm)	10' MAX. (3.1m)
3' MIN. (914mm)	15' MAX. (4.65m)
4' MIN. (1.22m)	20' MAX. (6.2m)

V+H=40' MAX. (12.4MM)    H = 20' MAX. (6.2m)



**NOTE:** If a 90° elbow is first attached to the unit, the maximum horizontal run is 3-feet (914mm).

**NOTE:** For corner installations: A 6-inch (152mm) section of straight pipe may need to be attached to the fireplace before a 90° elbow, to allow the vent pipe to clear the top standoffs.

Figure 12. Venting with One 90° Elbow

### VENTING WITH TWO (2) 90° ELBOWS

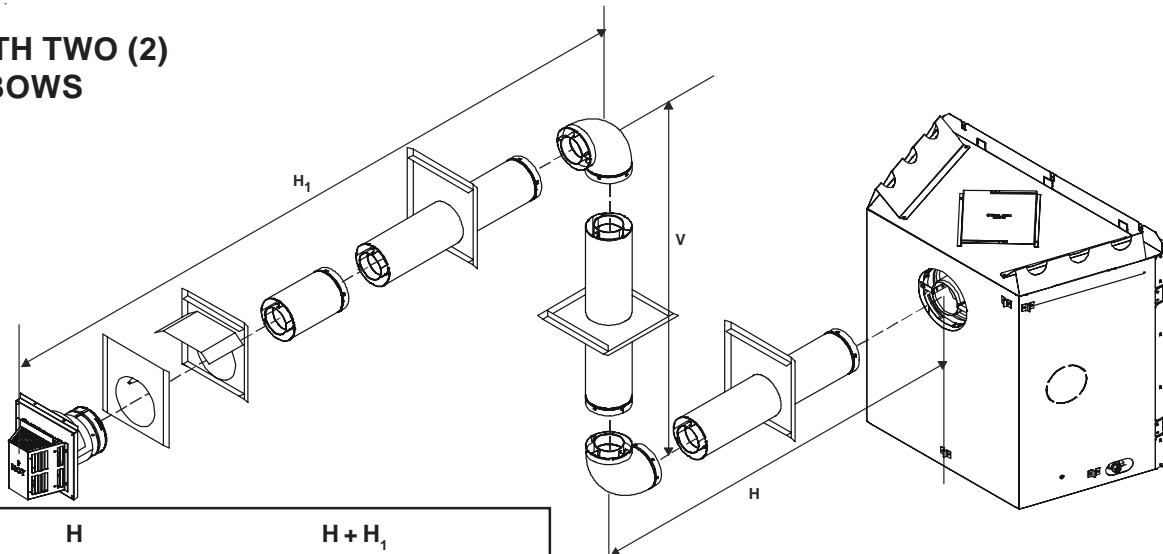

V	H	H + H <sub>1</sub>
1' MIN. (305 mm)	2' MAX. (610 mm)	5' MAX. (1.52m)
2' MIN. (610 mm)	4' MAX. (1.22 m)	10' MAX. (3.1m)
3' MIN. (914 mm)	6' MAX. (1.86 m)	15' MAX. (4.65m)
4' MIN. (1.22 m)	8' MAX. (2.48 m)	20' MAX. (6.2m)
V+H+H <sub>1</sub> = 40' MAX. (12.4 m)		H = 8' MAX. (2.48 m)
		H+H <sub>1</sub> = 20' MAX. (6.2m)

Figure 13. Venting with Two 90° Elbows

### VENTING WITH TWO (2) 90° ELBOWS

V FT.	H + H <sub>1</sub> (FT.)
1' MIN. (305mm)	5' MAX. (1.52m)
2' MIN. (610mm)	10' MAX. (3.1m)
3' MIN. (914mm)	15' MAX. (4.65m)
4' MIN. (1.22m)	20' MAX. (6.2m)
V+H+H <sub>1</sub> = 40' MAX. (12.4m)	
V+V <sub>1</sub> +H = 40' MAX. (12.4m)	
H+H <sub>1</sub> = 20' MAX. (6.2m)	

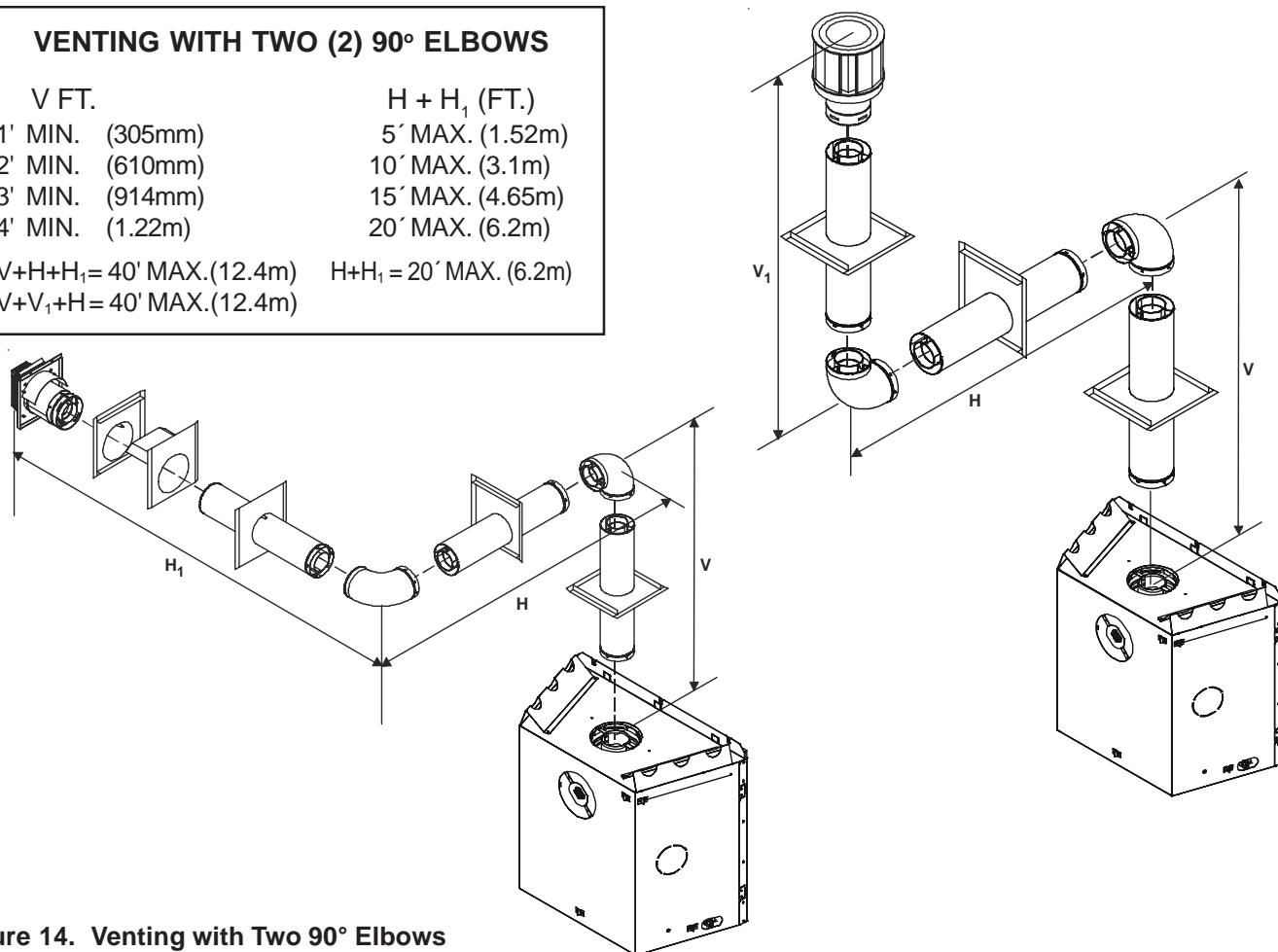
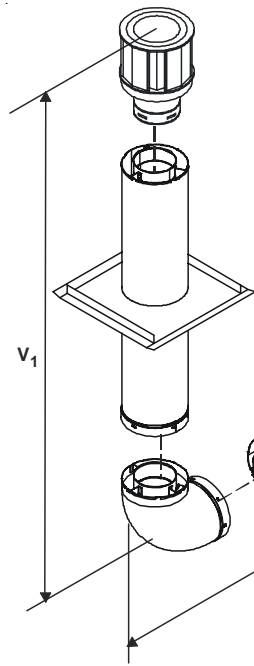

Figure 14. Venting with Two 90° Elbows

### VENTING WITH THREE (3) 90° ELBOWS



V	H	H + H <sub>1</sub>
1' MIN. (305mm)	2' MAX. (610mm)	5' MAX. (1.52m)
2' MIN. (610mm)	4' MAX. (1.22m)	10' MAX. (3.1m)
3' MIN. (914mm)	6' MAX. (1.86m)	15' MAX. (4.65m)
4' MIN. (1.22m)	8' MAX. (2.48m)	20' MAX. (6.2m)

V<sub>1</sub>+V+H+H<sub>1</sub> = 40' MAX.(12.4 m)    H = 8' MAX.(2.48 m)    H+H<sub>1</sub> = 20' MAX.(6.2 m)

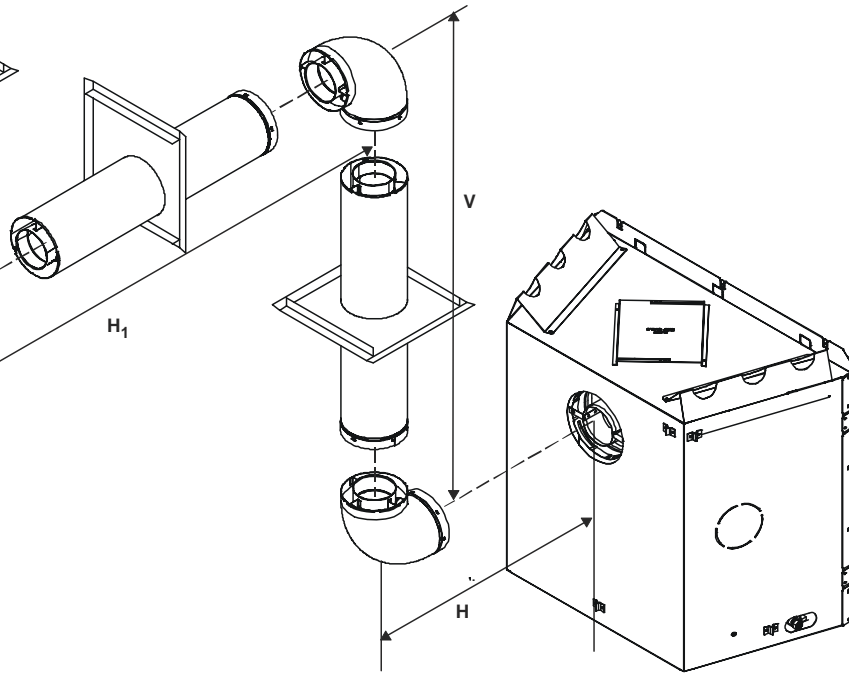

V	H	H + H <sub>1</sub> + H <sub>2</sub>
1' MIN. (305mm)	2' MAX. (610mm)	5' MAX. (1.52m)
2' MIN. (610mm)	4' MAX. (1.22m)	10' MAX. (3.1m)
3' MIN. (914mm)	6' MAX. (1.86m)	15' MAX. (4.65m)
4' MIN. (1.22m)	8' MAX. (2.48m)	20' MAX. (6.2m)

V+H+H<sub>1</sub>+H<sub>2</sub> = 40' MAX. (12.4 m)    H = 8' MAX. (2.48 m)    H+H<sub>1</sub>+H<sub>2</sub> = 20' MAX. (6.2 m)

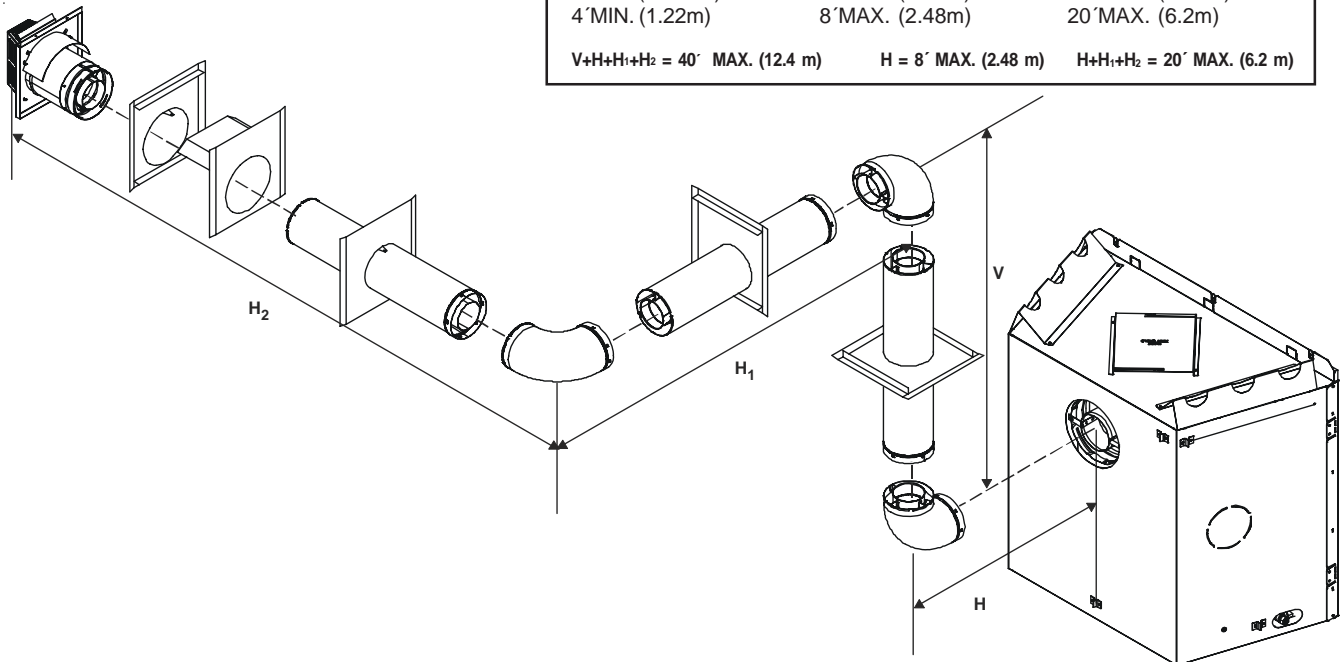
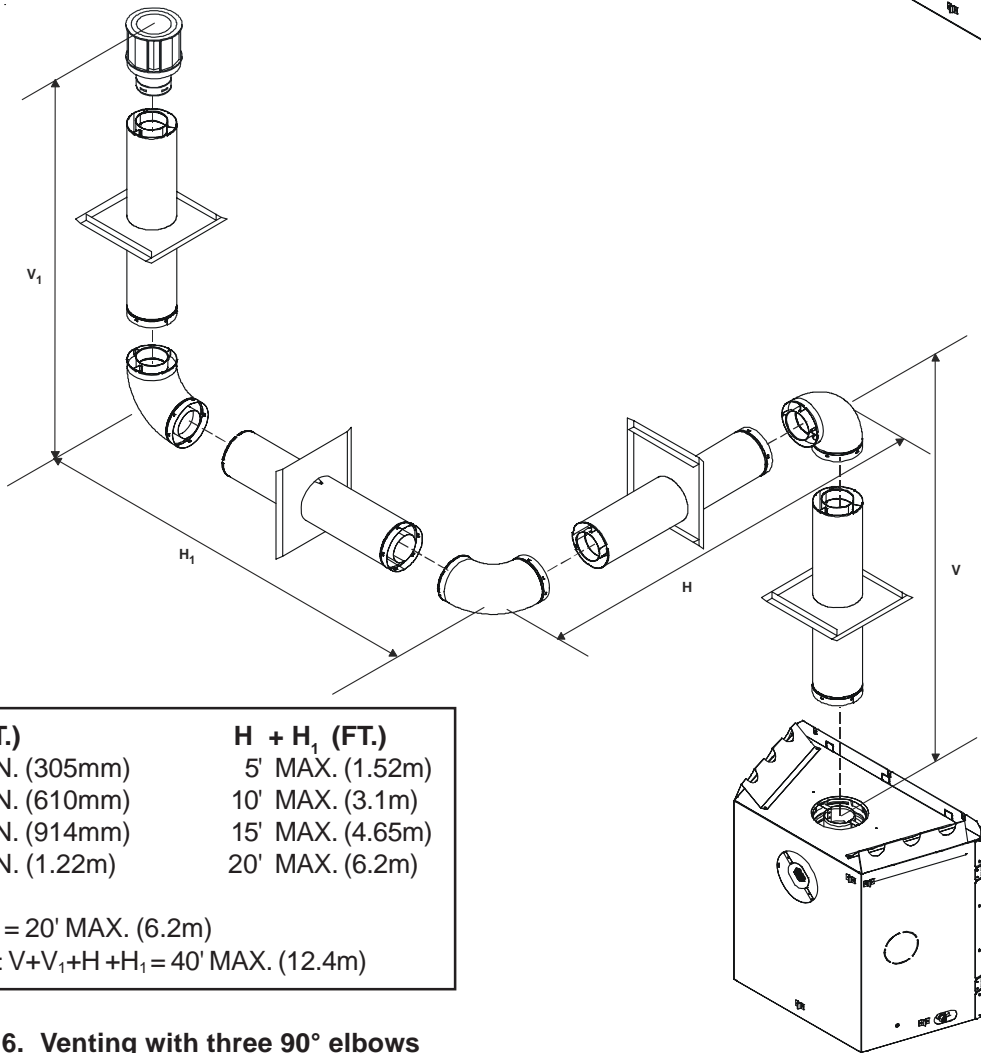
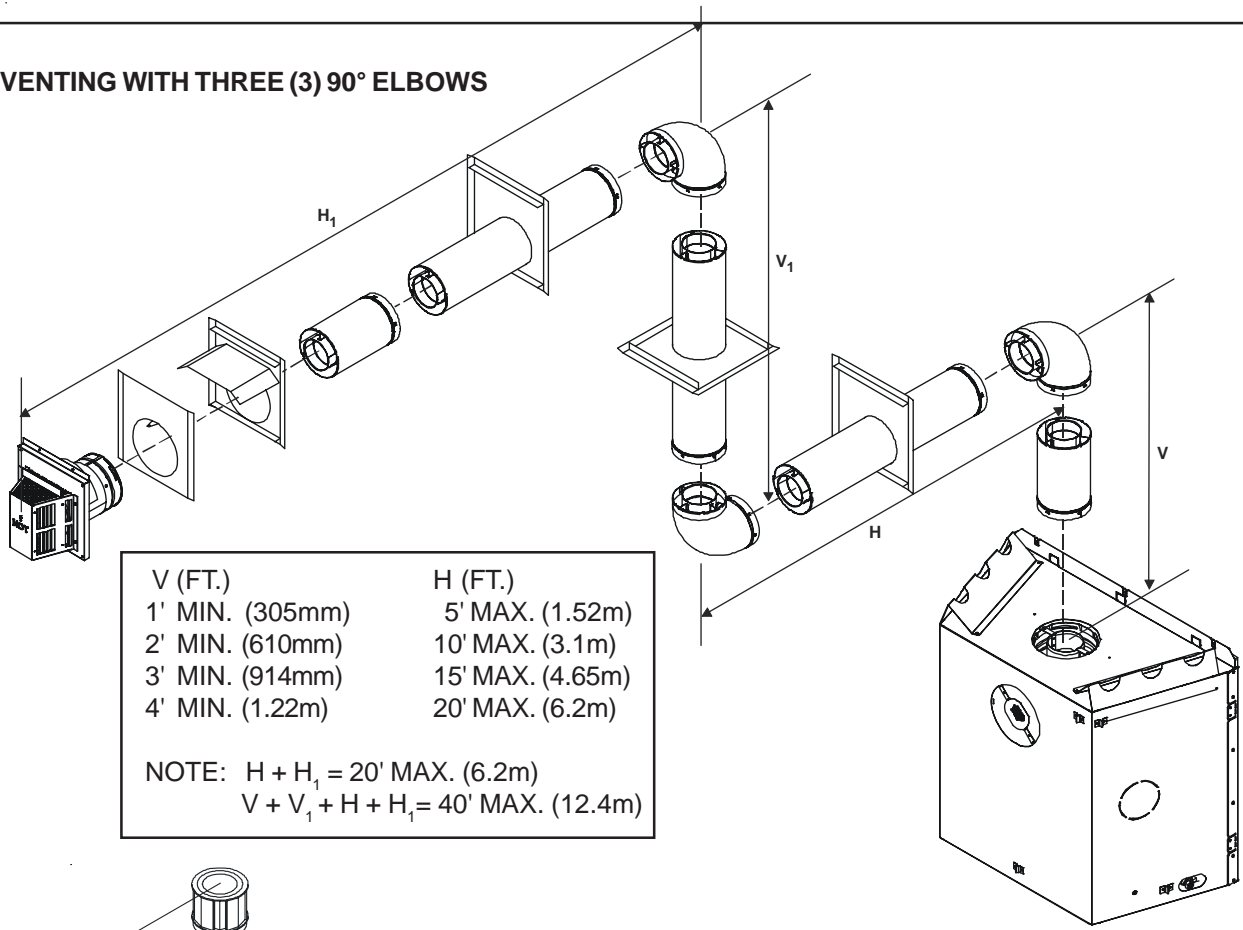

Figure 15. Venting with three 90° elbows

**VENTING WITH THREE (3) 90° ELBOWS**



**Figure 16. Venting with three 90° elbows**

## B. Installing Vent Components

After determining which set of starting collars will be used (top or rear), follow venting instructions accordingly.

### Venting Out the Rear Vent

Remove the installed rear seal cap from the rear starting collars by cutting the strap at each end. (see Figure 17). Follow the vent configuration tables accordingly.

Remove the insulation from the **REAR** five inch flue, pull the heat shield out from outside of the firebox.

**WARNING: THE TOP HEAT SHIELD (INSIDE THE FIREBOX) MUST REMAIN ATTACHED IF THE VENT SYSTEM IS ATTACHED TO THE REAR STARTING COLLARS. SEE FIGURE 17.**

### Venting Out the Top Vent

Remove the two screws in the top vent collar seal cap and remove the top vent collar seal cap and the two pieces of insulation inside the top two starting collars (See Figure 17).

Remove the heat shield from inside the **TOP** five inch flue from outside of the firebox.

You have to take the glass off again for positioning the logs when the unit is finally installed in place and finished around it. Re-install the glass door. Attach vent system to the top starting collars.

**WARNING: THE REAR VENT COLLAR SEAL CAP MUST REMAIN ATTACHED TO THE REAR VENT COLLARS IF THE VENT SYSTEM IS ATTACHED TO THE TOP STARTING COLLARS. SEE FIGURE 18.**

**WARNING: FAILURE TO REMOVE INSULATION IN THE SET OF COLLARS YOU ARE USING COULD CAUSE A FIRE.**

**WARNING: YOU MUST LEAVE THE INSULATION IN PLACE IN THE SET OF COLLARS YOU ARE NOT USING.**

If your vertical vent component is over 10 feet, you may want to install the included vertical baffle to improve flame appearance. Vertical baffle is located in the bag containing the instruction manual. Center the vertical baffle on the five inch flue being used, and with self tapping screws secure the baffle to the inside of the firebox.

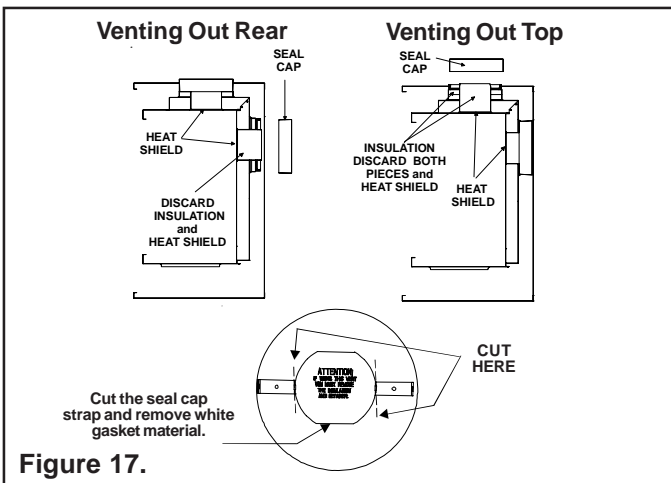

Figure 17.

## 1. Attach the First Vent Component to the Starting Collars

To attach the first vent component to the starting collars of the fireplace:

- Make sure that the fiberglass gasket supplied in the manual bag seals between the first 8 inch (203mm) vent component and the outer fireplace wrap. Using 2 self-tapping screws from the manual bag secure that gasket to the outer wrap (see Figure 18).

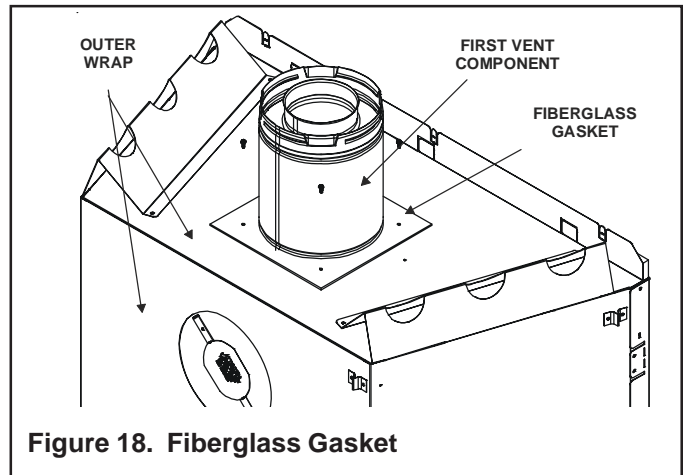

Figure 18. Fiberglass Gasket

## DVP PIPE:

### 1. Attaching the Venting to the Fireplace

Refer to Cinch Pipe and Termination Cap installation instructions.

### 2. Assembling Vent Sections

Refer to Cinch Pipe and Termination Cap installation instructions.

**WARNING: ENSURE THAT THE FIBERGLASS GASKET SUPPLIED WITH THE FIREPLACE SEALS BETWEEN THE FIRST VENT COMPONENT AND THE OUTER FIREPLACE WRAP.**

If the installation is for a termination cap attached directly to the fireplace, skip to the sections, **Install Firestops and Vent Termination.**

### 3. Continue Adding Vent Components

**WARNING: INSTALLATION OF THIS FIREPLACE REQUIRES THE USE OF A HEAT SHIELD ABOVE THE FIRST 90° ELBOW IN THE VENTING SYSTEM.**

**To Install the Heat Shield:**

1. Determine if the heat shield is required. Do so by measuring the vertical distance between the top horizontal surface of the elbow to any combustible surface above. If the distance is more than 4 inches, the heat shield is **NOT** required. If it is 4 inches or less, the heat shield **IS REQUIRED**. Install per the following steps. See Figure 19.

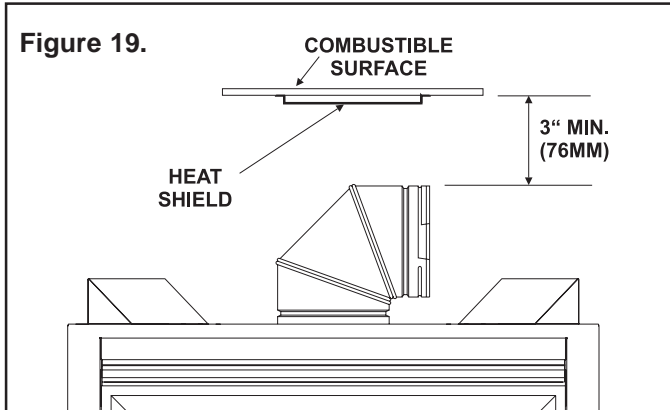

2. Fasten the shield in place using the pilot holes provided in the part. The shield should be oriented such that the 13 1/8 inch dimension (longest dimension) is running in the same direction the elbow is pointing. The shield should be centered directly above the elbow, and positioned so that it creates a 1/2 inch airspace between the shield and the combustible surface. See Figure 20.

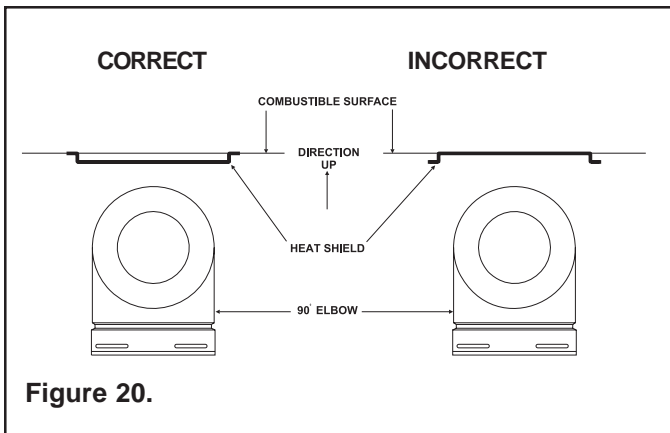

- If the combustible materials are not in place at the time of install the elbow heat shield may be screwed to the exhaust pipe (see Figure 21). Cut the tabs as shown and bend down. Secure the heat shield to the pipe maintaining 3” to 4” between the pipe and shield.

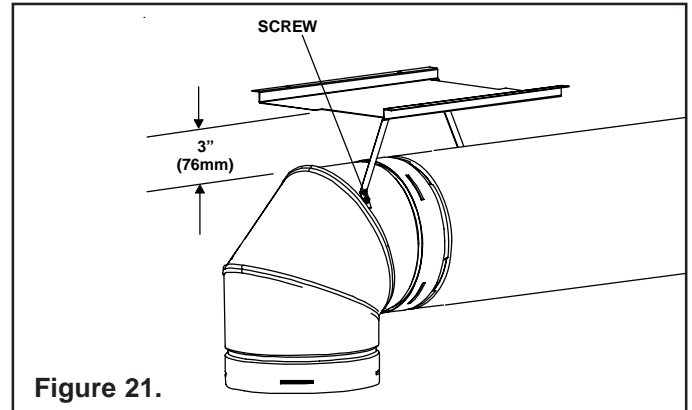

Refer to Cinch Pipe and Termination Cap installation instructions.

- Continue adding vent components, locking each succeeding component into place.
- Ensure that each succeeding vent component is securely fitted and locked into the preceding component in the vent system.
- 90° elbows may be installed and rotated to any point around the preceding component’s vertical axis. If an elbow does not end up in a locked position with the preceding component, attach with a minimum of two (2) sheet metal screws.

**4. Install Support Brackets**

Refer to Cinch Pipe and Termination Cap installation instructions.

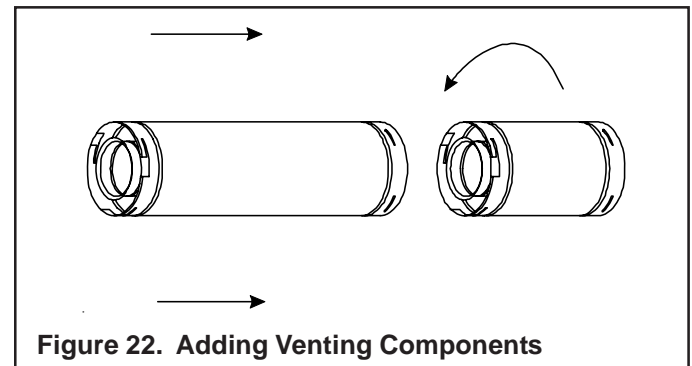

## 5. Install Firestops

**For Horizontal Runs** - Firestops are **REQUIRED** on both sides of a combustible wall through which the vent passes.

**NOTE: Model DVP-TRAP does not need an exterior firestop on an exterior combustible wall.**

To install firestops for horizontal runs that pass through either interior or exterior walls:

- Cut a 10-inch by 12-inch (254mm X 305mm) hole through the wall.

**NOTE: The center of the hole is one (1) inch (25.4mm) above the center of the horizontal vent pipe.**

- Position the firestops on both sides of the hole previously cut and secure the firestops with nails or screws.
- The heat shields of the firestops **MUST BE** placed towards the top of the hole.
- Continue the vent run through the firestops.

**NOTE: There must be NO INSULATION or other combustibles inside the framed firestop opening.**

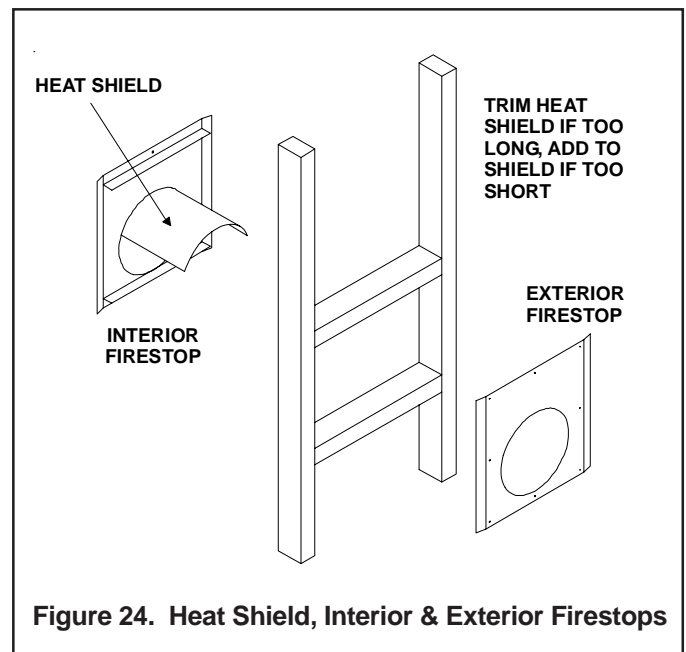
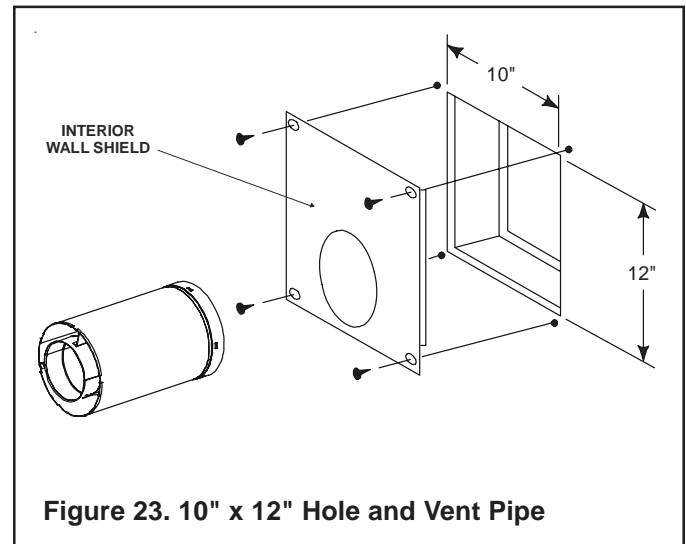



**For Vertical Runs** - One ceiling firestop is **REQUIRED** at the hole in each ceiling through which the vent passes.

To install firestops for vertical runs that pass through ceilings:

- Position a plumb bob directly over the center of the vertical vent component.
- Mark the ceiling to establish the centerpoint of the vent.
- Drill a hole or drive a nail through this centerpoint.
- Check the floor above for any obstructions, such as wiring or plumbing runs.
- Reposition the fireplace and vent system, if necessary, to accommodate the ceiling joists and/or obstructions.
- Cut an 10-inch X 10-inch (254mm X 254mm) hole through the ceiling, using the centerpoint previously marked.
- Frame the hole with framing lumber the same size as the ceiling joists.

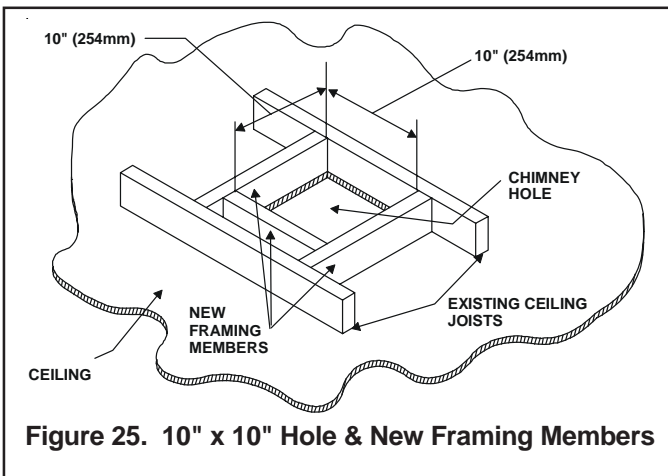

**Figure 25. 10" x 10" Hole & New Framing Members**

If the area above the ceiling is **NOT** an attic, position and secure the ceiling firestop on the ceiling side of the previously cut and framed hole.

**NOTE:** There must be **NO INSULATION** or other combustibles inside the framed firestop opening.

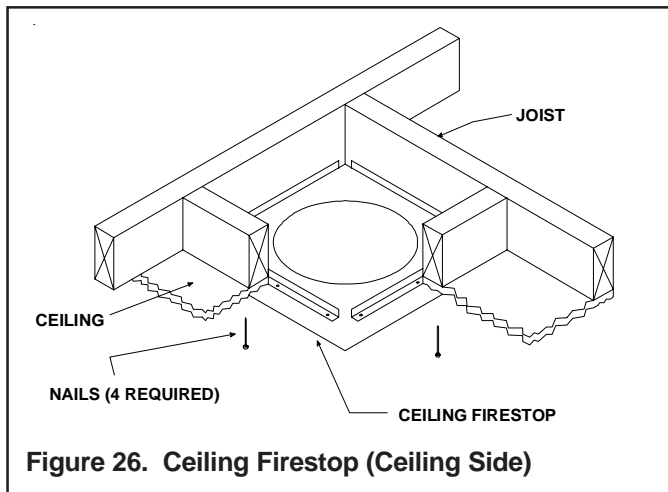

**Figure 26. Ceiling Firestop (Ceiling Side)**

If the area above the ceiling **IS** an attic, position and secure the firestop on top of the previously framed hole.

**NOTE:** Keep insulation away from the vent pipe at least 1 inch (25mm).

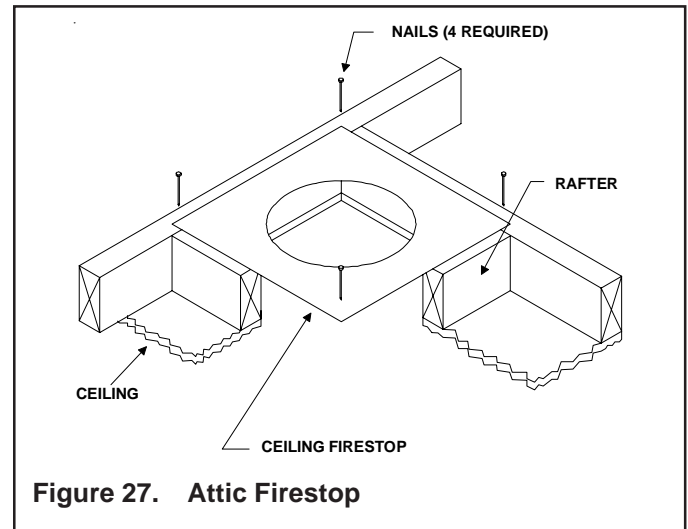

**Figure 27. Attic Firestop**

### C. Vent Termination

Refer to Cinch Pipe and Termination Cap installation instructions.

#### Horizontal Termination

- The termination kit should pass through the wall firestops from the exterior of the building and interlock the flue sections.
- Adjust the termination cap to its final exterior position on the building and interlock the flue sections.

**WARNING:** THE TERMINATION CAP MUST BE POSITIONED SO THAT THE ARROW IS POINTING UP.

**WARNING:** VENTING TERMINALS SHALL NOT BE RECESSED INTO A WALL OR SIDING. VENT TERMINATION CLEARANCES MUST BE FOLLOWED TO AVOID FIRE DANGER. SEE VENT TERMINATION MINIMUM CLEARANCES DIAGRAM ON FOLLOWING PAGE.

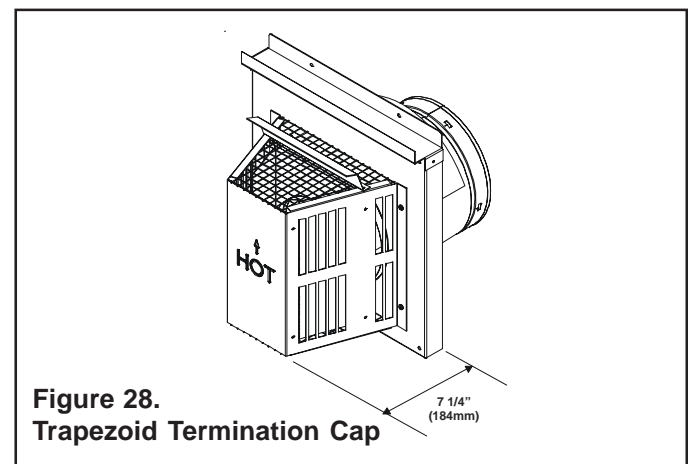

**Figure 28. Trapezoid Termination Cap**

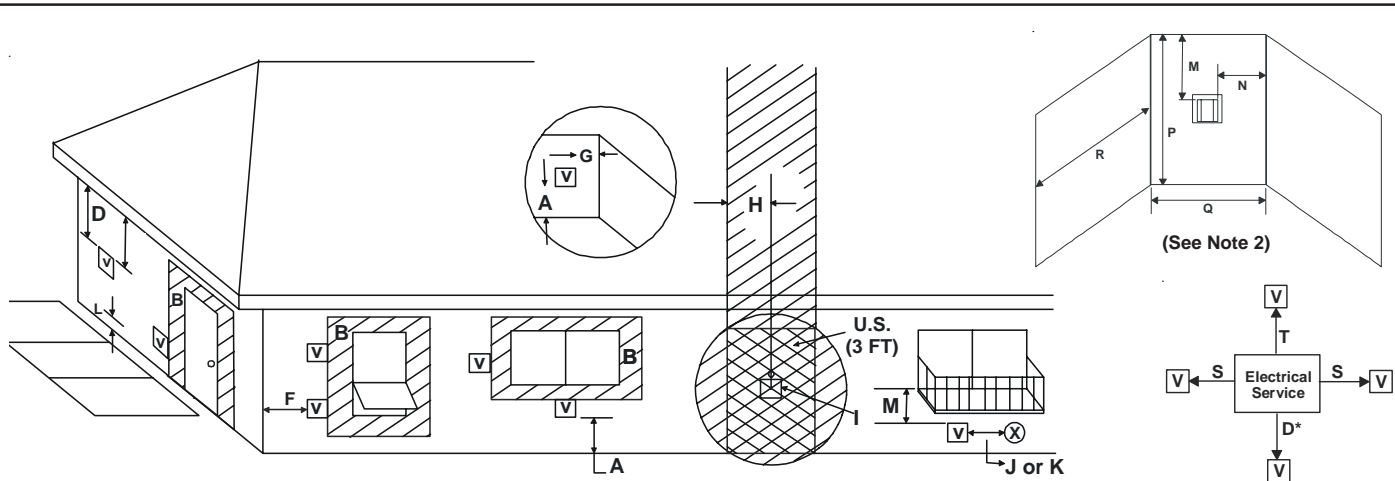

**V** = VENT TERMINAL      **(X)** = AIR SUPPLY INLET      **[Hatched]** = AREA WHERE TERMINAL IS NOT PERMITTED

- |  |  |
|--|--|
| <p>A = 12" ..... clearances above grade, veranda, porch, deck or balcony<br/>(See Note 1)</p> <p>B = 12" ..... clearances to window or door that may be opened, or to permanently closed window.</p> <p>D* = 18" ..... vertical clearance to unventilated soffit or to ventilated soffit located above the terminal</p> <p style="padding-left: 20px;">*30" ..... for vinyl clad soffits and below electrical service</p> <p>F = 9" ..... clearance to outside corner</p> <p>G = 6" ..... clearance to inside corner</p> <p>H = 3 ft. (Canada) ..... not to be installed above a gas meter/regulator assembly within 3 feet (90cm) horizontally from the center-line of the regulator</p> <p>I = 3 ft. (U.S.A.) ..... clearance to gas service regulator vent outlet</p> <p>J = 9" (U.S.A.)<br/>12" (Canada) ..... clearance to non-mechanical air supply inlet to building or the combustion air inlet to any other appliance</p> | <p>K = 3 ft. (U.S.A.)<br/>6 ft. (Canada) ..... clearance to a mechanical air supply inlet</p> <p>L** = 7 ft. ..... clearance above paved sidewalk or a paved driveway located on <u>public</u> property<br/>(See Note 1)</p> <p>M*** = 18" ..... clearance under veranda, porch, deck, balcony or overhang</p> <p style="padding-left: 20px;">42" ..... vinyl soffit and overhang</p> <p>N = 6" ..... non-vinyl sidewalls<br/>12" ..... vinyl sidewalls</p> <p>P = 8 ft.</p> |
|--|--|
- 
- |   | <b>Q<sub>MIN</sub></b> | <b>R<sub>MAX</sub></b>   |
|---|------------------------|--|
| 1 cap   | 3 feet                 | 2 x Q <sub>ACTUAL</sub>  |
| 2 caps  | 6 feet                 | 1 x Q <sub>ACTUAL</sub>  |
| 3 caps  | 9 feet                 | 2/3 x Q <sub>ACTUAL</sub>  |
| 4 caps  | 12 feet                | 1/2 x Q <sub>ACTUAL</sub>  |
| <b>Q<sub>MIN</sub> = # termination caps x 3</b> |                        | <b>R<sub>MAX</sub> = (2 / # termination caps) x Q<sub>ACTUAL</sub></b> |
- 
- |  |
|--|
| <p>S = 6" ..... clearance from sides of electrical service<br/>(See Note 5)</p> <p>T = 12" ..... clearance above electrical service<br/>(See Note 5)</p> |
|--|

\*\* a vent shall not terminate directly above a sidewalk or paved driveway which is located between two single family dwellings and serves both dwellings.

\*\*\* only permitted if veranda, porch, deck or balcony is fully open on a minimum of 2 sides beneath the floor, or meets Note 2.

**NOTE 1:** On private property where termination is less than 7 feet above a sidewalk, driveway, deck, porch, veranda or balcony, use of a listed cap shield is suggested.

**NOTE 2:** Termination in an alcove space (spaces open only on one side and with an overhang) are permitted with the dimensions specified for vinyl or non-vinyl siding and soffits. **1.** There must be 3 feet minimum between termination caps. **2.** All mechanical air intakes within 10 feet of a termination cap must be a minimum of 3 feet below the termination cap. **3.** All gravity air intakes within 3 feet of a termination cap must be a minimum of 1 foot below the termination cap.

**Figure 29. Vent Termination Minimum Clearances**

**NOTE 3:** Local codes or regulations may require different clearances.

**NOTE 4:** Termination caps may be hot. Consider their proximity to doors or other traffic areas.

**NOTE 5:** Location of the vent termination must not interfere with access to the electrical service.

**WARNING: In the U.S:** Vent system termination is **NOT** permitted in screened porches. You must follow side wall, overhang and ground clearances as stated in the instructions.

**In Canada:** Vent system termination is **NOT** permitted in screened porches. Vent system termination is permitted in porch areas with two or more sides open. You must follow all side walls, overhang and ground clearances as stated in the instructions.

Hearth & Home Technologies assumes no responsibility for the improper performance of the fireplace when the venting system does not meet these requirements.

**CAUTION: IF EXTERIOR WALLS ARE FINISHED WITH VINYL SIDING, IT IS SUGGESTED THAT A VINYL PROTECTOR KIT BE INSTALLED.**

**For Vertical Terminations** - To locate the vent and install the vent sections:

- Locate and mark the vent centerpoint on the underside of the roof, and drive a nail through the centerpoint.
- Make the outline of the roof hole around the centerpoint nail.
- The size of the roof hole framing dimensions depend on the pitch of the roof. There **MUST BE** a 1-inch (25.4mm) clearance from the vertical vent pipe to combustible materials.
- Mark the roof hole accordingly.
- Cover the opening of the installed vent pipes.
- Cut and frame the roof hole.
- Use framing lumber the same size as the roof rafters and install the frame securely. Flashing anchored to the frame must withstand heavy winds.
- Continue to install concentric vent sections up through the roof hole (for inside vent installations) or up past the roof line until you reach the appropriate distance above the roof (for outside terminations).

**WARNING: MAJOR U.S. BUILDING CODES SPECIFY MINIMUM CHIMNEY AND/OR VENT HEIGHT ABOVE THE ROOF TOP. THESE MINIMUM HEIGHTS ARE NECESSARY IN THE INTEREST OF SAFETY. SEE FIGURE 30 FOR MINIMUM HEIGHTS, PROVIDED THE TERMINATION CAP IS AT LEAST TWENTY INCHES FROM A VERTICAL WALL AND 2-FEET BELOW A HORIZONTAL OVERHANG.**

**NOTE: This also pertains to vertical vent systems installed on the outside of the building.**

To seal the roof hole, and to divert rain and snow from the vent system:

- Attach a flashing to the roof using nails, and use a non-hardening mastic around the edges of the flashing base where it meets the roof.
- Attach a storm collar over the flashing joint to form a water-tight seal. Place non-hardening mastic around the joint, between the storm collar and the vertical pipe.
- Slide the termination cap over the end of the vent pipe and snap into place.

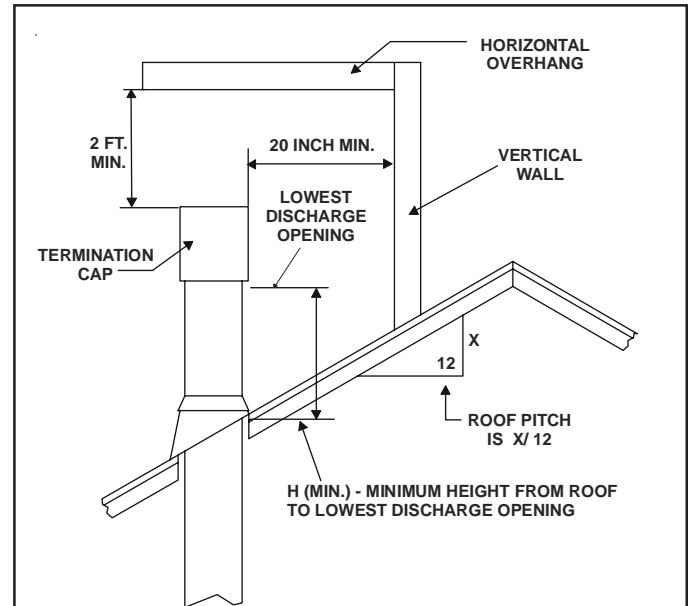

Roof Pitch	H (min.) ft.
flat to 6/12	1.0
6/12 to 7/12	1.25
over 7/12 to 8/12	1.5
over 8/12 to 9/12	2.0
over 9/12 to 10/12	2.5
over 10/12 to 11/12	3.25
over 11/12 to 12/12	4.0
over 12/12 to 14/12	5.0
over 14/12 to 16/12	6.0
over 16/12 to 18/12	7.0
over 18/12 to 20/12	7.5
over 20/12 to 21/12	8.0

**Figure 30. Minimum Height from Roof to Lowest Discharge Opening**

## Step 4. Positioning, Leveling, and Securing the Fireplace

The diagram below shows how to properly position, level, and secure the fireplace.

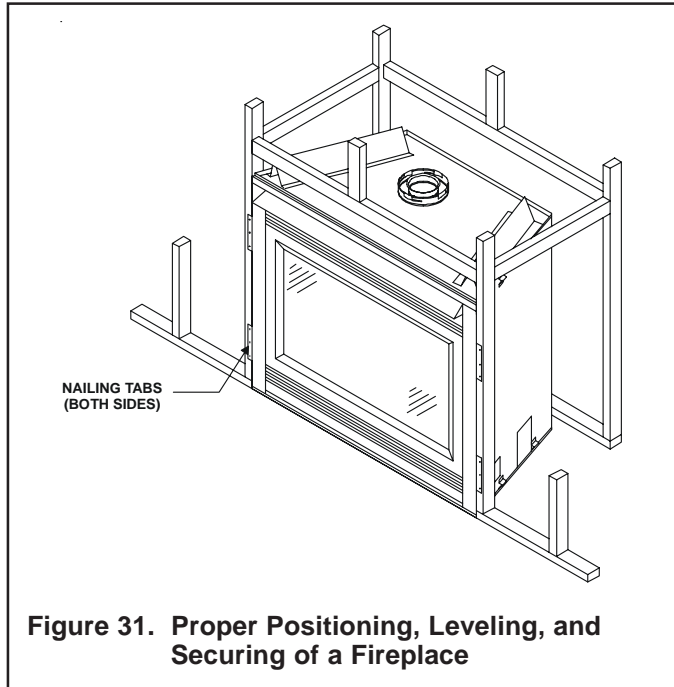

- Place the fireplace into position.
- Level the fireplace from side to side and from front to back.
- Shim the fireplace with non-combustible material, such as sheet metal, as necessary.
- Secure the fireplace to the framing by nailing or screwing.

## Step 5. The Gas Control System



**WARNING: THIS UNIT IS NOT FOR USE WITH SOLID FUEL.**

The type of gas control system used with this model is Standing Pilot Ignition.

### Standing Pilot Ignition System

This system includes millivolt control valve, standing pilot, thermopile/thermocouple flame sensor, and piezo ignitor.



**WARNING: 110-120 VAC MUST NEVER BE CONNECTED TO A CONTROL VALVE IN A MILLIVOLT SYSTEM.**

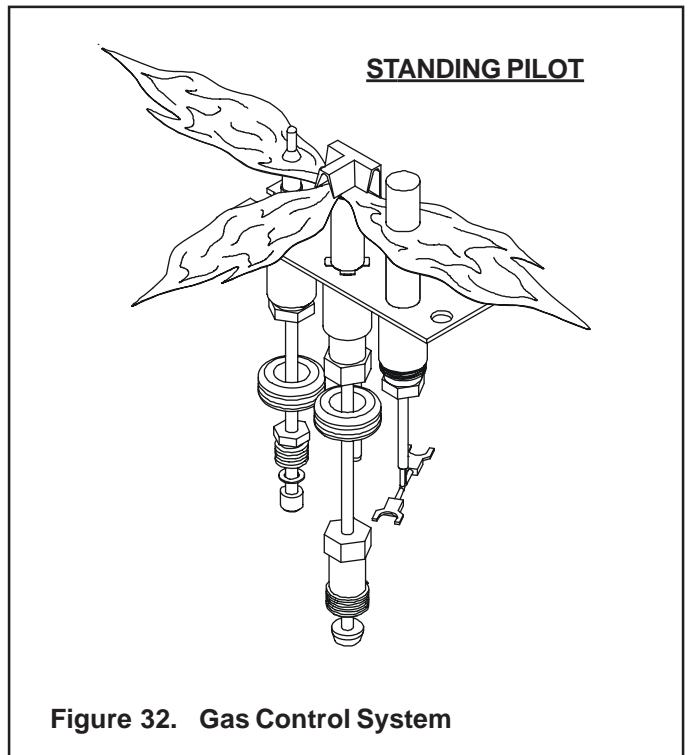

## Step 6. The Gas Supply Line

**NOTE:** Have the gas supply line installed by a qualified service technician in accordance with all building codes. (In the Commonwealth of Massachusetts installation must be performed by a licensed plumber or gas fitter).

**NOTE:** Before the first firing of the fireplace, the gas supply line should be purged of any trapped air.

**NOTE:** Consult local building codes to properly size the gas supply line leading to the 1/2 inch (13 mm) hook-up at the unit.

This gas fireplace is designed to accept a 1/2 inch (13 mm) gas supply line. To install the gas supply line:

- A listed (and Commonwealth of Massachusetts approved) 1/2 inch (13 mm) tee-handle manual shut-off valve and a listed flexible gas connector are connected to the 1/2 inch (13 mm) inlet of the control valve. **NOTE:** If substituting for these components please consult local codes for compliance.
- Locate the gas line access hole in the outer casing of the fireplace.
- The gas line may be run from either side of the fireplace provided the hole in the outer wrap does not exceed 2" in diameter and it does not penetrate the actual firebox.
- Open the fireplace lower grille, insert the gas supply line through the gas line hole, and connect it to the shut-off valve.
- When attaching the pipe, support the control so that the lines are not bent or torn.
- After the gas line installation is complete, all connections must be tightened and checked for leaks with a commercially available, non-corrosive leak check solution. Be sure to rinse off all leak check solution following testing.



**WARNING: DO NOT USE AN OPEN FLAME TO CHECK FOR GAS LEAKS.**

- Insert insulation from the outside of the fireplace and pack the insulation tightly to totally seal between the pipe and the outer casing.
- At the gas line access hole the gap between the supply piping and gas access hole can be plugged with non-combustible insulation to prevent cold air infiltration.

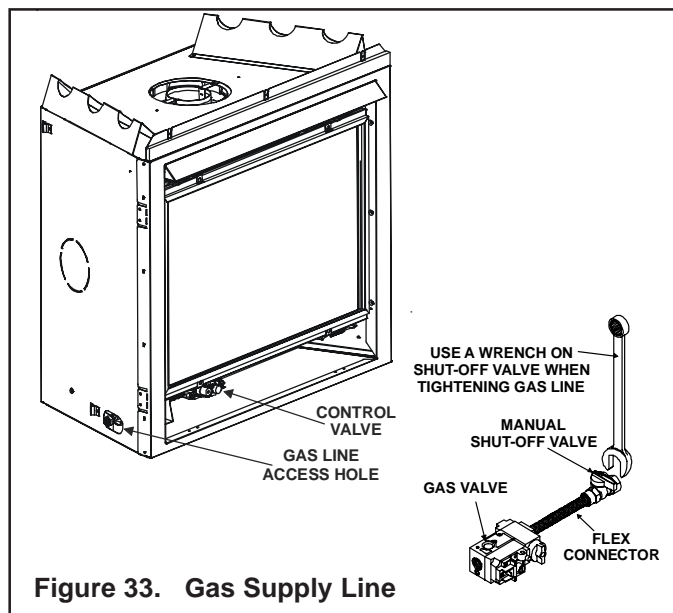

**Figure 33. Gas Supply Line**

## Step 7. Gas Pressure Requirements

Pressure requirements for gas fireplaces are shown in the table below.

Pressure	Natural Gas	Propane
Minimum Inlet Pressure	5.0 inches w.c.	11.0 inches w.c.
Maximum Inlet Gas Pressure	14.0 inches w.c.	14.0 inches w.c.
Manifold Pressure	3.5 inches w.c.	10.0 inches w.c.

A connection is provided on the inlet and outlet side of the gas control for a test gauge connection to measure the manifold pressure. Use a small phillips screwdriver to crack open the screw in the center of the tap. Position a rubber hose over the tap to obtain the pressure reading.

The fireplace and its individual shut-off valve must be disconnected from the gas supply piping system during any pressure testing of the system at test pressures in excess of one-half (1/2) psig (3.5 kPa).

The fireplace must be isolated from the gas supply piping system by closing its individual shut-off valve during any pressure testing of the gas supply piping system at test pressures equal to or less than one-half (1/2) psig (3.5 kPa).

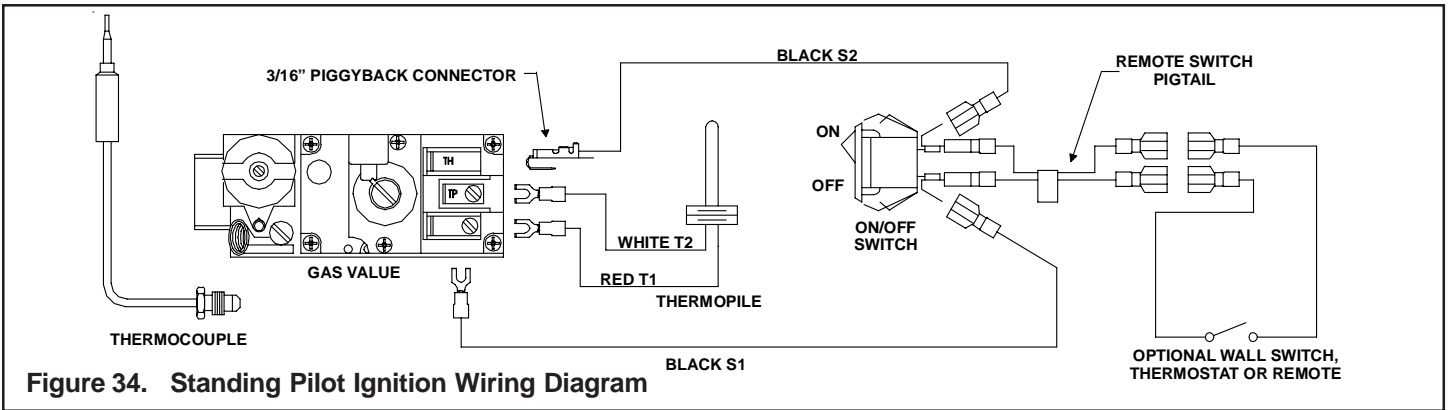

Figure 34. Standing Pilot Ignition Wiring Diagram

### Step 8. Wiring the Fireplace

**NOTE:** Electrical wiring must be installed by a licensed electrician.

**CAUTION:** DISCONNECT REMOTE CONTROLS IF ABSENT FOR EXTENDED TIME PERIODS. THIS WILL PREVENT ACCIDENTAL FIREPLACE OPERATION.

#### Appliance Requirements

- This appliance **DOES NOT** require 110-120 VAC to operate.

**WARNING:** DO NOT CONNECT 110-120 VAC TO THE GAS CONTROL VALVE OR THE APPLIANCE WILL MALFUNCTION AND THE VALVE WILL BE DESTROYED.

#### Optional Accessories

Optional fan and remote control kits require that 110-120 VAC be wired to the factory installed junction box before the fireplace is permanently installed.

#### Wall Switch

Position the wall switch in the desired position on a wall. Run a maximum of 25 feet (7.8 m) or less length of 18 A.W.G. minimum wire and connect it to the fireplace ON/OFF switch pigtails.

**WARNING:** DO NOT CONNECT 110-120 VAC TO THE WALL SWITCH OR THE CONTROL VALVE WILL BE DESTROYED.

**CAUTION:** LABEL ALL WIRES PRIOR TO DISCONNECTION WHEN SERVICING CONTROLS. WIRING ERRORS CAN CAUSE IMPROPER AND DANGEROUS OPERATION. VERIFY PROPER OPERATION AFTER SERVICING.

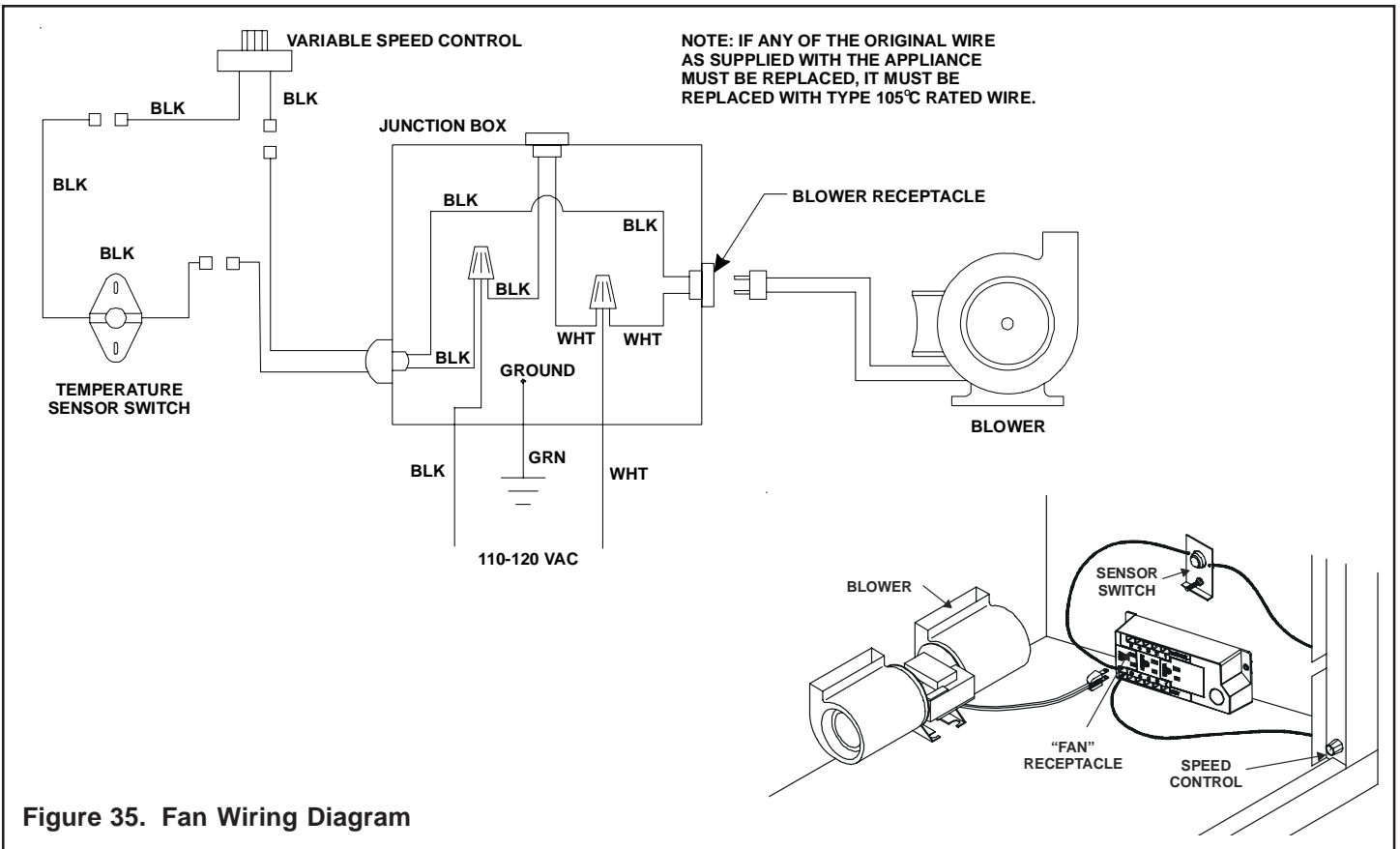

Figure 35. Fan Wiring Diagram



## Step 9. Finishing

Figure 36 shows the minimum vertical and corresponding maximum horizontal dimensions of fireplace mantels or other combustible projections above the top front edge of the fireplace. See Figures 2 and 3 for other fireplace clearances.

Only non-combustible materials may be used to cover the black fireplace front.



**WARNING: WHEN FINISHING THE FIREPLACE, NEVER OBSTRUCT OR MODIFY THE AIR INLET/OUTLET GRILLES IN ANY MANNER.**

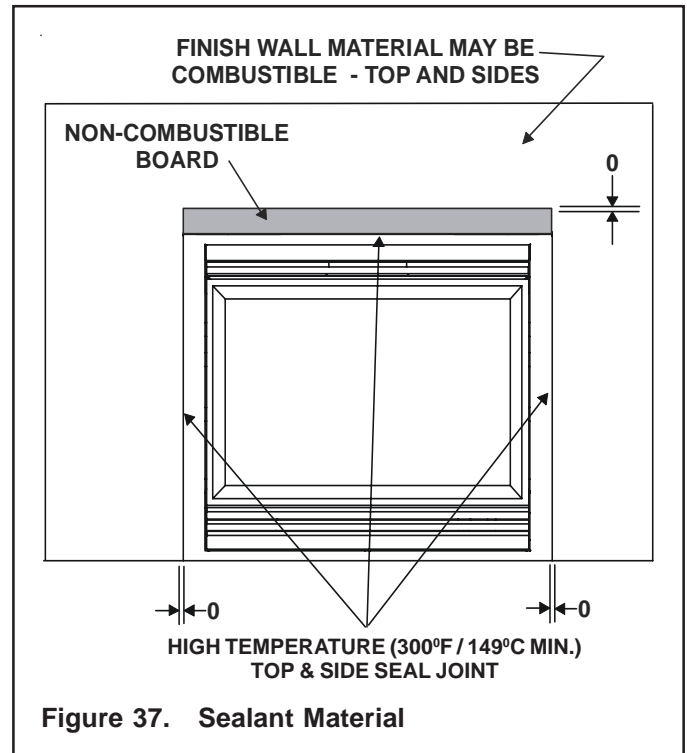
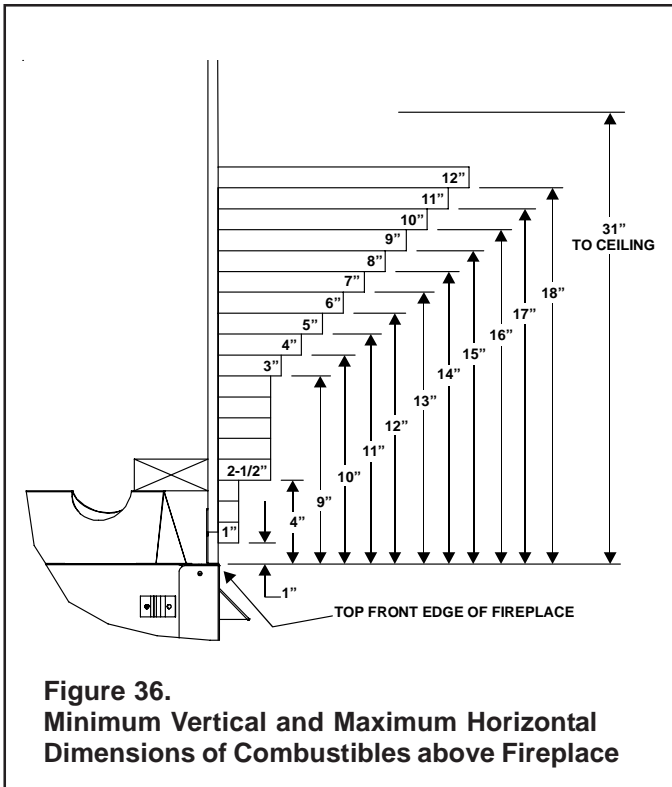

**CAUTION: IF JOINTS BETWEEN THE FINISHED WALLS AND THE FIREPLACE SURROUND (TOP AND SIDES) ARE SEALED, A 300° F. MINIMUM SEALANT MATERIAL MUST BE USED. THESE JOINTS ARE NOT REQUIRED TO BE SEALED. ONLY NON-COMBUSTIBLE MATERIAL (USING 300° F. MINIMUM ADHESIVE, IF NEEDED) CAN BE APPLIED AS FACING TO THE FIREPLACE SURROUND (SEE FIGURE 39).**

### Hearth Extensions

A hearth extension may be desirable for aesthetic reasons. However, ANSI or CAN/CGA testing standards **do not** require hearth extensions for gas fireplace appliances.

**NOTE:** There are 3 metal tabs holding the non-combustible board in place for shipping. These tabs are to be cut off or bent back before finishing around the fireplace front.



## Step 10. Installing Trim, Refractory, Logs, and Ember Material

### Installing the Trim

Combustible materials may be brought up to the specified clearances on the side and top front edges of the fireplace, but **MUST NEVER** overlap onto the front face. The joints between the finished wall and the fireplace top and sides can only be sealed with a 300° F. (149° C) minimum sealant.

**WARNING: WHEN FINISHING THE FIREPLACE, NEVER OBSTRUCT OR MODIFY THE AIR INLET/OUTLET GRILLES IN ANY MANNER.**

Install optional marble and brass trim surround kits as desired. Marble, brass, brick, tile, or other non-combustible materials can be used to cover up the gap between the sheet rock and the fireplace.

Do not obstruct or modify the air inlet/outlet grilles. When overlapping on both sides, leave enough space so that the bottom grille can be lowered and the trim door removed.

### Refractory Kit Placement (BRICK-292)

**CAUTION: REFRACTORY IS FRAGILE! CAREFULLY REMOVE THE REFRACTORY FROM THE PACKAGING.**

Remove the logs and log grate from the fireplace. Place the back wall refractory centered against the back of the fireplace on the back refractory ledge (see Figure 38).

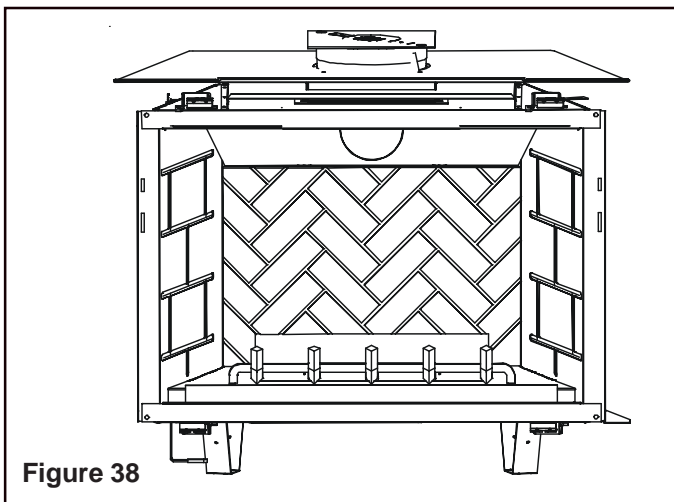

Figure 38

When positioning the left wall use care in not knocking the back wall down. Position the left wall all the way back against the back wall. Using the retaining clip and screw included, secure the side wall refractory as shown (see Figures 39 and 40).

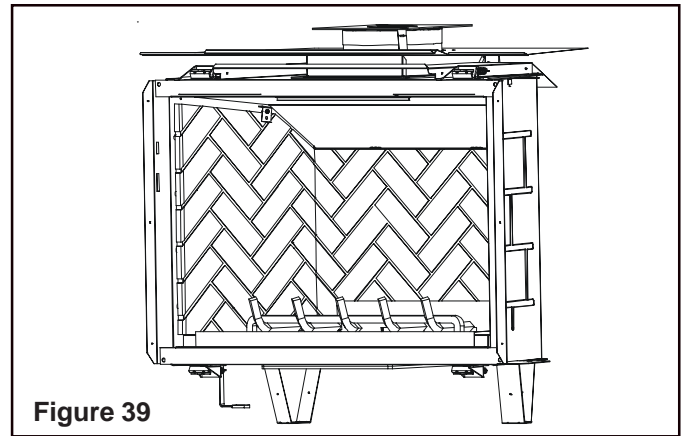

Figure 39



Figure 40

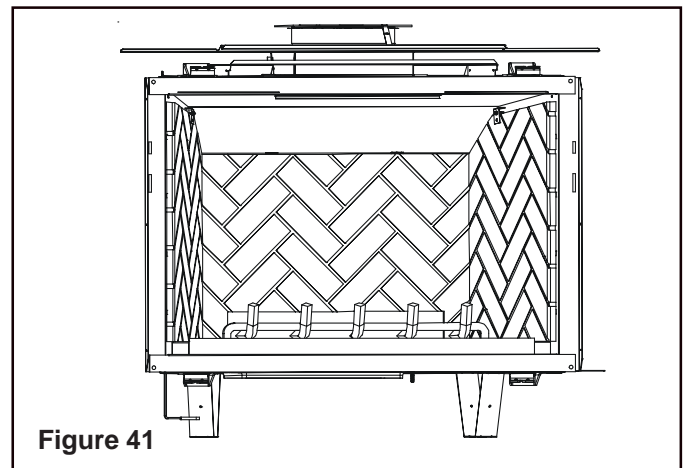

Figure 41

Position the right wall all the way to back wall. Secure in position same as was done for the left wall (see Figure 42).

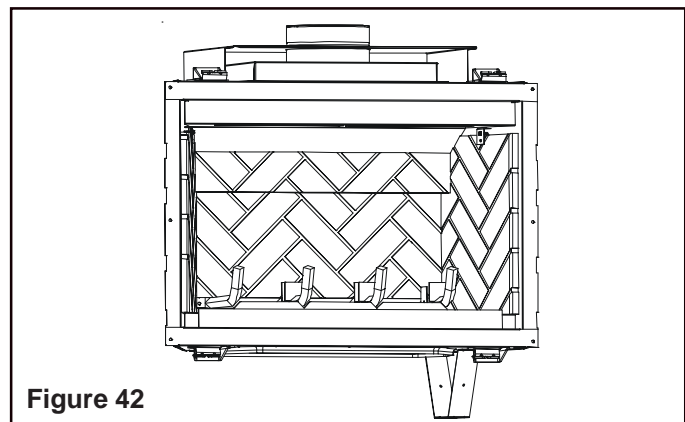

Figure 42

Replace the grate and logs referring to the log instructions.

## Positioning the Logs

Refer to the included log instructions.

## Shutter Settings

	NG	LP
Burner	Full Open	Full Open

## Placing the Ember Material

- Release the four glass latches on the glass frame. Remove glass door from the unit.
- **Glowing Ember** material can be placed without removing logs. Place a single layer of dime size and thickness pieces on exposed area of burner front and burner center. Starting in front of two center logs place one row at a time, completely surrounding all ports in front of middle logs including those that extend under front logs. **DO NOT** press ember material down into ports or place more than a single layer on burner. Do not place embers on or near ports behind front logs.

### **CAUTION: DO NOT COVER BURNER PORTS WITH EMBER MATERIAL.**

- Save the remaining ember materials for use during fireplace servicing.
- Replace the glass door.
- Pull out and latch the glass clips into the glass frame.
- Install a decorative front.

## Glass Specifications: CERAMIC

## Step 11. Before Lighting the Fireplace

**Before** lighting the fireplace, be sure to do the following:

**Remove all paperwork from underneath the fireplace.**

**Check that log retaining rubber bands have been removed!**

### Review safety warnings and cautions

- Read the **Safety and Warning Information** section at the beginning of this *Installers Guide*.

### Double-check for gas leaks

- Before lighting the fireplace, double-check the unit for possible gas leaks.

### Double-check vent terminations and front grilles for obstructions.

- Before lighting the fireplace, double-check the unit for possible obstructions that could be blocking the vent terminations or the front grilles.

### Double-check for faulty components

- Any component that is found to be faulty **MUST BE** replaced with an approved component. Tampering with the fireplace components is **DANGEROUS** and voids all warranties.

A small amount of air will be in the gas supply lines. When first lighting the fireplace, it will take a few minutes for the lines to purge themselves of this air. Once the purging is complete, the fireplace will light and will operate normally.

Subsequent lightings of the fireplace will not require this purging of air from the gas supply lines, **unless the gas valve has been turned to the OFF position**, in which case the air would have to be purged.

**NOTE:** The fireplace should be run 3 to 4 hours on the initial start-up. Turn it off and let it cool completely. Remove and clean the glass. Replace the glass and run the fireplace for an additional 8 hours. This will help to cure the product used in the paint and logs.

During this break-in period it is recommended that some windows in the house be opened for air circulation. This will help avoid setting off smoke detectors, and help eliminate any odors associated with the fireplace's initial burning.

## Step 12. Lighting the Appliance

You've reviewed all safety warnings, you've checked the appliance for gas leaks, you know the vent system is

unobstructed, and you've checked for faulty components. Now you're ready to light the appliance.

### FOR YOUR SAFETY READ BEFORE LIGHTING

**WARNING: IF YOU DO NOT FOLLOW THESE INSTRUCTIONS EXACTLY, A FIRE OR EXPLOSION MAY RESULT CAUSING PROPERTY DAMAGE, PERSONAL INJURY, OR LOSS OF LIFE.**



#### STANDING PILOT IGNITION

- A. This appliance (standing pilot version) has a pilot that must be lighted by hand. When lighting the pilot, follow these instructions exactly.
- B. BEFORE LIGHTING smell all around the appliance area for gas. Be sure to smell next to the floor because some gas is heavier than air and will settle to the floor.

#### WHAT TO DO IF YOU SMELL GAS



- Do not try to light any appliance.
  - Do not touch any electric switch; do not use any phone in your building.
  - Immediately call your gas supplier from a neighbor's phone. Follow the gas supplier's instructions.
  - If you cannot reach your gas supplier, call the fire department.
- C. Use only your hand to push in or turn the gas control knob. Never use tools. If the knob will not push in or turn by hand, don't try to repair it, call a qualified service technician. Force or attempted repair may result in a fire or explosion.
- D. Do not use this appliance if any part has been under water. Immediately call a qualified service technician to inspect the appliance and to replace any part of the control system and any gas control which has been under water.

### LIGHTING INSTRUCTIONS STANDING PILOT CONTROLS

1. To access controls, open the lower grille.
2. Turn the gas control valve knob to the OFF position. To do this, you must turn the knob clockwise  to the PILOT position, and then press in and continue turning clockwise  to the OFF position. **NOTE:** Knob cannot be turned from "PILOT" to "OFF" unless knob is pushed in slightly. Do not force.
3. WAIT AT LEAST FIVE (5) MINUTES TO CLEAR OUT ANY GAS. If you have unsuccessfully tried to light the fireplace, wait longer, especially if you are using LP gas. Then smell for gas, including near the floor. If you then smell gas, **STOP!** Follow "B" in the safety information on previous page. If you don't smell gas, go to the next step.
4. The pilot should not require accessing for lighting purposes. The pilot is located inside the combustion chamber. If it is necessary to access the pilot, remove the trim door and glass door.

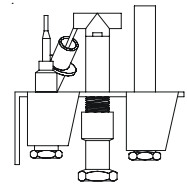
THERMOCOUPLE  
PILOT  
THERMOPILE



5. To put the control in the PILOT position, turn the control knob counter-clockwise  to the PILOT position.
6. To light the pilot press the control knob and then press the red or black piezo button once every second. The piezo makes a clicking sound. It may be necessary to repeat this step. If the pilot does not light after 10 seconds, go back to step 2. The control knob should be held down for a MINUTE after pilot ignition.
  - If the control knob does not pop out when released, **STOP!** Shut off the gas supply to the fireplace control valve, and **IMMEDIATELY** call your service technician or gas supplier.
  - If the pilot will not stay lit after two tries, turn the control knob to the "OFF" position and call your service technician or gas supplier.
7. After the pilot has been lit, the burner can be turned on by turning the knob counter-clockwise  to the "ON" position.
8. Set the ON/OFF switch to the "ON" position.
9. Close the lower grille.

### TO TURN OFF GAS APPLIANCE

1. Open the lower grille.
2. Set ON/OFF switch to "OFF".
3. Turn the valve control knob clockwise  to the "Pilot" position, then depress control knob and continue turning to "OFF" position.
4. Close the lower grille.

When you light your fireplace, you may notice: This gas appliance produces heat which does have an associated odor or smell. If you feel this odor is excessive it may require the initial 3-4 hour continuous burn on high followed by a second burn up to 12 hours to fully drive off any odor from paint and lubricants used in the manufacturing process.

During this break-in period it is recommended that some windows in the house be opened for air circulation. This will help avoid setting off smoke detectors, and help eliminate any odors associated with the fireplace's initial burning.

Additionally, for the first few minutes after each lighting, vapor may condense and fog the glass and flames may be blue. After a few minutes this moisture will disappear and within 15-30 minutes the flames should become yellow.

Noise caused by metal expanding and contracting as it heats up and cools down, similar to the sound produced by a furnace or heating duct. This noise does not affect the operation or longevity of your fireplace.

## Step 13 Climate Control

This model is equipped with a baffle which will allow you to control the usable heat output. The baffle control lever is located at the lower left corner of the unit behind the lower grille.

**TOP VENTED:** More Heat: Pull handle down and push back to close the damper. Less Heat: Pull handle forward and push up to open the damper.

**REAR VENTED:** More Heat: Pull handle forward and push up to close the damper. Less Heat: Pull handle down and push back to open the damper.

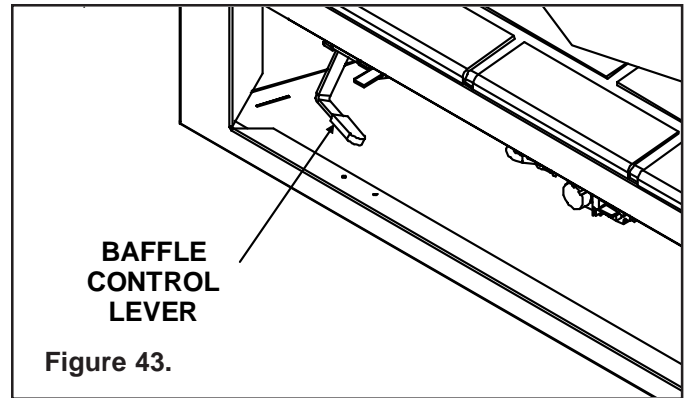

### After the Installation



**LEAVE THIS INSTALLATION MANUAL WITH THE APPLIANCE FOR FUTURE REFERENCE.**

# 4 Maintaining and Servicing Your Fireplace

## Fireplace Maintenance

Although the frequency of your fireplace servicing and maintenance will depend on use and the type of installation, you should have a qualified service technician perform an appliance check-up at the beginning of each heating season. See the table below for specific guidelines regarding each fireplace maintenance task.

**IMPORTANT: TURN OFF THE GAS BEFORE SERVICING YOUR FIREPLACE.**

### Replacing old ember material

**Frequency:** Once annually, during the checkup.

**By:** Qualified service technician.

**Task:** Brush away loose ember material near the burner. Replace old ember material with new dime-size and shape pieces. New ember material should be placed on top of the burner. Save the remaining ember material and repeat this procedure at your next servicing. For more information, see **Placing Ember Material**.

### Cleaning Burner and Controls

**Frequency:** Once annually.

**By:** Qualified service technician.

**Task:** Brush or vacuum the control compartment, fireplace logs and burner areas surrounding the logs.

### Checking Flame Patterns, Flame Height

**Frequency:** Periodically.

**By:** Qualified service technician/Home owner.

**Task:** Make a visual check of your fireplace's flame patterns. Make sure the flames are steady - not lifting or floating. See Figure 44. The thermopile/thermocouple tips should be covered with flame (See Figure 32).

### Checking Vent System

**Frequency:** Before initial use and at least annually thereafter, more frequently if possible.

**By:** Qualified service technician/Home owner.

**Task:** Inspect the external vent cap on a regular basis to ensure that no debris is interfering with the flow of air. Inspect entire vent system for proper function.

### Cleaning Glass Door

**Frequency:** After the first 3 to 4 hours of use. As necessary after initial cleaning.

**By:** Home owner.

**Task:** Remove and clean glass after the first 3 to 4 hours of use. After the initial cleaning, clean as necessary, particularly after adding new ember (flame colorant) material. Film deposits on the inside of the glass door should be cleaned off using a household glass cleaner. **NOTE: DO NOT handle or attempt to clean the door when it is hot and DO NOT use abrasive cleaners.**

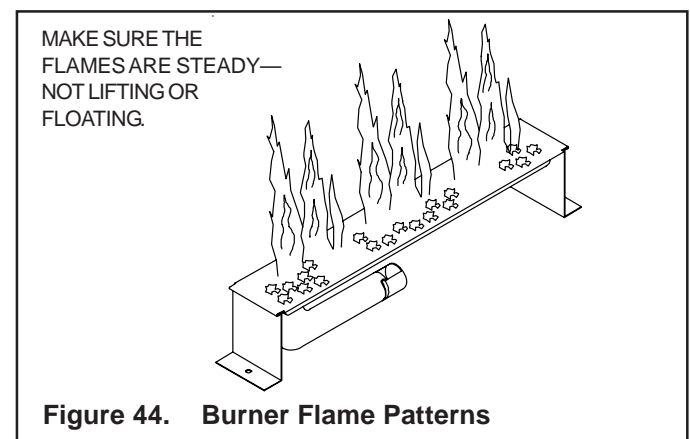

# 5

## Troubleshooting

With proper installation, operation, and maintenance your gas fireplace will provide years of trouble-free service. If you do experience a problem, this troubleshooting guide will assist a qualified service person in the diagnosis of a problem and the corrective action to be taken. This troubleshooting guide can only be used by a qualified service technician.

Symptom	Possible Cause	Corrective Action
1. After repeated triggering of the red or black piezo button, the spark ignitor will not light the pilot.	a. Defective ignitor.	Check the spark at the electrode and pilot. If no spark and electrode wire is properly connected, replace the ignitor.
	b. Defective pilot or misaligned electrode (spark at electrode).	Using match, light the pilot. If the pilot lights, turn off the pilot and trigger the red or black piezo button again. If the pilot lights, an improper gas/air mixture caused the bad lighting and a longer purge period is recommended. If the pilot will not light, ensure the the gap at the electrode and pilot is one-eighth (1/8) inch to have a strong spark. If the gap is OK, replace the pilot.
	c. No gas or low gas pressure.	Check the remote shut-off valvess from the fireplace. Usually, there is a valve near the gas main. There can be more than one (1) valve between the fireplace and the main.
	d. No LP in tank.	Check the LP (propane) tank. You may be out of fuel.
2. The pilot will not stay lit after carefully following the lighting instructions.	a. Defective thermocouple.	Check that the pilot flame impinges on the thermocouple. Clean and/or adjust the pilot for maximum flame impingement.  Ensure that the thermocouple connection at the gas valve is fully inserted and tight (hand tighten plus 1/4 turn).  Disconnect the thermocouple from the valve, place one millivolt meter lead wire on the tip of the thermcouple and the other meter lead wire on the thermocouple copper lead. Start the pilot and hold the valve knob in. If the millivolt reading is less than 15mV, replace the thermocouple.
	b. Defective valve.	If the thermocouple is producing more than 15 millivolts, replace faulty valve.
3. The pilot is burning, there is no gas burner, the valve knob is in the ON position, and the ON/OFF switch is in the ON position.	a. ON/OFF switch or wires defective.	Check the ON/OFF switch and wires for proper connections. Place the jumper wires across the terminals at the switch. If the burner comes on, replace the defective switch. If the switch is OK, place the jumper wires across the switch wires at the gas valve. If the burner comes on, the wires are faulty or connections are bad.
	b. Thermopile may not be generating sufficient millivoltage.	If the pilot flame is not close enough physically to the thermopile, adjust the pilot flame.  Be sure the wire connections from the thermopile at the gas valve terminals are tight and that the thermopile is fully inserted into the pilot bracket.  Check the thermopile with a millivolt meter. Take the reading at TH-TP&TP terminals of the gas valve. The meter should read 325 millivolts minimum, while holding the valve knob depressed in the pilot position, with the pilot lit, and the ON/OFF switch in the OFF position. Replace the faulty thermopile if the reading is below the specified minimum.  With the pilot in the ON position, disconnect the thermopile leads from the valve. Take a reading at the thermopile leads. The reading should be 325 millivolts minimum. Replace the thermopile if the reading is below the minimum.
	c. Defective valve.	Turn the valve knob to the ON position. Place the ON/OFF switch in the ON position. Check the millivolt meter a the thermopile terminals. The millivolt meter should read greater than 125mV. If the reading is acceptable, and if the burner does not come on, replace the gas valve.
	d. Plugged burner orifice.	Check the burner orifice for stoppage. Remove stoppage.
	e. Wall switch or wires are defective.	Follow the corrective action in Symptom and Possible Cause 1.a above. Check the switch and wiring. Replace where defective.



## Troubleshooting *(continued)*

Symptom	Possible Cause	Corrective Action
3. (Continued)	f. High limit switch is defective or has reached its maximum temperature.	Allow the unit to cool. If the burner remains lit after the fireplace warms up, the switch is good.
4. Frequent pilot outage problem.	a. Pilot flame may be too high or too low, or blowing (high), causing pilot safety to drop out.	Clean and adjust the pilot flame for maximum flame impingement on thermocouple. Follow lighting instructions carefully.
5. The pilot and main burner extinguish while in operation.	a. No LP in tank.	Check the LP (propane) tank. Refill the fuel tank.
	b. Inner vent pipe leaking exhaust gases back into the system.	Check for gas leaks.
	c. Horizontal vent improperly pitched.	The horizontal vent cap should slope down only enough to prevent any water from entering the unit. The maximum downwards lope is 1/4 inch.
	d. Glass too loose and air tight packet leaks in corners after usage.	Tighten the corner.
	e. Bad thermopile or thermocouple.	Replace if necessary.
	f. Improper vent cap installation.	Check for proper installation and freedom from debris or blockage.
6. Glass soots.	a. Flame impingement.	Adjust the log set so that the flame does not excessively impinge on it.
	b. Improper venturi setting.	Adjust the air shutter at the base of the burner.
	c. Debris around venturi.	Inspect the opening at the base of the burner. <b>NO MATERIAL SHOULD BE PLACED IN THIS OPENING.</b>
7. Flame burns blue and lifts off burner.	a. Insufficient oxygen being supplied.	<p>Ensure that the vent cap is installed properly and free of debris. Ensure that the vent system joints are tight and have no leaks.</p> <p>Ensure that no debris has been placed at the base of, or in the area of the air holes in the center of the base pan beneath the burner.</p> <p>Ensure that the glass is tightened properly on the unit, particularly on top corners.</p>

# Lifetime Warranty

## LIMITED LIFETIME WARRANTY

The Hearth & Home Technologies limited Lifetime Warranty guarantees that the following components will work as designed for the lifetime of the stove or Hearth & Home Technologies will repair or replace them. These items include but are not limited to steel and cast iron components, all gas burners, gas logs, combustion chambers, heat exchanger systems, stainless steel firebox components, plating, doors, glass damaged by thermal breakage, steel baffle supports, steel and ceramic baffles and manifold tubes. Labor is for the first five years.

## THREE YEAR WARRANTY

Our EZ Clean firepots are covered under Hearth & Home Technologies three-year warranty program. Labor is for 3 years.

## TWO YEAR WARRANTY

All electrical components such as but not limited to blowers, wiring, vacuum switches, speed controls, control boxes, thermodisc switches, pilot assembly, gas valves, thermostats and remotes are covered under Hearth & Home Technologies two-year warranty program.

## ONE YEAR WARRANTY

Porcelain finishes are warranted against manufacturer defects for one year. Labor to repair or replace these parts is covered for one year, reimbursed per our warranty service fee schedule.

## CONDITIONS

This warranty is non-transferable and is made to the original retail purchaser only provided that the purchase was made through an authorized dealer of Hearth & Home Technologies It must be installed and operated at all times in accordance with the Installation and Operating Instructions furnished with this product, as well as any applicable local and national codes. Any alteration, willful abuse, accident, or misuse of the product shall nullify this warranty.

Labor to repair or replace items covered under the limited Lifetime Warranty will be covered for the first five years per our warranty service fee reimbursement schedule. Parts covered under the limited Lifetime Warranty will be covered for the lifetime of the appliance up to a maximum of ten (10) years after Hearth & Home Technologies discontinues the model and two (2) years for optional accessories. Adjustments, regular maintenance, cleaning and temporary repairs do not qualify for a service call fee and will not be covered. The replacement of consumer replaceable items and installation of upgraded component parts do not qualify for a service call fee, and will not be covered.

This limited Lifetime Warranty does not extend to or include surface finish on the appliance, door gasketing, glass gasketing, firebrick, kaowool or other ceramic insulating materials. It does not cover installation or operational-related problems such as overfiring, use of corrosive driftwood, downdrafts or spillage caused by environmental conditions, nearby trees, buildings, hilltops, mountains, inadequate venting or ventilation, excessive offsets, or negative air pressures caused by mechanical systems such as furnaces, fans, clothes dryers, etc.

Any installation, construction, transportation, or other related costs or expenses arising from defective part(s), repair, replacement, etc., will not be covered by this warranty, nor will Hearth & Home Technologies assume responsibility for them. Further, Hearth & Home Technologies will not be responsible for any incidental, indirect, or consequential damages, except as results in damage to the interior or exterior of the building in which this appliance is installed. This limited Lifetime Warranty does not apply to the venting components, hearth components or other accessories used in conjunction with the installation of this product not manufactured by Hearth & Home Technologies

This warranty is void if the stove has been overfired or operated in atmospheres contaminated by chlorine, fluorine, or other damaging chemicals, the stove is subjected to prolonged periods of dampness or condensation, or there is any damage to the stove or other components due to water or weather damage which is the result of, but not limited to, improper chimney or venting installation. Hearth & Home Technologies may, at its discretion, fully discharge all obligations with respect to this warranty by either repairing or replacing the unit, or refunding the wholesale price of the defective part(s).

This limited Lifetime Warranty is effective on all appliances sold after May 1, 2002 and supersedes any and all warranties currently in existence.





→ **Contact Information**



Quadra-Fire, a brand of Hearth & Home Technologies Inc.  
20802 Kensington Boulevard, Lakeville, MN 55044  
www.quadrafire.com

Please contact your Quadra-Fire dealer with any questions or concerns.  
For the location of your nearest Quadra-Fire dealer,  
please visit [www.quadrafire.com](http://www.quadrafire.com).

**- NOTES -**

---

---

---

---

---

---

---

---

---

---

**CAUTION**



**DO NOT DISCARD THIS MANUAL**

- Important operating and maintenance instructions included.
- Read, understand and follow these instructions for safe installation and operation.
- Leave this manual with party responsible for use and operation.



This product may be covered by one or more of the following patents: (United States) 4593510, 4686807, 4766876, 4793322, 4811534, 5000162, 5016609, 5076254, 5113843, 5191877, 5218953, 5263471, 5328356, 5341794, 5347983, 5429495, 5452708, 5542407, 5601073, 5613487, 5647340, 5688568, 5762062, 5775408, 5890485, 5931661, 5941237, 5947112, 5996575, 6006743, 6019099, 6048195, 6053165, 6145502, 6170481, 6237588, 6296474, 6374822, 6413079, 6439226, 6484712, 6543698, 6550687, 6601579, 6672860, 6688302B2, 6715724B2, 6729551, 6736133, 6748940, 6748942, 6769426, 6774802, 6796302, 6840261, 6848441, 6863064, 6866205, 6869278, 6875012, 6880275, 6908039, 6919884, D320652, D445174, D462436; (Canada) 1297749, 2195264, 2225408, 2313972; (Australia) 780250, 780403, 1418504 or other U.S. and foreign patents pending.

Printed in U.S.A. - Copyright 2007