

# Outdoor Gas Fireplace Installation & Operating Instructions

Models: ODGSR36A, ODGSR42A

## INSTALLER/CONSUMER SAFETY INFORMATION

**PLEASE READ THIS MANUAL  
BEFORE INSTALLING AND USING  
APPLIANCE.**

**WARNING:** If the information in this manual is not followed exactly, a fire or explosion may result causing property damage, personal injury or loss of life.

— Do not store or use gasoline or other flammable vapors and liquids in the vicinity of this or any other appliance

### — WHAT TO DO IF YOU SMELL GAS

- Do not try to light any appliance.
- Do not touch any electrical switch; do not use any phone in your building.
- Immediately call your gas supplier from a neighbor's phone. Follow the gas supplier's instructions.
- If you cannot reach your gas supplier, call the fire department.

— Installation and service must be performed by a qualified installer, service agency or the gas supplier.

**WARNING:** Improper installation, adjustment, alteration, service or maintenance can cause injury or property damage. Read the installation, operating and maintenance instructions thoroughly before installing or servicing this equipment.

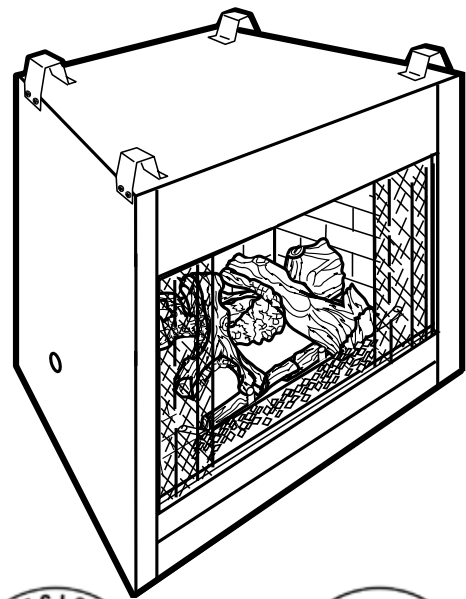

### **WARNING!**

For Outdoor Use Only.

**INSTALLER:** Leave this manual with the appliance.  
**CONSUMER:** Retain this manual for future reference.

Installation and service of this appliance should be performed by qualified personnel. Hearth & Home Technologies recommends HHT Factory Trained or NFI certified professionals.



# Table of Contents

Thank you and Congratulations on your purchase of a Outdoor Lifestyles fireplace.

**PLEASE READ THE INSTALLATION & OPERATING INSTRUCTIONS BEFORE USING THE APPLIANCE**

**IMPORTANT: Read all instructions and warnings carefully before starting installation. Failure to follow these instructions may result in a possible fire hazard and will void the warranty.**

<b>Installation &amp; Operating Instructions</b> .....	3
General Information.....	3
Fireplace Dimensions.....	4
Moisture Resistance.....	5
Screened Porch Installation .....	5
Clearance to Combustibles .....	5
Mantels .....	5
Hearth .....	5
Moisture Resistance.....	6
Framing & Finishing .....	6
Final Finishing .....	6
Gas Specifications.....	7
Gas Inlet & Manifold Pressures.....	7
High Elevations .....	7
Valve Access .....	7
Exterior Chase Installation .....	8
Gas Line Installation.....	8
Remote Wall Switch .....	9
<b>Operating Instructions</b> .....	
Log Installation .....	10
First Firing .....	10
Flame Adjustment.....	11
Flame Characteristics.....	11
Optional Weather Enclosures.....	12
Optional Stainless Steel Hood.....	12
Lighting & Operating Instructions .....	13
Troubleshooting.....	14
<b>Maintenance</b> .....	15
<b>Replacement Parts</b> .....	16
<b>Accessories</b> .....	18
<b>Warranty</b> .....	19

**IMPORTANT:**

**PLEASE READ THE FOLLOWING CAREFULLY**

Remove any plastic from trim parts before turning the fireplace "ON".

It is normal for fireplaces fabricated of steel to give off some expansion and/or contraction noises during the start up or cool down cycle. Similar noises are found with your furnace heat exchanger or car engine.

It is not unusual for your Outdoor Lifestyles Fireplaces gas fireplace to give off some odor the first time it is burned. This is due to the curing of the paint and any undetected oil used in the manufacturing process.

It is recommended that you burn your fireplace for at least ten (10) continuous hours the first time you use it.

**Proposition 65 Warning:** Fuels used in gas, woodburning or oil fired appliances, and the products of combustion of such fuels, contain chemicals known to the State of California to cause cancer, birth defects and other reproductive harm.

California Health & Safety Code Sec. 25249.6

## General Information

This gas appliance should be installed by a qualified installer in accordance with local building codes and with current **CSA-B149.1** Installation codes for Gas Burning Appliances and Equipment.

FOR U.S.A Installations follow local codes and/or the current **National Fuel Gas Code. ANSI Z223.1/NFPA 54.**

In the Commonwealth of Massachusetts, all gas fittings and installation of this heater shall only be done by a licensed gas fitter or licensed plumber.

### FOR SAFE INSTALLATION AND OPERATION PLEASE NOTE THE FOLLOWING:

1. This appliance gives off high temperatures and should be located out of high traffic areas and away from furniture.
2. Children and adults should be alerted to the hazards of the high surface temperatures of this appliance and should stay away to avoid burns or ignition of clothing.
3. Children should be carefully supervised when they are in the same room as your appliance.
4. Under no circumstances should this appliance be modified. Parts having to be removed for servicing should be replaced prior to operating this appliance again.
5. Installation and any repairs to this appliance should be carried out by a qualified service person. A professional service person should be contacted to inspect this appliance annually. Make it a practice to have all of your gas appliances checked annually. More frequent cleaning may be required due to excess lint and dust from carpeting, bedding material, etc.
6. Control compartments, burners and air passages in this appliance should be kept clean and free of dust and lint. Make sure that the gas valve and pilot light are turned off before you attempt to clean this unit.
7. Keep the area around your appliance clear of combustible materials, gasoline and other flammable vapor and liquids. This appliance should not be used as a drying rack for clothing, nor should Christmas stockings or decorations be hung in the area of it.
8. Under no circumstances should any solid fuels (wood, coal, paper or cardboard etc.) be used in this appliance.
9. The flow of combustion and ventilation air must not be obstructed in any way.
10. Whether the appliance is installed directly on carpeting, vinyl tile or any combustible material other than wood, this appliance must be installed on a metal or wood panel extending the full width and depth of the appliance.
11. This appliance requires adequate ventilation and combustion air to operate properly.
12. Do not use this appliance if any part has been under water. Immediately call a qualified service technician to inspect the appliance and to replace any part of the control system or gas control that has been under water.
13. Inspect the burner before each use of the appliance. The burner must be replaced prior to operation if there is evidence the burner is damaged. Use only burner specified by manufacturer.

LP-cylinder enclosures, if provided by the consumer must conform to the design parameters as detailed below.

### Enclosures for LP-Gas Supply Systems

Enclosures for LP-gas supply cylinders shall be ventilated by openings at the level of the cylinder valve and at floor level. The effectiveness of the opening(s) for purposes of ventilation shall be determined with the LP-gas supply cylinder(s) in place. This shall be accomplished by one of the following:

- a. One side of the enclosure shall be completely open; or
- b. For an enclosure having four sides, a top and a bottom:
  1. At least two ventilation openings at cylinder valve level shall be provided in the side wall, equally sized, spaced at 180 degrees (3.14rad), and unobstructed. Each opening shall have a total free area of not less than 1/2 square inch per pound (3.2 sq. cm/kg) of stored fuel capacity and not less than a total free area of 10 square inches (64.5 sq. cm).
  2. Ventilation opening(s) shall be provided at floor level and shall have a total free area of not less than 1/2 square inch per pound (3.2 sq. cm/kg) of stored fuel capacity and not less than a total free area of 10 square inches (64.5 sq. cm). If ventilation openings at floor level are in a side all, there shall be at least two openings. The bottom of the openings shall be at floor level and the upper edge no more than 5 inches (127 mm) above the floor. The openings shall be equally sized, spaced at 180 degrees (3.14 rad) and unobstructed.
  3. Every opening shall have minimum dimensions so as to permit the entrance of a 1/8 inch (3.2 mm) diameter rod.

Cylinder valves shall be readily accessible for hand operation. A door on the enclosure to gain access to the cylinder valves is acceptable, provided it is non-locking and can be opened without the use of tools.

There shall be a minimum clearance of 2 inches (51 mm) between the lower surface of the floor of the LP-gas supply cylinder enclosure and the ground.

The design of the appliance shall be such that (1) the LP-gas supply cylinder(s) can be connected, disconnected and the connections inspected and tested outside the cylinder enclosure; and (2) those connections which could be disturbed when installing the cylinder(s) in the enclosure can be leak tested inside the enclosure.

### Description

The ODGSR Series are radiant fireplaces. Do not burn wood or other materials in these appliances. Each model is available with standing pilot for use with Natural or Propane gas units.

Report to your dealer any parts damaged in shipment.

Adequate combustion and ventilation air must be provided. The flow of combustion and ventilation air **MUST NOT** be obstructed.

Provide adequate clearances around the air opening into the combustion chamber; and adequate accessibility clearance for servicing and proper operation. **NEVER** obstruct the front opening of the appliance.

**This fireplace is not designed to be water tight. Therefore, when installing this unit against an exterior wall, the wall must be finished before setting unit in place.**

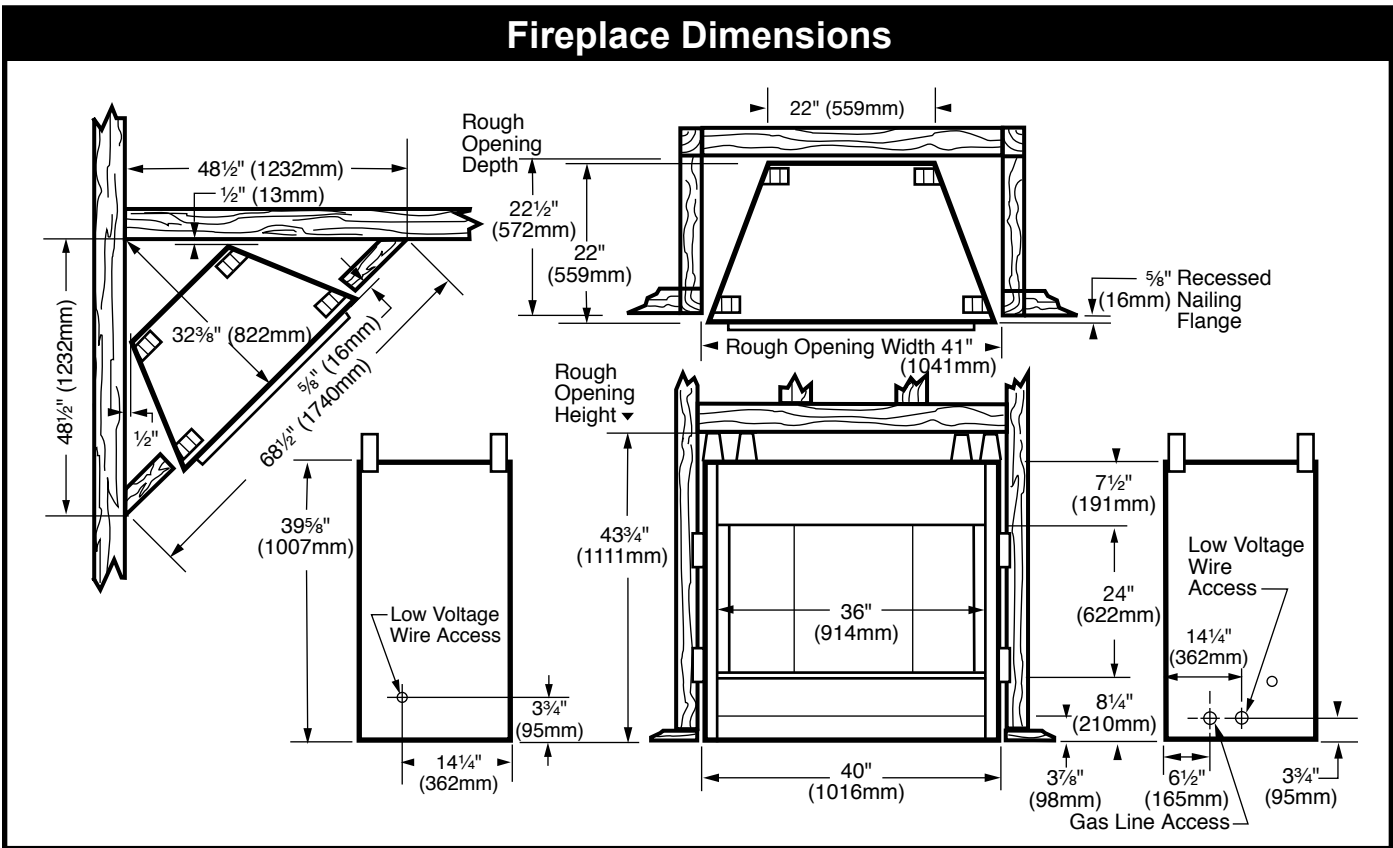

Fig. 1 ODGSR36A specification and framing dimensions.

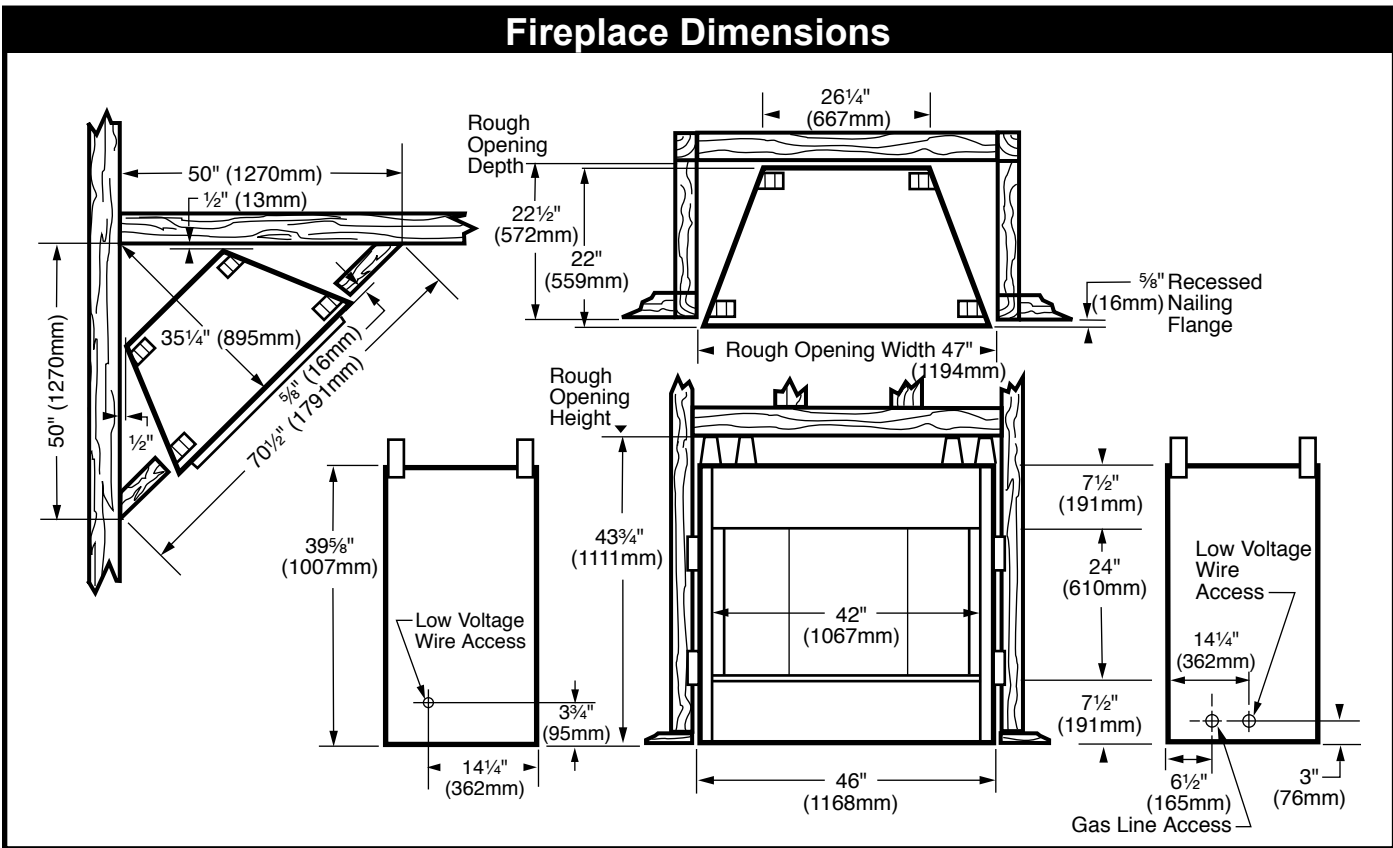

Fig. 2 ODGSR42A specification and framing dimensions.

### Moisture Resistance

This outdoor fireplace will shed moderate amounts of water, but is not waterproof. Water and condensing water vapor may enter the chase under certain conditions.

The fireplace will not perform as an exterior wall. Moisture penetration must be considered for construction that places the fireplace in structure walls or on moisture sensitive surfaces.

When installed on exterior walls: Outdoor Lifestyles recommends the fireplace chase be constructed outside the structure's weather envelope. Where the platform meets the wall, use a flashing detail similar to that required for attached decks. Chase platforms, including hearths should slope away from the structure at 1/4 in per foot. The fireplace can be shimmed level.

When installed on surfaces where water may collect or cause damage: Outdoor Lifestyles recommends a slope of 1/8 in to 1/4 in per foot towards the drain port suggested. The fireplace can be shimmed level.

Hearths should slope away from the front of the fireplace and chase at 1/8 in to 1/4 in per foot. Metal safety strips must be on top of any combustible hearth materials used for moisture management.

### Screened Porch Installation

The ODGSR may be installed safely and is design certified by CSA to be installed in a screened porch with these guidelines:

- Minimum porch area .....96 sq. feet (9 sq m)
- Minimum ceiling height ..... 92" (234 cm)
- Minimum of two (2) walls must be screened
- Minimum top of screen height, side walls .....6'6" (198 cm)
- Minimum screen area ..... 64 sq. feet (6 sq m)

### Clearance to Combustibles

#### Appliances

- Top .....0" (0 mm)
- Bottom.....0" (0 mm)
- Side.....0" (0 mm)
- Back .....0" (0 mm)
- Perpendicular Sidewall .....0" (0 mm)
- Top of unit to ceiling .....36" (914 mm)
- Front of unit to combustibles.....36" (914 mm)

### Mantels



**WARNING:** A 4" hood must be used if a mantel is to be installed.

The height that a combustible mantel is fitted above the fireplace is dependent on the depth of the mantel. This also applies to the distance between the mantel leg (if fitted) and the fireplace.

For the correct mounting height and widths refer to Figures 3a and 3b

Noncombustible mantels and legs may be installed at any height and width around the appliance.



**When using paint or lacquer to finish the mantel, such paint or lacquer must be heat resistant to prevent discoloration.**

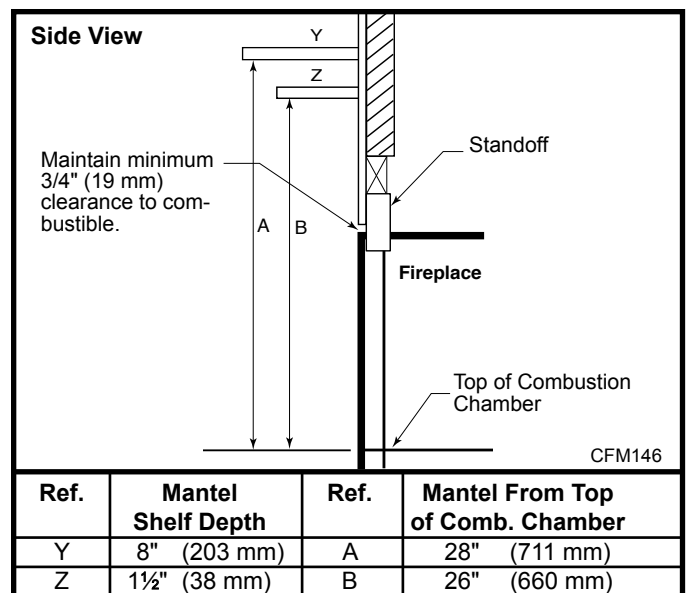

Fig. 3a Mantel clearances.

### Hearth

A hearth is not mandatory but is recommended for aesthetic purposes. We recommend a noncombustible hearth.

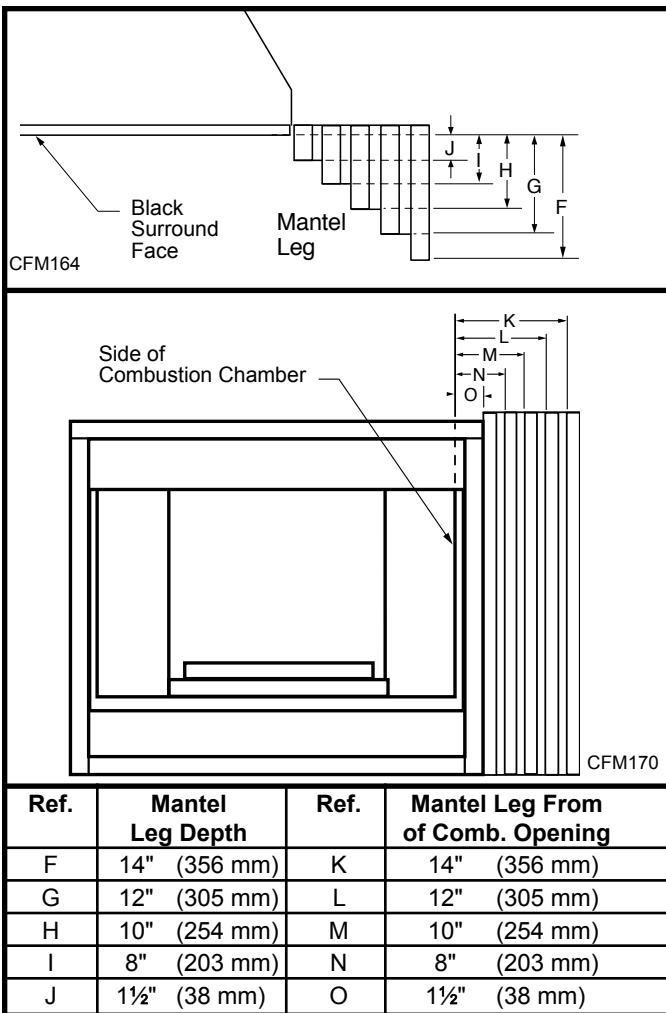

Fig. 3b Combustible mantel leg minimum installation.

### Moisture Resistance

This outdoor fireplace will shed moderate amounts of water, but is not waterproof. Water and condensing water vapor may enter the chase under certain conditions.

The fireplace will not perform as an exterior wall. Moisture penetration must be considered for construction that places the fireplace in structure walls or on moisture sensitive surfaces.

When installed on exterior walls: Outdoor Lifestyles recommends the fireplace chase be constructed outside the structure's weather envelope. Where the platform meets the wall, use a flashing detail similar to that required for attached decks. Chase platforms, including hearths should slope away from the structure at 1/4 in per foot. The fireplace can be shimmed level.

When installed on surfaces where water may collect or cause damage: Outdoor Lifestyles recommends a slope of 1/8 in to 1/4 in per foot towards the drain port suggested. The fireplace can be shimmed level.

Hearths should slope away from the front of the fireplace and chase at 1/8 in to 1/4 in per foot. Metal safety strips must be on top of any combustible hearth materials used for moisture management.

### Framing and Finishing



**Check appliance to make sure it is levelled and properly positioned.**

The appliance should only be mounted on the following surfaces:

- A flat combustible (burnable) surface.
- A raised wooden platform.
- A concrete block or other solid object placed beneath each of the four corners of the appliance.

To mount the appliance:

1. Choose unit location.
2. Four (4) nailing flanges are supplied with the fireplace (found on the fireplace hearth). To level the box and secure it firmly in place, remove the nailing flanges from the hearth and install at the sides of the fireplace as shown in Figure 4.

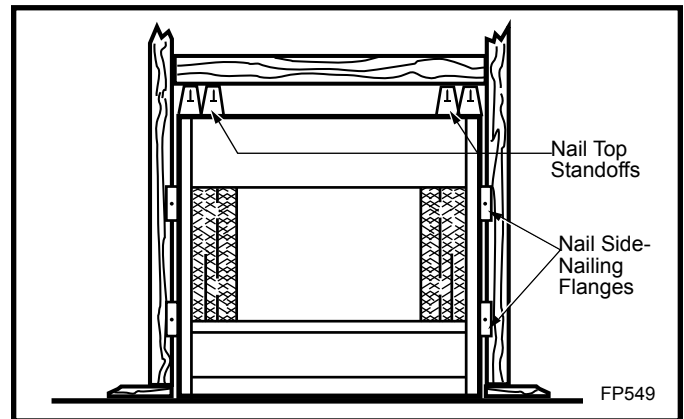

Fig. 4 Adjustable drywall strip (nailing flange).

### Finishing



**CAUTION: All joints between the finished wall and the appliance surround (top and sides) may be sealed only with non-combustible material. Only noncombustible material can be applied as facing to the appliance surround (the black painted face).**

Finish the wall with the material of your choice. Refer to Figures 3a and 3b for specific clearances when installing a combustible mantel or other combustible projection.

**Gas Specification**

Model	Fuel	Gas Control	Max. Input	Min. Input
ODGSR36ARN	Nat.	Millivolt Hi/Lo	60,000	42,600
ODGSR36ARP	Prop.	Millivolt Hi/Lo	60,000	44,000
ODGSR42ARN	Nat.	Millivolt Hi/Lo	60,000	42,600
ODGSR42ARP	Prop.	Millivolt Hi/Lo	60,000	44,000

**Gas Inlet & Manifold Pressures**

	Natural	LP
Minimum Inlet Pressure	5.5" w.c.	11.0" w.c.
Maximum Inlet Pressure	14.0" w.c.	14.0" w.c.
Manifold Pressure	3.5" w.c.	10.0" w.c.

**ODGSR36A / ODGSR42A  
Certified to**

**ANSI Z21.97  
Outdoor Decorative Gas Appliances  
CGA CR97-003  
Outdoor Gas Fireplaces**

**High Elevations**

Input ratings are shown in BTU per hour and are certified without deration from elevations up to 4,500 feet (1,370 m) above sea level.

Nuisance outages may occur at altitudes above 4,500 feet (1,370 m) if dirt, dust, lint and/or cobwebs are allowed to accumulate on burner and/or ODS pilot. Monthly inspection and cleaning is recommended for altitudes above 4,500 feet (1,370 m)

For elevations above 4,500 feet (1,370 m), installations must be in accordance with the current ANSI Z223.1/NFPA 54 and/or local codes having jurisdiction.

**Valve Access**

Valve access can be accomplished in one of two ways:

1. Remove the front panel just below the front of the hearth pan. This is accomplished by lifting on the panel. To replace the valve access panel line up the two pins with the holes in the surround bottom and push the panel over the front of the hearth pan. (Fig. 5)
2. Lift the brick with the Outdoor Lifestyles logo on it. (Fig. 6)

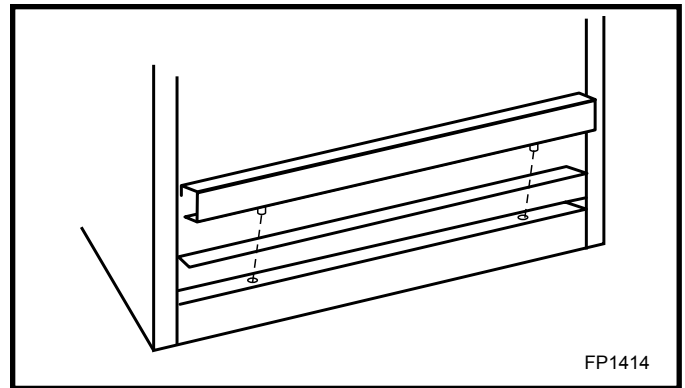

Fig. 5 Valve access.

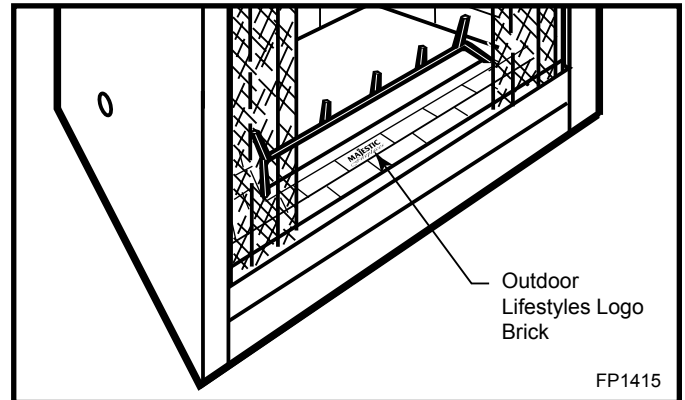

Fig. 6 Lift brick with logo on it to access valve.

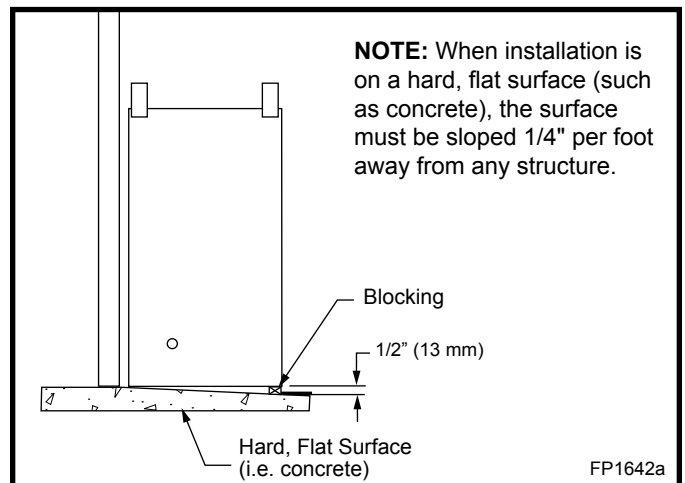

Fig. 7 Exterior chase installation.

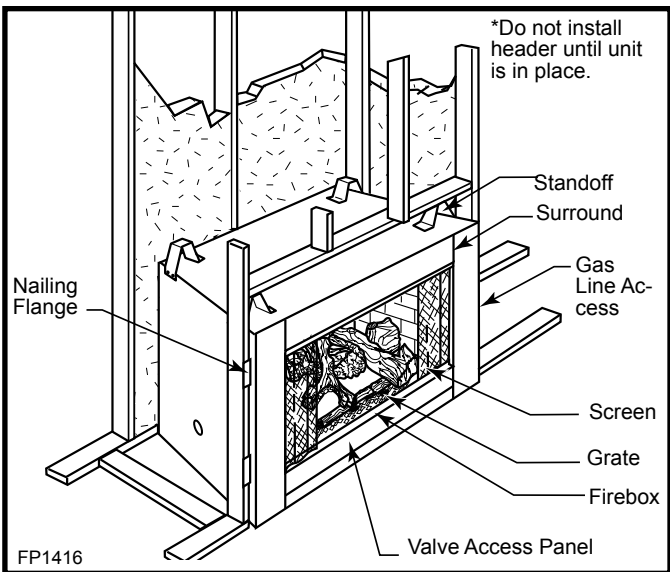

Fig. 8 Parts identification.

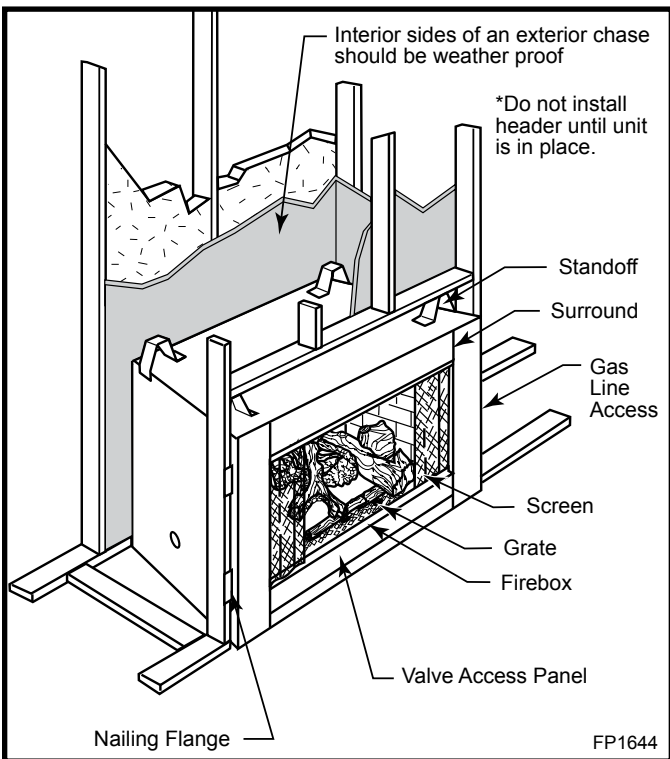

Fig. 9 Exterior chase installation.

## Gas Line Installation

This appliance must be isolated from the gas supply piping system by closing its individual manual shut off valve during any pressure equal to or less than 1/2 psig (3.45 kPa).

The appliance and its individual shutoff valve must be disconnected from the gas supply piping system during any pressure testing of that system at test pressures in excess of 1/2 psig (3.45 kPa).

If gas piping from the source to the appliance location has not been accomplished, install the required pipe. Consult local plumbing code to assure proper pipe size.

The gas pipeline can be brought in through the right side of the appliance. A knockout is provided to allow for the gas pipe installation and testing of any gas connection.

**NOTE:** The gas line connection can be made with 3/8" copper tubing approved for propane or natural gas, 1/2" rigid pipe or an approved flex connector, then reduced to 3/8" to the appliance. Because some municipalities have some additional local codes, it is always best to consult your local authority.

U.S.: Consult the current National Fuel Gas Code, ANSI Z223.1/NFPA 54.

Canada: CSA - B149.1 installation code.

Test for leaks. Use a 50/50 solution of liquid soap and water to test for leaks at gas fittings and joints. Apply water/soap solution with brush only - do not over apply. **NEVER** test with an open flame.

The gas control is equipped with a captured screw type pressure test point, therefore it is not necessary to provide a 1/8" test point up stream of the control.

When using copper or flex connector use only approved fittings. **Always provide a union** so that gas line can be easily disconnected for burner or fan servicing. See gas specification for pressure details and ratings. **NOTE:** If flex connector is used, it must be kept inside of the appliance. (Fig. 10)

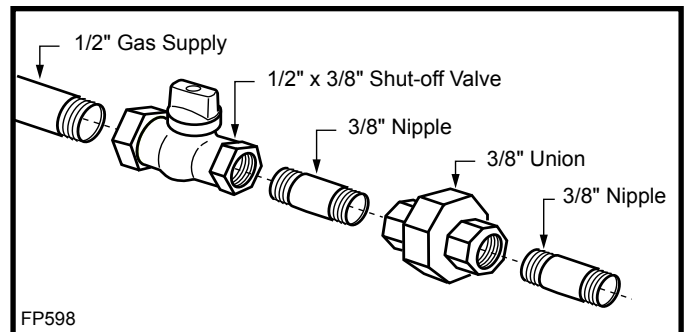

Fig. 10 Typical gas supply installation.



## Remote Wall Switch

**NOTE:** Use an approved outdoor switch.

1. Thread wire through the low voltage wire access hole located on either side of unit. Do not cut wire or insulation on metal edges. Ensure that wire is protected. Run the other end to a conveniently located wall receptacle box.
2. Attach wire to switch and install switch into receptacle box. Attach cover plate to switch.
3. Connect wiring to gas valve. Refer to Figure 11.



**CAUTION: Do not wire millivolt remote wall switch for gas appliance to a 120v power supply.**

*For lighting instructions, refer to Page 12.*



**CAUTION: After the unit cools, the burner will automatically come on.**

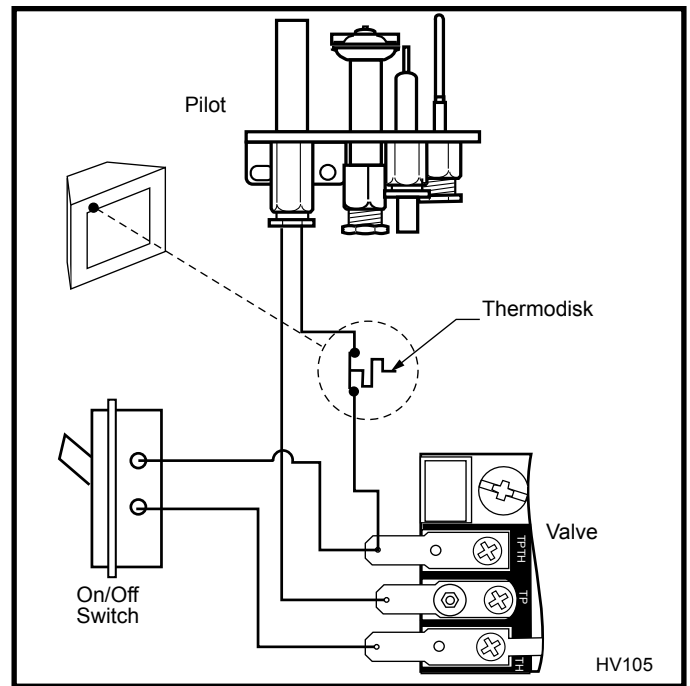

Fig. 11 Remote switch wiring.

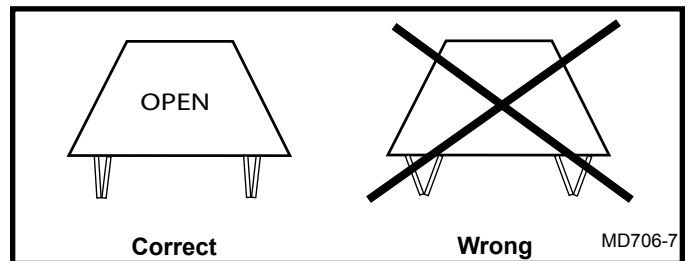

Fig. 12 Correct door position during operation.

# Operating Instructions

## Log Installation

1. Remove logs from the packaging.



**As with all plastic, these bags are not toys and should always be kept away from children and infants.**

2. Place left rear log on rear log support. Ensure that log is firmly positioned and there is no side-to-side movement. (Figs. 13 & 14)
3. Carefully place Ember Log between grate and burner. (Figs. 13 & 14)
4. Place the front of right rear log on the burner and the back of the log on the rear log support.
5. Place the top logs onto the locator notches. Ensure the logs are secure. (Fig. 13 & 14)

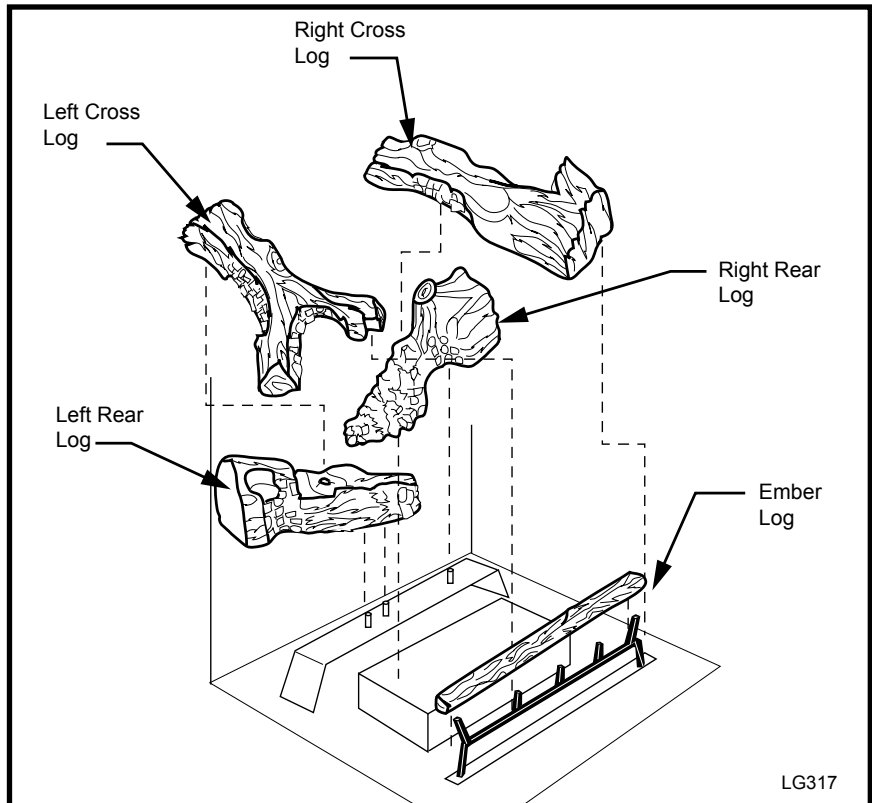

Fig. 13 ODGSR36 log placement.

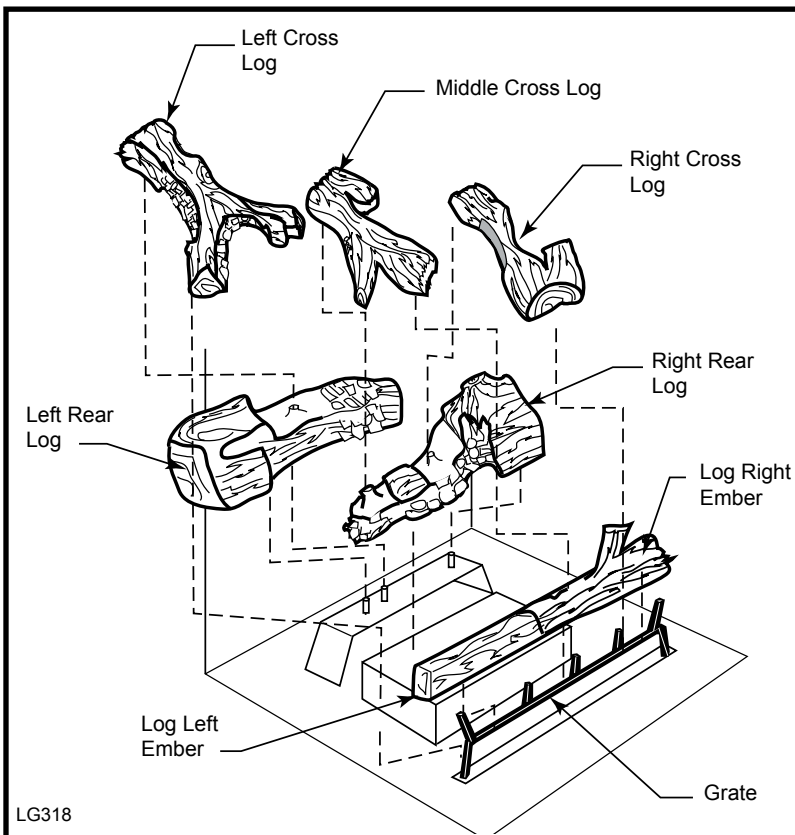

Fig. 14 ODGSR42A log placement.

## First Firing

Upon completing the gas line connection, a small amount of air will be trapped in the line. When first lighting the unit with pilot light, it will take a few minutes to purge the trapped air. Once purging is complete, the pilot and burner will light and operate as indicated in the instruction manual. Subsequent lightings of the appliance will not require purging.

When lit for the first time, the appliance will emit a slight odor for an hour or two. This is due to paint and lubricants used in the manufacturing process. After each lighting, vapor may condense and fog the glass; this moisture disappears in a few minutes of burning.

### Flame Adjustment

For units equipped with Hi/Lo valves, flame adjustment is accomplished by rotating the Hi/Lo adjustment knob located near the center of the gas control.

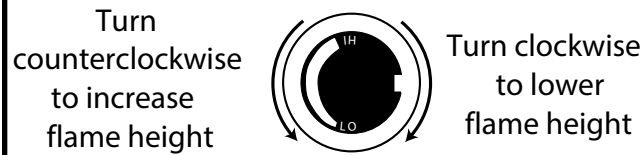

Fig. 15 Flame adjustment knob for SIT820 valve.

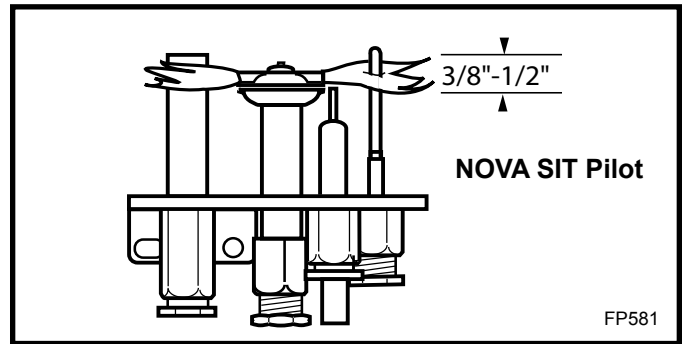

Fig. 16 Proper pilot flame height.

### Flame Characteristics

It is important to periodically perform a visual check of the pilot and the burner flames. Compare them to the illustrations below (Figs. 16, 17, 18). If any of the flames appear abnormal call a service person.

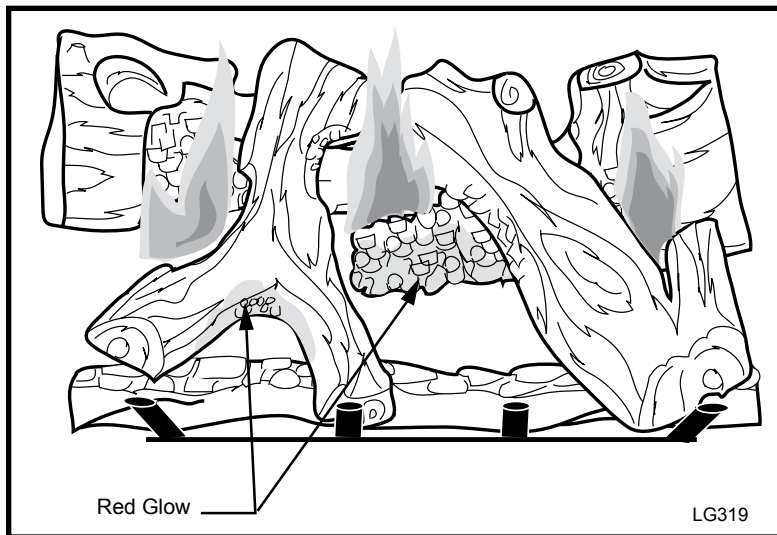

Fig. 17 ODGSR36A flame appearance.

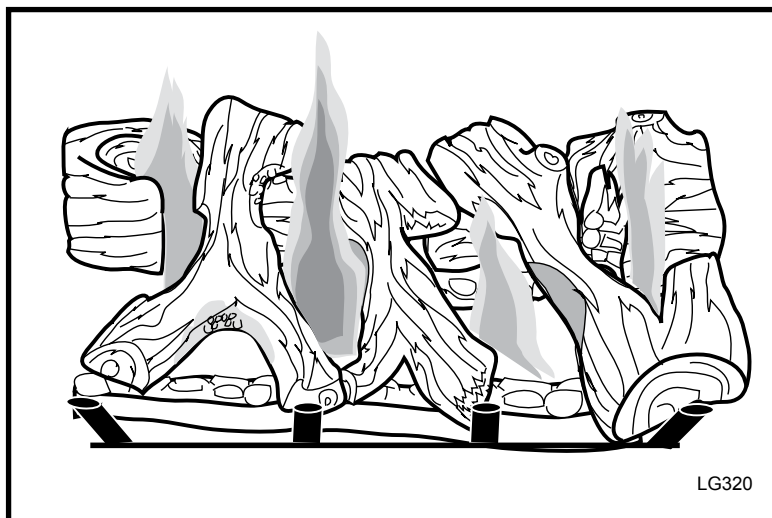

Fig. 18 ODGSR42A flame appearance.

### Optional Weather Enclosure

An optional weather enclosure is available to protect the burner when not in use.

#### Installation Instructions

1. Turn the unit OFF and allow to cool.
2. Grab the weather enclosure by the handle(s).
3. Slide the top of the weather enclosure up between the back of the surround top and the screen rail. (Fig. 19)
4. Push the bottom of the weather enclosure into the firebox just enough to clear the valve access cover and set down. (Fig. 20)

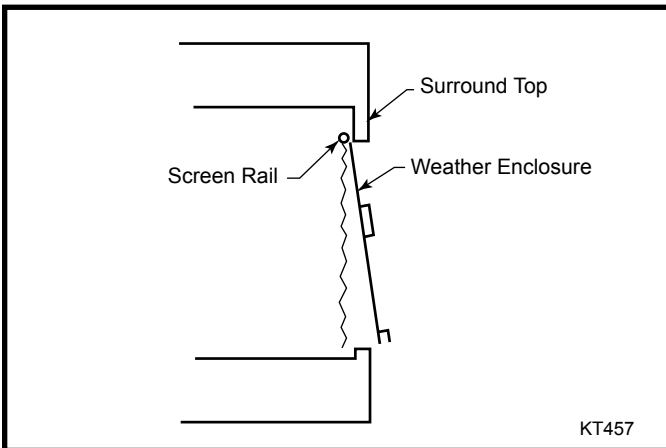

**Fig. 19** Place top of weather enclosure between surround top and screen rail.

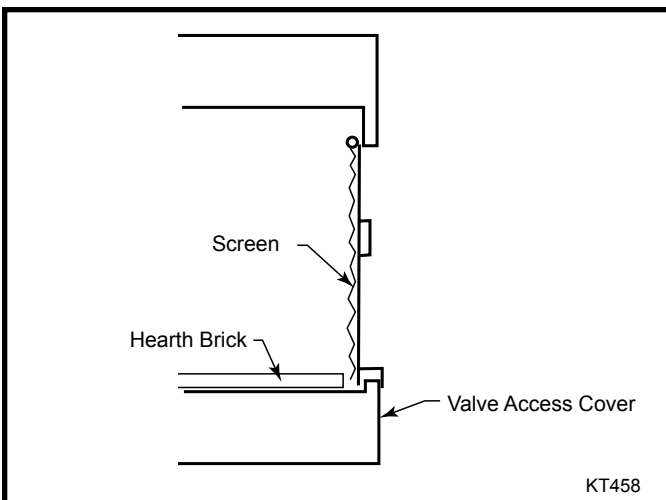

**Fig. 20** Push bottom of weather enclosure into firebox.

### Optional Stainless Steel Hood

An optional stainless steel hood is available for both the ODGSR36A and ODGSR42A.

#### Installation Instructions:

1. Turn the unit off and allow to cool.
2. Place the hood so the 2½" (67 mm) slot clears the sensor plate located under the fireplace opening on the top left side. (Fig. 21)
3. Secure the hood to the unit using the three (3) slots in the hood and the pilot holes in the unit with the stainless steel sheet metal screws provided. (Fig. 21)
4. Align the sides of the hood so the pilot holes on the right and left sides of the unit are exposed through the slots on the ends of the hood. Secure using the remaining stainless steel sheet metal screws. (Fig. 21)

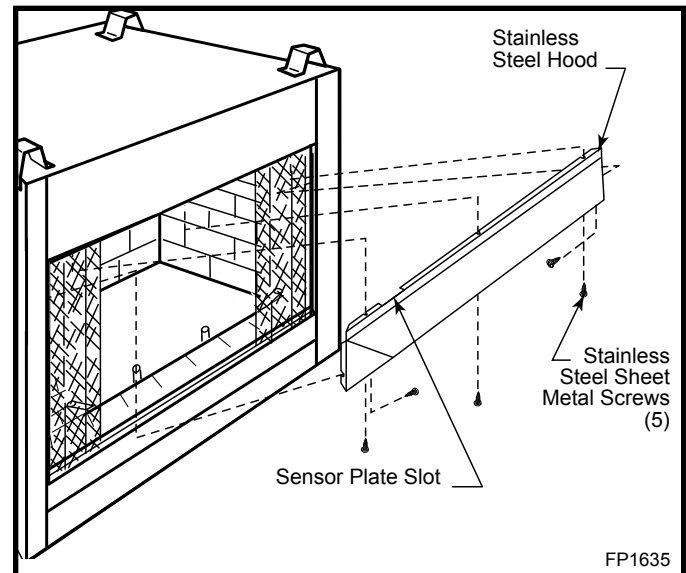

**Fig. 21** Secure stainless steel hood with five (5) sheet metal screws.

# Lighting and Operating Instructions

## FOR YOUR SAFETY READ BEFORE LIGHTING

**WARNING:** If you do not follow these instructions exactly, a fire or explosion may result causing property damage, personal injury or loss of life.

- A. This heater has a pilot which must be lit manually. When lighting the pilot follow these instructions exactly.
- B. BEFORE LIGHTING smell all around the heater area for gas. Be sure to smell next to the floor because some gas is heavier than air and will settle on the floor.
- WHAT TO DO IF YOU SMELL GAS**
- Do not try to light any fireplace
  - Do not touch any electric switch
  - Do not use any phone in your building
  - Immediately call your gas supplier from a neighbor's phone. Follow the gas supplier's instructions.
- C. If you cannot reach your gas supplier, call the Fire Department
- C. Use only your hand to push in or turn the gas control knob. Never use tools. If the knob will not push in or turn by hand, do not try to repair it, call a qualified service technician. Applying force or any attempted repair may result in a fire or explosion.
- D. Do not use this fireplace if any part has been under water. Immediately call a qualified service technician to inspect the heater and to replace any part of the control system and any gas control which has been under water.

## Lighting Instructions

- STOP!** Read the safety information above.
- Turn **OFF** all electrical power to the fireplace.
- For MN/MP/TN/TP appliances ONLY, go on to Step 4. For RN/RP appliances turn the On/Off switch to "**OFF**" position or set thermostat to lowest level.
- Open control access panel.
- Push in gas control knob slightly and turn clockwise  to "**OFF**".
- Wait five (5) minutes to clear out any gas. Then

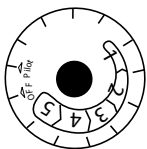

Euro SIT

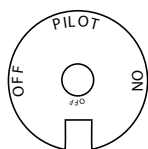

SIT NOVA



Honeywell

smell for gas, including near the floor. If you smell gas, **STOP!** Follow "B" in the safety information above. If you do not smell gas, go to the next step.

- Remove glass door before lighting pilot. (See Glass Frame Removal section).
- Visibly locate pilot by the main burner.
- Turn knob on gas control counterclockwise  to "**PILOT**".
- Push the control knob all the way in and hold.

Immediately light the pilot by repeatedly depressing the piezo spark ignitor until a flame appears. Continue to hold the control knob in for about one (1) minute after the pilot is lit. Release knob and it will pop back up. Pilot should remain lit. If it goes out, repeat steps 5 through 8.

- If knob does not pop up when released, stop and immediately call your service technician or gas

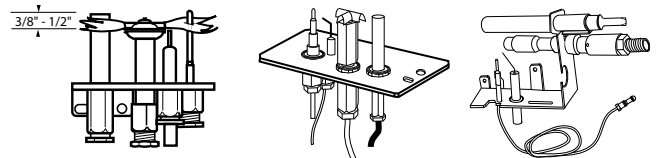

supplier.

- If after several tries, the pilot will not stay lit, turn the gas control knob to "**OFF**" and call your service technician or gas supplier.
- Replace glass door.
  - Turn gas control knob to "**ON**" position.
  - For RN/RP appliances turn the On/Off switch to "**ON**" position or set thermostat to desired setting.
  - Turn on all electrical power to the fireplace.

## To Turn Off Gas to Heater

- Turn the On/Off switch to "**OFF**" position or set the thermostat to lowest setting.
- Turn off all electric power to the fireplace if service is to be performed.
- Open control access panel.
- Push in gas control knob slightly and turn clockwise  to "**OFF**". Do not force.
- Close control access panel.

# Troubleshooting

## Nova SIT 820 Standing Pilot

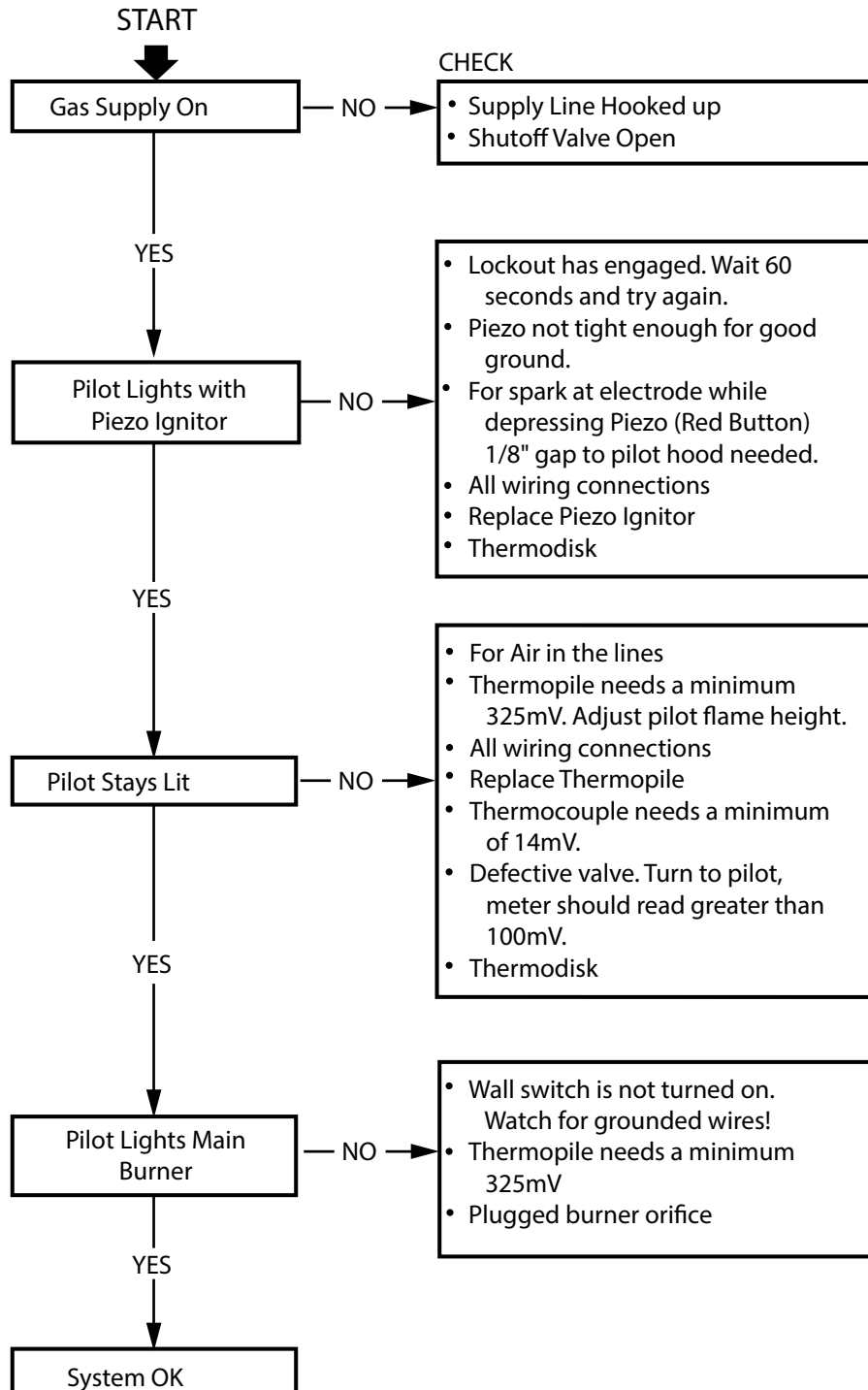

## Maintenance

### Burner and Burner Compartment

It is important to keep the burner and the burner compartment clean. At least once per year the logs should be removed and the burner compartment vacuumed and wiped out. Remove and replace the logs as per the instructions in this manual.

**Always handle the logs with care as they are fragile and may also be hot if the fireplace has been in use.**

### Cleaning

There are three methods of cleaning the polished stainless steel of your outdoor fireplace;

1. Warm, soapy water - to loosen any dirt film
2. Glass cleaner with ammonia
3. Stainless steel cleaner available at hardware stores

Regardless of which method is used, remember that anything with too much abrasive may dull the finish.

### Cleaning the Standing Pilot Control System

The burner and control system consists of:

- main burner
- gas orifice
- pilot burner
- thermopile
- combination millivolt gas valve

Most of these components may require only an occasional checkup and cleaning and some may require adjustment. If repair is necessary, it should be performed by a qualified technician.

In order to properly clean the burner and pilot assembly, turn off the gas to the unit, remove logs exposing the burner and pilot assembly. Clean all foreign materials from the top of the burner. Check to make sure that burner parts are clean. Visually inspect pilot. Brush or blow away any dust or lint accumulation. If pilot orifice is plugged, disassembly may be required to remove any foreign material from the orifice or tubing.

To obtain proper operation, it is imperative that the pilot and burner's flame characteristics are steady, not lifting or floating.

Typically, the top 3/8" or 1/2" of the thermopile should be engulfed in the pilot flame. (Fig. 16)

To adjust pilot burner, turn pilot screw marked "pilot" for proper flame size.

The air shutter is set at factory no adjustment should be necessary.

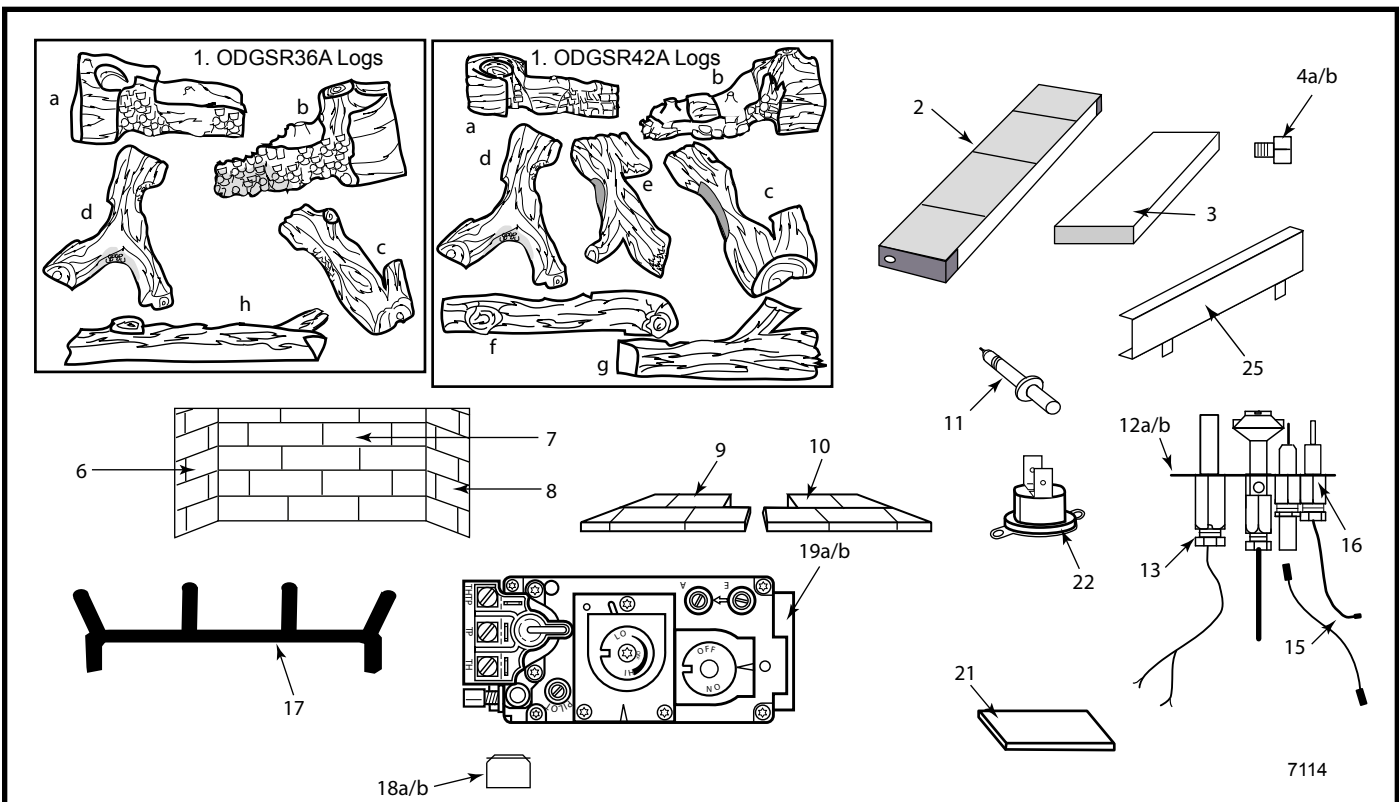

Hearth & Home Technologies reserves the right to make changes in design, materials, specifications, prices and discontinue colors and products at any time, without notice.

## ODGSR36A, ODGSR42A

Ref.	Description	ODGSR36A	ODGSR42A
1.	Logs - Complete Set	20007180K	20007200K
1a.	Log - Left Rear	20007175K	20007193
1b.	Log - Right Rear	20007176K	20007194K
1c.	Log - Right Cross	20007178K	20007197K
1d.	Log - Left Cross	20007177K	20007195K
1e.	Log - Middle Cross	--	20007196K
1f.	Log - Left Ember	--	20007198K
1g.	Log - Right Ember	--	20007199K
1h.	Front Ember Log	20007179K	--
2.	Burner Housing Assembly	20007119K	20007187K
3.	Ceramic Tile (single)	57803	57803
4a.	Burner Orifice - Natural (Manifold & Orifice)	20007106	20007106
4b.	Burner Orifice - LP (Manifold & Orifice)	20007159	20007159
6.	Side Brick - Left*	20002008K	20002008K
7.	Back Brick*	20002006K	20002019K
8.	Side Brick - Right*	20002007K	20002007K
9.	Left Hearth Brick*	20007158K	20007241K
10.	Right Hearth Brick*	20007157K	20007240K
11.	Piezo	057958	057958
12a.	Pilot Top Convertible - Natural (3 Way Assembly)	10002264	10002264
12b.	Pilot Top Convertible - LP (3 Way assembly)	10002265	10002265
13.	Thermopile 18"	26D0566	26D0566



## ODGSR36A, ODGSR42A (continued)

Ref.	Description	ODGSR36A	ODGSR42A
14.	Pilot Tubing	10001296	10001296
15.	Cable Ignitor 24"	7522432	7522432
16.	Thermocouple 24"	24D0808	24D0808
17.	Grate	20006819K	20006819K
18a.	Pilot Orifice - Natural	37D0022	37D0022
18b.	Pilot Orifice - LP	37D0023	37D0023
19a.	Valve NOVA - Natural	37D0117	37D0117
19b.	Valve NOVA - LP	37D0118	37D0118
20a.	Air Shutter - Natural	20009120	20000129
21.	Hearth Brick Cover	20007183K	20007183K
22.	Thermodisk	20007568	20007568
23.	Conversion Kit LP to Natural	20008549	20008550
24.	Conversion Kit Natural to LP	20008548	20008551
25.	Valve Access Panel Assy	20009119K	20008296K
26.	Screen Assy	20306388K	20306387K
27.	Gasket, Fiber Frax	20003793	--
28.	Spring door track	20006267K	20006267K

Contact Hearth & Home Technologies for questions concerning prices and policies covering replacement parts. Parts may be ordered through your Outdoor Lifestyles Fireplaces distributor or dealer.

You will need the following information when ordering replacement parts:

1. The appliance model number.
2. The serial number.
3. A description of the part.

Should you need additional information beyond what your dealer can furnish, contact:

Hearth & Home Technologies  
 7571 215th Street West, Lakeville, MN 50044  
[www.hearthnhome.com](http://www.hearthnhome.com)

Model and serial numbers are listed on the rating plate (located on right side of combustion chamber).

Record your model and serial numbers here for future reference:

Model # \_\_\_\_\_

Serial # \_\_\_\_\_

## Accessories

The following accessories are available from your local Outdoor Lifestyles Fireplaces distributor. Each accessory comes with a separate installation instruction for mounting to the particular firebox. Be sure to read each instruction thoroughly before installing.

Accessory	Description	Model Number
4" Stainless Steel Hood	For heater up to 40,000 BTU's and mantels 8" high by 12" wide	UV36SH4 UV42SH4
Weather Enclosure	Designed to protect the burner when unit is not in use	ODG36WE ODG42WE

**CAUTION:** This firebox is a highly engineered system, and must be operated only with Hearth & Home Technologies approved components. If you use an unapproved component to make any modifications, you may create a possible fire hazard and will void the warranty. In addition, such action may void the coverage provided by the owner's insurance.

# LIMITED LIFETIME WARRANTY

## PRODUCT COVERED BY THIS WARRANTY

All Vermont Castings gas stoves, gas inserts, and gas fireplaces, and all Monessen and Outdoor Lifestyles brand gas fireplaces equipped with an Insta-Flame Ceramic Burner, or standard steel tube burner.

### BASIC WARRANTY

Outdoor Lifestyles (hereinafter referred to collectively as the Company) warrants that your new Vermont Castings, Monessen or Outdoor Lifestyles Gas Fireplace/Stove is free from manufacturing and material defects for a period of one year from the date of purchase, subject to the following conditions and limitations.

### EXTENDED LIFETIME WARRANTY

The heat exchanger, where applicable, and combustion chamber of every Vermont Castings, Monessen or Outdoor Lifestyles gas product is warranted for life against through wall perforation. All appliances equipped with an Insta-Flame Ceramic Burner have limited lifetime coverage on the ceramic burner plaque. Warrantees are made to the original owner subject to proof of purchase and the conditions and limitations listed on this Warranty Document

### COMPONENT WARRANTY

**CAST IRON:** All external and internal cast iron parts are warranted for a period of three years.

**Note:** On porcelain enamel finished external parts and accessories The Company offers no Warranty on chipping of enamel surfaces. Inspect all product prior to accepting it for any damage to the enamel.

The salt air environment of coastal areas or a high humidity environment can be corrosive to the porcelain enamel finish. These conditions can cause rusting of the cast iron beneath the porcelain enamel finish, which will cause the finish to flake off.

Dye lot variations with replacement parts and/or accessories can occur and are not covered by warranty.

**BRASS PLATED PARTS AND ACCESSORIES:** Brass parts should be cleaned with Lemon oil only. Brass cleaners cannot be used. Mortar mix and masonry cleaners may corrode the brass finish. The Company will not be responsible for, nor will it warrant any brass parts which are damaged by external chemicals or down draft conditions.

**GAS VALVES:** Gas valves are covered for a period of one year

**ELECTRONIC AND MECHANICAL COMPONENTS:** Electronic and mechanical components of the burner assembly are covered for one year. All steel tube burners are warranted for one year.

**ACCESSORIES:** Unless otherwise noted, all components and Outdoor Lifestyles company supplied accessories are covered for a period of one year.

### CONDITIONS AND LIMITATIONS

- This Vermont Castings or Outdoor Lifestyles product must be installed or serviced by a qualified installer, preferably NFI or WETT (Canada) certified, as prescribed by the local jurisdiction. It must be installed and operated at all times in accordance with the Installation and Operating instructions furnished with the product. Any alteration, willful abuse, accident, or misuse of the product shall nullify this warranty.
- This warranty is non-transferable, and is made to the original owner, provided that the purchase was made through an authorized supplier of the Company.
- The customer must pay for any Authorized Dealer in-home travel fees or service charges for in-home repair work. It is the dealers option whether the repair work will be done in the customer's home or in the dealer's shop.
- If upon inspection, the damage is found to be the fault of the manufacturer, repairs will be authorized at no charge to the customer parts and/or labor.
- Any part and/or component replaced under the provisions of this warranty is covered for six months or the remainder of the original warranty, whichever is longest.
- This warranty is limited to the repair of or replacement of part(s) found

to be defective in material or workmanship, provided that such part(s) have been subjected to normal conditions of use and service, after said defect is confirmed by the Company's inspection.

- The company may, at its discretion, fully discharge all obligations with respect to this warranty by refunding the wholesale price of the defective part(s)
- Any installation, labor, construction, transportation, or other related costs/expenses arising from defective part(s), repair, replacement, or otherwise of same, will not be covered by this warranty, nor shall the Company assume responsibility for same. Further, the Company will not be responsible for any incidental, indirect, or consequential damages except as provided by law.
- SOME STATES DO NOT ALLOW FOR THE EXCLUSION OR LIMITATIONS OF INCIDENTAL AND CONSEQUENTIAL DAMAGES OR LIMITATIONS ON HOW LONG AN IMPLIED WARRANTY LASTS, SO THE ABOVE LIMITATIONS MAY NOT APPLY TO YOUR CIRCUMSTANCES. THIS WARRANTY GIVES YOU SPECIFIC RIGHTS AND YOU MAY HAVE OTHER RIGHTS WHICH VARY FROM STATE TO STATE.
- All other warranties-expressed or implied- with respect to the product, its components and accessories, or any obligations/liabilities on the part of the Company are hereby expressly excluded.
- The Company neither assumes, nor authorizes any third party to assume on its behalf, any other liabilities with respect to the sale of this Vermont Castings, Monessen or Outdoor Lifestyles product
- The warranties as outlined within this document do not apply to chimney components or other non-Outdoor Lifestyles accessories used in conjunction with the installation of this product.
- Damage to the unit while in transit is not covered by this warranty but is subject to claim against the common carrier. Contact the dealer from whom you purchased your fireplace/stove (do not operate the appliance as this might negate the ability to process the claim with the carrier).
- The Company will not be responsible for:
  - a) Down drafts or spillage caused by environmental conditions such as near-by trees, buildings, roof tops, hills, or mountains.
  - b) Inadequate ventilation or negative air pressure caused by mechanical systems such as furnaces, fans, clothes dryers, etc.
- This warranty is void if:
  - a) The fireplace has been operated in atmospheres contaminated by chlorine, fluorine, or other damaging chemicals.
  - b) The fireplace has been subjected to prolonged periods of dampness or condensation
  - c) Any damages to the fireplace, combustion chamber, heat exchanger or other components due to water, or weather damage, which is the result of but not limited to, improper chimney/venting installation.
  - d) Any alteration, willful abuse, accident, or misuse of the product has occurred.

### IF WARRANTY SERVICE IS NEEDED...

- 1) Contact your supplier. Make sure you have your warranty, your sales receipt, and the model/serial number of your Outdoor Lifestyles product.
- 2) DO NOT ATTEMPT TO DO ANY SERVICE WORK YOURSELF.



Hearth & Home Technologies  
7571 215th Street West, Lakeville, MN 50044  
[www.hearthnhome.com](http://www.hearthnhome.com)