

HARMAN®

BUILT TO A STANDARD, NOT A PRICE

XXXV

PELLET STOVE



BUILT TO A STANDARD NOT A PRICE

Sealed hopper holds
up to 65 lbs

Distinctive finishing colors
include: classic black,
porcelain majolica brown,
porcelain black,
porcelain dark blue and
porcelain frost

Large viewing area

Large, concealed ash pan



Variable speed blower

Intricate cast detailing

Flame-reactive
mirrored glass

Above & Cover: XXV shown with optional porcelain black finish

The XXV pellet stove is a tribute to years of Harman success and an uncompromising commitment to quality. It's also the quietest Harman pellet stove ever.

The XXV utilizes PelletPro and ESP technology to burn any grade of pellet with precision control. Up to 50,000 BTUs of high-efficiency, even heat provide extended performance with minimal maintenance. Intricate oak leaf styling, traditional cast iron craftsmanship and 5 bold finish options create a distinctive look in any space.





XXV shown with optional porcelain majolica brown finish



XXV shown with optional porcelain dark blue finish

FEATURES & OPTIONS

The XXV was engineered with distinctive features offering convenience, safety and style. Superior craftsmanship and advanced operation combine in this powerful pellet stove.

Features

- 49,300 BTUs¹—heats 900 to 2,300 square feet²
- Up to 65lb hopper capacity
- 78% efficiency³
- Automatic ignition and temperature control
- Quiet, variable speed blower
- Exclusive door air wash system
- Large ash pan
- Flame-reactive mirrored glass

Options

- Porcelain majolica brown, porcelain black, porcelain dark blue or porcelain frost finishes
- Top vent adapter kit
- Outside air kit
- Direct Vent wall pass-through



Black (Standard) Porcelain Black Porcelain Dark Blue Porcelain Majolica Brown Porcelain Frost

PelletPro™ System

The patented PelletPro system makes it possible to burn any grade of pellet fuel with maximum heat and efficiency. A bottom-up feeding system burns each pellet completely and allows for 24-hour heating.

To learn more about the PelletPro System, visit HarmanStoves.com.

ESP Temperature Control

Harman pellet stoves utilize an advanced Exhaust Sensing Probe (ESP) system to deliver precision heating control. ESP constantly monitors and adjusts heat output to maintain set room temperatures within 1 degree.

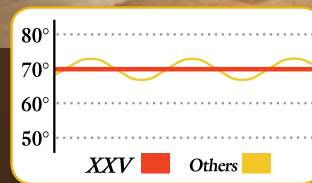

The XXV's **temperature control** helps maintain a consistent room temperature.

To learn more about ESP Temperature Control, visit HarmanStoves.com.



Optional top vent adapter

SPECIFICATIONS

XXV
PELLET STOVE

BTU/Hour Input ¹	Feed Rate	Heating Capacity ²	Efficiency ³	Emissions	Blower Size	Fuel	Hopper Capacity	Weight	Width	Height	Depth	Venting Size
14,200 - 49,300	1.8lbs/hr min 5.4lbs/hr max	900 - 2,300 sq ft	78%	1.8 g/hr	175 CFM	Wood pellets	65 lbs	375 lbs	29-7/16"	31-1/8"	28-9/16"	3"

Dimensions



Front View

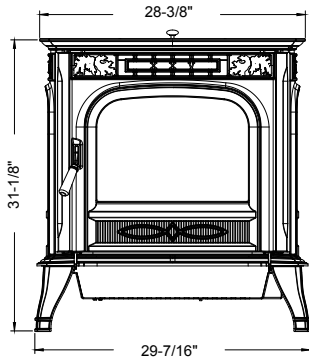

Side View

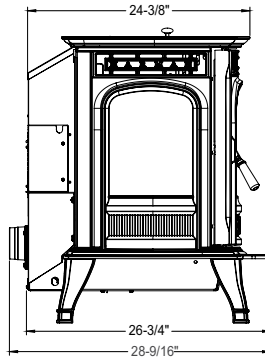

Back View

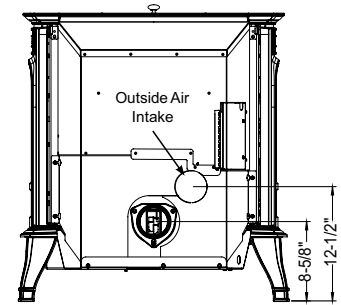

Floor Protection

Floor Protection		US	Canada
J	Sides	6"	200mm
K	Front	6"	450mm
L	Rear	0"	200mm

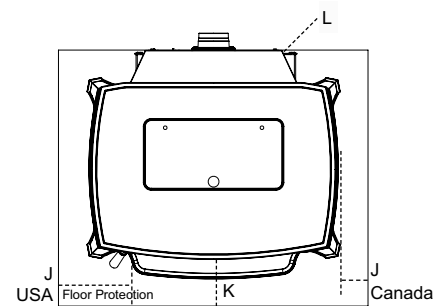

MINIMUM HEARTH PROTECTION

Standard	40-7/16"W x 27-9/16"D
Corner	40"W x 40"D ⁴

Clearances to Combustibles

Standard Installation

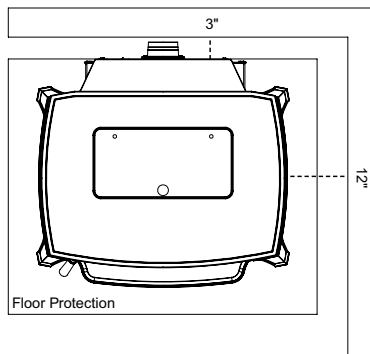

Corner Installation

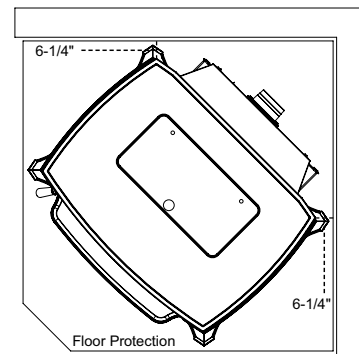

YOUR HARMAN DEALER IS:

HARMAN[®]
BUILT TO A STANDARD, NOT A PRICE

PHONE: 800-664-3119
WWW.HARMANSTOVES.COM

facebook.com/HarmanStoves
twitter.com/HarmanStoves
youtube.com/HarmanStoves

HAR-1108U-1015

LIMITED LIFETIME WARRANTY⁵

The strongest in the industry, Harman provides a limited lifetime warranty on most important aspects: firebox and heat exchanger.

¹EPA tested input. ²See your local authorized Harman dealer for help in determining the product that best suits your heating needs based on climate and home efficiency. ³Weighted Average LHV (low heating value) Efficiency ⁴Minimum size corner hearthpad will not touch the wall. Wall to stove clearances are priority. ⁵For full warranty details, visit www.harmanstoves.com.

Actual product appearance, including flame, may differ from image. Tested by OMNI-Test Laboratories - ASTM E 1509-04, ULLC/DAD-C1482-M1990, ULLC-S627-00. Product specifications and pricing subject to change without notice. The images and descriptions in this brochure are provided to assist you in product selection only. Fuel density and pellet shape may affect hopper capacity. BTU's may vary depending on type of fuel used. Refer to installation manual for complete clearance requirements and specifications.

Fireplace, stove and insert surfaces get extremely HOT and can cause severe burns if touched. Keep a safe distance away. To learn more visit www.harmanstoves.com/fireplacesafety