

# Absolute43

Pellet Stove



**HARMAN**<sup>®</sup>

BUILT TO A STANDARD, NOT A PRICE

**T** rue luxury is Absolute. It's undisputed and confident. In the Absolute43, performance and engineering excellence are infused into every design and detail. From its compact frame and powerful heat production, to its whisper-quiet operation and groundbreaking new Harman EASY Touch Control, this is true luxury.



Left: Absolute43 in matte black paint  
 Right: Absolute43 in porcelain majolica brown finish shown with Harman Protect Cast Iron Hearth Pad Cover: Absolute43 in porcelain majolica brown finish

## EASY Touch Control

The Harman EASY Touch Control is the most advanced control system ever created—and makes it easy to heat your home:

- **Easy:** Operate your stove quickly and easily with intuitive touchscreen controls
- **Accurate:** Maintain desired heat levels all day, every day and save fuel using the scheduling feature
- **Smart:** Monitor performance automatically and receive notifications when maintenance is needed
- **Yearly Savings:** Save money on heating bills with industry-leading technology and features, and high efficiency





## Features

- Smart operation with EASY Touch Controls
- Near silence in Whisper mode<sup>1</sup>
- Welcome warmth created by multidirectional air flow technology
- Save money with built-in programmable thermostat
- View fuel levels easily with tinted hopper lid and LED light
- Stunning fire created by flame enhancer
- Less loading with 52lb hopper capacity
- Elegant flame-reactive mirrored glass
- Installation made easy with direct vent

## Options

- Matte black or porcelain majolica brown finish
- Harman Protect Cast Iron Hearth Pad (matte black only)
- Wireless room sensor
- Direct vent wall pass-through
- Outside air kit
- Top vent adapter



Filling the large, 52-pound hopper is easy. Observe fuel levels through the tinted hopper lid, or let the Harman EASY Touch Control automatically remind you when fuel is low.



A large and concealed ash pan provides easy access and reduces maintenance time.



Optional wireless room sensor complements the EASY Touch Control and gives you the most precise temperature where you want to feel the heat.

## Key Technologies

More than 35 years of engineering excellence and heating performance, distilled into these exclusive technologies.



**EASY Touch Control** Harman's easy-to-use, industry-leading touch control provides one screen operation and gives access to optional menus such as scheduling, diagnostics, cleaning prompts and fuel gauges which give you complete control of your stove.



**PelletPro™ Technology** This patented system makes it possible to burn any grade of pellet fuel with maximum heat and efficiency. A bottom-up feed system burns each pellet completely and allows for 24-hour heating.



**ESP Temperature Control** Harman pellet stoves utilize an advanced Exhaust Sensing Probe (ESP) system to deliver precise heating control. ESP constantly monitors and adjusts heat output to maintain set room temperatures within one degree.

## Specifications



BTU/Hr Input<sup>2</sup>..... 15,800-45,300  
 Efficiency<sup>3</sup>..... 78%  
 Emissions ..... 1.8 g/hr  
 Heating Capacity<sup>4</sup>..... 2,400 sq ft  
 Hopper Capacity..... 52 lb  
 Fuel Type..... Pellet  
 Feed Rate..... 1.7-5 lb/hr  
 Venting Size..... 3-inch

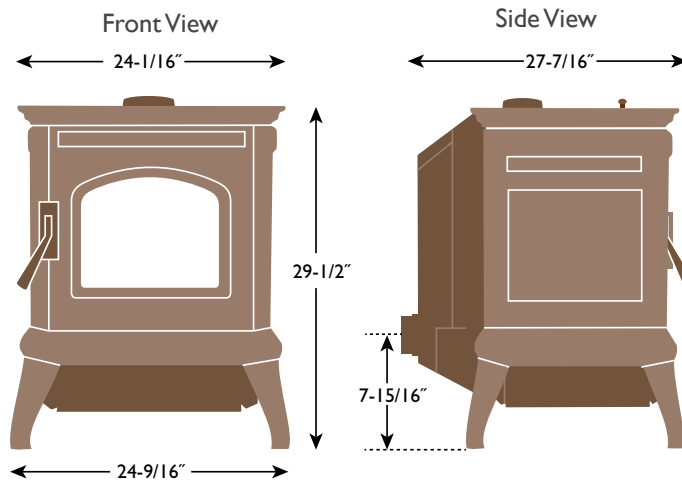

## Clearance to Combustibles

MINIMUM HEARTH PROTECTION	
Standard	25-7/8"W x 28"D
Corner	36"W x 36"D <sup>5</sup>

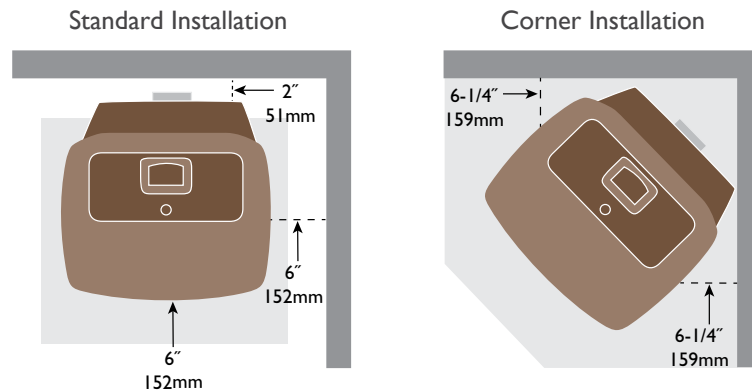

Available From:

**HARMAN**<sup>®</sup>  
 BUILT TO A STANDARD, NOT A PRICE

WWW.HARMANSTOVES.COM

facebook.com/HarmanStoves  
 twitter.com/HarmanStoves  
 youtube.com/HarmanStoves

HAR-1113U-0616

## Limited Lifetime Warranty<sup>6</sup>

The strongest in the industry, Harman provides a limited lifetime warranty on most important aspects: firebox and heat exchanger.

1 Based on third party accredited lab testing with units set on high and Absolute43 in Whisper mode. 2 EPA tested input. 3 Weighted Average LHV (Low Heating Value) Efficiency. 4 See your local authorized Harman dealer for help in determining the product that best suits your heating needs based on climate and home efficiency. 5 Minimal hearth pad will not touch walls on corner installation. 6 For full warranty details, visit www.harmanstoves.com Actual product appearance, including flame, may differ from image. Tested by OMNI-Test Laboratories: ASTM E 1509-2012 and ULC-S627-00, Mobile Home Approved. Product specifications and pricing subject to change without notice. The images and descriptions in this brochure are provided to assist you in product selection only. Fuel density and pellet shape may affect hopper capacity. BTU/Hour Input may vary depending on type of fuel used. Refer to installation manual for complete clearance requirements and specifications. Fireplace, stove and insert surfaces get extremely HOT and can cause severe burns if touched. Keep a safe distance away. To learn more visit www.harmanstoves.com/fireplacesafety